

# TYPICAL APPLICATIONS OF PAVEMENT MARKINGS AND MARKERS

F.A.P. RTE.	SECTION	COUNTY	TOTAL SHEETS	SHEET NO.
811	(2250)I	CHAMPAIGN	22	21

CONTRACT NO. 70437

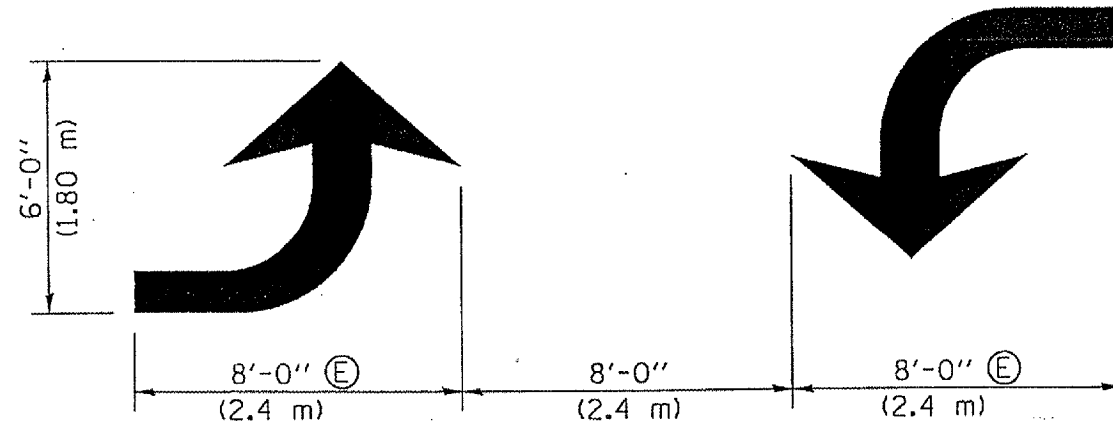

TYPICAL DOUBLE  
TURN ARROWS (WHITE)

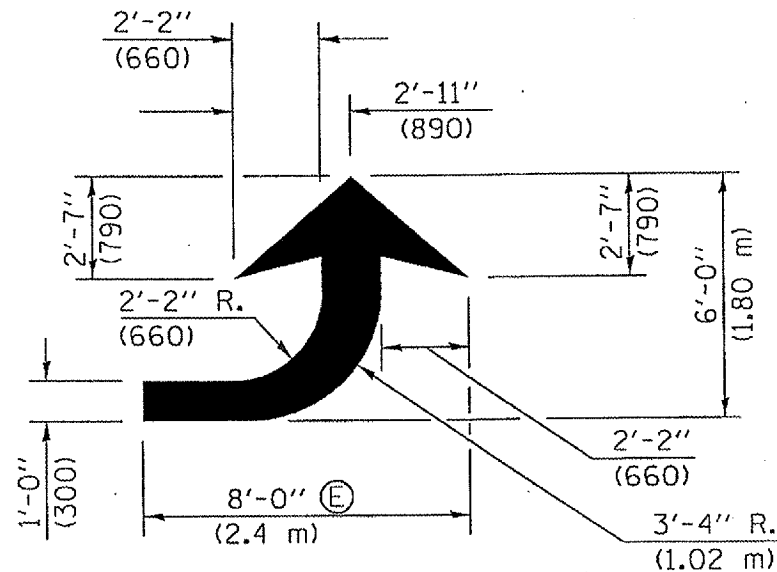

LEFT ARROW

REVERSE FOR RIGHT ARROW  
AREA = 15.6 SQ. FT. (1.47 m<sup>2</sup>)  
(WHITE)

SPECIAL NOTES:

- Ⓑ TURN ARROW PAIRS SHALL BE PLACED AT 250' (75 m) INTERVALS AND SHALL BE EVENLY SPACED BETWEEN BOTH ENDS OF THE BIDIRECTIONAL LEFT TURN LANE.
- Ⓒ THE SOLID YELLOW PAVEMENT MARKINGS [2] SHOULD GENERALLY START OR END NEAR THE RADIUS POINT OF EACH STREET RETURN EXCEPT WHERE ONE OR BOTH ENDS WOULD INCLUDE STOP BARS.
- Ⓓ THE SKIP-DASH PAVEMENT MARKINGS [1] OR [7] SHOULD BE CENTERED BETWEEN BOTH ENDS OF EACH CITY BLOCK AND SHALL BE PLACED SO THEY LINE UP ACROSS FROM EACH OTHER. SEE EXAMPLE ON SHEET 4 OF 6.
- Ⓔ TURN ARROW SIZE DEPENDS ON THE LOCATION.  
RURAL LOCATION - LARGE ARROW SIZE  
URBAN LOCATION - SMALL ARROW SIZE

SHEET 5 OF 6

	NAME	DATE	REVISIONS	
DESIGNED	J.M.H.	5/85	NAME	DATE
CHECKED	FMS	6/88	GEOMETRICS/K.A.G.	07/02
CADD NO.	F-5.25	6/85	K.A.G.	08/04

ALL DIMENSIONS ARE IN INCHES (MILLIMETERS)  
UNLESS OTHERWISE SHOWN.