

F.A.P. RTE.	SECTION	COUNTY	TOTAL SHEETS	SHEET NO.
71	(3R)RS-5	SANGAMON	25	7
STA.		TO STA.		
FED. ROAD DIST. NO.		ILLINOIS FED. AID PROJECT		
CONTRACT NO. 72614				

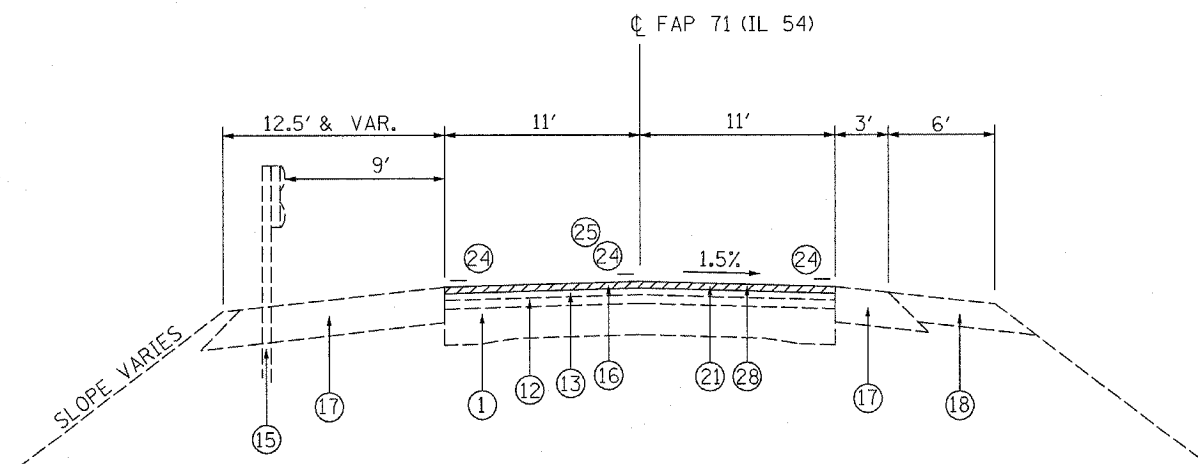

LT. STA. 173+71.15 TO STA. 179+97.59      RT. STA. 174+03.95 TO STA. 178+06.84  
 RT. STA. 178+06.84 TO STA. 179+97.59

BRIDGE OMISSION  
 STA. 179+97.59 TO STA. 189+09.27

LT. STA. 189+09.27 TO STA. 190+84.07      LT. STA. 190+84.07 TO STA. 194+54.48  
 RT. STA. 189+09.27 TO STA. 190+33.22      RT. STA. 190+33.22 TO STA. 194+54.48

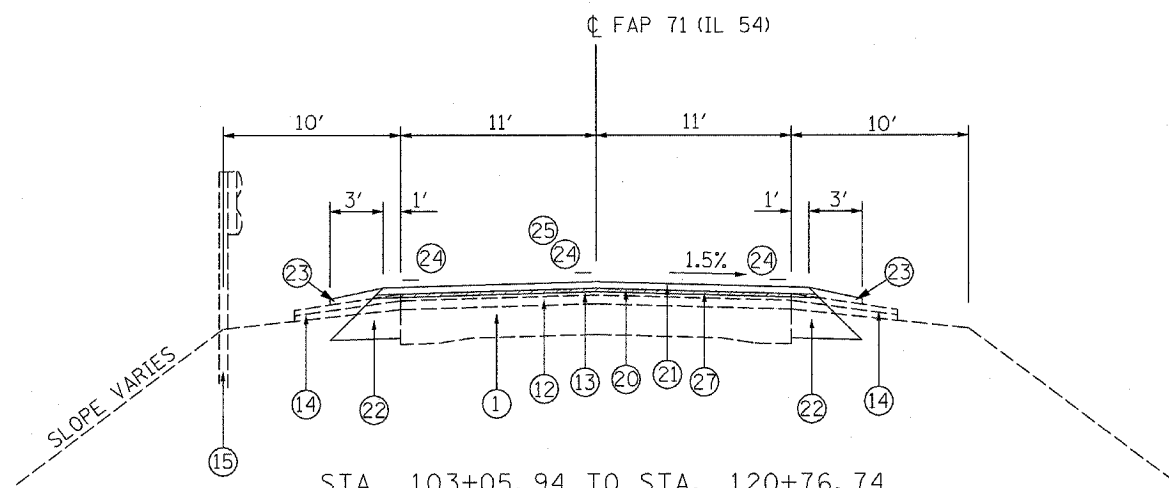

STA. 103+05.94 TO STA. 120+76.74  
 STA. 132+82.60 TO STA. 166+98.70  
 STA. 194+54.48 TO STA. 217+62.38  
 STA. 227+45.79 TO STA. 265+05.65  
 EQUATION STA. 265+05.65 BK. TO STA. 40+88.70 AHD.  
 STA. 40+88.70 TO STA. 55+00

- 1. ORIGINAL 22' P.C. CONCRETE PAVEMENT (1940)
- 2. EXISTING P.C. CONCRETE BASE COURSE 9" (1962)
- 3. EXISTING BITUMINOUS SURFACE AND BINDER COURSE 3" (1962)
- 4. EXISTING AGGREGATE SHOULDER 8" (1962)
- 5. EXISTING SUB-BASE GRANULAR MATERIAL TYPE A 6" (1962)
- 6. EXISTING P.C. CONCRETE BASE COURSE WIDENING 9" (1962)
- 7. EXISTING CONCRETE CURB AND GUTTER (1962)
- 8. EXISTING P.C. CONCRETE MEDIAN SURFACE 2 1/2" OR P.C. CONCRETE MEDIAN TYPE B MODIFIED (SOLID) (1962)
- 9. EXISTING P.C. CONCRETE BASE 8" (1975)
- 10. EXISTING STABILIZED SUB-BASE 4" (1975)
- 11. EXISTING GRAVEL SHOULDER TYPE B (1962)
- 12. EXISTING BITUMINOUS CONCRETE SURFACE 2" (1977)
- 13. EXISTING BITUMINOUS CONCRETE SURFACE 1 1/2" (1991)
- 14. EXISTING AGGREGATE SHOULDERS (PLACED AT VARIOUS TIMES - NO DEFINED THICKNESS)
- 15. EXISTING GUARDRAIL
- 16. EXISTING BITUMINOUS CONCRETE SURFACE 1 1/2" (1996)
- 17. EXISTING BITUMINOUS CONCRETE SHOULDER 8" (1996)
- 18. EXISTING AGGREGATE SHOULDER, TY. B 6" (1996)
- 20. PROPOSED LEVELING BINDER (MACHINE METHOD), SUPERPAVE N 50 (3/4")
- 21. PROPOSED BITUMINOUS CONCRETE SURFACE COURSE, SUPERPAVE, MIX "D" N50 (1 1/2")
- 22. PROPOSED BITUMINOUS CONCRETE BASE COURSE WIDENING, SUPERPAVE 10 INCH
- 23. PROPOSED AGGREGATE SHOULDERS, TYPE B
- 24. PROPOSED PAVEMENT MARKING
- 25. PROPOSED RAISED REFLECTIVE PAVEMENT MARKERS
- 27. PROPOSED BITUMINOUS SURFACE REMOVAL (VARIABLE DEPTH) - NOMINAL DEPTH AT 1/2"
- 28. PROPOSED BITUMINOUS SURFACE REMOVAL 1 1/2"

REVISIONS		ILLINOIS DEPARTMENT OF TRANSPORTATION
NAME	DATE	
		F.A.P. RTE. 71 (IL 54) TYPICAL SECTIONS
DATE		DRAWN BY
		CHECKED BY

c:\projects\ed52901\jdd\12-20-04\typicalsection.dgn  
 2/10/2005  
 \*REF01