

**PAVED AREA CABLE IN CONDUIT TRENCH DETAIL**  
 N.T.S.

NOTE: CONDUIT SHALL BE INSTALLED AT AN ELEVATION THAT WILL NOT CONFLICT WITH THE OTHER UTILITIES SUCH AS SANITARY SEWER, STORM SEWER, WATERMAIN, UNDERDRAIN, AND ETC.

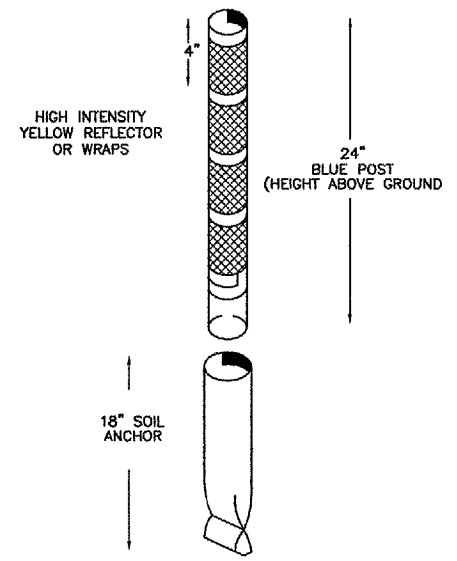

**TAXIWAY RETROREFLECTIVE MARKER DETAIL**  
 NOT TO SCALE

NOTE: RETROREFLECTIVE MARKER SHALL BE SAFE-HIT OR APPROVED EQUAL.

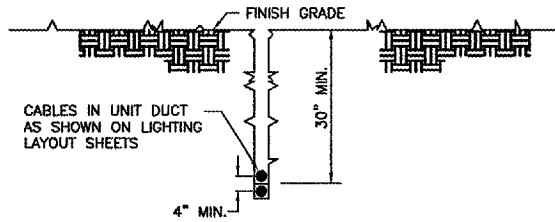

**CABLE IN UNIT DUCT - PLOWED**  
 NOT TO SCALE

NOTE: CONTRACTOR SHALL HAVE THE OPTION TO TRENCH OR PLOW UNIT DUCT. NO ADDITIONAL PAYMENT SHALL BE MADE FOR TRENCHING.

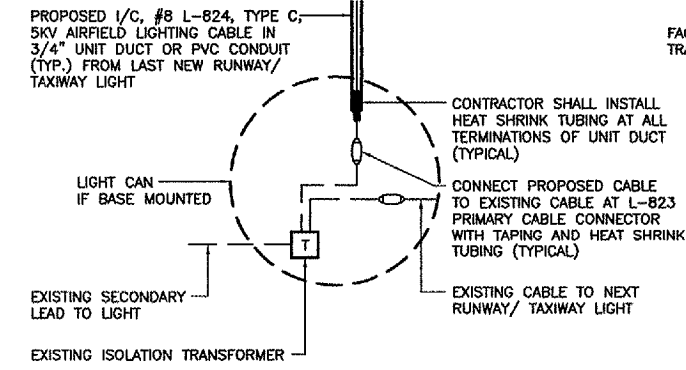

**RUNWAY/TAXIWAY LIGHTING CIRCUIT CONNECTION DETAIL**  
 NOT TO SCALE

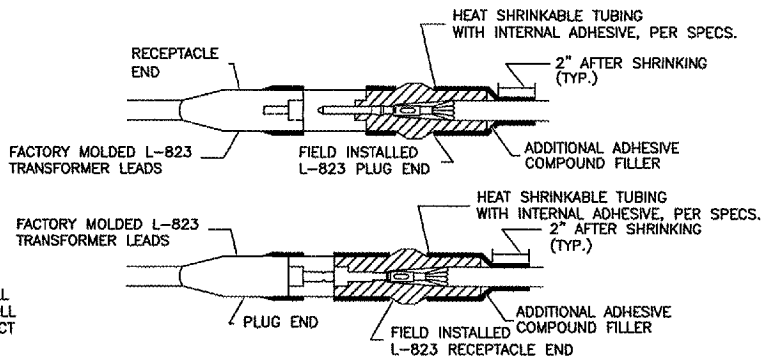

**TYPE C AND D - CABLE SPLICE**

FOR SPLICES AT RUNWAY/TAXIWAY LIGHTS AND SIGNS  
 NOT TO SCALE

**CABLE SPLICE NOTES**

1. INSIDE DIAMETER OF CONNECTOR SHALL PROPERLY MATCH THE OUTSIDE DIAMETER OF CABLE.
2. WRAP WITH AT LEAST ONE LAYER OF RUBBER OR SYNTHETIC RUBBER TAPE AND ONE LAYER OF PLASTIC TAPE, ONE-HALF LAPPED, EXTENDING AT LEAST 1-1/2 INCHES ON EACH SIDE OF JOINT.
3. THE COST OF FURNISHING AND INSTALLING ALL SPLICE MATERIALS SHALL BE INCIDENTAL TO THE ASSOCIATED CABLE ITEMS.
4. THE CONTRACTOR SHALL HAVE A MINIMUM OF TWO (2) TYPE A SPLICE KITS ON THE JOB SITE AT ALL TIMES FOR EMERGENCY REPAIRS.

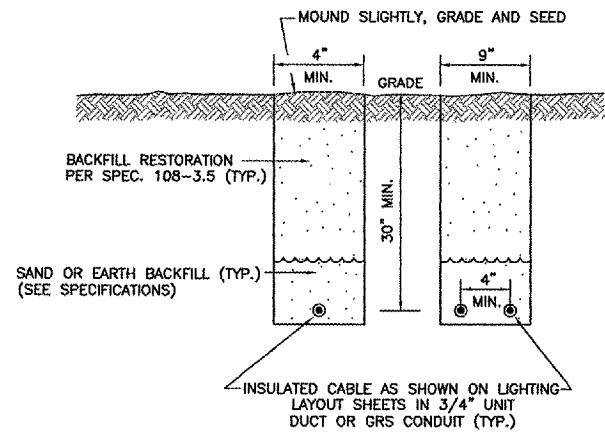

**TURF AREA CABLE TRENCH DETAIL**  
 NOT TO SCALE

**NOTES**

1. TRENCHES WITH MORE THAN 2 CABLES SHALL BE INCREASED 4" IN WIDTH FOR EACH ADDITIONAL CABLE. IF SPECIFIED ON PLANS, TWO PARALLEL TRENCHES MAY BE CONSTRUCTED.
2. DEPTH OF TRENCHES SHALL BE AS SHOWN UNLESS OTHERWISE SPECIFIED ON THE PLANS.
3. SAND BACKFILL SHALL BE USED IF THE EXISTING SOIL DOES NOT MEET THE BACKFILL REQUIREMENTS.
4. ALL DISTURBED SURFACES SHALL BE RESTORED TO THEIR ORIGINAL CONDITION. COST IS INCIDENTAL.

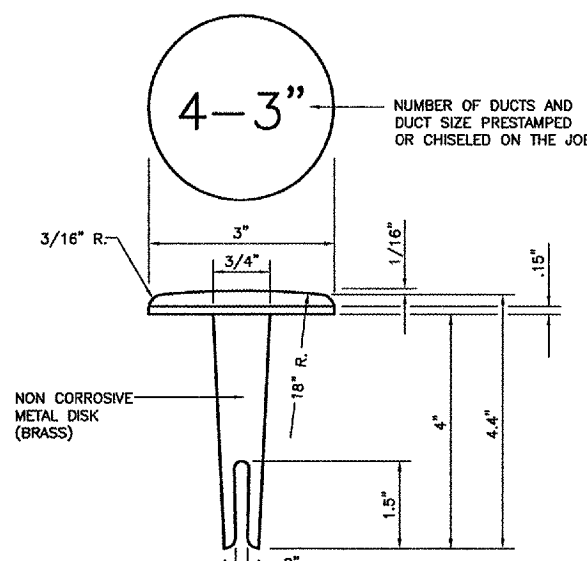

**DUCT MARKER DETAIL**  
 NOT TO SCALE

DUCT MARKERS SHALL BE DRILLED AND GROUTED SO THEY ARE RECESSED FROM THE SURFACE OF THE PAVEMENTS.

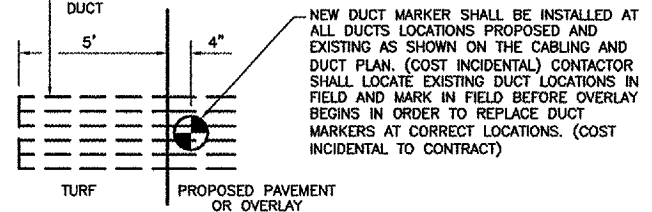

NEW DUCT MARKER SHALL BE INSTALLED AT ALL DUCTS LOCATIONS PROPOSED AND EXISTING AS SHOWN ON THE CABLING AND DUCT PLAN. (COST INCIDENTAL) CONTRACTOR SHALL LOCATE EXISTING DUCT LOCATIONS IN FIELD AND MARK IN FIELD BEFORE OVERLAY BEGINS IN ORDER TO REPLACE DUCT MARKERS AT CORRECT LOCATIONS. (COST INCIDENTAL TO CONTRACT)

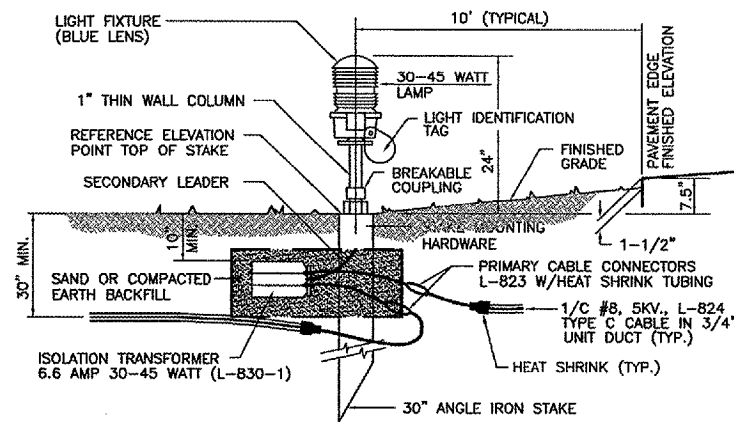

**PROPOSED/ADJUSTED/RELOCATED STAKE MOUNTED MEDIUM INTENSITY TAXIWAY LIGHT**  
 NOT TO SCALE

**GENERAL NOTES:**

1. THE VEHICULAR BARRIERS/BOLLARDS WILL NOT BE MEASURED SEPARATELY FOR PAYMENT BUT SHALL BE CONSIDERED INCIDENTAL TO THE CONCRETE UTILITY PAD.
2. LOCATION OF UNDERGROUND ELECTRICAL ITEMS SHALL BE COORDINATED WITH VEHICULAR BARRIERS/BOLLARDS TO AVOID ANY CONFLICTS
3. NUMBER OF BARRIERS/BOLLARDS TO BE INSTALLED SHALL BE AS REQUIRED BY THE UTILITY COMPANY

REVISIONS		
NUMBER	BY	DATE

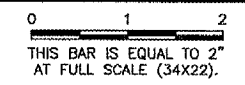

**LANSING MUNICIPAL AIRPORT**  
**LANSING, ILLINOIS**  
**NORTH QUADRANT SITEWORK - PHASE 1**  
**AND TAXIWAY G2 EXTENSION**  
**ELECTRICAL DETAILS - SHEET 1**

© Copyright CMT, Inc.

**CMT**  
 CHAMFORD, MURPHY & TILLY, INC.  
 CONSULTING ENGINEERS  
 License No. 184-000613

Lansing Municipal Airport

DESIGN BY:	DKP
DRAWN BY:	JRO
CHECKED BY:	ARM
APPROVED BY:	
DATE:	03/04/05
JOB No:	03297-02
IL PROJECT:	IGQ-3329
A.I.P. PROJECT:	3-17-0121-B21
SHEET	22 OF 50 SHEETS