

EXISTING LEGEND

- (A) EXISTING PORTLAND CEMENT CONCRETE PAVEMENT
- (B) EXISTING HMA SUB-BASE
- (C) EXISTING AGGREGATE SUBGRADE
- (D) EXISTING CONCRETE SHOULDER
- (E) EXISTING CURB & GUTTER
- (F) EXISTING PIPE UNDERDRAIN
- (G) EXISTING SUB-BASE GRANULAR MATERIAL
- (H) EXISTING AGGREGATE SHOULDER
- (I) EXISTING BITUMINOUS CONCRETE OVERLAY, 3" AND 10"
- (J) EXISTING HMA OVERLAY, 4"±
- (K) EXISTING HMA PAVEMENT
- (L) EXISTING HMA SHOULDER
- (M) EXISTING BITUMINOUS CONCRETE SHOULDER
- (N) EXISTING GROUND OR BASE COURSE, VARIES
- (O) EXISTING TEMPORARY CONCRETE BARRIER

PROPOSED LEGEND

- (1) HOT-MIX ASPHALT SURFACE COURSE. MIX "D", N70, 1.75"
- (2) HOT-MIX ASPHALT BINDER COURSE, IL-19.0, N70, 2.25"
- (3) HOT-MIX ASPHALT SHOULDERS, 10" (IN 3 LIFTS)
- (4) PORTLAND CEMENT CONCRETE PAVEMENT 10" (JOINTED)
- (5) STRIP REFLECTIVE CRACK CONTROL TREATMENT
- (6) STABILIZED SUB-BASE - HOT MIX ASPHALT, 4 1/2"
- (7) AGGREGATE SUBGRADE 12"
- (8) SUB-BASE GRANULAR MATERIAL, TYPE B
- (9) BITUMINOUS MATERIALS (PRIME COAT)
- (10) AGGREGATE (PRIME COAT)
- (11) AGGREGATE SHOULDERS, TYPE B 8"
- (12) AGGREGATE SHOULDERS, TYPE B 10"
- (13) PORTLAND CEMENT CONCRETE SHOULDERS 10"
- (14) PORTLAND CEMENT CONCRETE BASE COURSE 10"
- (15) PIPE UNDERDRAINS 6", 36" NOMINAL DEPTH
- (16) CONCRETE BARRIER, VARIABLE CROSS-SECTION, VARIABLE HEIGHT (SEE PLANS FOR EXACT TYPE)
- (17) CONCRETE BARRIER BASE (SEE PLANS FOR EXACT TYPE)
- (18) COMBINATION CONCRETE CURB AND GUTTER, TYPE B-6.24
- (19) CONCRETE MEDIAN SURFACE, 4" (INCLUDES 4" COARSE AGGREGATE FILL)
- (20) DRILL AND GROUT NO. 8 TIE BARS AT 24" CTS.
- (21) LONGITUDINAL CONSTRUCTION JOINT NO. 8 x 24" TIE BARS AT 24" CTS.
- (22) LONGITUDINAL SAWED JOINT NO. 6 x 36" TIE BARS AT 18" CTS.
- (23) NO. 8 TIE BARS AT 24" CTS.
- (24) TOPSOIL FURNISH AND PLACE, 4"
- (25) PROPOSED EMBANKMENT
- (26) PROPOSED DRAINAGE DITCH

UNSUITABLE EXCAVATION

TOPSOIL SHALL BE PLACED ONLY IN LOCATIONS OF PERMANENT SEEDING. SEE LANDSCAPE PLAN FOR LIMITS/LOCATIONS.

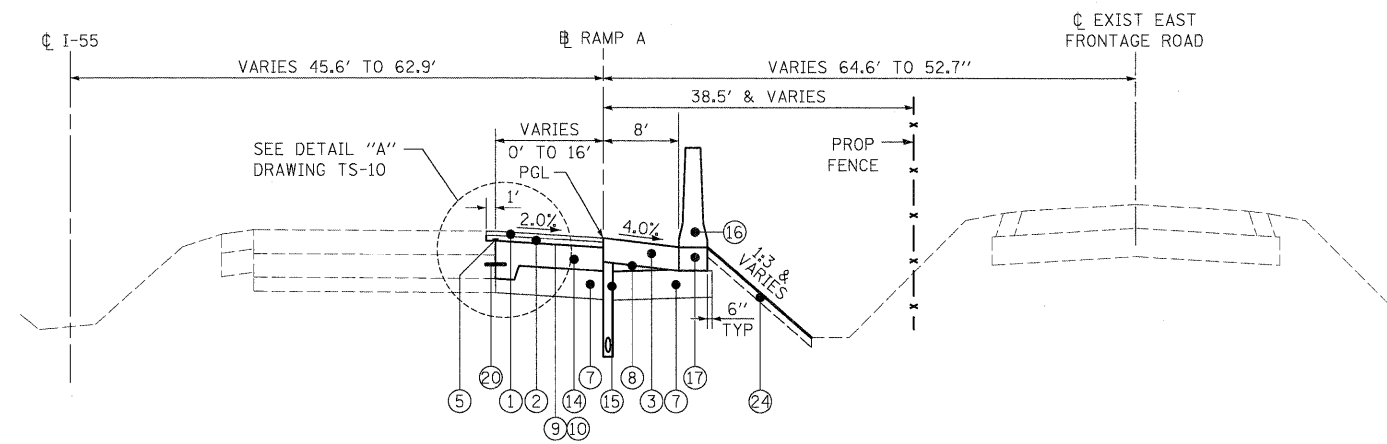

PROPOSED TYPICAL SECTION - RAMP A
 STA. 1011+51.29 TO 1011+75.45 (C I-55)
 STA. 7000+0.00 TO STA. 7003+36.11

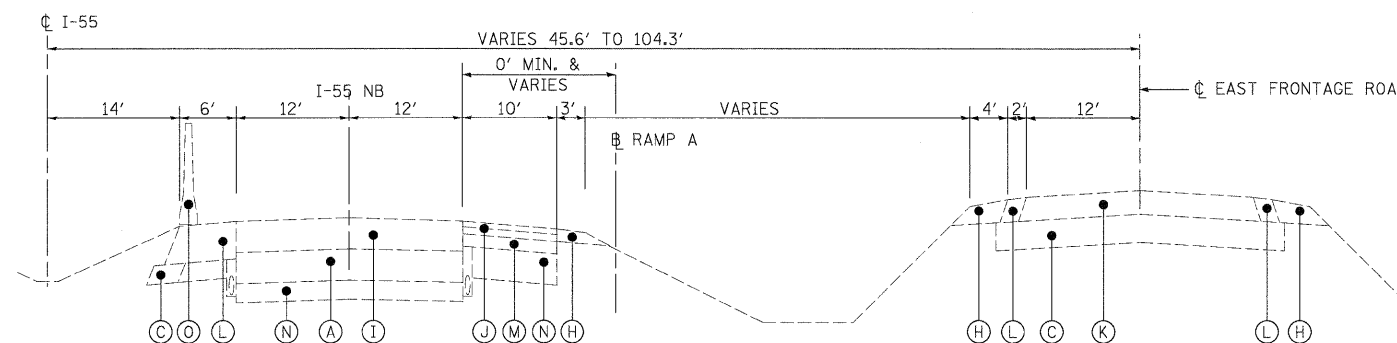

EXISTING TYPICAL SECTION - NB I-55

EXISTING TYPICAL SECTION - EAST FRONTAGE RD

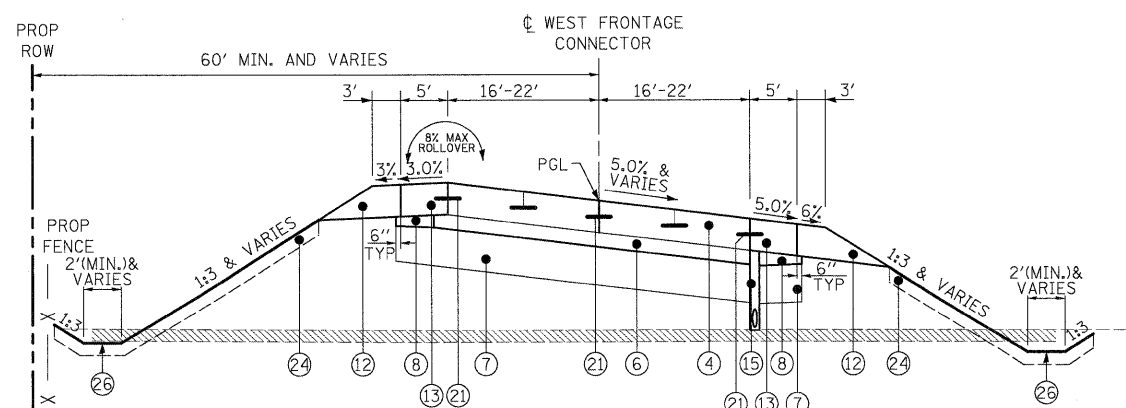

PROPOSED TYPICAL SECTION - WEST FRONTAGE CONNECTOR ON CURVE
 STA. 6078+94.04 TO STA. 6067+87.04 (S.E. TRANSITION)
 STA. 6067+87.04 TO STA. 6071+83.52 (FULL S.E. 5.00%)
 STA. 6071+83.52 TO STA. 6073+75.52 (S.E. TRANSITION)

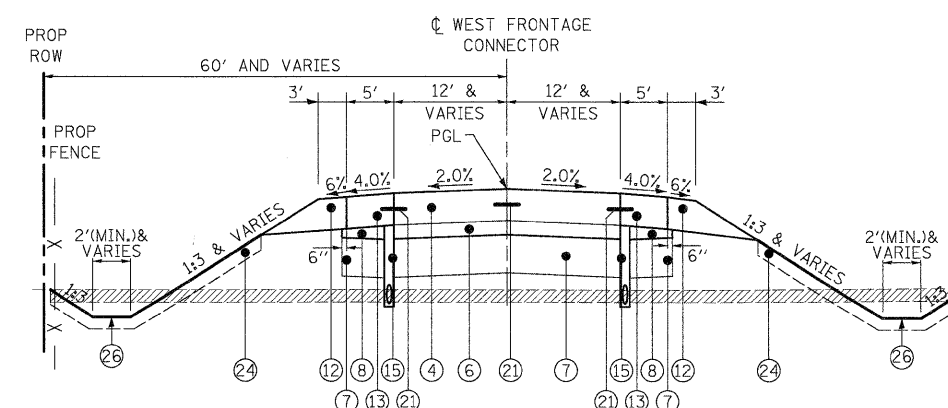

PROPOSED TYPICAL SECTION - WEST FRONTAGE CONNECTOR ON TANGENT
 STA. 6077+54.15 TO STA. 6078+94.04
 STA. 6089+94.32 TO STA. 6090+40.84

NOTE:
 STA. 6087+17.32 TO STA. 6089+94.32
 BRIDGE & APPROACH SLAB
 SEE BRIDGE PLANS FOR DETAILS

FILE NAME =	USER NAME = TKLuegel	DESIGNED - MJT	REVISED -
D:\B2\F12-SHT-TYPICAL05.dgn		DRAWN - MJT	REVISED -
		CHECKED - DLT	REVISED -
		DATE - 2/4/11	REVISED -

F.A.I. RTE.	SECTION	COUNTY	TOTAL SHEETS	SHEET NO.
55	99-2HB-2B-1	WILL	756	20
FED. ROAD DIST. NO. 1 ILLINOIS FED. AID PROJECT			CONTRACT NO. 60F12	