

NOTES:

1. SEE DRAWING GE-1 FOR ELECTRICAL SYMBOL LIST AND ABBREVIATIONS.
2. SEE DRAWING S-3 FOR HIGH MAST LIGHT TOWER FOUNDATION TABLE.

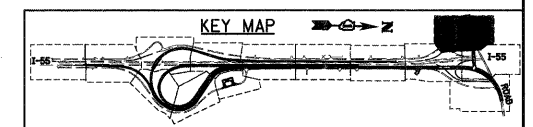
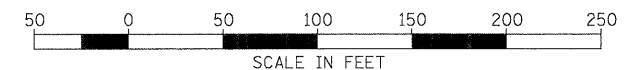
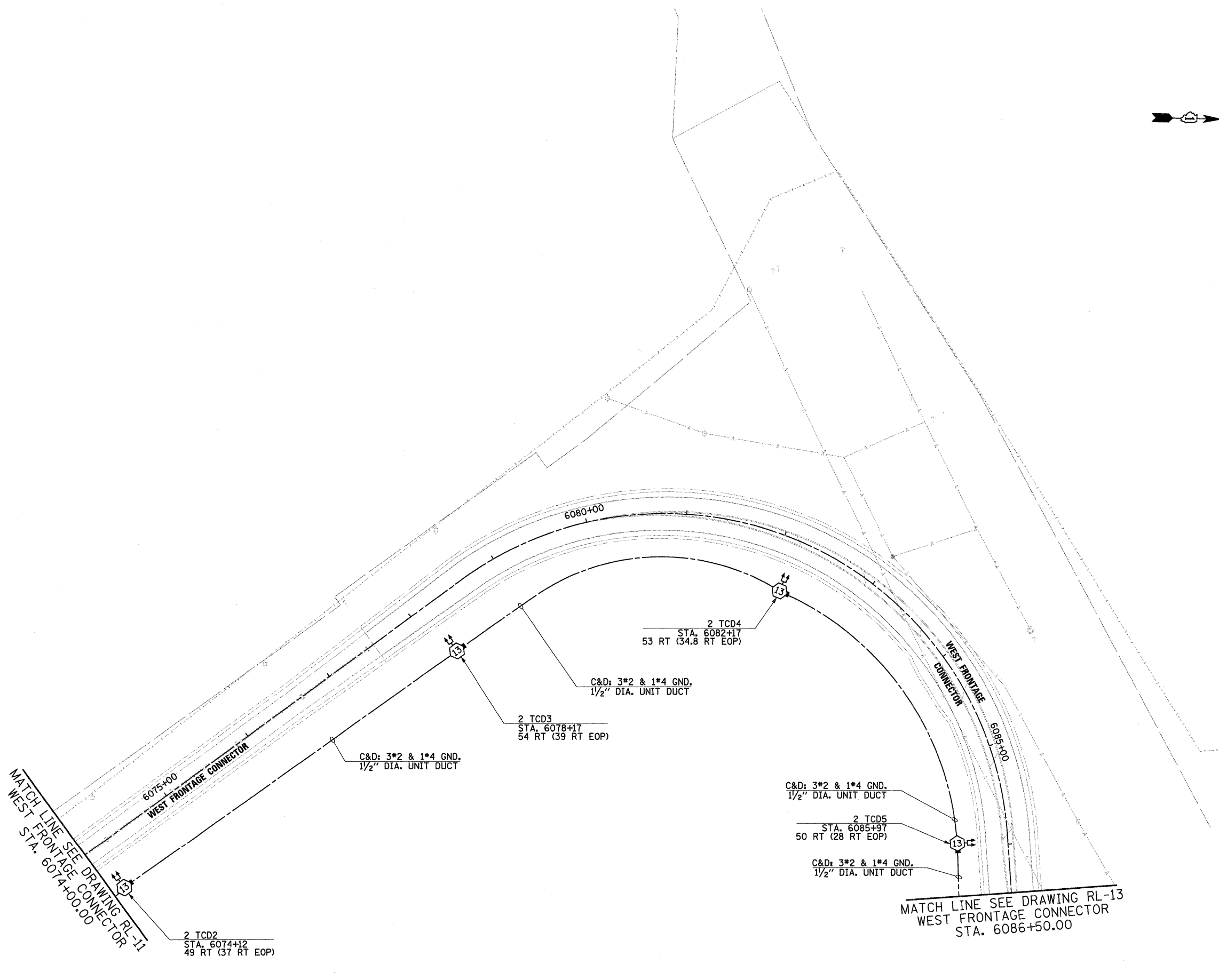
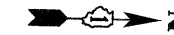

McDonough Associates Inc.
 Engineers / Architects
 130 East Randolph Street, Chicago, Illinois 60601

FILE NAME = D:\60F12-SHT-RL-12.dgn	USER NAME = TK1uege1	DESIGNED - JLW	REVISED -
PLOT SCALE = 1:50	CHECKED - KMY	DRAWN - CJM	REVISED -
PLOT DATE = 2/3/2011	DATE - 2/4/11	REVISOR -	REVISED -

STATE OF ILLINOIS
DEPARTMENT OF TRANSPORTATION

I-55 AT ARSENAL ROAD
PROPOSED ROADWAY LIGHTING PLAN FINAL CONDITIONS

SCALE: 1" = 50' SHEET NO. 12 OF 14 SHEETS STA. TO STA.

F.A.I. RTE. 55	SECTION 99-21B-2B-1	COUNTY WILL	TOTAL SHEETS 756	SHEET NO. 401
CONTRACT NO. 60F12				
FED. ROAD DIST. NO. 1 ILLINOIS FED. AID PROJECT				



NOTES:

- 1. SEE DRAWING GE-1 FOR ELECTRICAL SYMBOL LIST AND ABBREVIATIONS.
- 2. SEE DRAWING S-3 FOR HIGH MAST LIGHT TOWER FOUNDATION TABLE.
- 3. SEE DRAWING UL-2 FOR WEST FRONTAGE CONNECTOR UNDERPASS LIGHTING PLAN.

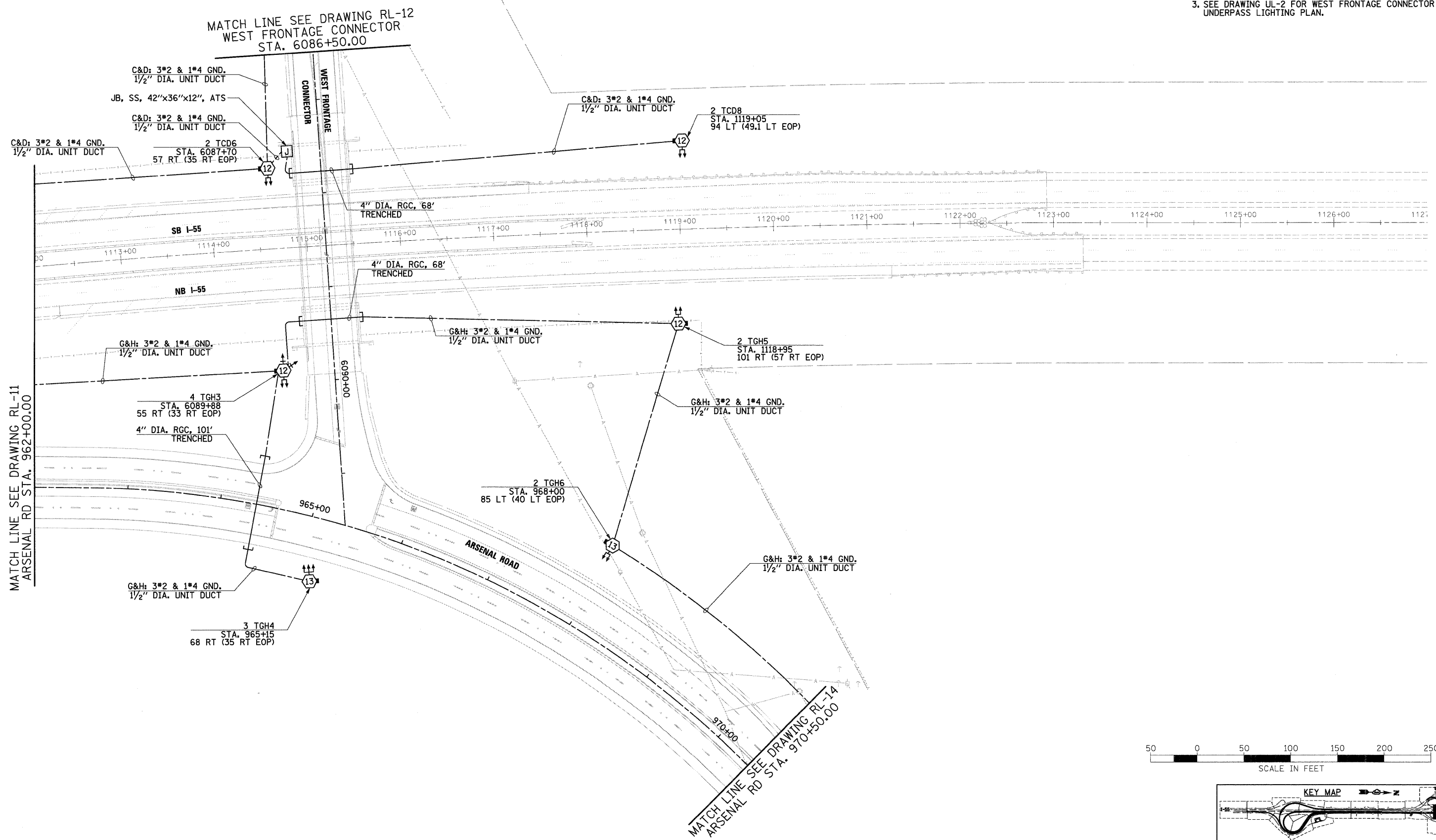

MATCH LINE SEE DRAWING RL-11
ARSENAL RD STA. 962+00.00

MATCH LINE SEE DRAWING RL-12
WEST FRONTAGE CONNECTOR
STA. 6086+50.00

MATCH LINE SEE DRAWING RL-14
ARSENAL RD STA. 970+50.00

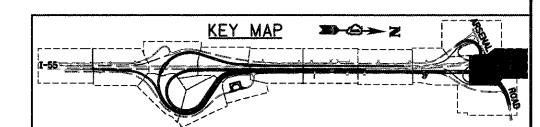
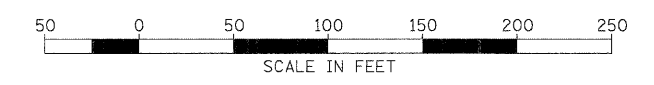

McDonough Associates Inc.
Engineers / Architects
130 East Randolph Street, Chicago, Illinois 60601

FILE NAME = D:\B2\F12-SHT-RL-13.dgn	USER NAME = TKJuegel	DESIGNED - JLW	REVISED -
		DRAWN - CJM	REVISED -
PLOT SCALE = 1/8"=1'		CHECKED - KMY	REVISED -
PLOT DATE = 2/3/2011		DATE - 2/4/11	REVISED -

**STATE OF ILLINOIS
DEPARTMENT OF TRANSPORTATION**

**I-55 AT ARSENAL ROAD
PROPOSED ROADWAY LIGHTING PLAN FINAL CONDITIONS**

SCALE: 1" = 50' SHEET NO. 13 OF 14 SHEETS STA. TO STA.

F.A.I. RTE.	SECTION	COUNTY	TOTAL SHEETS	SHEET NO.
55	99-2HB-2B-1	WILL	756	402
CONTRACT NO. 60F12			FED. ROAD DIST. NO. 1 ILLINOIS FED. AID PROJECT	

MATCH LINE SEE DRAWING RL-13
 ARSENAL RD STA. 970+50.00

G&H: 3*2 & 1*4 GND.
 1/2" DIA. UNIT DUCT

2 TGH7
 STA. 971+78
 76 LT (43 LT EOP)

G&H: 3*2 & 1*4 GND.
 1/2" DIA. UNIT DUCT

2 TGH8
 STA. 975+59
 74 LT (41 LT EOP)

G&H: 3*2 & 1*4 GND.
 1/2" DIA. UNIT DUCT

2 TGH9
 STA. 979+60
 71 LT (68 LT EOP)

NOTES:

1. SEE DRAWING GE-1 FOR ELECTRICAL SYMBOL LIST AND ABBREVIATIONS.
2. SEE DRAWING S-3 FOR HIGH MAST LIGHT TOWER FOUNDATION TABLE.

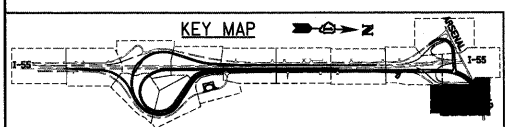
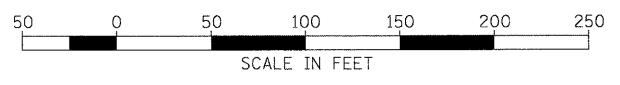

McDonough Associates Inc.
 Engineers / Architects
 130 East Randolph Street Chicago, Illinois 60601

FILE NAME = D:\B0\F12-SHT-RL-14.dgn	USER NAME = TKluegel	DESIGNED - JLW	REVISED -
	PLDT SCALE = 1:50	DRAWN - CJM	REVISED -
	PLDT DATE = 2/3/2011	CHECKED - KMY	REVISED -
		DATE - 2/4/11	REVISED -

STATE OF ILLINOIS
 DEPARTMENT OF TRANSPORTATION

I-55 AT ARSENAL ROAD
 PROPOSED ROADWAY LIGHTING PLAN FINAL CONDITIONS

SCALE: 1" = 50' SHEET NO. 14 OF 14 SHEETS STA. TO STA.

F.A.I. RTE.	SECTION	COUNTY	TOTAL SHEETS	SHEET NO.
55	99-2HB-2B-1	WILL	756	403
				CONTRACT NO. 60F12
FED. ROAD DIST. NO. 1 ILLINOIS FED. AID PROJECT				

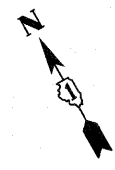

NOTES:

- SEE DRAWING GE-1 FOR ELECTRICAL SYMBOL LIST AND ABBREVIATIONS. SEE DRAWING GE-2 FOR ELECTRICAL GENERAL NOTES AND SUGGESTED LIGHTING PHASING NOTES.
- STATION AND OFFSET IN THIS CHART IS TO THE CENTER OF THE LUMINAIRE.
- BRIDGE JUNCTION BOX INSTALLED IN CONSTRUCTION STAGE 2. SEE DRAWINGS RL2-3 AND ED-3 FOR INSTALLATION DETAILS. JUNCTION BOX CONTAINS 30A FUSES AND SOLID SLUG FOR NEUTRAL CONDUCTOR. THIS WORK SHALL BE INCLUDED IN THE "JUNCTION BOX, STAINLESS STEEL, ATTACHED TO STRUCTURE, 42"x36"x12" PAY ITEM. SEPARATE PAYMENT WILL NOT BE MADE.
- FURNISH AND INSTALL JUNCTION BOXES FOR EACH UNDERPASS LUMINAIRE AS SHOWN ON THIS DRAWING AND IDOT STANDARD DRAWING BE-900. MOUNT JUNCTION BOXES UNDERNEATH BRIDGE DECK, CENTERED ABOVE UNDERPASS LUMINAIRE LOCATIONS. THIS WORK SHALL BE INCLUDED IN THE "JUNCTION BOX, STAINLESS STEEL, ATTACHED TO STRUCTURE, 6"x6"x4" PAY ITEM. SEPARATE PAYMENT WILL NOT BE MADE.
- FURNISH AND INSTALL UNDERPASS LUMINAIRES AS SHOWN ON THIS DRAWING AND IDOT STANDARD DRAWING BE-900. INCLUDE UNDERPASS LUMINAIRE HANGER ASSEMBLY COMPLETE WITH HEAVY DUTY ANCHORS/INSERTS, ALL APPLICABLE HARDWARE, 3/4" CONDUIT, AND 3/4" FLEXIBLE CONDUIT. FLARED LOOP INSERTS MUST BE CAST INTO THE CONCRETE DECK. LOCATE AND COORDINATE THE INSERT LOCATIONS WITH THE BRIDGE DECK CONTRACTOR. FURNISH AND INSTALL LUMINAIRE NUMBERING DECAL BRACKET AND DECAL. THIS WORK SHALL BE INCLUDED IN THE "UNDERPASS LUMINAIRE, 70 WATT, HIGH PRESSURE SODIUM VAPOR, STAINLESS STEEL HOUSING" PAY ITEM. SEPARATE PAYMENT WILL NOT BE MADE.

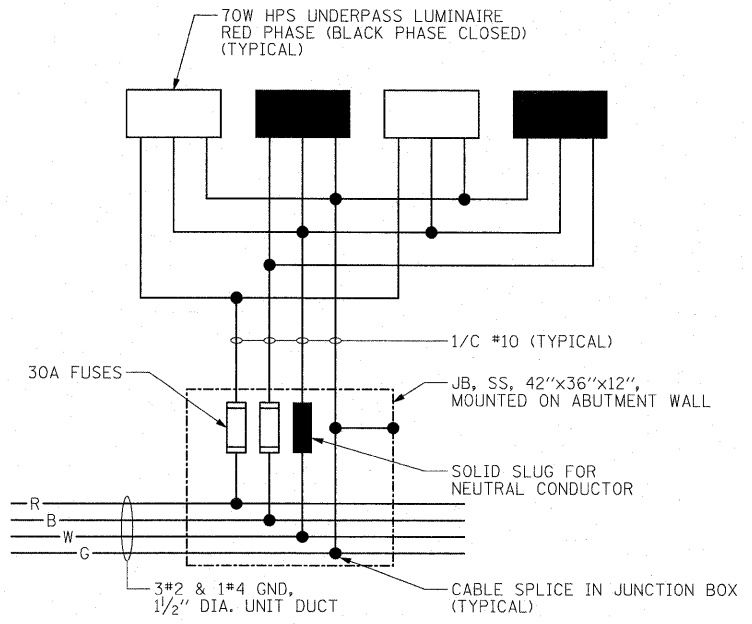
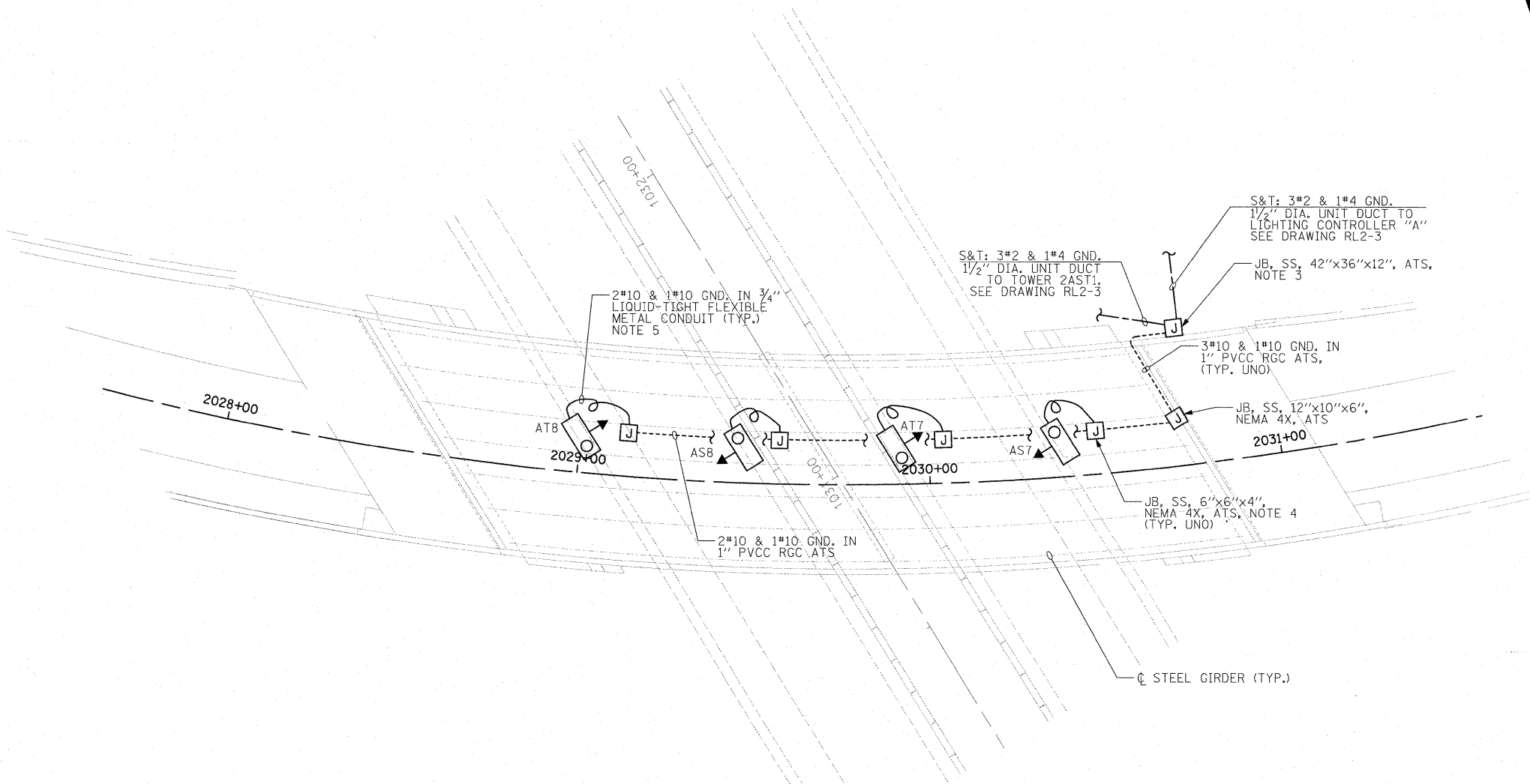

TYPICAL UNDERPASS LIGHTING UNIT WIRING DIAGRAM
N.T.S.

UNDERPASS FIXTURE NUMBER	UNDERPASS FIXTURE LOCATION (NOTE 2)		
	ROADWAY	STATION	CL OFFSET
AS7	SB I-55 EX.	2030+37.5	10'-1" LT
AT7	SB I-55 EX.	2029+90.5	10'-1" LT
AS8	SB I-55 EX.	2029+47	10'-1" LT
AT8	SB I-55 EX.	2029+00	10'-1" LT

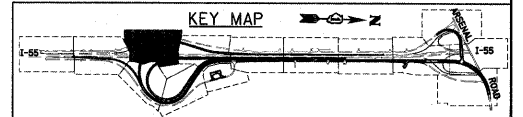
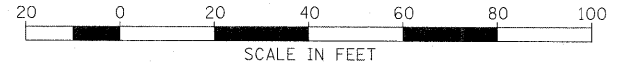

McDonough Associates Inc.
 Engineers / Architects
 130 East Randolph Street, Chicago, Illinois 60601

FILE NAME =
D160F12-SHT-UL-1.dgn

USER NAME = TKluergel

PLOT SCALE = 1:20

PLOT DATE = 3/7/2011

DESIGNED - J.L.W.

DRAWN - C.J.M.

CHECKED - K.M.Y.

DATE - 2/4/11

REVISED -

REVISED -

REVISED -

REVISED -

**STATE OF ILLINOIS
DEPARTMENT OF TRANSPORTATION**

**I-55 AT ARSENAL ROAD
RAMP C BRIDGE
UNDERPASS LIGHTING PLAN**

SCALE: 1" = 20' SHEET NO. 1 OF 1 SHEETS STA. TO STA.

F.A.I. RTE.	SECTION	COUNTY	TOTAL SHEETS	SHEET NO.
55	99-2HB-2B-1	WILL	756	404
CONTRACT NO. 60F12			FED. ROAD DIST. NO. 1 ILLINOIS FED. AID PROJECT	

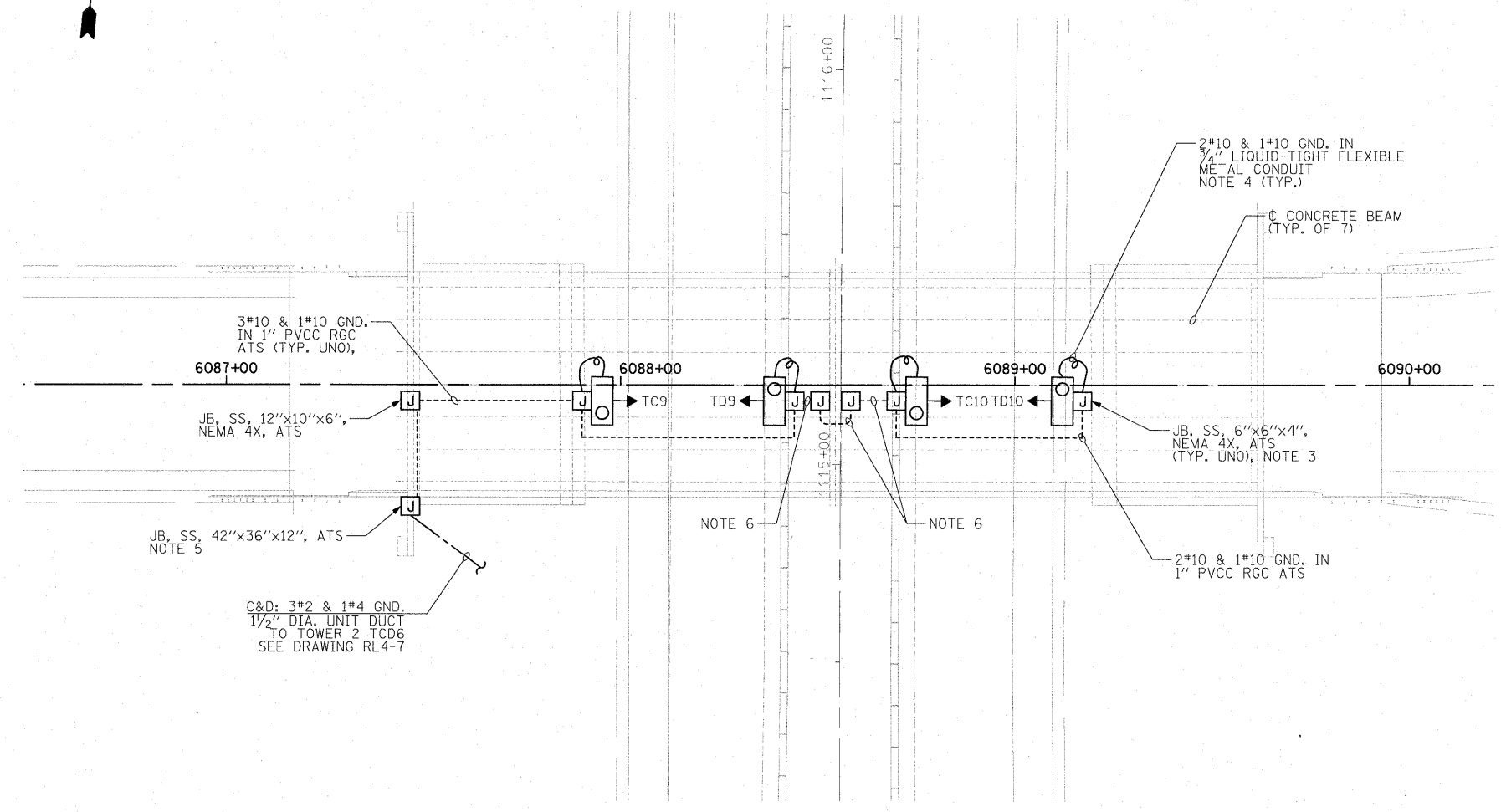

NOTES:

1. SEE DRAWING GE-1 FOR ELECTRICAL SYMBOL LIST AND ABBREVIATIONS. SEE DRAWING GE-2 FOR ELECTRICAL GENERAL NOTES AND SUGGESTED LIGHTING PHASING NOTES.
2. STATION AND OFFSET IN THIS CHART IS TO THE CENTER OF THE LUMINAIRE.
3. FURNISH AND INSTALL JUNCTION BOXES FOR EACH UNDERPASS LUMINAIRE AS SHOWN ON THIS DRAWING AND IDOT STANDARD DRAWING BE-900. MOUNT JUNCTION BOXES UNDERNEATH BRIDGE DECK, CENTERED ABOVE UNDERPASS LUMINAIRE LOCATIONS. THIS WORK SHALL BE INCLUDED IN THE "JUNCTION BOX, STAINLESS STEEL, ATTACHED TO STRUCTURE, 6"x6"x4" PAY ITEM. SEPARATE PAYMENT WILL NOT BE MADE.
4. FURNISH AND INSTALL UNDERPASS LUMINAIRES AS SHOWN ON THIS DRAWING AND IDOT STANDARD DRAWING BE-900. INCLUDE UNDERPASS LUMINAIRE HANGER ASSEMBLY COMPLETE WITH HEAVY DUTY ANCHORS/INSERTS, ALL APPLICABLE HARDWARE, 3/4" CONDUIT, AND 3/4" FLEXIBLE CONDUIT. FLARED LOOP INSERTS MUST BE CAST INTO THE CONCRETE DECK. LOCATE AND COORDINATE THE INSERT LOCATIONS WITH THE BRIDGE DECK CONTRACTOR. FURNISH AND INSTALL LUMINAIRE NUMBERING DECAL BRACKET AND DECAL. THIS WORK SHALL BE INCLUDED IN THE "UNDERPASS LUMINAIRE, 70 WATT, HIGH PRESSURE SODIUM VAPOR, STAINLESS STEEL HOUSING" PAY ITEM. SEPARATE PAYMENT WILL NOT BE MADE.
5. BRIDGE JUNCTION BOX. SEE DRAWING ED-4 FOR INSTALLATION DETAILS. JUNCTION BOX CONTAINS 30A FUSES AND SOLID SLUG FOR NEUTRAL CONDUCTOR. SEE DRAWING UL-1 FOR TYPICAL UNDERPASS LIGHTING UNIT WIRING DIAGRAM. THIS WORK SHALL BE INCLUDED IN THE "JUNCTION BOX, STAINLESS STEEL, ATTACHED TO STRUCTURE, 42"x36"x12" PAY ITEM. SEPARATE PAYMENT WILL NOT BE MADE.
6. ROUTE CONDUIT FROM UNDERPASS LUMINAIRE TC10 JUNCTION BOX DOWN EAST FACE OF PIER TO JUNCTION BOX. ROUTE CONDUIT FROM UNDERPASS LUMINAIRE TD9 JUNCTION BOX DOWN WEST FACE OF PIER TO JUNCTION BOX. CONNECT JUNCTION BOXES ON PIER TO EACH OTHER WITH CONDUIT ROUTED THROUGH OPEN AREA OF PIER FROM ONE SIDE TO THE OTHER. INCLUDE ALL PVC COATED CONDUIT CLAMPS OR BEAM CLAMPS.

UNDERPASS FIXTURE NUMBER	UNDERPASS FIXTURE LOCATION (NOTE 2)		
	ROADWAY	STATION	CL OFFSET
TC9	W. CONNECTOR	6087+97	4'-1 1/2" RT
TD9	W. CONNECTOR	6088+40	4'-1 1/2" RT
TC10	W. CONNECTOR	6088+76	4'-1 1/2" RT
TD10	W. CONNECTOR	6089+13	4'-1 1/2" RT

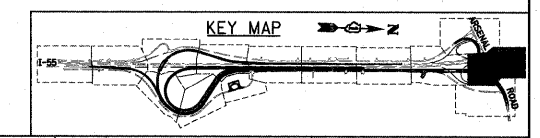
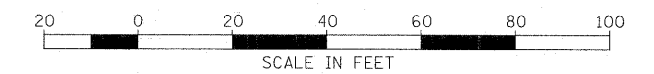

McDonough Associates Inc.
 Engineers / Architects
 180 East Randolph Street, Chicago, Illinois 60601

FILE NAME = D160F12-SHT-UL-2.dgn	USER NAME = TK1uegel	DESIGNED - DRAWN - CJM	REVISED - REVISED -
PLOT SCALE = 1:20	CHECKED -	REVISED -	REVISED -
PLOT DATE = 3/7/2011	DATE = 2/4/11	REVISED -	REVISED -

STATE OF ILLINOIS
DEPARTMENT OF TRANSPORTATION

I-55 AT ARSENAL ROAD
WEST FRONTAGE CONNECTOR BRIDGE
UNDERPASS LIGHTING PLAN

SCALE: 1" = 20' SHEET NO. 1 OF 1 SHEETS STA. TO STA.

F.A.I. RTE.	SECTION	COUNTY	TOTAL SHEETS	SHEET NO.
55	99-2HB-2B-1	WILL	756	405
CONTRACT NO. 60F12				

FED. ROAD DIST. NO. 1 | ILLINOIS | FED. AID PROJECT





EXISTING LIGHTING CONTROLLER "T" LOAD TABLE

CIRCUIT	RED PHASE		CIRCUIT	BLACK PHASE	
	AMPS	WATTS		AMPS	WATTS
A	14.0	3360	B	14.0	3360
C	21.0	5040	D	21.0	5040
E	21.0	5040	F	21.0	5040
G	--	--	H	--	--
I	--	--	J	--	--
K	--	--	L	--	--
M	--	--	N	--	--
O	--	--	P	--	--
Q	--	--	R	--	--
S	--	--	T	--	--
U	--	--	V	--	--
W	--	--	X	--	--
TOTAL	56.0	13440	TOTAL	56.0	13440

NOTES:

1. SEE DRAWING GE-1 FOR ELECTRICAL SYMBOL LIST AND ABBREVIATIONS.
2. CIRCUIT AND CABLE CALLOUTS ARE TYPICAL UNLESS NOTED OTHERWISE.

LEGEND:

-  EXISTING HIGH MAST LIGHT TOWER
750W HPS LUMINAIRES (TYP.)
(BLACK PHASE - SOLID SYMBOLS,
RED PHASE - OPEN SYMBOLS)
-  HIGH MAST TOWER DESIGNATION
-  LIGHTING CONTROLLER
-  GROUND FIELD
-  EXISTING ELECTRIC UTILITY SERVICE DROP

LOAD TABULATION IS BASED ON THE FOLLOWING:
750W HPS (HMT) LUMINAIRE: 3.5A AT 240V

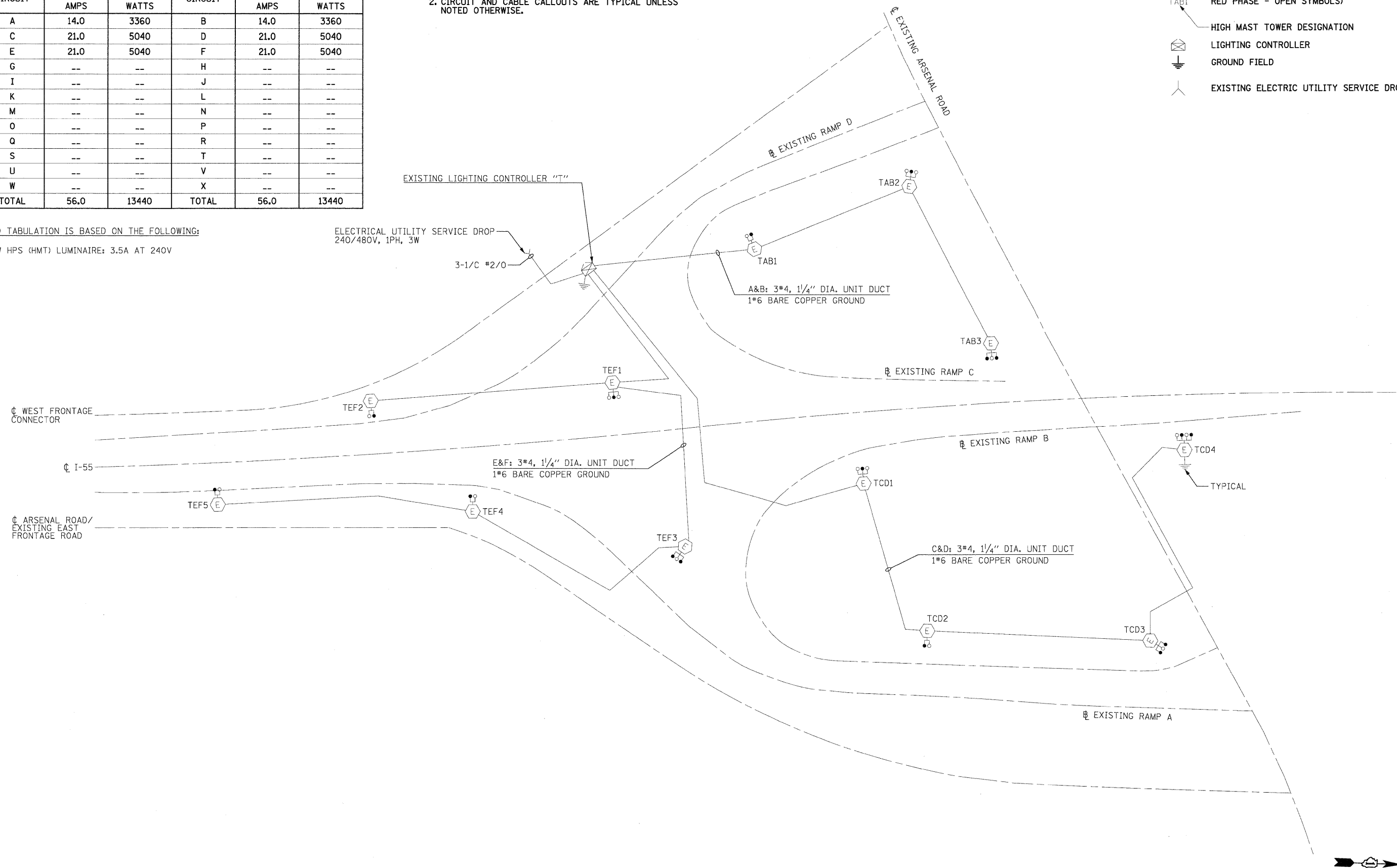

EXISTING LIGHTING CONTROLLER "T" LOAD TABLE (NOTE 3)

CIRCUIT	RED PHASE		CIRCUIT	BLACK PHASE	
	AMPS	WATTS		AMPS	WATTS
A	17.5	4200	B	17.5	4200
C*	28.0	6720	D*	24.5	5880
E	21.0	5040	F	17.5	4200
G	--	--	H	--	--
I	--	--	J	--	--
K	--	--	L	--	--
M	--	--	N	--	--
O	--	--	P	--	--
Q	--	--	R	--	--
S	--	--	T	--	--
U	--	--	V	--	--
W	--	--	X	--	--
TOTAL	66.5	15960	TOTAL	59.5	14280

NOTES:

- SEE DRAWING GE-1 FOR ELECTRICAL SYMBOL LIST AND ABBREVIATIONS. SEE DRAWING GE-2 FOR ELECTRICAL GENERAL NOTES AND SUGGESTED LIGHTING PHASING NOTES.
- CIRCUIT AND CABLE CALLOUTS ARE TYPICAL UNLESS NOTED OTHERWISE.
- BUCK-BOOST TRANSFORMER(S) INSIDE OF POLE MOUNTED, SS, NEMA 4X JUNCTION BOX, WIRED AFTER LUMINAIRES ON TEMPORARY LIGHT UNIT TTCD3.
- AMPS COLUMN INCLUDES ADDITIONAL AMPERAGE ON PRIMARY SIDE OF BUCK-BOOST TRANSFORMERS.
- SEE IDOT STANDARD DRAWING BE-800 FOR TEMPORARY LIGHT POLE ATTACHMENT DETAIL.

LEGEND:

- EXISTING HIGH MAST LIGHT TOWER 750W HPS LUMINAIRES (TYP.) (BLACK PHASE - SOLID SYMBOLS, RED PHASE - OPEN SYMBOLS)
- HIGH MAST TOWER DESIGNATION
- EXISTING LIGHTING CONTROLLER
- GROUND FIELD
- EXISTING ELECTRIC UTILITY SERVICE DROP
- TEMPORARY LIGHTING UNIT, 750 HPS LUMINAIRE (BLACK PHASE-SOLID SYMBOL, RED PHASE-OPEN SYMBOL)
- TEMPORARY AERIAL CABLE
- PROPOSED ELECTRIC UTILITY SERVICE DROP
- BUCK-BOOST TRANSFORMER ENCLOSURE

LOAD TABULATION IS BASED ON THE FOLLOWING:

750W HPS (HMT) LUMINAIRE: 3.5A AT 240V
 "*" SEE NOTE 4

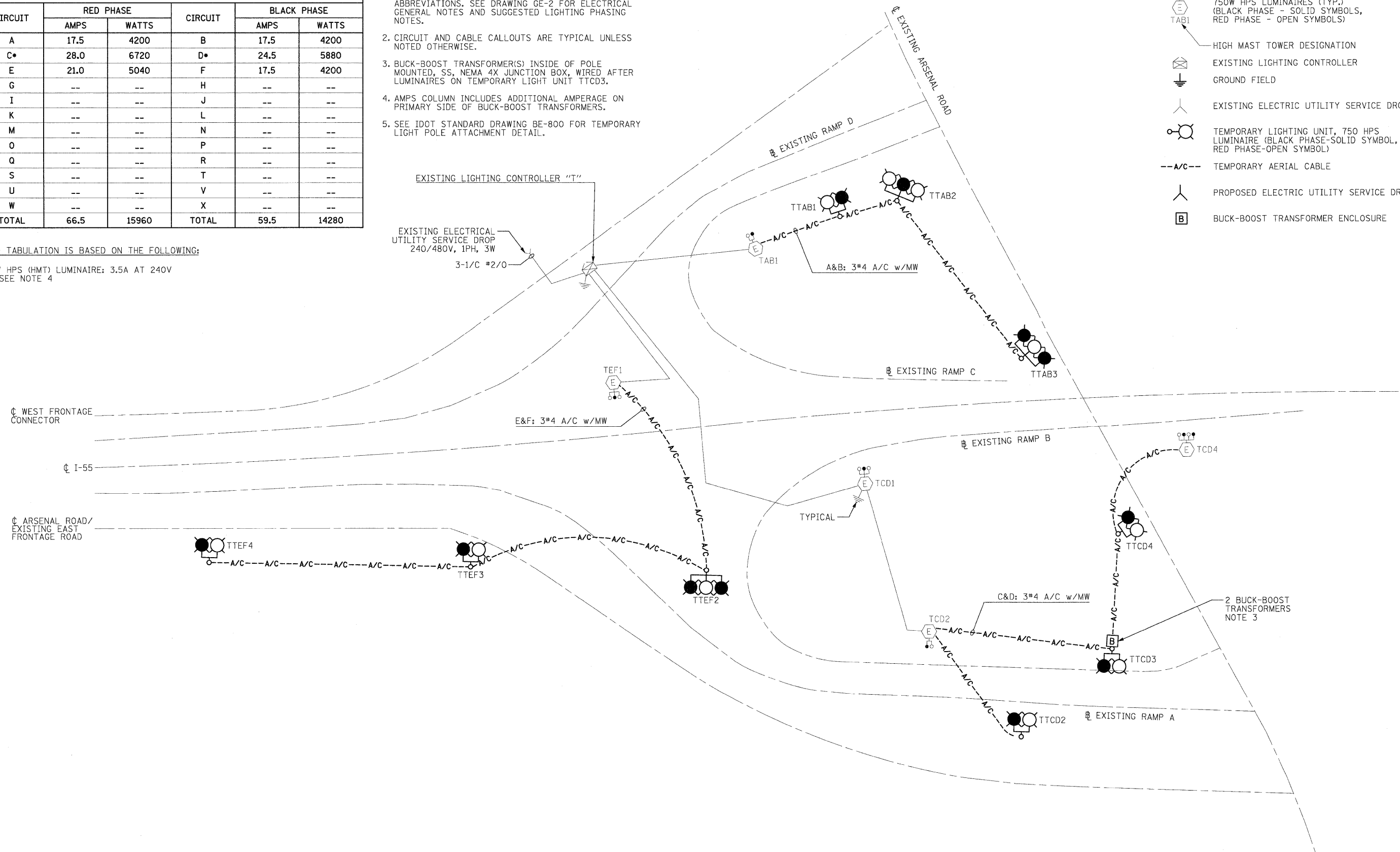

McDonough Associates Inc.
 Engineers / Architects
 130 East Randolph Street Chicago, Illinois 60601

FILE NAME = D:\160\F12-SHT-EW1-1.dgn	USER NAME = TKuegel	DESIGNED - JLW	REVISED -
		DRAWN - CJM	REVISED -
		CHECKED - KMY	REVISED -
		DATE - 2/4/11	REVISED -

STATE OF ILLINOIS
DEPARTMENT OF TRANSPORTATION

I-55 AT ARSENAL ROAD
EXISTING LIGHTING CONTROLLER "T" STAGE 1 SINGLE LINE DIAGRAM

SCALE: NONE SHEET NO. 1 OF 1 SHEETS STA. TO STA.

F.A.I R.T.E. 55	SECTION 99-2HB-2B-1	COUNTY WILL	TOTAL SHEETS 756	SHEET NO. 407
CONTRACT NO. 60F12			ILLINOIS FED. AID PROJECT	

PROPOSED LIGHTING CONTROLLER "T" LOAD TABLE

CIRCUIT	RED PHASE		CIRCUIT	BLACK PHASE	
	AMPS	WATTS		AMPS	WATTS
A	--	--	B	--	--
C	--	--	D	--	--
E	--	--	F	--	--
G	--	--	H	--	--
I	3.5	840	J	--	--
K	7.0	1680	L	7.0	1680
M	14.0	3360	N	10.5	2520
O	--	--	P	--	--
Q	--	--	R	--	--
S	--	--	T	--	--
U	--	--	V	--	--
W	--	--	X	--	--
TOTAL	24.5	5880	TOTAL	17.5	4200

NOTES:

1. SEE DRAWING GE-1 FOR ELECTRICAL SYMBOL LIST AND ABBREVIATIONS. SEE DRAWING GE-2 FOR ELECTRICAL GENERAL NOTES AND SUGGESTED LIGHTING PHASING NOTES.
2. CIRCUIT AND CABLE CALLOUTS ARE TYPICAL UNLESS NOTED OTHERWISE.
3. SEE IDOT STANDARD DRAWING BE-800 FOR TEMPORARY LIGHT POLE ATTACHMENT DETAIL.

LEGEND:

- EXISTING HIGH MAST LIGHT TOWER
750W HPS LUMINAIRES (TYP.)
(BLACK PHASE - SOLID SYMBOLS,
RED PHASE - OPEN SYMBOLS)
- HIGH MAST TOWER DESIGNATION
- PROPOSED LIGHTING CONTROLLER
- GROUND FIELD
- EXISTING ELECTRIC UTILITY SERVICE DROP
- TEMPORARY LIGHTING UNIT, 750 HPS
LUMINAIRE (BLACK PHASE-SOLID SYMBOL,
RED PHASE-OPEN SYMBOL)
- TEMPORARY AERIAL CABLE
- PROPOSED ELECTRIC UTILITY SERVICE DROP
- BUCK-BOOST TRANSFORMER ENCLOSURE

LOAD TABULATION IS BASED ON THE FOLLOWING:

750W HPS LUMINAIRE: 3.5A AT 240V

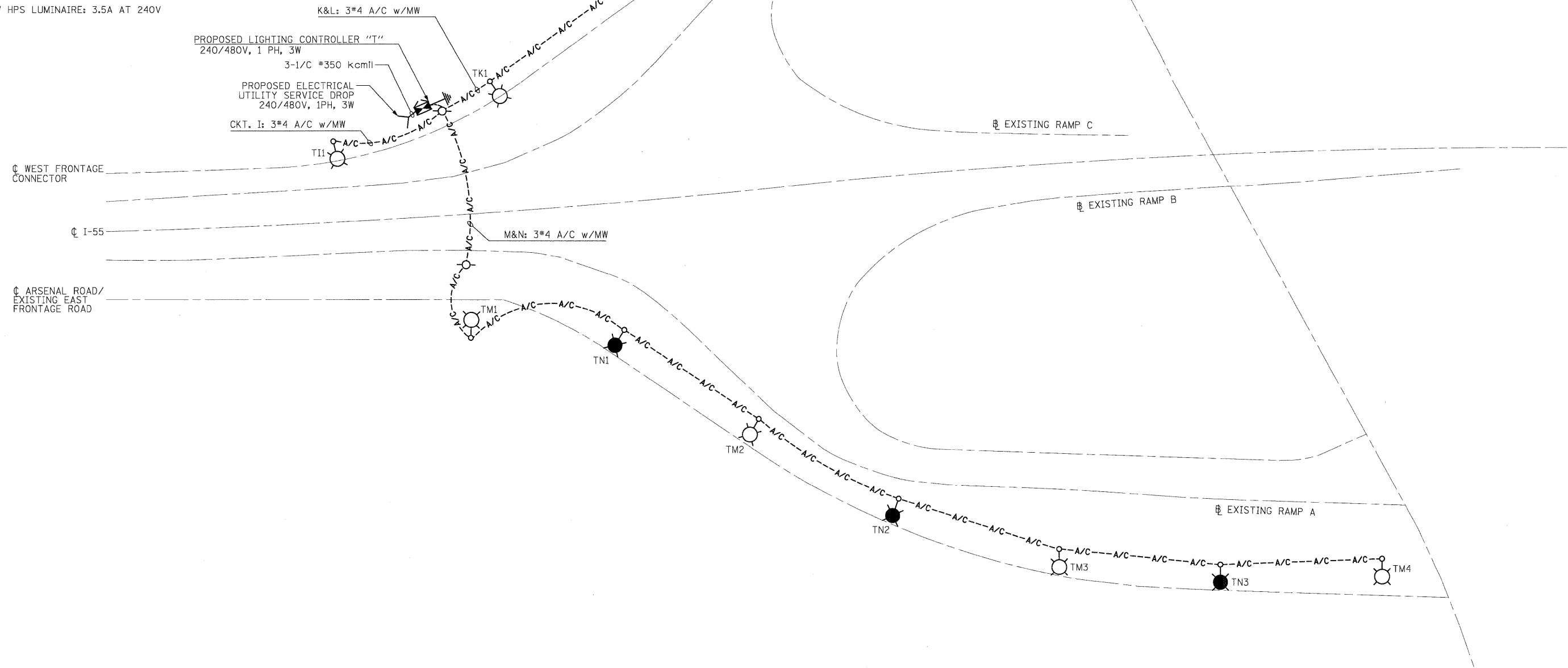

McDonough Associates Inc.
 Engineers / Architects
 130 East Randolph Street, Chicago, Illinois 60601

FILE NAME = D:\160F12-SHT-EW1-2.dgn	USER NAME = TKLuagel	DESIGNED - JLW	REVISED -
		DRAWN - CJM	REVISED -
		CHECKED - KMY	REVISED -
		DATE - 2/4/11	REVISED -

STATE OF ILLINOIS
DEPARTMENT OF TRANSPORTATION

I-55 AT ARSENAL ROAD
PROPOSED LIGHTING CONTROLLER "T" STAGE 1 SINGLE LINE DIAGRAM

SCALE: NONE SHEET NO. 1 OF 1 SHEETS STA. TO STA.

F.A.I R.T.E. 55	SECTION 99-2HB-2B-1	COUNTY WILL	TOTAL SHEETS 756	SHEET NO. 408
CONTRACT NO. 60F12			ILLINOIS FED. AID PROJECT	

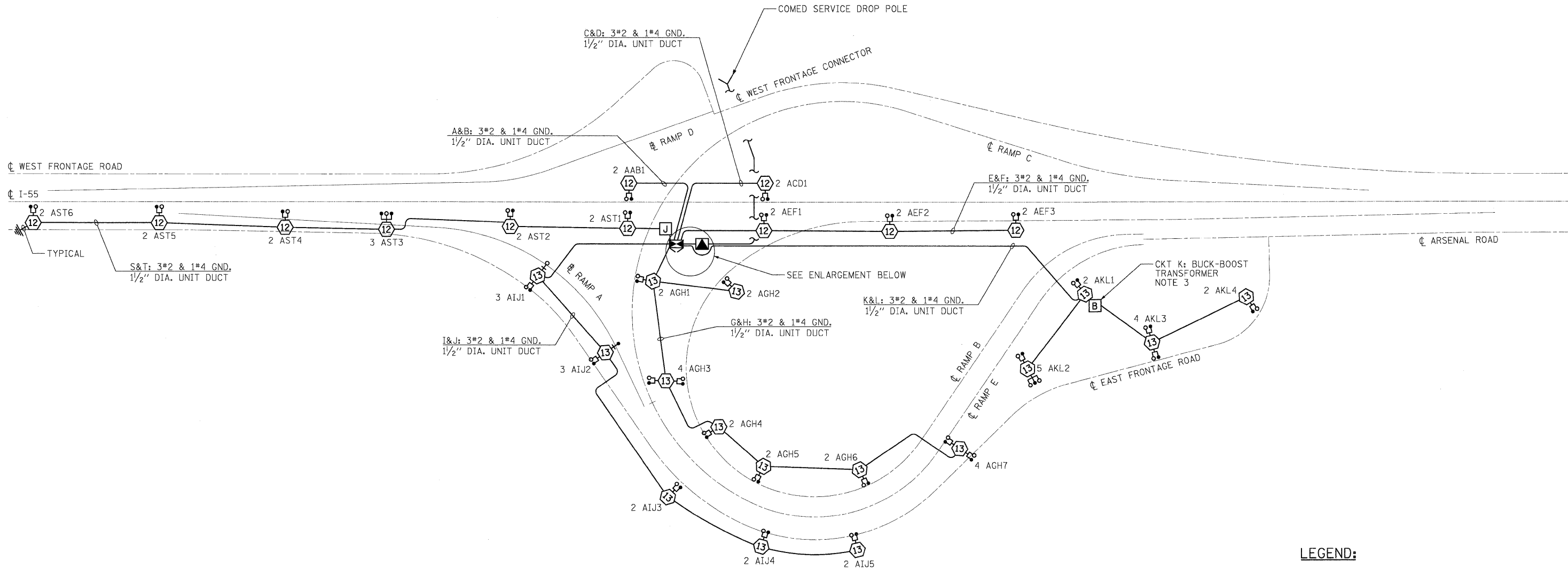

- LEGEND:**
- PROPOSED HIGH MAST LIGHT TOWER
750W HPS LUMINAIRE (TYP. U.N.O.)
(BLACK PHASE - SOLID SYMBOLS,
RED PHASE - OPEN SYMBOLS)
 - 12 120FT
13 130FT
HIGH MAST TOWER DESIGNATION
 - PROPOSED UNDERPASS LIGHTING UNIT
70W HPS LUMINAIRE (TYP. U.N.O.)
(BLACK PHASE - SOLID SYMBOLS,
RED PHASE - OPEN SYMBOLS)
 - LIGHTING CONTROLLER
 - GROUND FIELD
 - ELECTRIC UTILITY SERVICE DROP
 - BUCK-BOOST TRANSFORMER ENCLOSURE

LIGHTING CONTROLLER "A" LOAD TABLE					
CIRCUIT	RED PHASE		CIRCUIT	BLACK PHASE	
	AMPS	WATTS		AMPS	WATTS
A	3.5	840	B	3.5	840
C	3.5	840	D	3.5	840
E	10.5	2520	F	10.5	2520
G	31.5	7560	H	31.5	7560
I	21	5040	J	21	5040
K*	25.44	6107	L	21.94	5267
M	--	--	N	--	--
O	--	--	P	--	--
Q	--	--	R	--	--
S	21	5040	T	24.5	5880
U	--	--	V	--	--
W	--	--	X	--	--
TOTAL	116.44	27,947	TOTAL	116.44	27,947

- NOTES:**
- SEE DRAWING GE-1 FOR ELECTRICAL SYMBOL LIST AND ABBREVIATIONS. SEE DRAWING GE-2 FOR ELECTRICAL GENERAL NOTES AND SUGGESTED LIGHTING PHASING NOTES.
 - CIRCUIT AND CABLE CALLOUTS ARE TYPICAL UNLESS NOTED OTHERWISE.
 - BUCK-BOOST TRANSFORMER INSIDE OF TOWER MOUNTED, SS, NEMA 4X JUNCTION BOX. SEE DRAWING RL2-5, NOTE 6.
 - AMPS COLUMN INCLUDES ADDITIONAL AMPERAGE ON PRIMARY SIDE OF BUCK-BOOST TRANSFORMERS.
 - SEE IDOT STANDARD DRAWING BE-505c FOR HIGH MAST POLE WIRING DIAGRAM.

LOAD TABULATION IS BASED ON THE FOLLOWING:
750W HPS (HMT) LUMINAIRE: 3.5A AT 240V
**" SEE NOTE 4

McDonough Associates Inc.
 Engineers / Architects
 130 East Randolph Street, Chicago, Illinois 60601

FILE NAME = D:\B0F12-SHT-EW2-1.dgn	USER NAME = TKLuegel	DESIGNED - JLW	REVISED -	STATE OF ILLINOIS DEPARTMENT OF TRANSPORTATION	I-55 AT ARSENAL ROAD PROPOSED LIGHTING CONTROLLER "A" STAGE 2 SINGLE LINE DIAGRAM	F.A.I. RTE. 55	SECTION 99-2HB-2B-1	COUNTY WILL	TOTAL SHEETS 756	SHEET NO. 409	
PLOT SCALE = 1:200	CHECKED - KMY	REVISED -	SCALE: 1" = 50'			SHEET NO. 1 OF 1 SHEETS	STA. TO STA.	FED. ROAD DIST. NO. 1 ILLINOIS FED. AID PROJECT			
PLOT DATE = 2/3/2011	DATE - 2/4/11	REVISED -									
CONTRACT NO. 60F12											

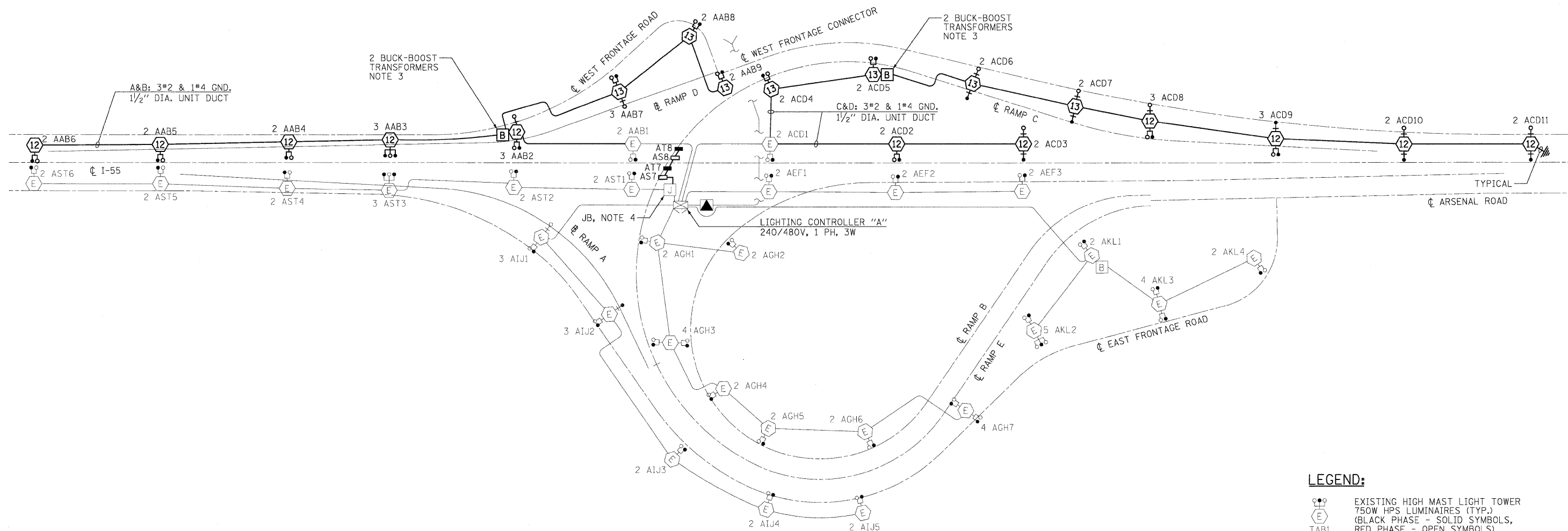

LEGEND:

- EXISTING HIGH MAST LIGHT TOWER
750W HPS LUMINAIRE (TYP.)
(BLACK PHASE - SOLID SYMBOLS,
RED PHASE - OPEN SYMBOLS)
- HIGH MAST TOWER DESIGNATION
- PROPOSED HIGH MAST LIGHT TOWER
750W HPS LUMINAIRE (TYP. U.N.O.)
(BLACK PHASE - SOLID SYMBOLS,
RED PHASE - OPEN SYMBOLS)
- HIGH MAST TOWER DESIGNATION
12 120FT
13 130FT
- PROPOSED UNDERPASS LIGHTING UNIT
70W HPS LUMINAIRE (TYP. U.N.O.)
(BLACK PHASE - SOLID SYMBOLS,
RED PHASE - OPEN SYMBOLS)
- LIGHTING CONTROLLER
- GROUND FIELD
- ELECTRIC UTILITY SERVICE DROP
- BUCK-BOOST TRANSFORMER ENCLOSURE

LIGHTING CONTROLLER "A" LOAD TABLE

CIRCUIT	RED PHASE		CIRCUIT	BLACK PHASE	
	AMPS	WATTS		AMPS	WATTS
A	38.5	9240	B	35	8400
C*	44.2	10609	D*	44.2	10609
E	10.5	2520	F	10.5	2520
G	31.5	7560	H	31.5	7560
I	21	5040	J	21	5040
K*	25.44	6107	L	21.94	5267
M	--	--	N	--	--
O	--	--	P	--	--
Q	--	--	R	--	--
S	21.86	6910	T	25.36	6910
U	--	--	V	--	--
W	--	--	X	--	--
TOTAL	193.00	46,320	TOTAL	189.50	45,480

NOTES:

1. SEE DRAWING GE-1 FOR ELECTRICAL SYMBOL LIST AND ABBREVIATIONS. SEE DRAWING GE-2 FOR ELECTRICAL GENERAL NOTES AND SUGGESTED LIGHTING PHASING NOTES.
2. CIRCUIT AND CABLE CALLOUTS ARE TYPICAL UNLESS NOTED OTHERWISE.
3. BUCK-BOOST TRANSFORMERS INSIDE OF TOWER MOUNTED, SS, NEMA 4X JUNCTION BOX. SEE DRAWING RL3-3, NOTE 7.
4. UNDERPASS LIGHTING UNITS WIRED WITH 3*10 AND 1*10 GND IN 1" PVCC RGC FROM UNIT TO UNIT. REFER TO DRAWING UL-1 FOR TYPICAL UNDERPASS LIGHTING UNIT WIRING DIAGRAM.
5. AMPS COLUMN INCLUDES ADDITIONAL AMPERAGE ON PRIMARY SIDE OF BUCK-BOOST TRANSFORMERS.
6. SEE IDOT STANDARD DRAWING BE-505c FOR HIGH MAST POLE WIRING DIAGRAM.

LOAD TABULATION IS BASED ON THE FOLLOWING:

750W HPS (HMT) LUMINAIRE: 3.5A AT 240V
70W HPS UNDERPASS LUMINAIRE: 0.43A AT 240V
* SEE NOTE 5



PROPOSED LIGHTING CONTROLLER "T" LOAD TABLE					
CIRCUIT	RED PHASE		CIRCUIT	BLACK PHASE	
	AMPS	WATTS		AMPS	WATTS
A	24.5	5880	B	24.5	5880
C	--	--	D	--	--
E	--	--	F	--	--
G	--	--	H	--	--
I	3.5	840	J	--	--
K	7.0	1680	L	7.0	1680
M	14.0	3360	N	10.5	2520
O	--	--	P	--	--
Q	--	--	R	--	--
S	--	--	T	--	--
U	--	--	V	--	--
W	--	--	X	--	--
TOTAL	49.0	11760	TOTAL	42.0	10080

NOTES:

- SEE DRAWING GE-1 FOR ELECTRICAL SYMBOL LIST AND ABBREVIATIONS. SEE DRAWING GE-2 FOR ELECTRICAL GENERAL NOTES AND SUGGESTED LIGHTING PHASING NOTES.
- CIRCUIT AND CABLE CALLOUTS ARE TYPICAL UNLESS NOTED OTHERWISE.
- SEE IDOT STANDARD DRAWING BE-505c FOR HIGH MAST POLE WIRING DIAGRAM.

LEGEND:

- PROPOSED HIGH MAST LIGHT TOWER 750W HPS LUMINAIRE (TYP. U.N.O.) (BLACK PHASE - SOLID SYMBOLS, RED PHASE - OPEN SYMBOLS)
- 12 120FT
13 130FT
- HIGH MAST TOWER DESIGNATION
- EXISTING LIGHTING CONTROLLER
- GROUND FIELD
- EXISTING ELECTRIC UTILITY SERVICE DROP
- EXISTING TEMPORARY LIGHTING UNIT, 750 HPS LUMINAIRE (BLACK PHASE-SOLID SYMBOL, RED PHASE-OPEN SYMBOL)
- A/C-- EXISTING TEMPORARY AERIAL CABLE

LOAD TABULATION IS BASED ON THE FOLLOWING:

750W HPS LUMINAIRE: 3.5A AT 240V

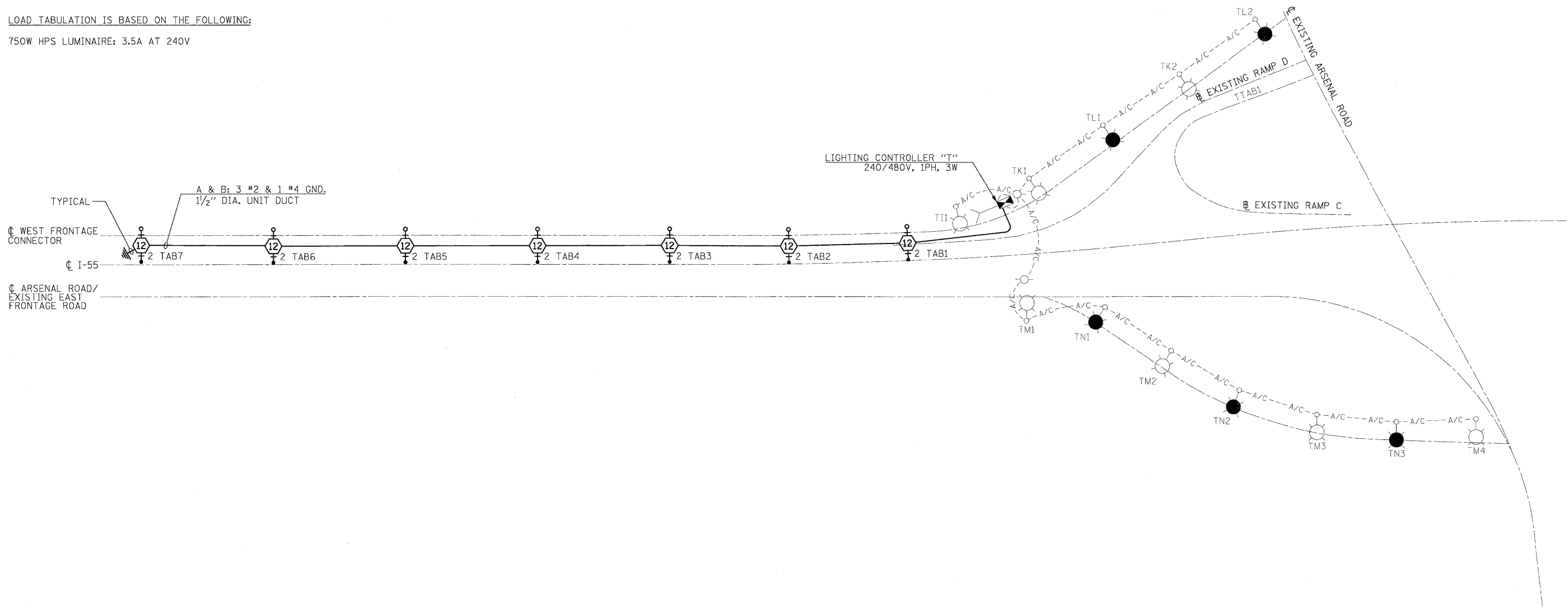

McDonough Associates Inc.
 Engineers / Architects
 130 East Randolph Street, Chicago, Illinois 60601

FILE NAME = D160F12-SHT-EW3-2.dgn	USER NAME = TKluigel	DESIGNED - JLW	REVISED -
		DRAWN - CJM	REVISED -
		CHECKED - KMY	REVISED -
		DATE - 2/4/11	REVISED -

STATE OF ILLINOIS
DEPARTMENT OF TRANSPORTATION

I-55 AT ARSENAL ROAD
PROPOSED LIGHTING CONTROLLER "T" STAGE 3 SINGLE LINE DIAGRAM

SCALE: NONE SHEET NO. 1 OF 1 SHEETS STA. TO STA.

F.A.I. RTE. 55	SECTION 99-2HB-2B-1	COUNTY WILL	TOTAL SHEETS 756	SHEET NO. 411
CONTRACT NO. 60F12				
FED. ROAD DIST. NO. 1 ILLINOIS FED. AID PROJECT				

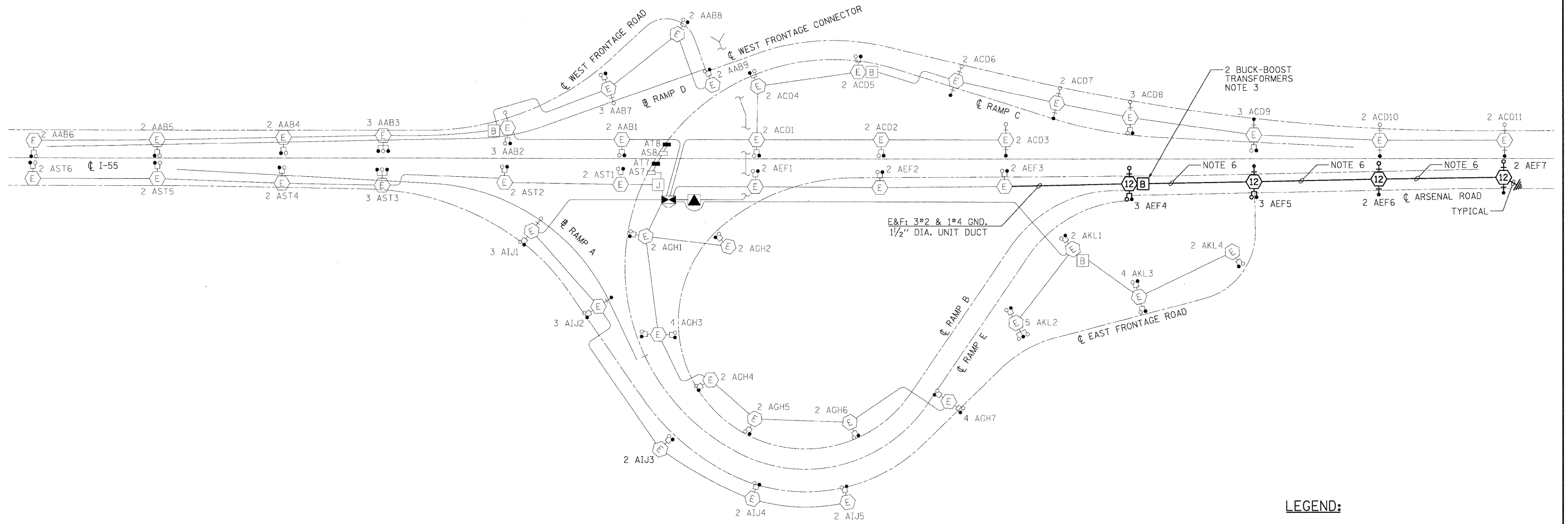

- LEGEND:**
- EXISTING HIGH MAST LIGHT TOWER
750W HPS LUMINAIRE (TYP.)
(BLACK PHASE - SOLID SYMBOLS,
RED PHASE - OPEN SYMBOLS)
 - HIGH MAST TOWER DESIGNATION
 - PROPOSED HIGH MAST LIGHT TOWER
750W HPS LUMINAIRE (TYP. U.N.O.)
(BLACK PHASE - SOLID SYMBOLS,
RED PHASE - OPEN SYMBOLS)
 - HIGH MAST TOWER DESIGNATION
12 120FT
13 130FT
 - PROPOSED UNDERPASS LIGHTING UNIT
70W HPS LUMINAIRE (TYP. U.N.O.)
(BLACK PHASE - SOLID SYMBOLS,
RED PHASE - OPEN SYMBOLS)
 - LIGHTING CONTROLLER
 - GROUND FIELD
 - ELECTRIC UTILITY SERVICE DROP
 - BUCK-BOOST TRANSFORMER ENCLOSURE

LIGHTING CONTROLLER "A" LOAD TABLE

CIRCUIT	RED PHASE		CIRCUIT	BLACK PHASE	
	AMPS	WATTS		AMPS	WATTS
A*	37.52	9005	B*	37.52	9005
C*	44.2	10609	D*	44.2	10609
E*	28.95	6947	F*	29.26	7022
G	31.5	7560	H	31.5	7560
I	21	5040	J	21	5040
K*	25.44	6107	L	21.94	5267
M	--	--	N	--	--
O	--	--	P	--	--
Q	--	--	R	--	--
S	21.86	5246	T	25.36	6086
U	--	--	V	--	--
W	--	--	X	--	--
TOTAL	210.47	50,514	TOTAL	210.78	50,589

- NOTES:**
- SEE DRAWING GE-1 FOR ELECTRICAL SYMBOL LIST AND ABBREVIATIONS. SEE DRAWING GE-2 FOR ELECTRICAL GENERAL NOTES AND SUGGESTED LIGHTING PHASING NOTES.
 - CIRCUIT AND CABLE CALLOUTS ARE TYPICAL UNLESS NOTED OTHERWISE.
 - BUCK-BOOST TRANSFORMERS INSIDE OF TOWER MOUNTED, SS, NEMA 4X JUNCTION BOX. SEE DRAWING RL4-1, NOTE 6 FOR TYPICAL BUCK-BOOST TRANSFORMER INFORMATION.
 - AMPS COLUMN INCLUDES ADDITIONAL AMPERAGE ON PRIMARY SIDE OF BUCK-BOOST TRANSFORMERS.
 - SEE IDOT STANDARD DRAWING BE-505c FOR HIGH MAST POLE WIRING DIAGRAM.
 - CKTS. E&F: 3*2 & 1*4 GND. ECA.

LOAD TABULATION IS BASED ON THE FOLLOWING:
 750W HPS (HMT) LUMINAIRE: 3.5A AT 240V
 70W HPS UNDERPASS LUMINAIRE: 0.43A AT 240V
 * SEE NOTE 4

McDonough Associates Inc.
 Engineers / Architects
 130 East Randolph Street, Chicago, Illinois 60601

FILE NAME =
 D:\60F12-SHT-EW4-1.dgn

USER NAME = TKluagel
 PI OT. SCAI. F = 1/200
 PLOT DATE = 2/3/2011

DESIGNED - JLW
 DRAWN - CJM
 CHECKED - KMY
 DATE - 2/4/11

REVISED -
 REVISED -
 REVISED -
 REVISED -

**STATE OF ILLINOIS
 DEPARTMENT OF TRANSPORTATION**

**I-55 AT ARSENAL ROAD
 PROPOSED LIGHTING CONTROLLER "A" STAGE 4 SINGLE LINE DIAGRAM**

SCALE: 1" = 50' SHEET NO. 1 OF 1 SHEETS STA. TO STA.

F.A.I. RTE.	SECTION	COUNTY	TOTAL SHEETS	SHEET NO.
55	99-2HB-2B-1	WILL	756	412
FED. ROAD DIST. NO. 1 ILLINOIS FED. AID PROJECT			CONTRACT NO. 60F12	

PROPOSED LIGHTING CONTROLLER "T" LOAD TABLE

CIRCUIT	RED PHASE		CIRCUIT	BLACK PHASE	
	AMPS	WATTS		AMPS	WATTS
A	24.5	5880	B	24.5	5880
C	32.36	7750	D	28.86	6910
E*	32.76	7862	F*	29.26	7022
G*	44.8	10760	H*	41.02	9845
I	--	--	J	--	--
K	--	--	L	--	--
M	--	--	N	--	--
O	--	--	P	--	--
Q	--	--	R	--	--
S	--	--	T	--	--
U	--	--	V	--	--
W	--	--	X	--	--
TOTAL	130.92	31,412	TOTAL	123.64	29,657

NOTES:

- SEE DRAWING GE-1 FOR ELECTRICAL SYMBOL LIST AND ABBREVIATIONS. SEE DRAWING GE-2 FOR ELECTRICAL GENERAL NOTES AND SUGGESTED LIGHTING PHASING NOTES.
- BUCK-BOOST TRANSFORMERS INSIDE OF TOWER MOUNTED, SS, NEMA 4X JUNCTION BOXES. SEE DRAWING RL4-1, NOTE 6 FOR TYPICAL BUCK-BOOST TRANSFORMER INFORMATION.
- UNDERPASS LIGHTING UNITS WIRED WITH 3*10 AND 1*10 GND IN 1" PVCC RGC FROM UNIT TO UNIT. REFER TO DRAWING UL-1 FOR TYPICAL UNDERPASS LIGHTING UNIT WIRING DIAGRAM.
- AMPS COLUMN INCLUDES ADDITIONAL AMPERAGE ON PRIMARY SIDE OF BUCK-BOOST TRANSFORMERS.
- SEE IDOT STANDARD DRAWING BE-505c FOR HIGH MAST POLE WIRING DIAGRAM.
- CKTS E&F: 3*2 & 1*4 GND. ECA.

LEGEND:

- EXISTING HIGH MAST LIGHT TOWER
750W HPS LUMINAIRE (TYP.)
(BLACK PHASE - SOLID SYMBOLS,
RED PHASE - OPEN SYMBOLS)
- HIGH MAST TOWER DESIGNATION
- PROPOSED HIGH MAST LIGHT TOWER
750W HPS LUMINAIRE (TYP. U.N.O.)
(BLACK PHASE - SOLID SYMBOLS,
RED PHASE - OPEN SYMBOLS)
- HIGH MAST TOWER DESIGNATION
12 120FT
13 130FT
- PROPOSED UNDERPASS LIGHTING UNIT
70W HPS LUMINAIRE (TYP. U.N.O.)
(BLACK PHASE - SOLID SYMBOLS,
RED PHASE - OPEN SYMBOLS)
- LIGHTING CONTROLLER
- GROUND FIELD
- ELECTRIC UTILITY SERVICE DROP
- BUCK-BOOST TRANSFORMER ENCLOSURE

LOAD TABULATION IS BASED ON THE FOLLOWING:

750W HPS (HMT) LUMINAIRE: 3.5A AT 240V
70W HPS UNDERPASS LUMINAIRE: 0.43A AT 240V
* SEE NOTE 4

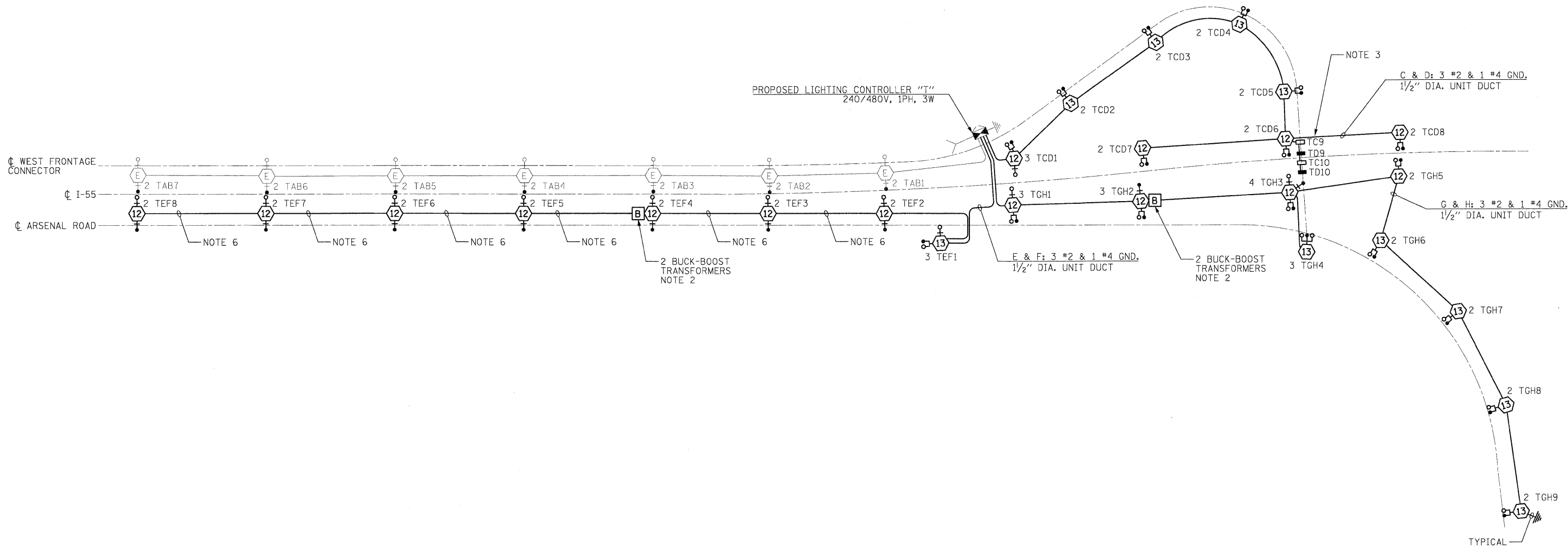

FILE NAME = D:\00F12-SHT-EW4-2.dgn	USER NAME = TKJuegel	DESIGNED - JLW	REVISED -
		DRAWN - CJM	REVISED -
		CHECKED - KMY	REVISED -
		DATE - 2/4/11	REVISED -

**STATE OF ILLINOIS
DEPARTMENT OF TRANSPORTATION**

**I-55 AT ARSENAL ROAD
PROPOSED LIGHTING CONTROLLER "T" STAGE 4 SINGLE LINE DIAGRAM**

SCALE: NONE SHEET NO. 1 OF 1 SHEETS STA. TO STA.

F.A.I. RTE.	SECTION	COUNTY	TOTAL SHEETS	SHEET NO.
55	99-2HB-2B-1	WILL	756	413
CONTRACT NO. 60F12			ILLINOIS/FED. AID PROJECT	

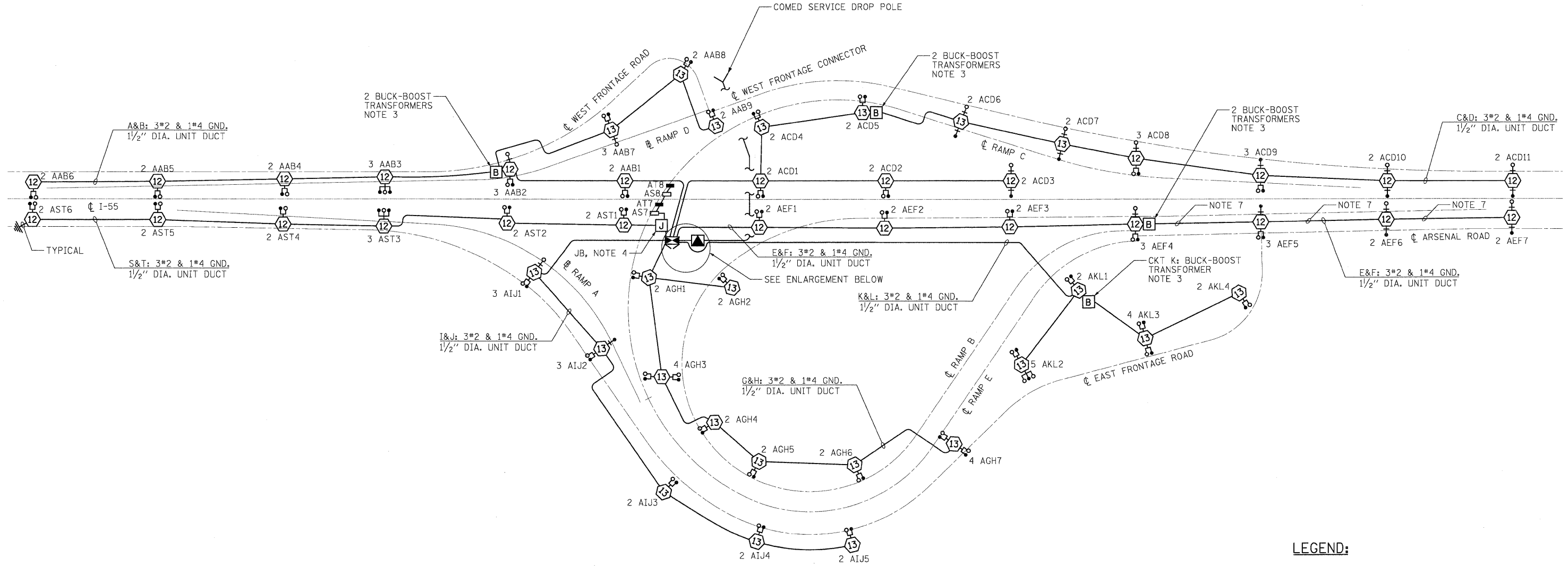

LEGEND:

- PROPOSED HIGH MAST LIGHT TOWER
750W HPS LUMINAIRE (TYP. U.N.O.)
(BLACK PHASE - SOLID SYMBOLS,
RED PHASE - OPEN SYMBOLS)
- HIGH MAST TOWER DESIGNATION
12 120FT
13 130FT
- PROPOSED UNDERPASS LIGHTING UNIT
70W HPS LUMINAIRE (TYP. U.N.O.)
(BLACK PHASE - SOLID SYMBOLS,
RED PHASE - OPEN SYMBOLS)
- LIGHTING CONTROLLER
- GROUND FIELD
- ELECTRIC UTILITY SERVICE DROP
- BUCK-BOOST TRANSFORMER ENCLOSURE

- NOTES:**
- SEE DRAWING GE-1 FOR ELECTRICAL SYMBOL LIST AND ABBREVIATIONS. SEE DRAWING GE-2 FOR ELECTRICAL GENERAL NOTES AND SUGGESTED LIGHTING PHASING NOTES.
 - CIRCUIT AND CABLE CALLOUTS ARE TYPICAL UNLESS NOTED OTHERWISE.
 - BUCK-BOOST TRANSFORMERS INSIDE OF TOWER MOUNTED, SS, NEMA 4X JUNCTION BOXES. SEE DRAWING RL2-5, NOTE 6 FOR TYPICAL BUCK-BOOST TRANSFORMER INFORMATION.
 - UNDERPASS LIGHTING UNITS WIRED WITH 3*10 AND 1*10 GND IN 1" PVCC RGC FROM UNIT TO UNIT. SEE DRAWING UL-1 FOR TYPICAL UNDERPASS LIGHTING UNIT WIRING DIAGRAM.
 - AMPS COLUMN INCLUDES ADDITIONAL AMPERAGE ON PRIMARY SIDE OF BUCK-BOOST TRANSFORMERS.
 - SEE IDOT STANDARD DRAWING BE-505c FOR HIGH MAST POLE WIRING DIAGRAM.
 - CKTS E&F: 3*2 & 1*4 GND, ECA.

LIGHTING CONTROLLER "A" LOAD TABLE					
CIRCUIT	RED PHASE		CIRCUIT	BLACK PHASE	
	AMPS	WATTS		AMPS	WATTS
A*	37.52	9005	B*	37.52	9005
C*	44.2	10609	D*	44.2	10609
E*	28.95	6947	F*	29.26	7022
G	31.5	7560	H	31.5	7560
I	21	5040	J	21	5040
K*	25.44	6107	L	21.94	5267
M	--	--	N	--	--
O	--	--	P	--	--
Q	--	--	R	--	--
S	21.86	5246	T	25.36	6086
U	--	--	V	--	--
W	--	--	X	--	--
TOTAL	210.47	50,514	TOTAL	210.78	50,589

LOAD TABULATION IS BASED ON THE FOLLOWING:
 750W HPS (HMT) LUMINAIRE: 3.5A AT 240V
 70W HPS UNDERPASS LUMINAIRE: 0.43A AT 240V
 "*" SEE NOTE 5

FILE NAME = D:\60F12-SHT-EW-1.dgn	USER NAME = TKLuegel	DESIGNED - JLW	REVISED -
PLDT SCALE = 1:200	CHECKED - KMY	DRAWN - CJM	REVISED -
PLDT DATE = 2/3/2011	DATE = 2/4/11		REVISED -

LIGHTING CONTROLLER "T" LOAD TABLE					
CIRCUIT	RED PHASE		CIRCUIT	BLACK PHASE	
	AMPS	WATTS		AMPS	WATTS
A	24.5	5880	B	24.5	5880
C	32.36	7750	D	28.86	6910
E*	32.76	7862	F*	29.26	7022
G*	44.8	10760	H*	41.02	9845
I	--	--	J	--	--
K	--	--	L	--	--
M	--	--	N	--	--
O	--	--	P	--	--
Q	--	--	R	--	--
S	--	--	T	--	--
U	--	--	V	--	--
W	--	--	X	--	--
TOTAL	130.92	31,412	TOTAL	123.64	29,657

NOTES:

- SEE DRAWING GE-1 FOR ELECTRICAL SYMBOL LIST AND ABBREVIATIONS. SEE DRAWING GE-2 FOR ELECTRICAL GENERAL NOTES AND SUGGESTED LIGHTING PHASING NOTES.
- CIRCUIT AND CABLE CALLOUTS ARE TYPICAL UNLESS NOTED OTHERWISE.
- BUCK-BOOST TRANSFORMERS INSIDE OF TOWER MOUNTED, SS, NEMA 4X JUNCTION BOXES. SEE DRAWING RL4-4, NOTE 6 FOR TYPICAL BUCK-BOOST TRANSFORMER INFORMATION.
- UNDERPASS LIGHTING UNITS WIRED WITH 3#10 AND 1#10 GND IN 1" PVCC RGC FROM UNIT TO UNIT. SEE DRAWING UL-1 FOR TYPICAL UNDERPASS LIGHTING UNIT WIRING DIAGRAM.
- AMPS COLUMN INCLUDES ADDITIONAL AMPERAGE ON PRIMARY SIDE OF BUCK-BOOST TRANSFORMERS.
- SEE IDOT STANDARD DRAWING BE-505c FOR HIGH MAST POLE WIRING DIAGRAM.
- CKTS E&F: 3#2 & 1#4 GND, ECA.

LEGEND:

- PROPOSED HIGH MAST LIGHT TOWER
750W HPS LUMINAIRE (TYP. U.N.O.)
(BLACK PHASE - SOLID SYMBOLS,
RED PHASE - OPEN SYMBOLS)
- 12 120FT
13 130FT
- HIGH MAST TOWER DESIGNATION
- PROPOSED UNDERPASS LIGHTING UNIT
70W HPS LUMINAIRE (TYP. U.N.O.)
(BLACK PHASE - SOLID SYMBOLS,
RED PHASE - OPEN SYMBOLS)
- LIGHTING CONTROLLER
- GROUND FIELD
- ELECTRIC UTILITY SERVICE DROP
- BUCK-BOOST TRANSFORMER ENCLOSURE

LOAD TABULATION IS BASED ON THE FOLLOWING:

750W HPS (HMT) LUMINAIRE: 3.5A AT 240V
70W HPS UNDERPASS LUMINAIRE: 0.43A AT 240V
** SEE NOTE 5

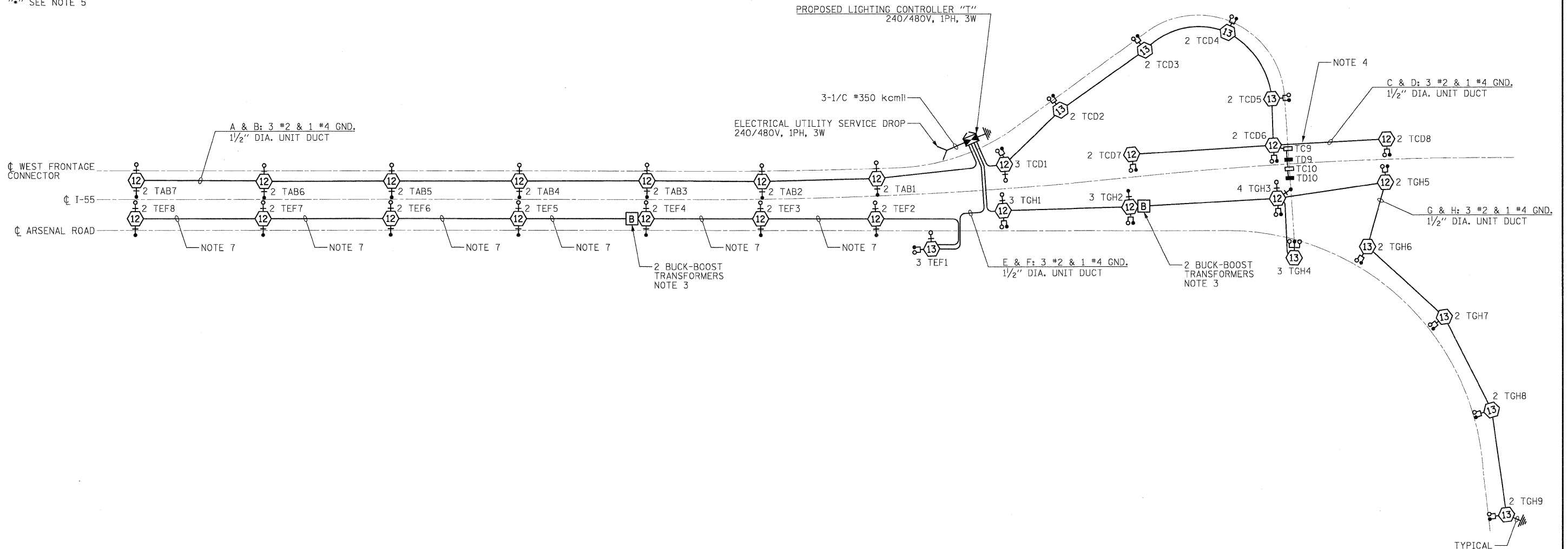

FILE NAME = D168F12-SHT-EW-2.dgn	USER NAME = TK1uegal	DESIGNED - JLW	REVISED -
		DRAWN - CJM	REVISED -
		CHECKED - KMY	REVISED -
		DATE - 2/4/11	REVISED -

STATE OF ILLINOIS
DEPARTMENT OF TRANSPORTATION

I-55 AT ARSENAL ROAD
PROPOSED LIGHTING CONTROLLER "T"
FINAL CONDITIONS SINGLE LINE DIAGRAM

SCALE: NONE SHEET NO. 1 OF 1 SHEETS STA. TO STA.

F.A.I. RTE. 55	SECTION 99-21B-2B-1	COUNTY WILL	TOTAL SHEETS 756	SHEET NO. 415
FED. ROAD DIST. NO. 1 ILLINOIS FED. AID PROJECT			CONTRACT NO. 60F12	

NOTES:

1. SEE DRAWING GE-1 FOR ELECTRICAL SYMBOL LIST AND ABBREVIATIONS. SEE DRAWING GE-2 FOR ELECTRICAL GENERAL NOTES AND SUGGESTED LIGHTING PHASING NOTES.
2. SEE DRAWING S-1 FOR WALL MOUNTED LIGHT TOWER FOUNDATION DETAILS.

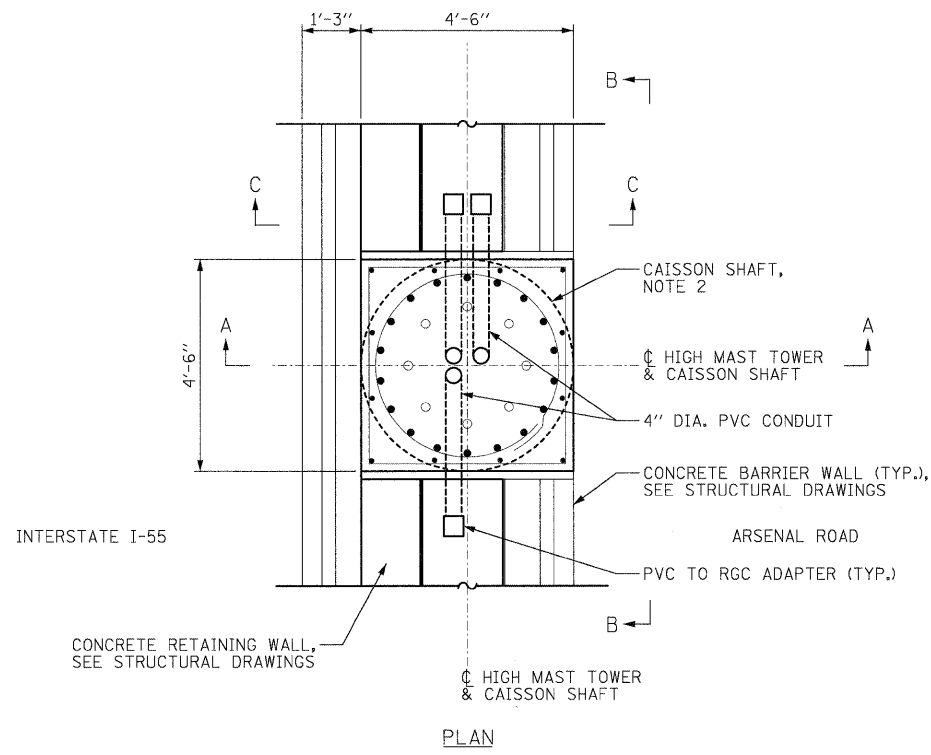

PLAN

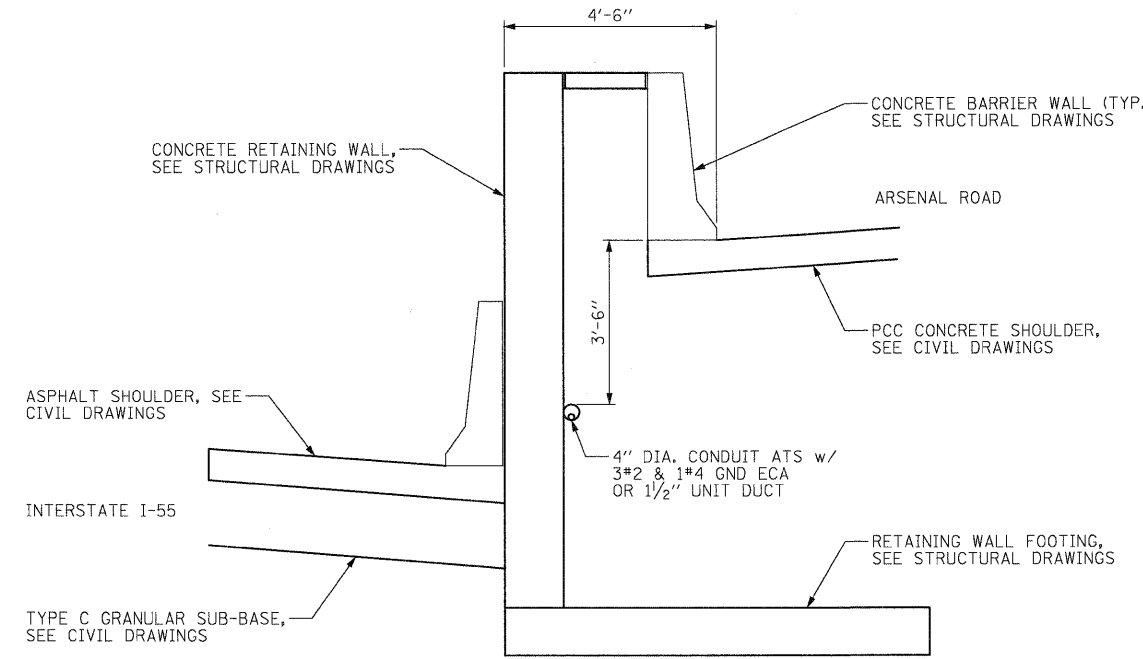

SECTION C-C

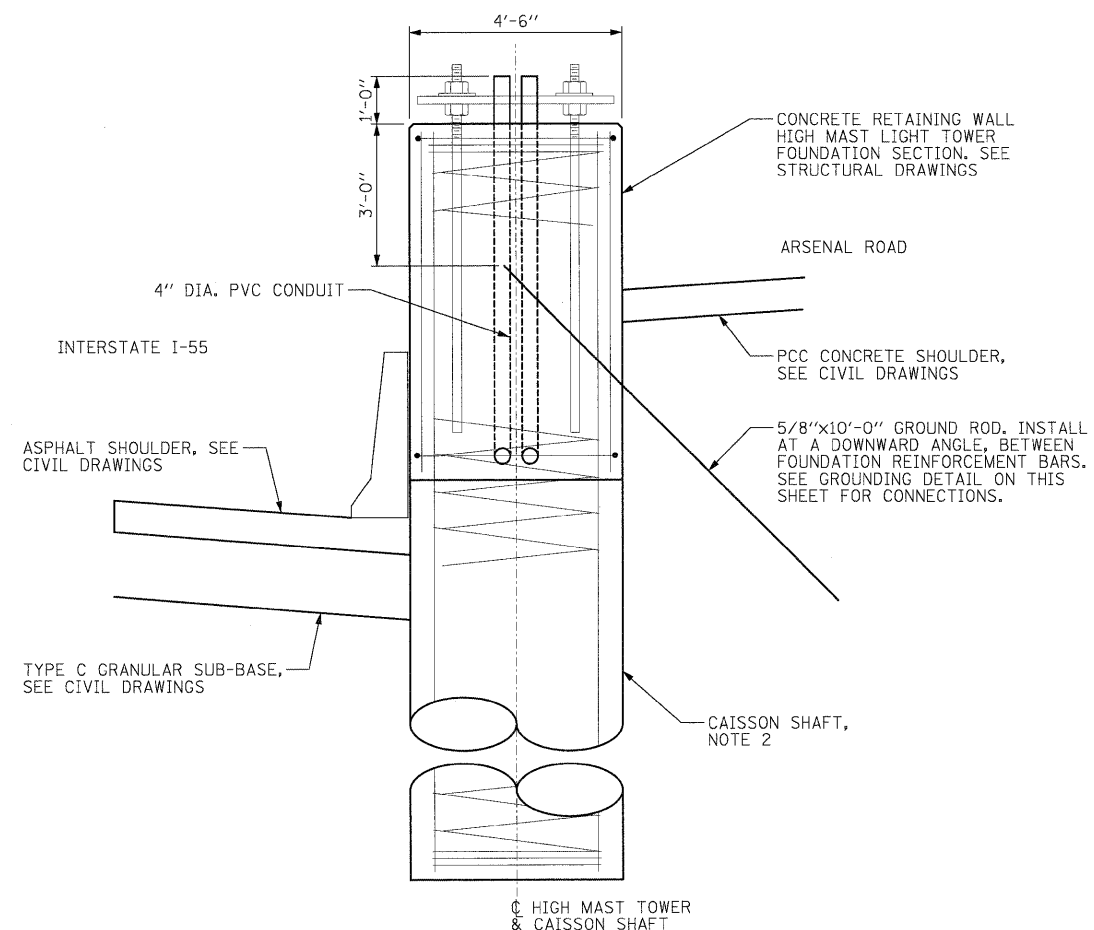

SECTION A-A

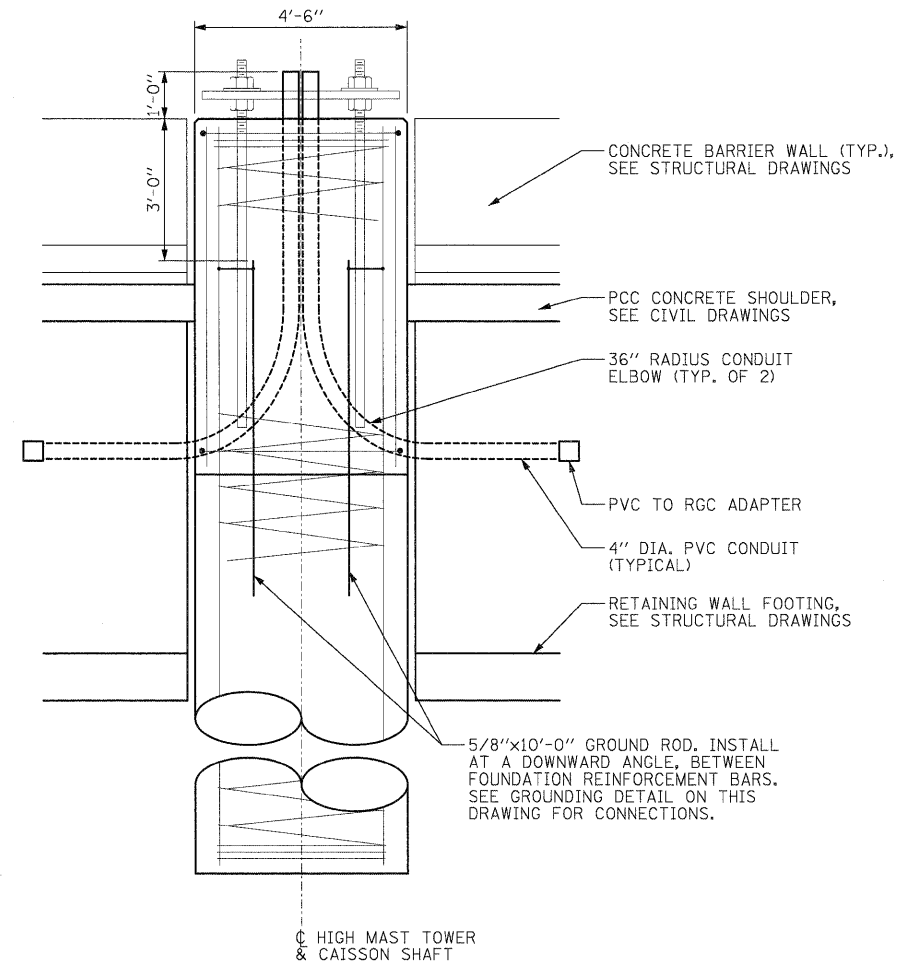

SECTION B-B

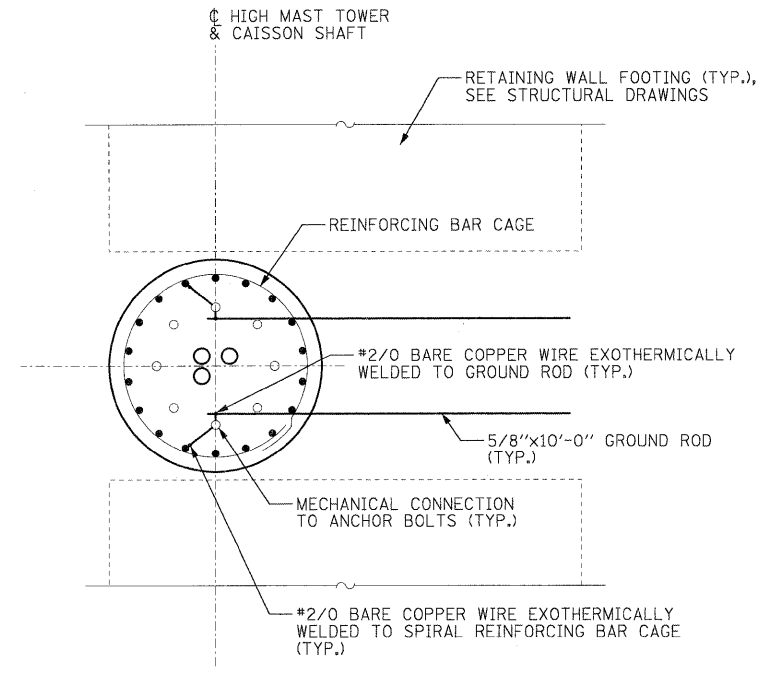

HIGH MAST TOWER GROUNDING DETAIL
N.T.S.

HIGH MAST TOWER FOUNDATION AT RETAINING WALL DETAIL
N.T.S.

McDonough Associates Inc.
 Engineers / Architects
 130 East Randolph Street, Chicago, Illinois 60601

FILE NAME =	USER NAME = TKLuegel
D:\60F12-SHT-ED-1.dgn	
PLOT SCALE = 1:1	
PLOT DATE = 2/3/2011	

DESIGNED - JLW	REVISED -
DRAWN - CJM	REVISED -
CHECKED - KMY	REVISED -
DATE - 2/4/11	REVISED -

**STATE OF ILLINOIS
DEPARTMENT OF TRANSPORTATION**

**I-55 AT ARSENAL ROAD
CONDUIT INSTALLATION DETAILS FOR LIGHT TOWER
FOUNDATIONS MOUNTED ON RETAINING WALLS**

F.A.I. RTE.	SECTION	COUNTY	TOTAL SHEETS	SHEET NO.
55	99-2HB-2B-1	WILL	756	416
CONTRACT NO. 60F12				
FED. ROAD DIST. NO. 1 ILLINOIS FED. AID PROJECT				

SCALE: SHEET NO. 1 OF 1 SHEETS STA. TO STA.

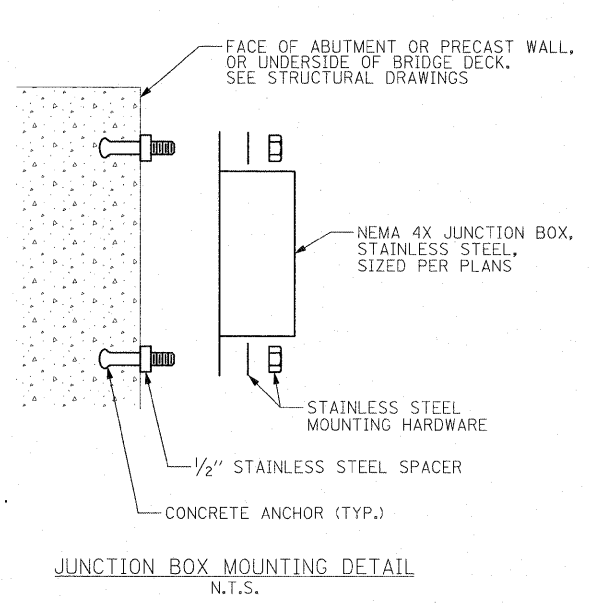
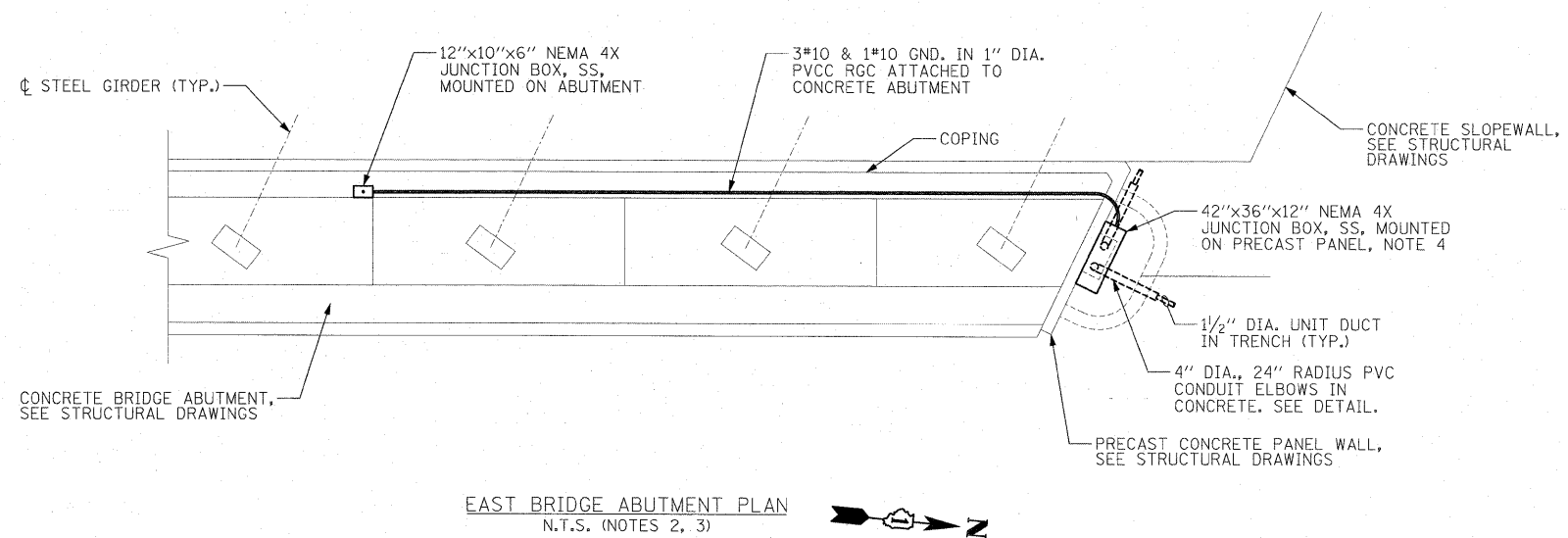

- NOTES:**
- SEE DRAWING GE-1 FOR ELECTRICAL SYMBOL LIST AND ABBREVIATIONS. SEE DRAWING GE-2 FOR ELECTRICAL GENERAL NOTES AND SUGGESTED LIGHTING PHASING NOTES.
 - SEE DRAWINGS RL3-3 AND UL-1 FOR LIGHTING FIXTURES, JUNCTION BOXES, AND UNIT DUCT ROUTING AT RAMP C. SEE IDOT STANDARD DRAWING BE-900 FOR FIXTURE MOUNTING DETAILS.
 - SEE STRUCTURAL DRAWINGS SC-1 THRU SC-37 FOR RAMP C BRIDGE CONCRETE ABUTMENT AND DECK FRAMING DETAILS. SEE DRAWING GP-3 (VOLUME 1) FOR FINAL GRADING AT RAMP C BRIDGE.
 - JUNCTION BOX CONTAINS 30A FUSES AND SOLID SLUG FOR NEUTRAL CONDUCTOR. SEE DRAWING UL-1 FOR TYPICAL UNDERPASS LIGHTING UNIT WIRING DIAGRAM.
 - THE COST OF 4" DIA. PVCC RGC, ATS AND CONCRETE ENCASEMENT SHALL BE INCLUDED IN THE COST OF "JUNCTION BOX, STAINLESS STEEL, ATTACHED TO STRUCTURE, 42"x36"x12" PAY ITEM. SEPARATE PAYMENT WILL NOT BE MADE.

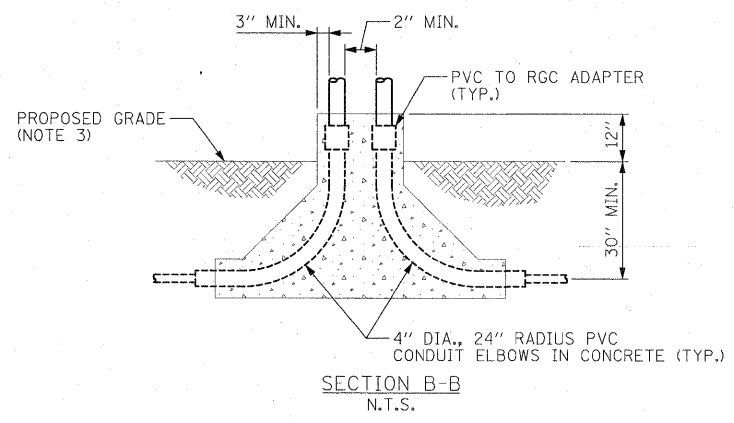
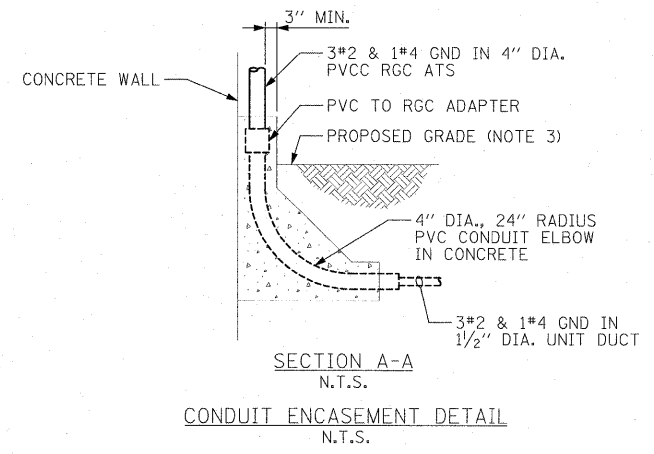
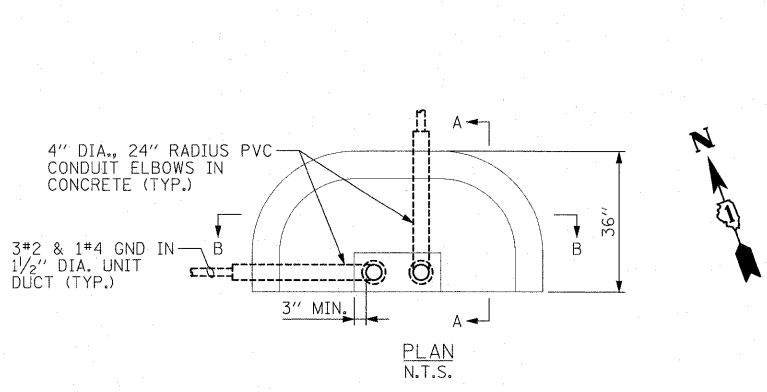
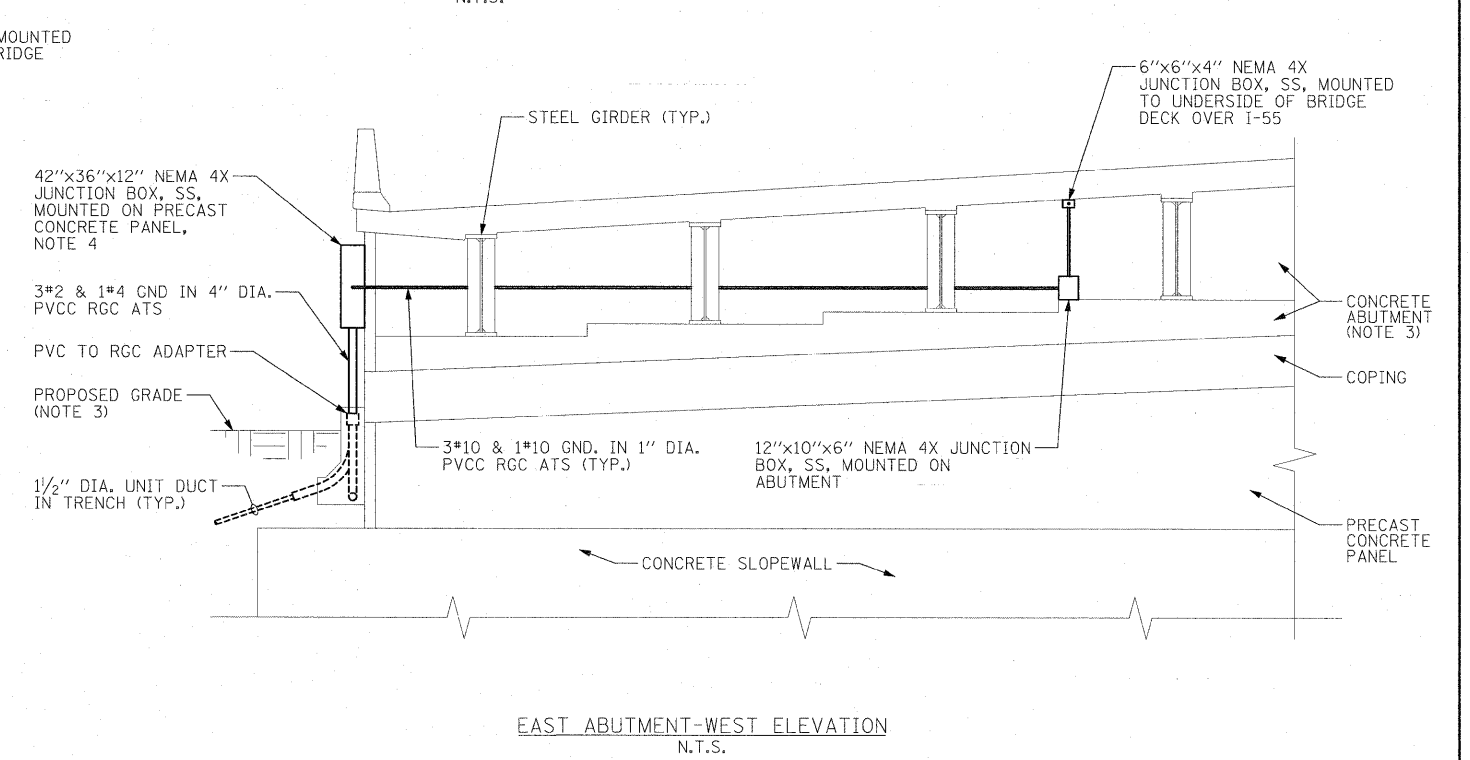
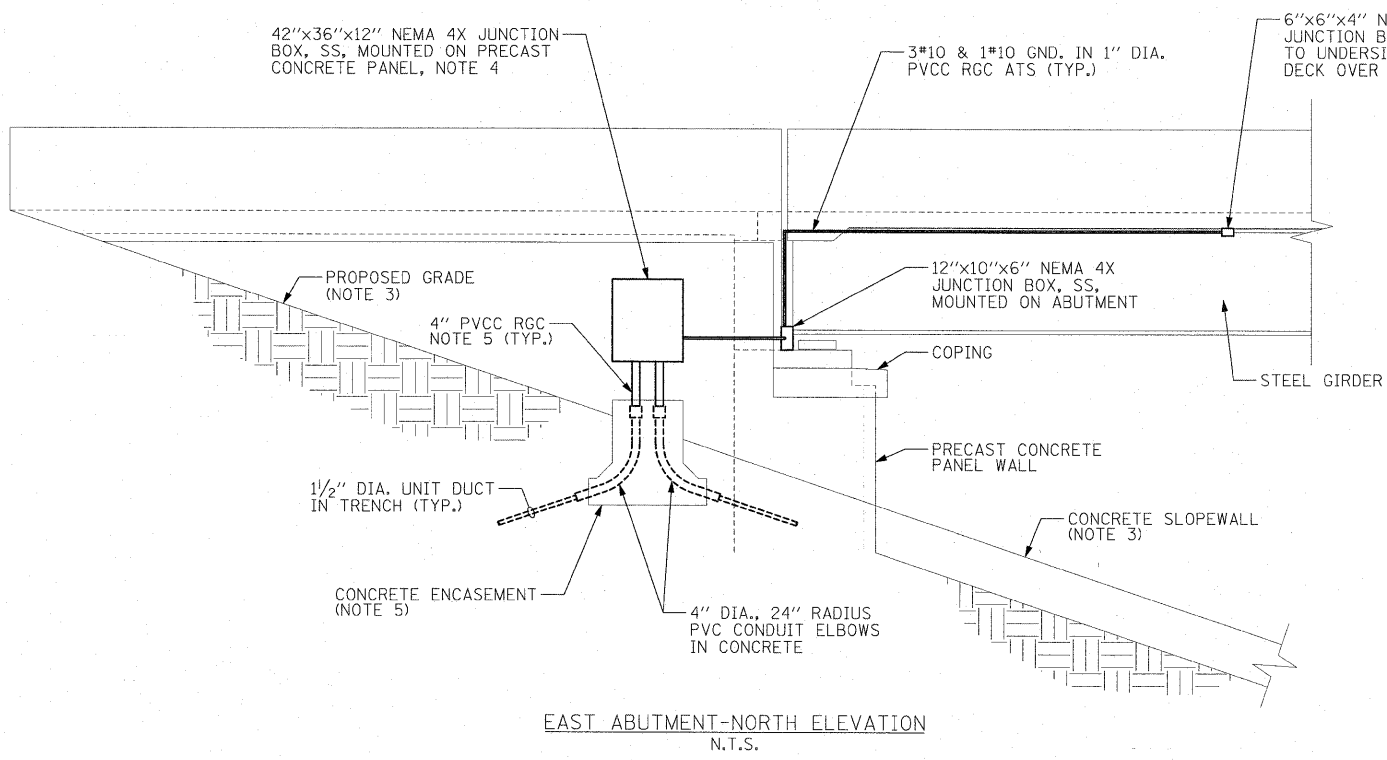

McDonough Associates Inc.
Engineers / Architects
130 East Randolph Street Chicago, Illinois 60601

FILE NAME = D:\60F12-SHT-ED-3.dgn	USER NAME = TKluagel	DESIGNED - JLW	REVISED -
PLDT SCALE = 1:1		DRAWN - CJM	REVISED -
PLDT DATE = 3/7/2011		CHECKED - KMY	REVISED -
		DATE - 2/4/11	REVISED -

STATE OF ILLINOIS
DEPARTMENT OF TRANSPORTATION

I-55 AT ARSENAL ROAD
RAMP C BRIDGE CONDUIT INSTALLATION DETAILS

F.A.I. RTE.	SECTION	COUNTY	TOTAL SHEETS	SHEET NO.
55	99-2HB-2B-1	WILL	756	418
CONTRACT NO. 60F12				
FED. ROAD DIST. NO. 1 ILLINOIS FED. AID PROJECT				

SCALE: SHEET NO. 1 OF 1 SHEET STA. TO STA.

NOTES:

- SEE DRAWING GE-1 FOR ELECTRICAL SYMBOL LIST AND ABBREVIATIONS. SEE DRAWING GE-2 FOR ELECTRICAL GENERAL NOTES AND SUGGESTED LIGHTING PHASING NOTES.
- SEE DRAWINGS RL-4-7 AND UL-2 FOR LIGHTING FIXTURES, JUNCTION BOXES, AND UNIT DUCT ROUTING AT WEST FRONTAGE CONNECTOR BRIDGE. SEE IDOT STANDARD DRAWING BE-900 FOR FIXTURE MOUNTING DETAILS.
- SEE STRUCTURAL DRAWINGS SF1 THRU SF24 FOR WEST FRONTAGE CONNECTOR BRIDGE CONCRETE ABUTMENT, PIER, AND DECK BEAM DETAILS. SEE DRAWING GP-13 (VOLUME 1) FOR FINAL GRADING AT WEST FRONTAGE CONNECTOR BRIDGE.
- JUNCTION BOX CONTAINS 30A FUSES AND SOLID SLUG FOR NEUTRAL CONDUCTOR. SEE DRAWING UL-1 FOR TYPICAL UNDERPASS LIGHTING UNIT WIRING DIAGRAM.
- SEE DRAWING ED-3 FOR JUNCTION BOX MOUNTING DETAIL.
- THE COST OF 4" DIA. PVCC RGC, ATS AND CONCRETE ENCASUREMENT SHALL BE INCLUDED IN THE COST OF "JUNCTION BOX, STAINLESS STEEL, ATTACHED TO STRUCTURE, 42"x36"x12" PAY ITEM. SEPARATE PAYMENT WILL NOT BE MADE.

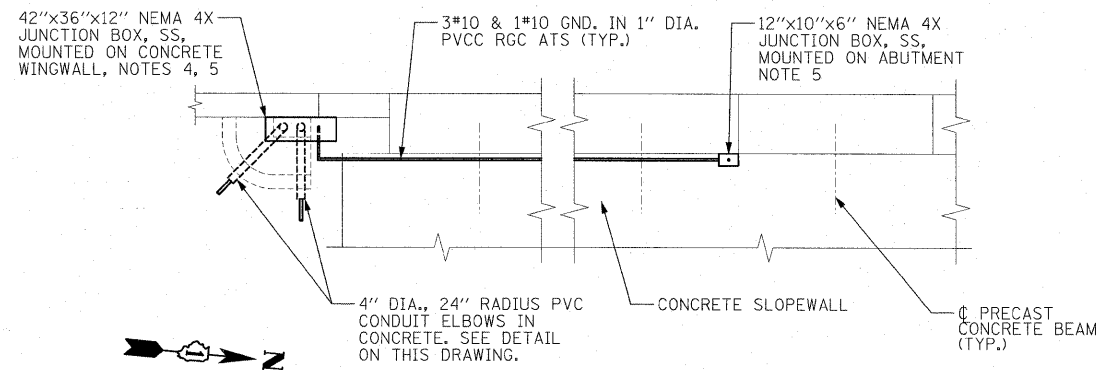

WEST BRIDGE ABUTMENT PLAN
N.T.S. (NOTES 2, 3)

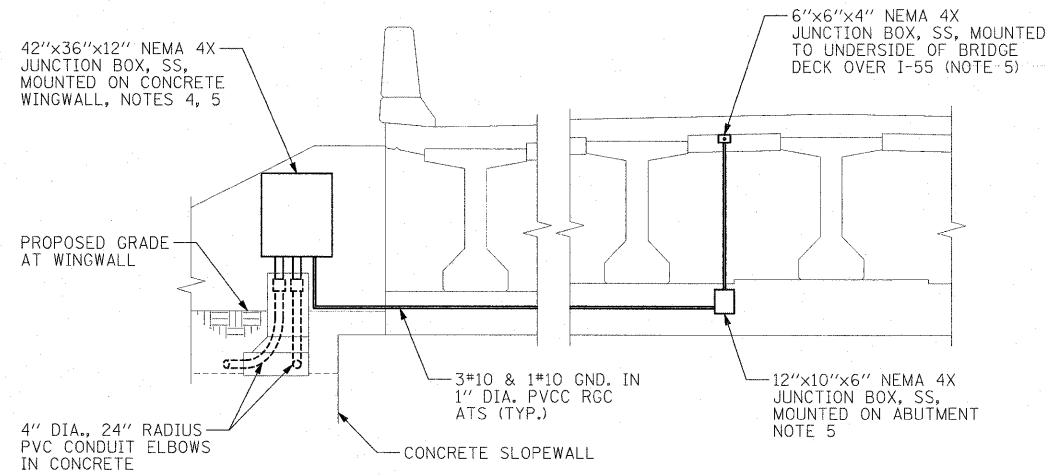

WEST ABUTMENT-EAST ELEVATION
N.T.S.

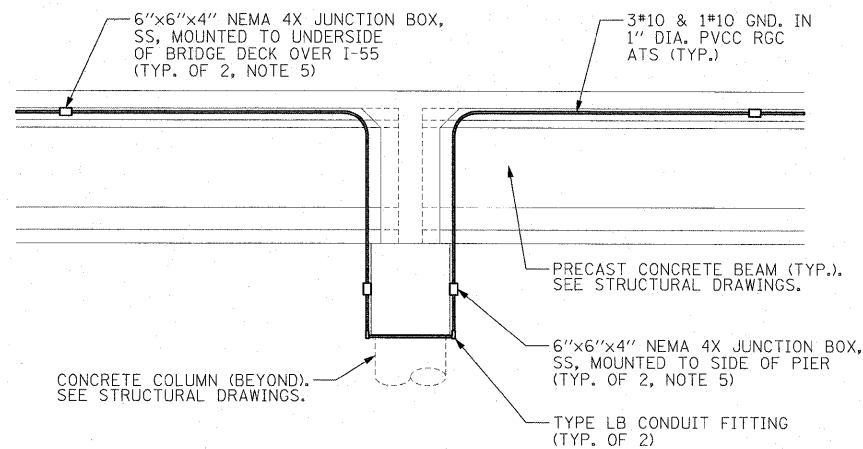

CENTER PIER-SECTION
(LOOKING SOUTH)
N.T.S.

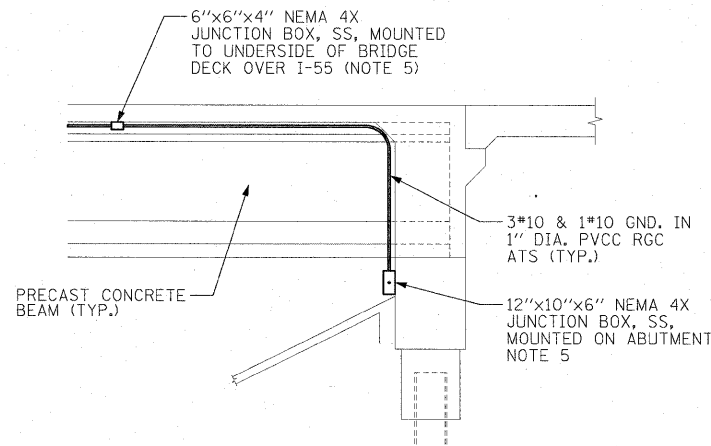

WEST ABUTMENT-SECTION
(LOOKING SOUTH)
N.T.S.

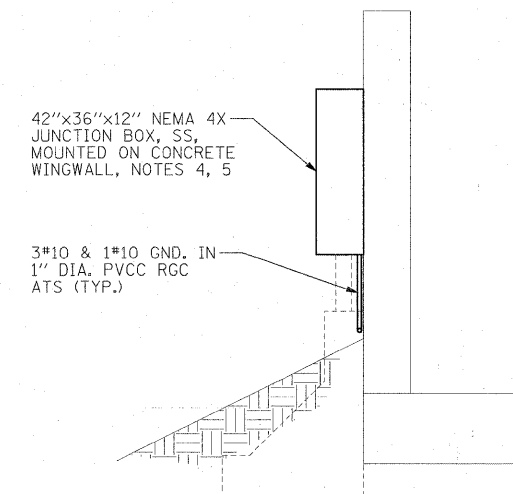

WEST ABUTMENT WINGWALL SECTION
(LOOKING SOUTH)
N.T.S.

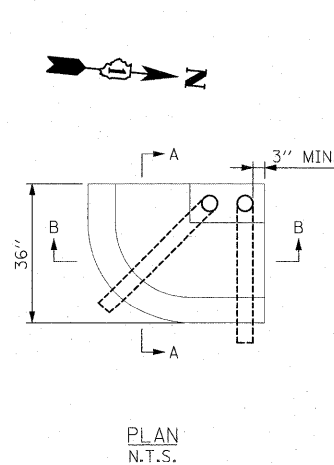

PLAN
N.T.S.

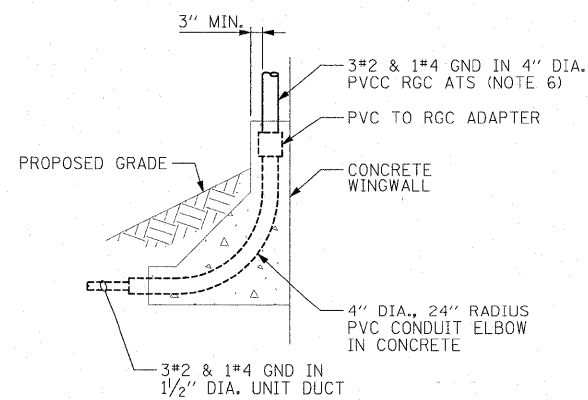

SECTION A-A
N.T.S.

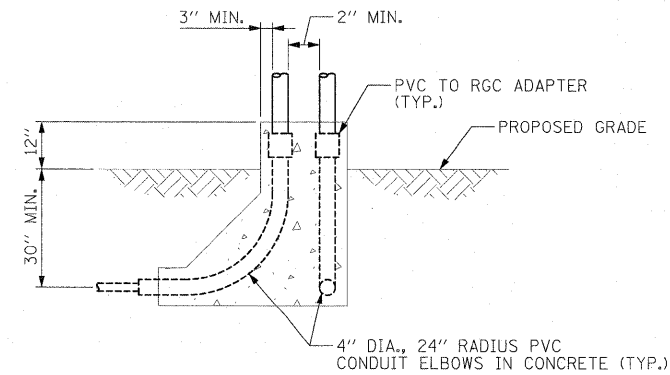

SECTION B-B
N.T.S.

CONDUIT ENCASUREMENT DETAIL
N.T.S.

FILE NAME = D160F12-SHT-ED-4.dgn	USER NAME = TK1uegel	DESIGNED - JLW	REVISED -
		DRAWN - CJM	REVISED -
		CHECKED - KMY	REVISED -
		DATE - 2/4/11	REVISED -

F.A.I. RTE.	SECTION	COUNTY	TOTAL SHEETS	SHEET NO.
55	99-2HB-2B-1	WILL	756	419
CONTRACT NO. 60F12			ILLINOIS FED. AID PROJECT	

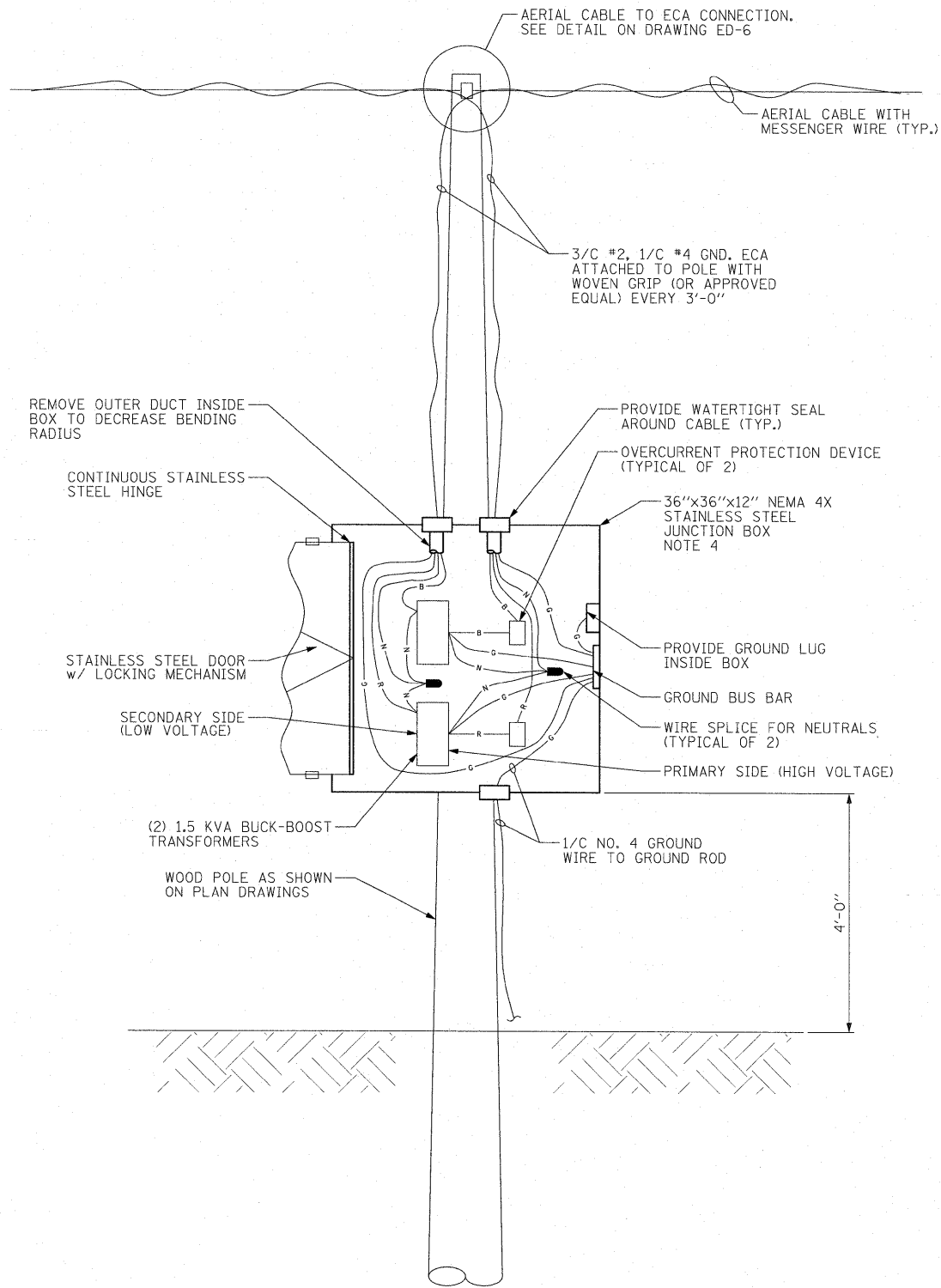

TEMPORARY WOOD POLE MOUNTED
 BUCK-BOOST TRANSFORMER INSTALLATION DETAIL
 N.T.S.

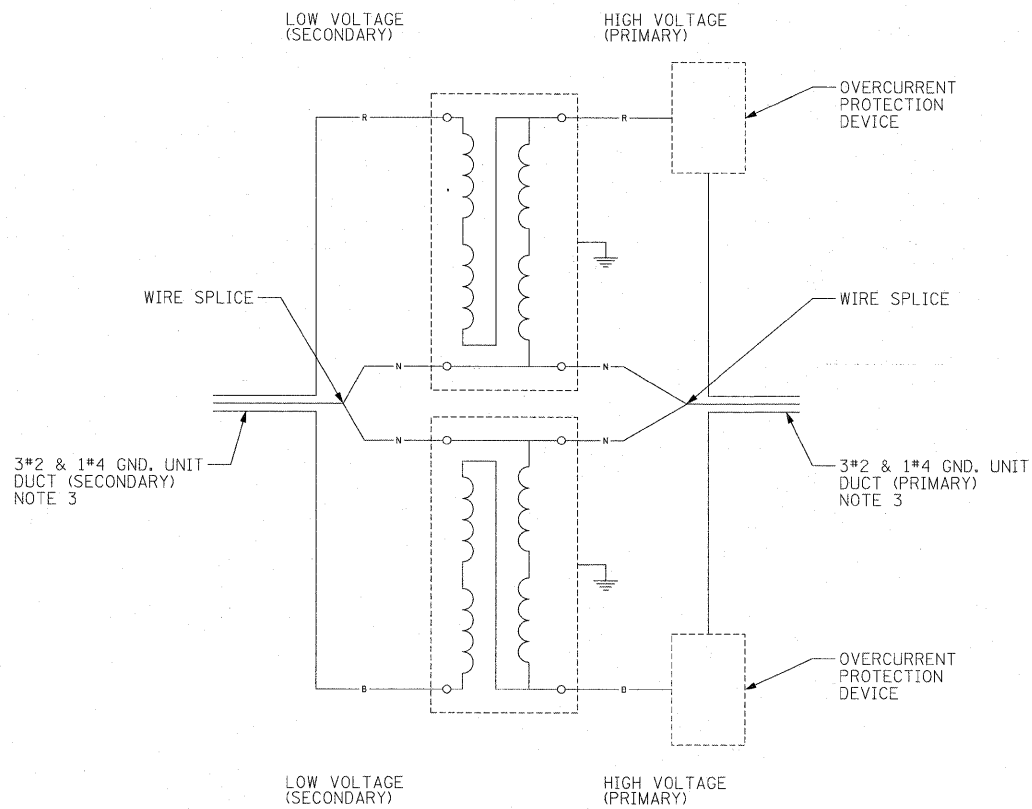

TYPICAL BUCK BOOST TRANSFORMER WIRING DIAGRAM
 N.T.S. (NOTE 2)

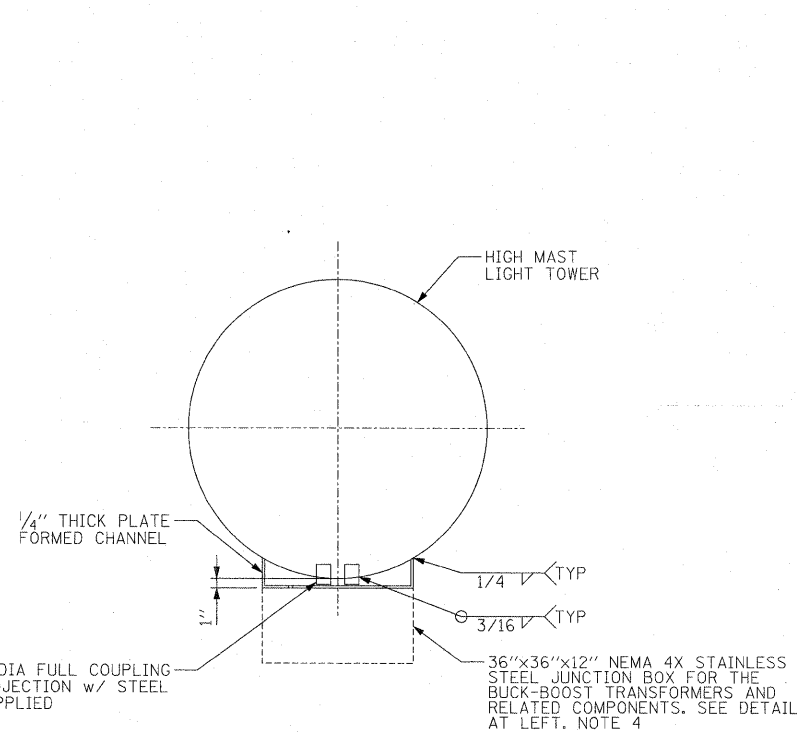

PLAN

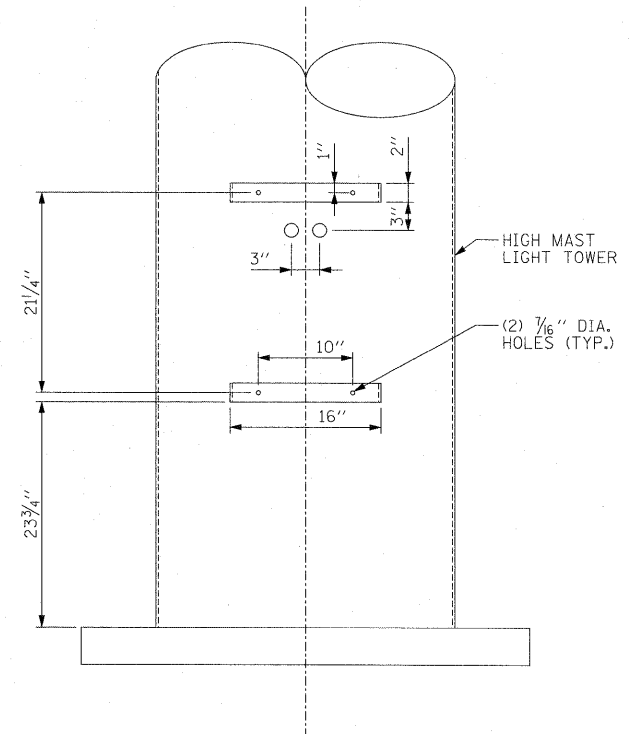

ELEVATION

TOWER MOUNTED PERMANENT JUNCTION BOX/
 BUCK-BOOST TRANSFORMER INSTALLATION DETAIL
 N.T.S.

NOTES:

- SEE DRAWING GE-1 FOR ELECTRICAL SYMBOL LIST AND ABBREVIATIONS. SEE DRAWING GE-2 FOR ELECTRICAL GENERAL NOTES AND SUGGESTED LIGHTING PHASING NOTES.
- THE CONTRACTOR SHALL CONNECT THE TRANSFORMER WINDINGS ACCORDING TO TRANSFORMER MANUFACTURER'S WIRING DIAGRAM FOR VOLTAGE BOOST AT THE COIL VOLTAGES SPECIFIED.
- GROUND WIRE IS NOT SHOWN FOR CLARITY BUT IT IS REQUIRED. SEE DETAIL AT LEFT FOR BUCK-BOOST TRANSFORMER CONNECTION AND WIRING INFORMATION.
- STAINLESS STEEL JUNCTION BOX ENCLOSURE SHALL BE INCLUDED IN "BUCK-BOOST TRANSFORMER, 1.5 KVA, 240V PRIMARY, 24V SECONDARY" PAY ITEM. SEPARATE PAYMENT WILL NOT BE MADE.

FILE NAME =	USER NAME = TKIuegal	DESIGNED - JLW	REVISED -
D160F12-SHT-ED-5.dgn		DRAWN - CJM	REVISED -
		CHECKED - KMY	REVISED -
		DATE - 2/4/11	REVISED -

PLOT SCALE = 1:1	
PLOT DATE = 3/7/2011	

STATE OF ILLINOIS
 DEPARTMENT OF TRANSPORTATION

I-55 AT ARSENAL ROAD
 BUCK BOOST TRANSFORMER INSTALLATION DETAILS

SCALE: SHEET NO. 1 OF 1 SHEETS STA. TO STA.

F.A.I. RTE.	SECTION	COUNTY	TOTAL SHEETS	SHEET NO.
55	99-2HB-2B-1	WILL	756	420
CONTRACT NO. 60F12				
FED. ROAD DIST. NO. 1 ILLINOIS FED. AID PROJECT				

NOTES:

- SEE DRAWING GE-1 FOR ELECTRICAL SYMBOL LIST AND ABBREVIATIONS. SEE DRAWING GE-2 FOR ELECTRICAL GENERAL NOTES AND SUGGESTED LIGHTING PHASING NOTES.
- LUMINAIRE, SODIUM VAPOR, HIGH MAST, HORIZONTAL MOUNT, 750W.
- PROVIDE TWO OR THREE LUMINAIRES WITH BULLHORN BRACKETS WHERE INDICATED ON PLANS. SEE DRAWING ED-7 FOR BULLHORN FIXTURE MOUNTING DETAILS, THE COST OF BULLHORN BRACKET SHALL BE INCLUDED IN THE COST OF WOOD LIGHT POLE PAY ITEM. SEPARATE PAYMENT WILL NOT BE MADE.
- THE COST OF CLASS SI CONCRETE, GROUND ROD, AND #6 COPPER GROUND WIRE SHALL BE INCLUDED IN THE COST OF "LIGHT POLE, WOOD, 100 FOOT, CLASS 1, WITH 15FT MAST ARM" PAY ITEM. SEPARATE PAYMENT WILL NOT BE MADE.
- SEE IDOT STANDARD DRAWINGS BE-800 AND BE-801 FOR ADDITIONAL TEMPORARY LIGHT POLE AND TEMPORARY AERIAL CABLE INSTALLATION DETAILS.
- PROVIDE 5/8" X 10'-0" GROUND ROD FOR EVERY THIRD WOOD POLE.

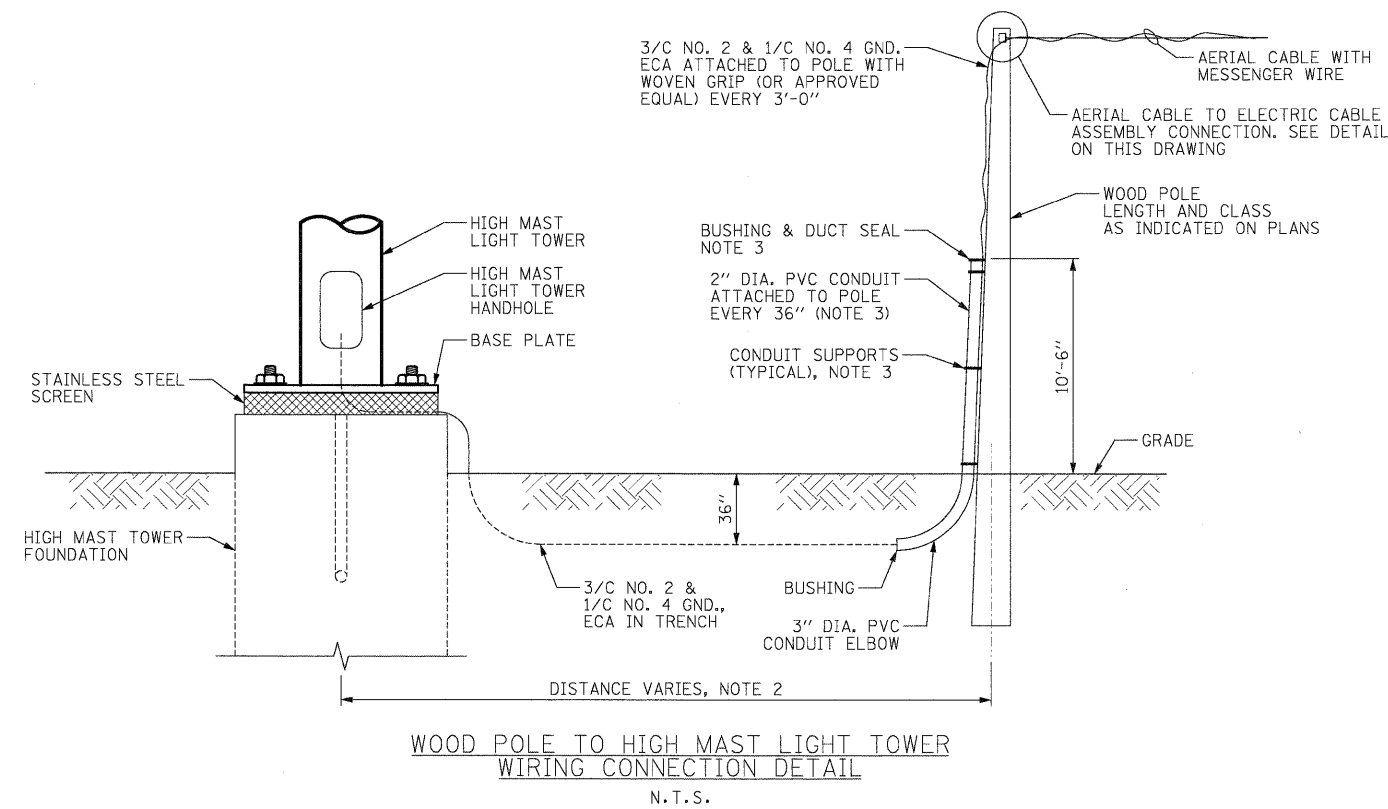

WOOD POLE TO HIGH MAST LIGHT TOWER WIRING CONNECTION DETAIL

N.T.S.

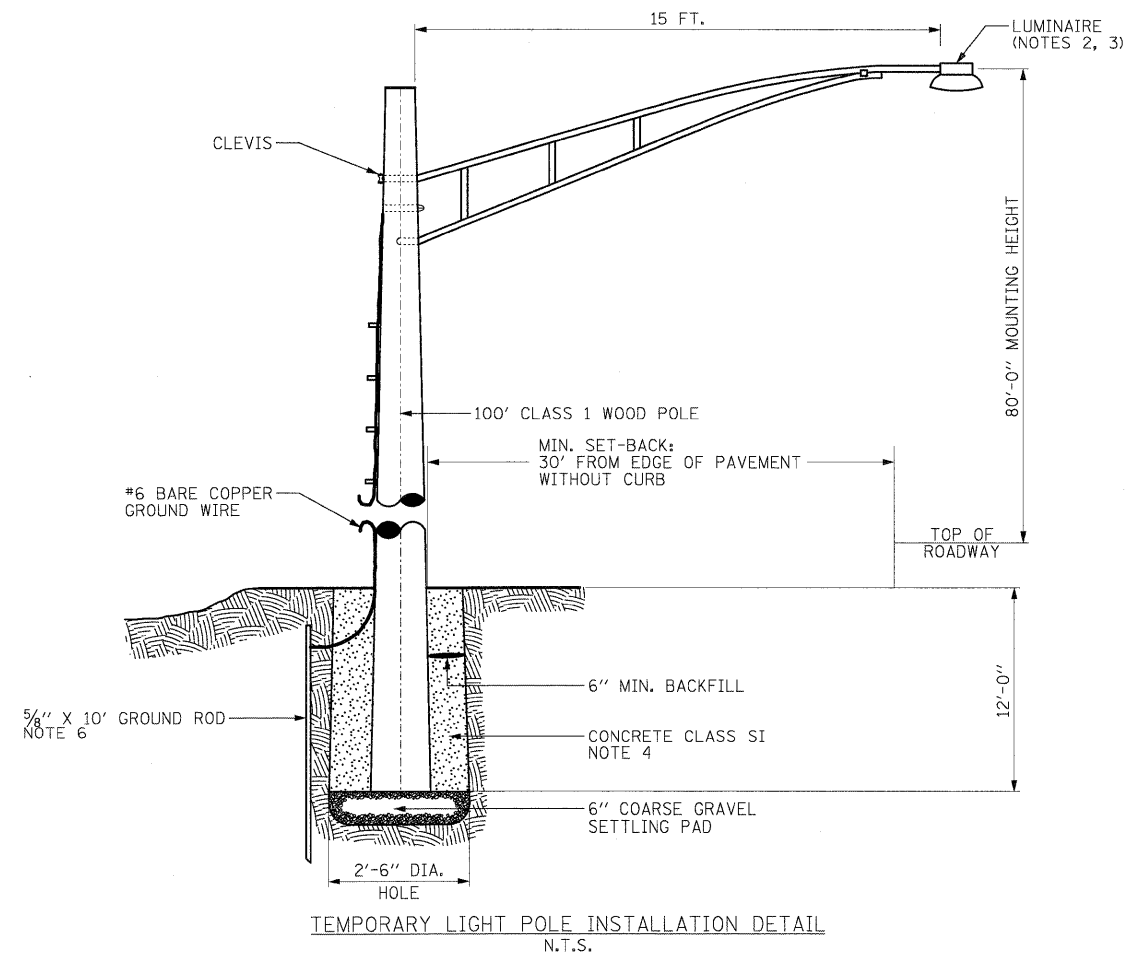

TEMPORARY LIGHT POLE INSTALLATION DETAIL

N.T.S.

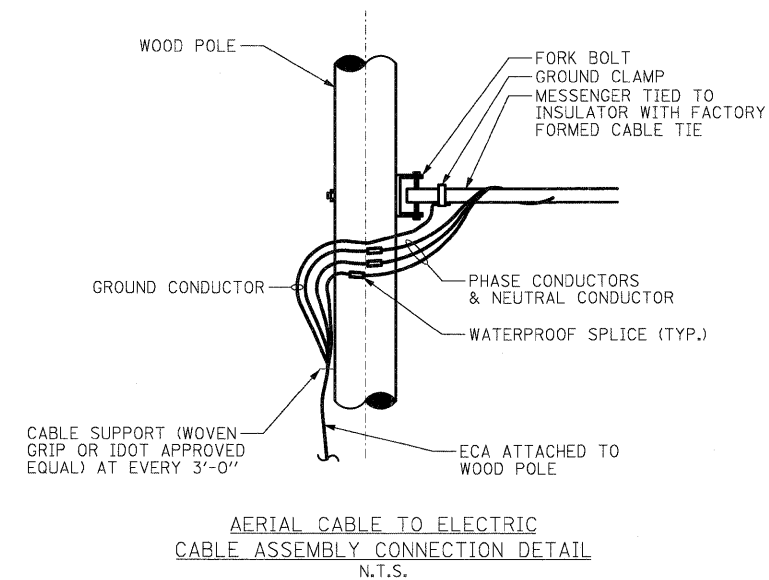

AERIAL CABLE TO ELECTRIC CABLE ASSEMBLY CONNECTION DETAIL

N.T.S.

FILE NAME =	USER NAME = TKJuegal
D:\160\F12-SHT-ED-6.dgn	
PLOT SCALE = 1:1	
PLOT DATE = 2/3/2011	

DESIGNED - JLW	REVISED -
DRAWN - CJM	REVISED -
CHECKED - KMY	REVISED -
DATE - 2/4/11	REVISED -

**STATE OF ILLINOIS
DEPARTMENT OF TRANSPORTATION**

**I-55 AT ARSENAL ROAD
TEMPORARY LIGHTING DETAILS 1 OF 2**

SCALE: SHEET NO. 1 OF 2 SHEETS STA. TO STA.

F.A.I. RTE.	SECTION	COUNTY	TOTAL SHEETS	SHEET NO.
55	99-2HB-2B-1	WILL	756	421
CONTRACT NO. 60F12			ILLINOIS FED. AID PROJECT	

NOTES:

- SEE DRAWING GE-1 FOR ELECTRICAL SYMBOL LIST AND ABBREVIATIONS. SEE DRAWING GE-2 FOR ELECTRICAL GENERAL NOTES AND SUGGESTED LIGHTING PHASING NOTES.
- LUMINAIRE SHALL BE HORIZONTAL MOUNTED 750W HPS, HIGH MAST LUMINAIRE.

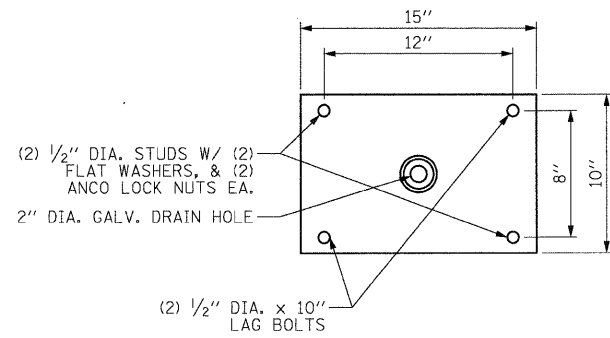
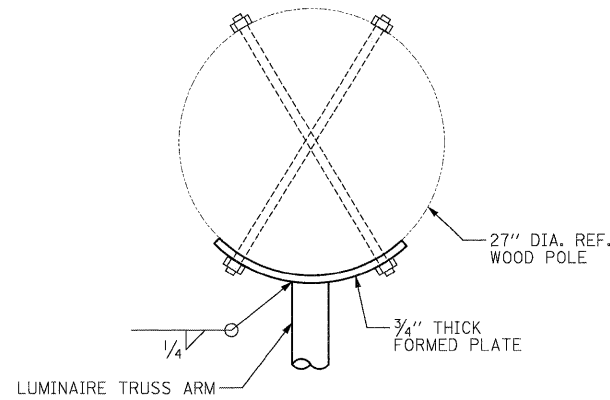
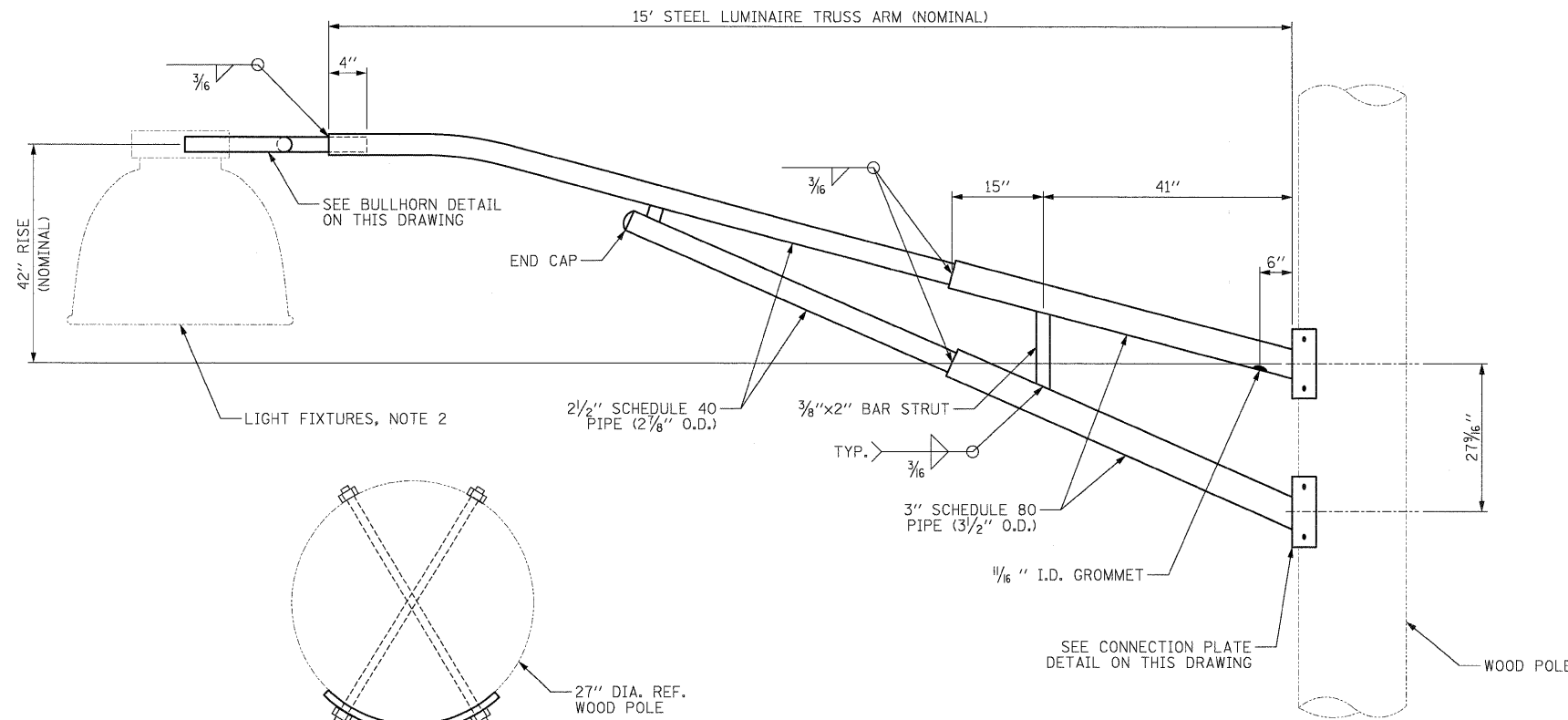

LUMINAIRE TRUSS ARM CONNECTION PLATE DETAIL
N.T.S.

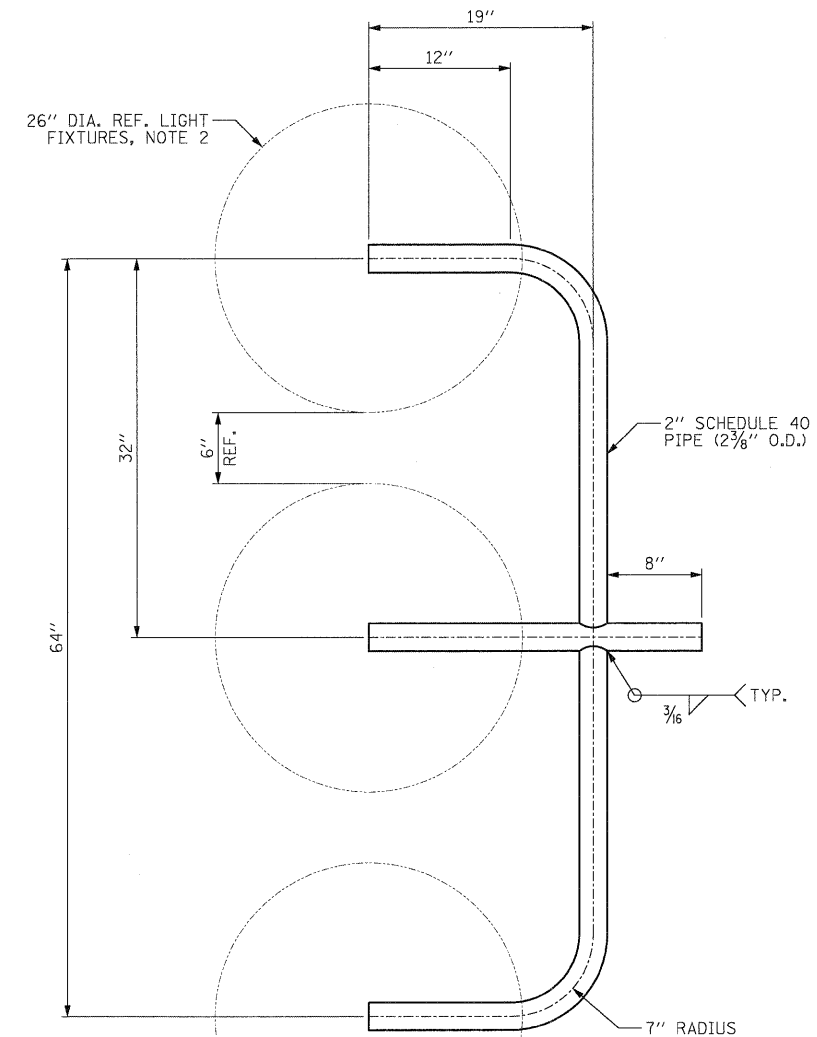

BULLHORN DETAIL
N.T.S.

DESIGN CRITERIA:

- DESIGNED IN ACCORDANCE WITH 1994 AASHTO "STANDARD SPECIFICATIONS FOR STRUCTURAL SUPPORTS FOR HIGHWAY SIGNS, LUMINAIRES, AND TRAFFIC SIGNALS" FOR 90 MILE PER HOUR WIND ZONE.
- CONTRACTOR TO CONFIRM ALL DIMENSIONS & ORIENTATIONS BEFORE RELEASING ORDER FOR MANUFACTURING.

MATERIALS	
PIPE	ASTM A501 or A53 GRADE B
PLATE	ASTM A36
LUM ARM STUDS	ASTM A307
ANCO LOCK NUTS	ASTM A563 GRADE DH
WASHERS	ASTM F436
STRUCTURE FINISH	PER SALES ORDER
HARDWARE FINISH	HD GALV TO ASTM A153

FILE NAME = D:\80F12-SHT-ED-7.dgn	USER NAME = TKLuegel	DESIGNED -	REVISED -	STATE OF ILLINOIS DEPARTMENT OF TRANSPORTATION	I-55 AT ARSENAL ROAD TEMPORARY LIGHTING DETAILS 2 OF 2			F.A.I R.T.E. 55	SECTION 99-2HB-2B-1	COUNTY WILL	TOTAL SHEETS 756	SHEET NO. 422
PLLOT SCALE = 1:1	CHECKED - KMY	REVISED -	REVISED -		SCALE:	SHEET NO. 2 OF 2 SHEETS	STA.	TO STA.	CONTRACT NO. 60F12			
PLLOT DATE = 2/3/2011	DATE - 2/4/11	REVISED -	REVISED -		FED. ROAD DIST. NO. 1 ILLINOIS FED. AID PROJECT							

1-PH COMPT TR PAD - ESS/RSS
167kVA MAXIMUM CAPACITY

ITEM	MATERIAL DESCRIPTION (BY ComEd)	MIG	SI	UNIT	QTY
A	GROUNDING INSTALLATION (1) C8550_G0	G			1
C	Wire, Copper, #1/0-19 Strand, Soft Drawn, Tin Coated, Bare (1)	G	355082	FT	35
D	Connector, Compression, 1/0 Or 2/0 Strd Cu. Run & Top.	U	368545	EA	1

- NOTES:**
- APPLICATION**
- THIS STANDARD SHALL BE USED FOR THE INSTALLATION OF AN ELECTRIC OR RESIDENTIAL SERVICE STATION FOUNDATION AS DESCRIBED IN THE "INFORMATION AND REQUIREMENTS FOR THE SUPPLY OF ELECTRIC SERVICE BOOK", SECTIONS 2.02 AND 2.07.
- SUPPLEMENTARY MATERIAL**
- WHEN BARE LEAD COVERED CABLES ARE LOCATED OR PLANNED WITHIN 200 FEET, OMIT ITEM "C" AND REPLACE WITH 1/0 LEAD CLAD COPPER CONDUCTOR (SI 360809). SPECIFY STAINLESS STEEL GROUNDS PER C8550.G0.
 - PRECAST ALTERNATIVES TO THIS POURED DESIGN MAY BE AVAILABLE. CONTACT CONSTRUCTION STANDARDS GROUP.
- INFORMATION**
- THE CUSTOMER TO INSTALL THE TRANSFORMER FOUNDATION, 1 INCH CONDUITS, AND TRENCH FOR ComEd GROUND WIRE.
 - ComEd TO PROVIDE AND INSTALL THE GROUND WIRE AND GRID.
 - AFTER PRIMARY AND SECONDARY CONDUITS ARE IN PLACE, BACKFILL WITH SCREENINGS, SAND, OR FINE EXCAVATED MATERIAL, COMPACT THOROUGHLY BEFORE POURING FOUNDATION.
 - CONCRETE TO BE IN ACCORDANCE WITH THE LATEST EDITION OF THE APPLICABLE ACI CODE AND AIR ENTRAINMENT. IT SHALL HAVE A MINIMUM COMPRESSIVE STRENGTH OF 3000 PSI AT 28 DAYS. AIR ENTRAINMENT SHALL BE 4 TO 7 PERCENT OF THE VOLUME OF CONCRETE.
 - TOP OF FOUNDATION TO BE SMOOTH AND LEVEL.
 - GRADE AWAY FROM FOUNDATION. FINAL GRADE SHALL BE WELL DRAINED AT ALL TIMES.
 - PRIMARY AND SECONDARY CONDUIT MUST COME THROUGH FOUNDATION IN DESIGNATED AREAS.
 - SEE C7723 FOR BURNDY-HUSKY DIE SET CROSS REFERENCE.
 - DO NOT PLACE CONDUITS UNDER THIS SECTION OF FOUNDATION IF AVOIDABLE.
 - DO NOT DISTURB EARTH IN FOUNDATION AREA MORE THAN NECESSARY WHEN INSTALLING CONDUIT.
 - TERMINATE PRIMARY AND SECONDARY CONDUITS FLUSH WITH TOP OF FOUNDATION.
 - BOX OUT CONDUIT OPENING.
 - SECONDARY CONDUIT LOCATION.
 - PRIMARY CONDUIT LOCATION.
 - PLEASE CONSULT GP 346 (SPCC) OR ENVIRONMENTAL SERVICES IF EITHER OF THE FOLLOWING EXISTS:
 - A SINGLE ABOVE GROUND TANK WITH A CAPACITY OF 660 GALLONS OR MORE.
 - MORE THAN ONE ABOVE GROUND TANK WITH TOTAL CAPACITY EQUAL TO OR EXCEEDING 1320 GALLONS.

PRESSING TABLE (18)

ITEM	TOOL & DIE	NO. OF CRIMPS
	Y-35	
D	U-O	1
	U-E	3

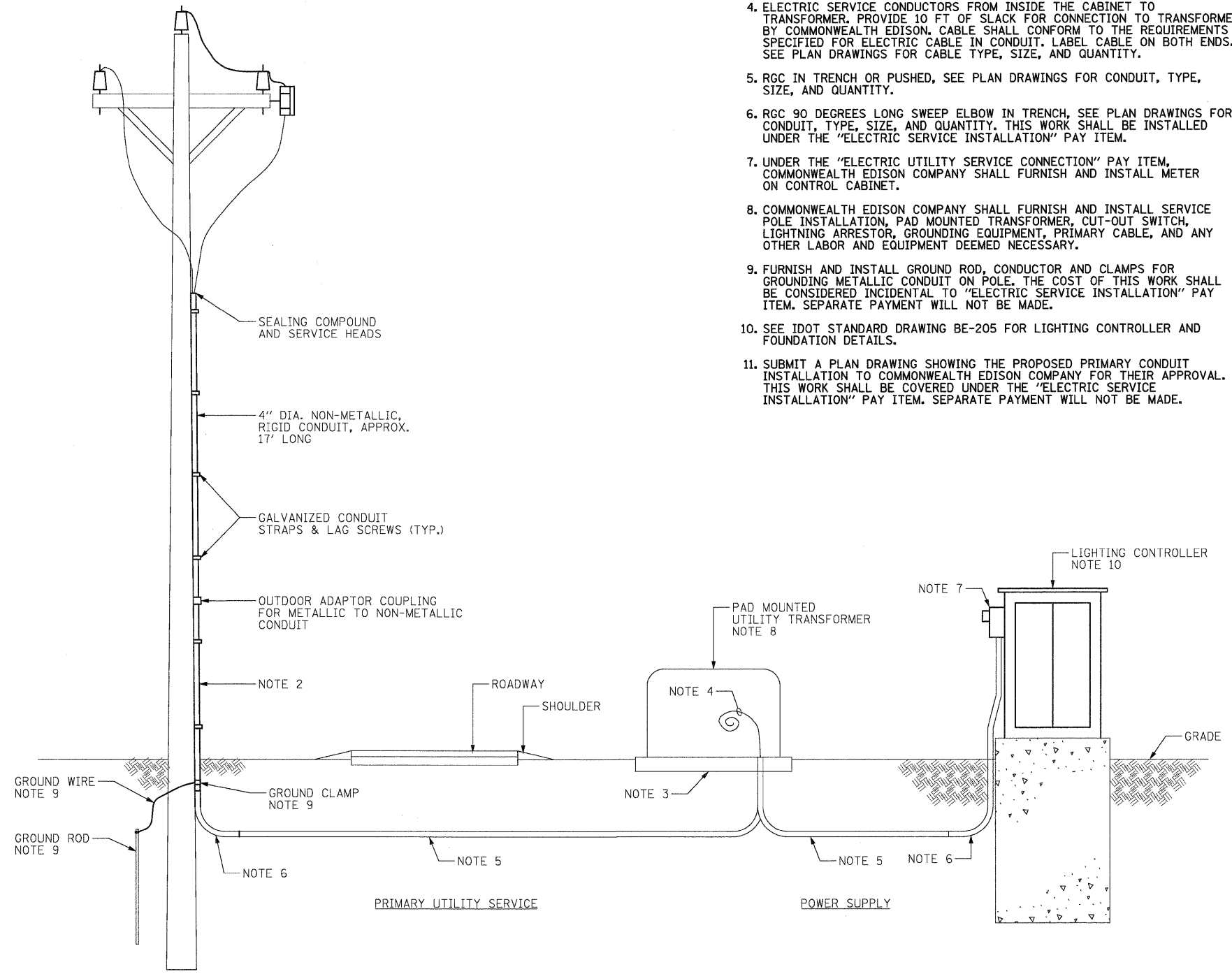
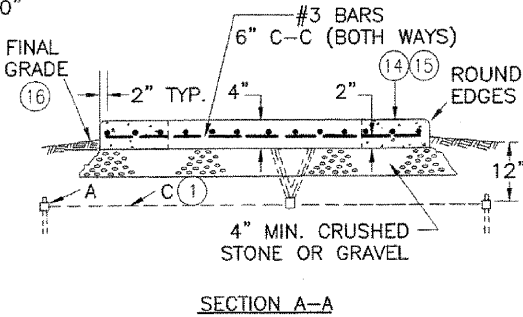
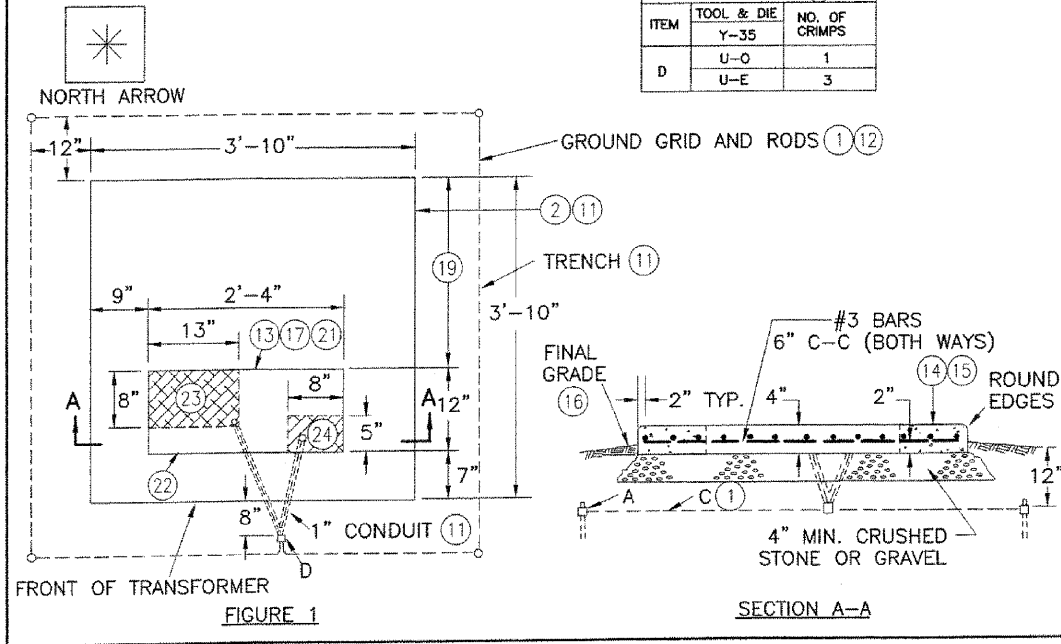

- NOTES:**
- SEE DRAWING GE-1 FOR ELECTRICAL SYMBOL LIST AND ABBREVIATIONS. SEE DRAWING GE-2 FOR ELECTRICAL GENERAL NOTES AND SUGGESTED LIGHTING PHASING NOTES.
 - THIS WORK SHALL BE INSTALLED UNDER THE "ELECTRIC SERVICE INSTALLATION" PAY ITEM.
 - COMMONWEALTH EDISON CO. SHALL FURNISH AND INSTALL THE TRANSFORMER COMPLETE WITH GROUNDING SYSTEM INCLUDING GROUND RODS, GROUNDING CONDUCTOR, PRIMARY CABLE, AND CONNECTORS. SEE COMMONWEALTH EDISON SYSTEM STANDARD C5288 FOR INSTALLATION REQUIREMENTS.
 - ELECTRIC SERVICE CONDUCTORS FROM INSIDE THE CABINET TO TRANSFORMER. PROVIDE 10 FT OF SLACK FOR CONNECTION TO TRANSFORMER BY COMMONWEALTH EDISON. CABLE SHALL CONFORM TO THE REQUIREMENTS SPECIFIED FOR ELECTRIC CABLE IN CONDUIT. LABEL CABLE ON BOTH ENDS. SEE PLAN DRAWINGS FOR CABLE TYPE, SIZE, AND QUANTITY.
 - RGC IN TRENCH OR PUSHED, SEE PLAN DRAWINGS FOR CONDUIT, TYPE, SIZE, AND QUANTITY.
 - RGC 90 DEGREES LONG SWEEP ELBOW IN TRENCH, SEE PLAN DRAWINGS FOR CONDUIT, TYPE, SIZE, AND QUANTITY. THIS WORK SHALL BE INSTALLED UNDER THE "ELECTRIC SERVICE INSTALLATION" PAY ITEM.
 - UNDER THE "ELECTRIC UTILITY SERVICE CONNECTION" PAY ITEM, COMMONWEALTH EDISON COMPANY SHALL FURNISH AND INSTALL METER ON CONTROL CABINET.
 - COMMONWEALTH EDISON COMPANY SHALL FURNISH AND INSTALL SERVICE POLE INSTALLATION, PAD MOUNTED TRANSFORMER, CUT-OUT SWITCH, LIGHTNING ARRESTOR, GROUNDING EQUIPMENT, PRIMARY CABLE, AND ANY OTHER LABOR AND EQUIPMENT DEEMED NECESSARY.
 - FURNISH AND INSTALL GROUND ROD, CONDUCTOR AND CLAMPS FOR GROUNDING METALLIC CONDUIT ON POLE. THE COST OF THIS WORK SHALL BE CONSIDERED INCIDENTAL TO "ELECTRIC SERVICE INSTALLATION" PAY ITEM. SEPARATE PAYMENT WILL NOT BE MADE.
 - SEE IDOT STANDARD DRAWING BE-205 FOR LIGHTING CONTROLLER AND FOUNDATION DETAILS.
 - SUBMIT A PLAN DRAWING SHOWING THE PROPOSED PRIMARY CONDUIT INSTALLATION TO COMMONWEALTH EDISON COMPANY FOR THEIR APPROVAL. THIS WORK SHALL BE COVERED UNDER THE "ELECTRIC SERVICE INSTALLATION" PAY ITEM. SEPARATE PAYMENT WILL NOT BE MADE.

ComEd SYSTEM STANDARD

ELECTRIC SERVICE INSTALLATION DETAIL
 N.T.S.

McDonough Associates Inc.
 Engineers / Architects
 130 East Randolph Street Chicago, Illinois 60601

© Notice: The information contained on this page is the sole property of ComEd and is to be used only in conjunction with electric service provided by ComEd.

FILE NAME = D160F12-SHT-ED-8.dgn	USER NAME = TKLuegel	DESIGNED - JLW	REVISED -	STATE OF ILLINOIS DEPARTMENT OF TRANSPORTATION	I-55 AT ARSENAL ROAD ELECTRIC SERVICE INSTALLATION PAD MOUNTED TRANSFORMER			F.A.I. RTE. 55	SECTION 99-2HB-2B-1	COUNTY WILL	TOTAL SHEETS 756	SHEET NO. 423
PLOT SCALE = .5	CHECKED - KMY	DATE - 2/4/11	REVISED -		SCALE:	SHEET NO. 1 OF 1 SHEET	STA.	TO STA.	CONTRACT NO. 60F12			
PLOT DATE = 2/3/2011	DATE - 2/4/11	REVISED -	REVISED -		FED. ROAD DIST. NO. 1 ILLINOIS FED. AID PROJECT							
ED-8												

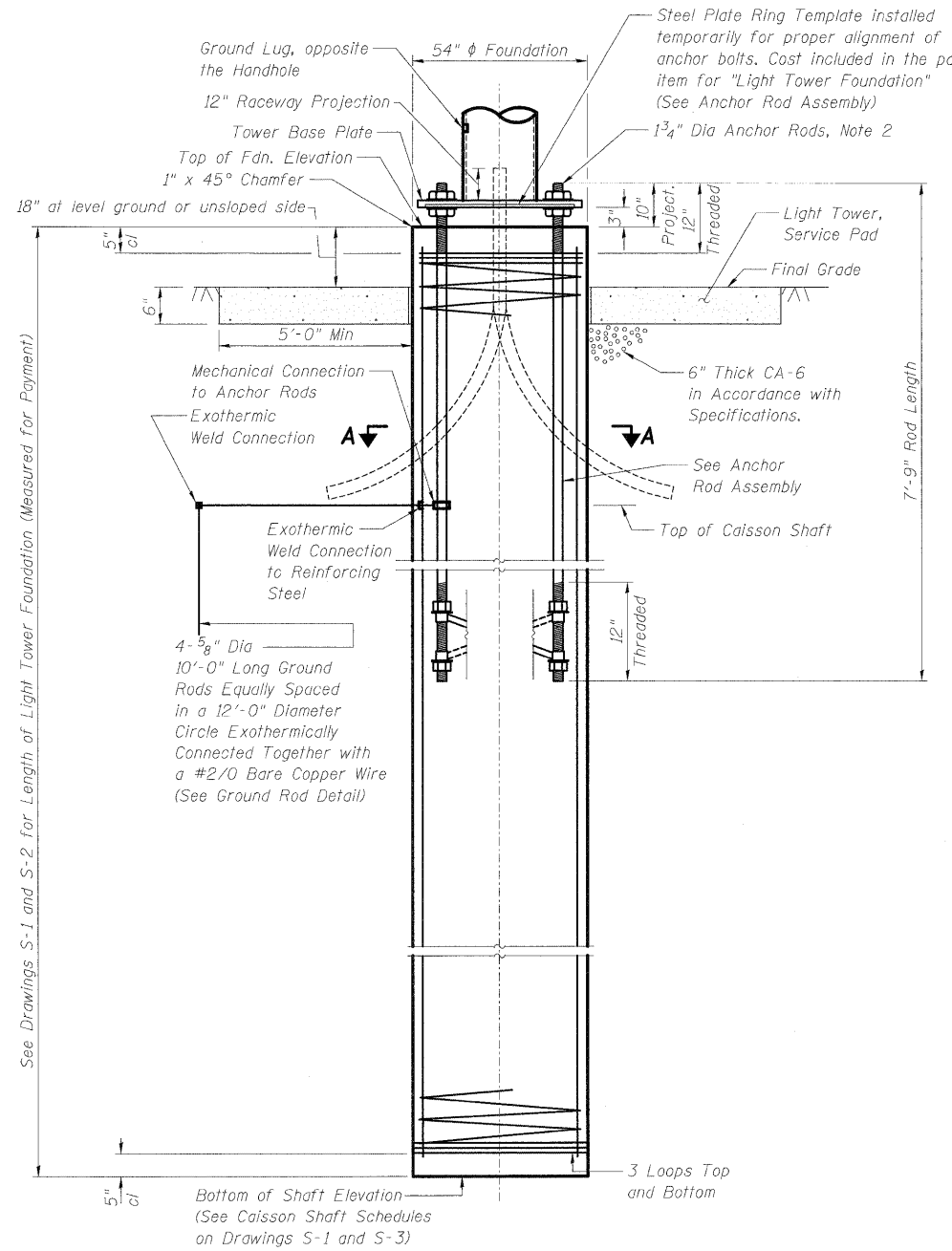

FOUNDATION ELEVATION

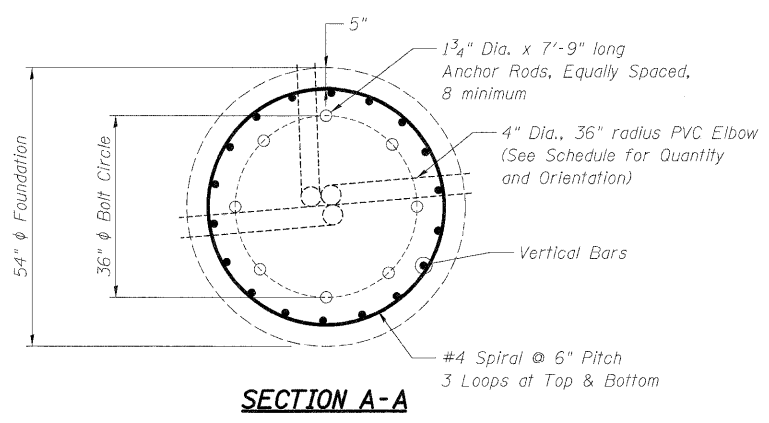

SECTION A-A

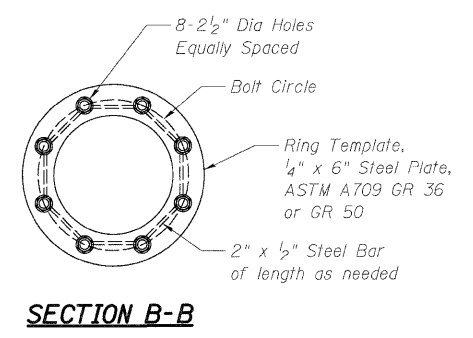

SECTION B-B

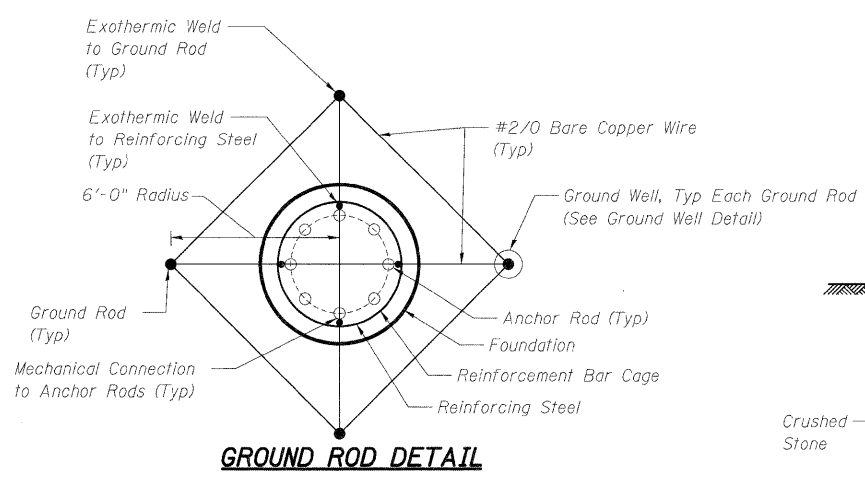

GROUND ROD DETAIL

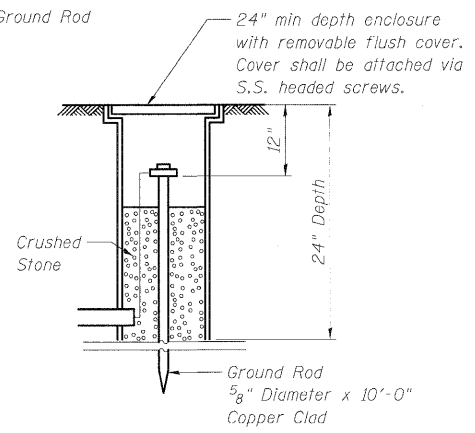

GROUND WELL DETAIL

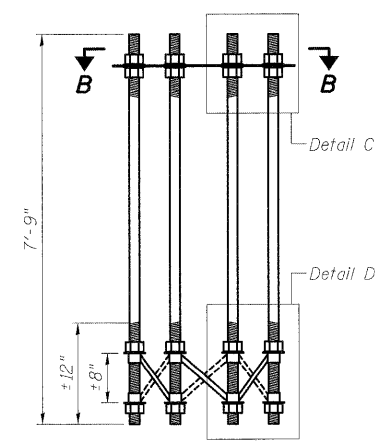

ANCHOR ROD ASSEMBLY

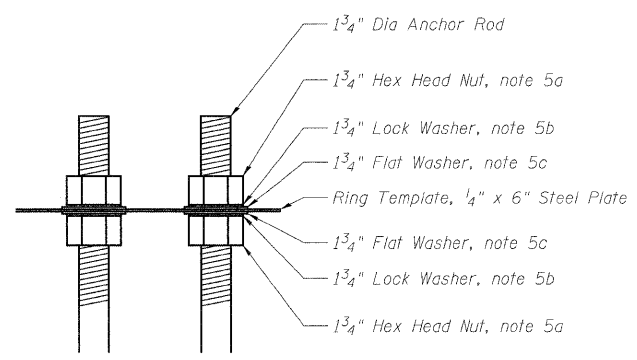

DETAIL C

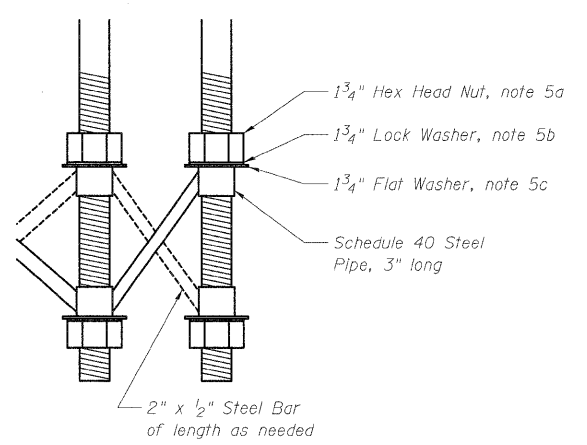

DETAIL D

NOTES:

1. THE INFORMATION ON THIS DRAWING SHALL BE UTILIZED WITH STRUCTURAL DRAWINGS S-1 THRU S-3 FOR THE CONSTRUCTION OF LIGHT TOWER FOUNDATIONS.
2. A MINIMUM OF THREE FULL THREADS SHALL REMAIN EXPOSED AFTER LIGHT TOWER IS INSTALLED.
3. ALL GROUNDING INDICATED IN THE PLANS SHALL BE INCLUDED IN THE COST OF THE LIGHT TOWER FOUNDATION AND SHALL NOT BE PAID FOR SEPARATELY.
4. CUT NUTS, OR JAM NUTS, ARE NOT ALLOWED.
5. ANCHOR ROD CAGE HARDWARE SHALL BE IN ACCORDANCE WITH THE FOLLOWING:
 - a) 1 3/4" HEX HEAD NUTS
AASHTO M291, GRADE C, C3, D, DH, OR DH3
HOT DIPPED GALVANIZED AASHTO M232
 - b) 1 3/4" HELICAL LOCK WASHERS
ANSI/ASME B18.21.1
I.D. 1.758 - 1.778
O.D. 2.596 MAX.
WIDTH 0.383 MIN.
THICKNESS 0.469 MIN.
HARDNESS 26-45 ROCKWELL C
HOT DIPPED GALVANIZED AASHTO M232
 - c) 1 3/4" FLAT WASHERS
AASHTO M293
O.D. 3.25
I.D. 1.875
THICKNESS 0.16 - 0.25
HARDNESS 26-45 ROCKWELL C
HOT DIPPED GALVANIZED AASHTO M232
6. THE SHAFT LENGTHS SHALL BE BASED ON SOIL BORINGS IN THE PLANS AND/OR A DETERMINATION OF SOIL CONDITIONS BY THE ENGINEER.
7. ALL FOUNDATION REINFORCEMENT STEEL SHALL BE EPOXY COATED.
8. THE FOUNDATION SHALL BE POURED MONOLITHICALLY AND SHALL HAVE NO CONSTRUCTION JOINTS.

McDonough Associates Inc.
Engineers / Architects
130 East Randolph Street, Chicago, Illinois 60601

FILE NAME =	USER NAME = TKLuegel	DESIGNED - JLW	REVISED -
D162P12-SHT-ED-9.dgn		DRAWN - CJM	REVISED -
	PLOT SCALE = 1:1	CHECKED - KMY	REVISED -
	PLOT DATE = 2/3/2011	DATE = 2/4/11	REVISED -

STATE OF ILLINOIS
DEPARTMENT OF TRANSPORTATION

I-55 AT ARSENAL ROAD
HIGH MAST LIGHT TOWER FOUNDATION DETAILS

F.A.I. RTE.	SECTION	COUNTY	TOTAL SHEETS	SHEET NO.
55	99-2HB-2B-1	WILL	756	424
CONTRACT NO. 60F12				
FED. ROAD DIST. NO. 1 ILLINOIS FED. AID PROJECT				

SCALE: SHEET NO. 1 OF 1 SHEETS STA. TO STA.

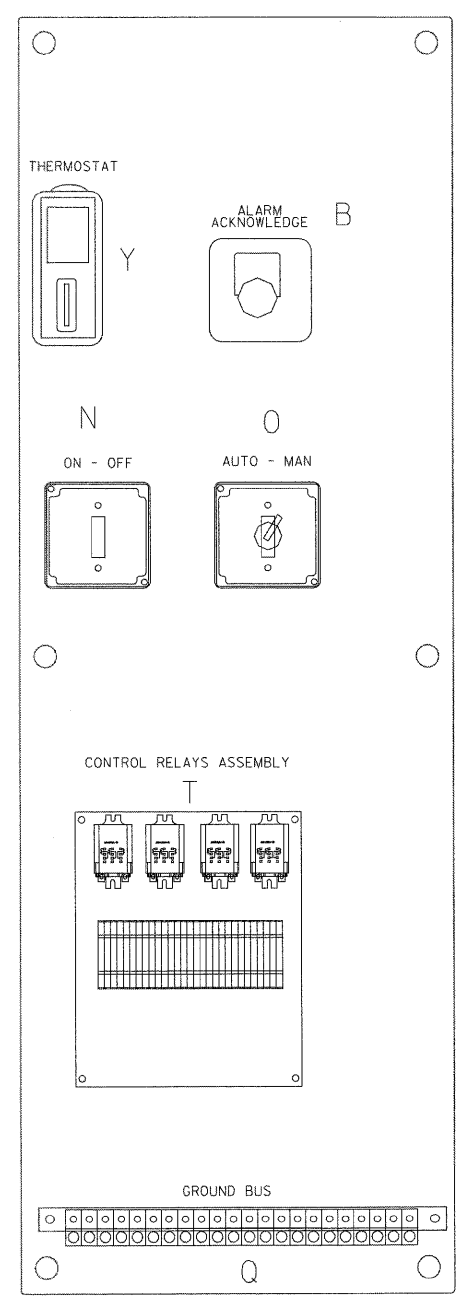
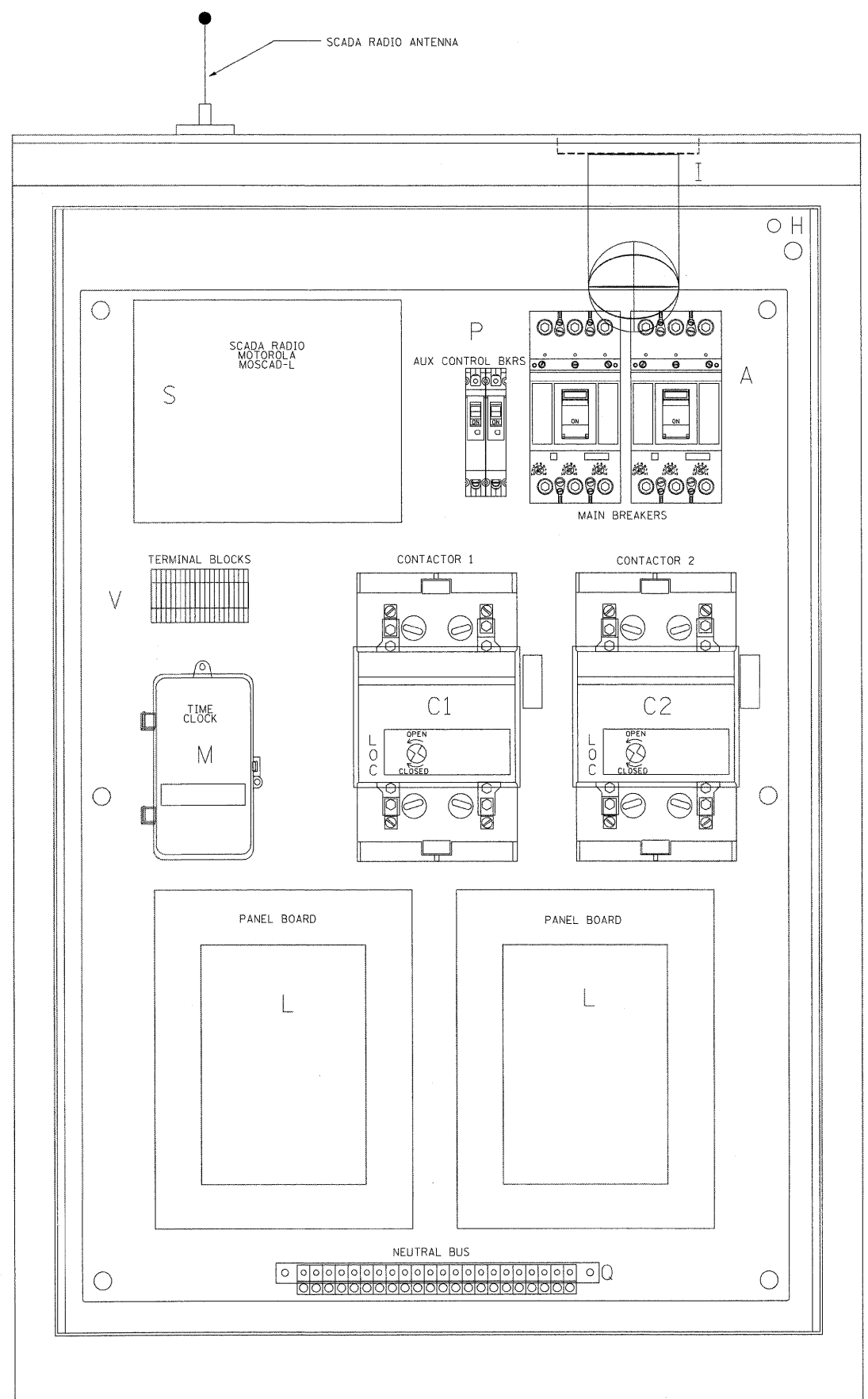

LEFT SIDE PANEL

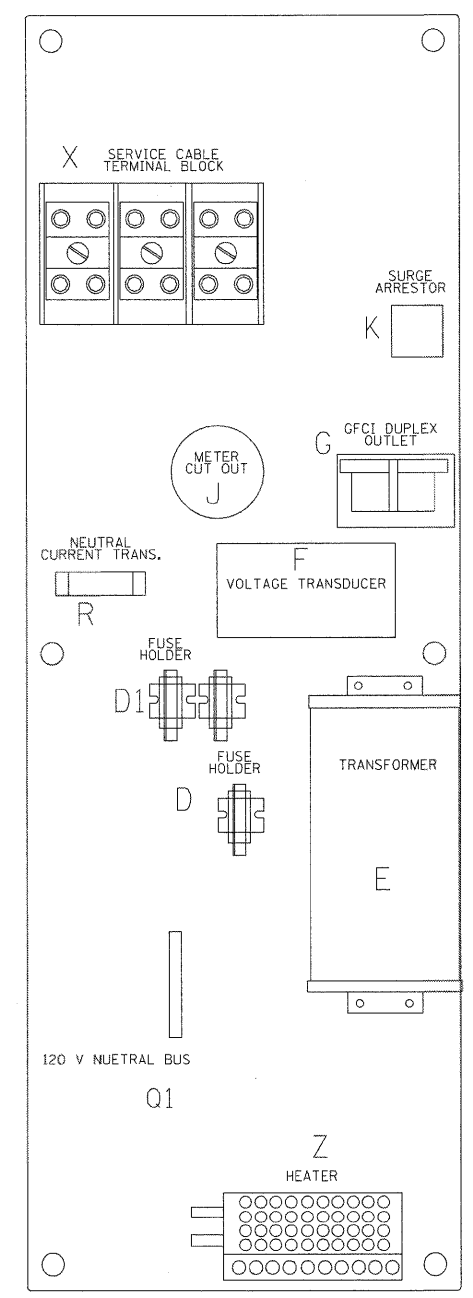

RIGHT SIDE PANEL

BILL OF MATERIALS		
ITEM	QTY	DESCRIPTION
A	2	MAIN CIRCUIT BREAKERS 2 POLE 175 AMP WITH AUX CONTACT
B	1	ACKNOWLEDGE SWITCH, PUSH BUTTON WITH YELLOW INSERT
C1, C2*	2	CONTACTOR 2 POLE 200 AMP 240V COIL WITH AUX CONTACTS
D	1	FINGERSAFE FUSE HOLDER WITH KTK-15 FUSE
D1	2	FINGERSAFE FUSE HOLDER WITH KTK-1/2 FUSE
E	1	2.0 KVA 277V-240/120 TRANSFORMER
F	1	VOLTAGE TRANSDUCER WITH COVERED TERMINALS
G	1	15 AMP GFCI DUPLEX OUTLET W/COVER
H	2	DOOR SWITCH
I	1	LIGHT FIXTURE
J	1	METER FITTING 1 PHASE 3 WIRE 200 AMP
K	1	SURGE ARRESTER
L	2	PANEL BOARD 480/240V 1 PHASE, 250 AMP COPPER BUS
M	1	2 CHANNEL DIGITAL TIME CLOCK
N	1	MOMENTARY SWITCH ON - OFF
O	1	SQUARE D, 900IKS11BH13, 2 POSITION SWITCH IN 900IKY1 ENCLOSURE OR APPROVED EQUAL
P	2	BREAKER 1P 15A
Q	2	COPPER GROUND AND NEUTRAL BUS 1 x 16 x 1/4
Q1	1	COPPER NEUTRAL BUS WITH 1 #6 AND 8 #12 CONDUCTOR POINTS
R	1	CURRENT TRANSDUCER
S	1	MOTOROLA MOSCAD-L RADIO, 240 V
T*	1	CONTROL RELAY ASSEMBLY 240V COILS WITH 4 3 PDT 25A RELAYS (W389ACX-15) (R1, R2, R3, R4) . QTY 32 TERMINAL BLOCKS
V	20	TERMINAL BLOCKS
X*	1	620 AMP SLPICE BLOCK
Y	1	40-80 DEG THERMOSTAT
Z	1	375 WATT HEATER

* TERMINALS SHALL BE COVERED WITH CLEAR PLEXIGLASS SHEET

McDonough Associates Inc.
 Engineers/Architects
 130 East Randolph Street Chicago, Illinois 60601

FILE NAME = D:\B\F12-SHT-BE-205a.dgn	USER NAME = TKluegel	DESIGNED - IDOT	REVISED -
		DRAWN - CJM	REVISED -
		CHECKED - KMY	REVISED -
		DATE - 2/4/11	REVISED -

STATE OF ILLINOIS
DEPARTMENT OF TRANSPORTATION

LIGHTING CONTROLLER, RADIO CONTROL DUPLEX TYPE WITH SCADA			
SCALE:	SHEET NO. 1 OF 4 SHEETS	STA.	TO STA.

F.A.I. RTE.	SECTION	COUNTY	TOTAL SHEETS	SHEET NO.
55	99-2HB-2B-1	WILL	756	425
CONTRACT NO. 60F12				
FED. ROAD DIST. NO. 1 ILLINOIS FED. AID PROJECT				

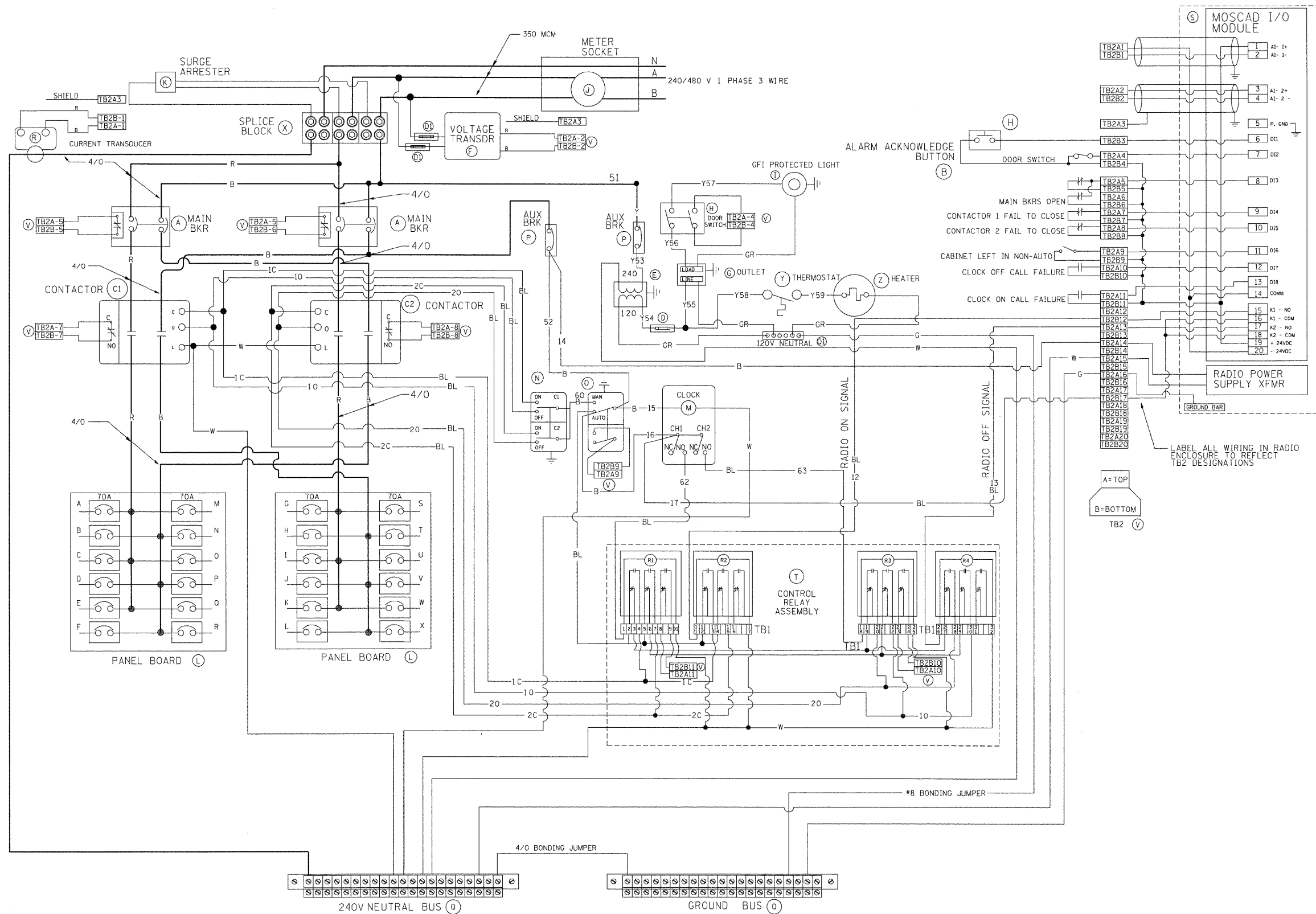

BILL OF MATERIALS		
ITEM #	QTY	DESCRIPTION
A	2	MAIN CIRCUIT BREAKERS 2 POLE 175 AMP WITH AUX CONTACT
B	1	ACKNOWLEDGE SWITCH, PUSH BUTTON WITH YELLOW INSERT
C1, C2	2	CONTACTOR 2 POLE 200 AMP 240V COIL WITH AUX CONTACTS
D	1	FINGERSAFE FUSE HOLDER WITH KTK-10 FUSE
D1	2	FINGERSAFE FUSE HOLDER WITH KTK-1/2 FUSE
E	1	2.0 KVA 277V-240/120 TRANSFORMER
F	1	VOLTAGE TRANSDUCER
G	1	15 AMP GFCI DUPLEX OUTLET W/COVER
H	2	DOOR SWITCH A-20G0-BT-K
I	1	LIGHT FIXTURE
J	1	METER FITTING 1 PHASE 3 WIRE 200 AMP
K	1	SURGE ARRESTER
L	2	PANEL BOARD 480/240V 1 PHASE, 250 AMP COPPER BUS
M	1	2 CHANNEL DIGITAL TIME CLOCK
N	1	MOMENTARY SWITCH ON - OFF
O	1	SQUARE D, 900IKS11BH13, 2 POSITION SWITCH IN 900IKY1 ENCLOSURE
P	2	BREAKER IP 15A
Q	2	COPPER GROUND AND NEUTRAL BUS 1 x 16 x 1/4
Q1	1	COPPER NEUTRAL BUS WITH 1 1/0 AND #6 CONDUCTOR POINTS
R	1	CURRENT TRANSDUCER
S	1	MOTOROLA MOSCAD-L RADIO, 240 V
T	1	CONTROL RELAY ASSEMBLY 240V COILS WITH 4 3 PDT 25A RELAYS (W389ACX-15) (R1, R2, R3, R4) . QTY 32 TERMINAL BLOCKS
V	20	TERMINAL BLOCKS
X	1	620 AMP SPLICE BLOCK
Y	1	40-80 DEG THERMOSTAT
Z	1	375 WATT HEATER

FILE NAME = D16ZF12-SHT-BE-205b.dgn	USER NAME = TKluegal	DESIGNED - IDOT	REVISED -
		DRAWN - CJM	REVISED -
		CHECKED - KMY	REVISED -
		DATE - 2/4/11	REVISED -

**STATE OF ILLINOIS
DEPARTMENT OF TRANSPORTATION**

**LIGHTING CONTROLLER, RADIO CONTROL
DUPLEX TYPE WITH SCADA**

SCALE: SHEET NO. 2 OF 4 SHEETS STA. TO STA.

F.A.I R.T.E.	SECTION	COUNTY	TOTAL SHEETS	SHEET NO.
55	99-2HB-2B-1	WILL	756	426
CONTRACT NO. 60F12				
FED. ROAD DIST. NO. 1 ILLINOIS FED. AID PROJECT				

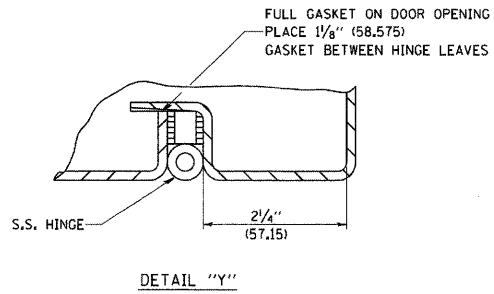

DETAIL "Y"

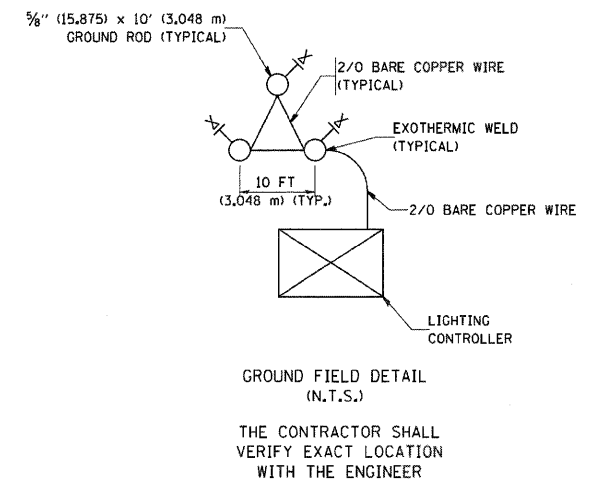
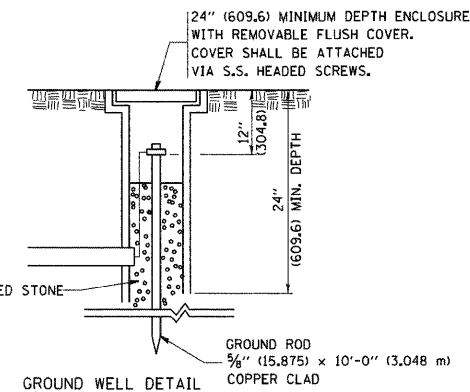
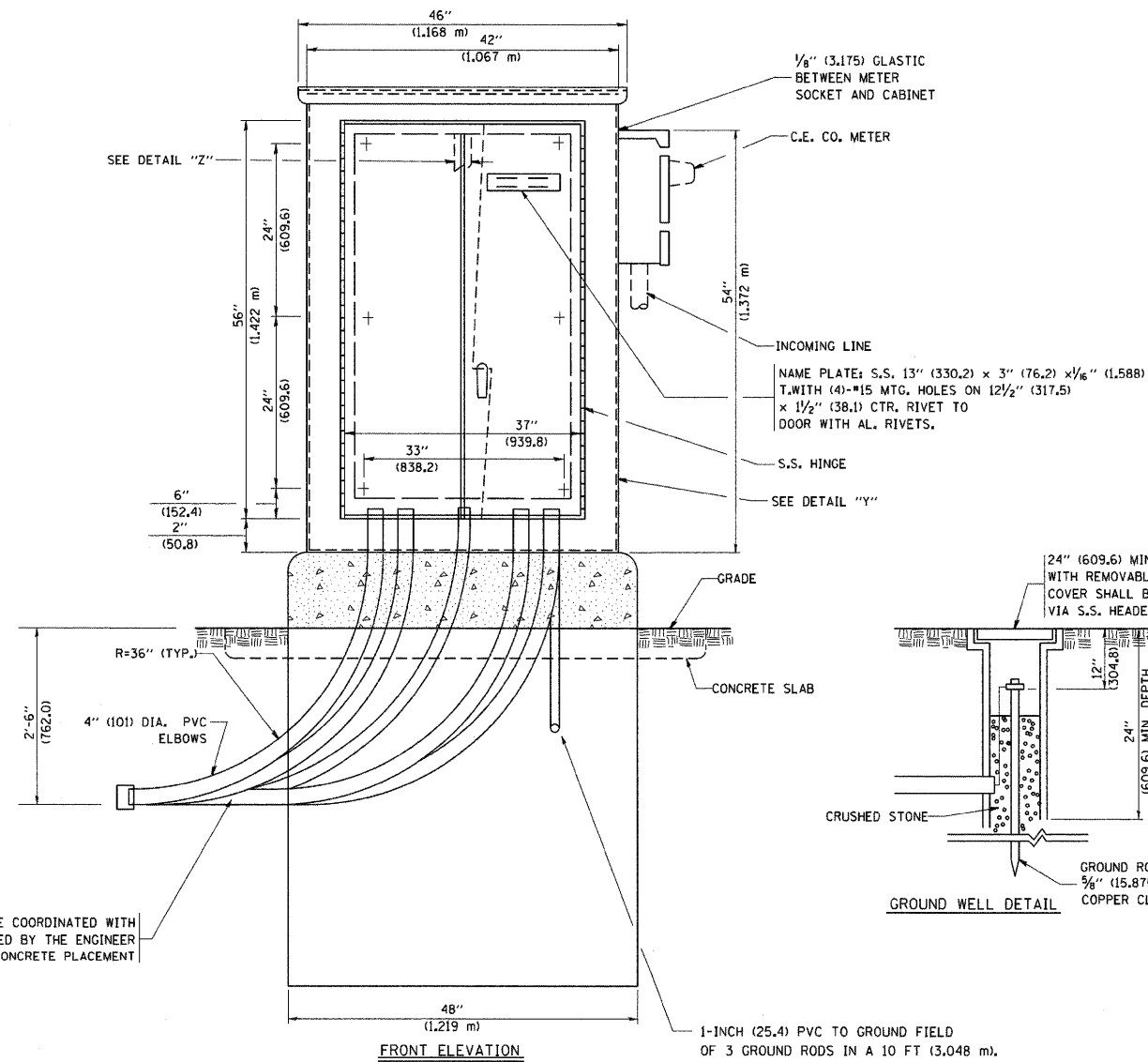
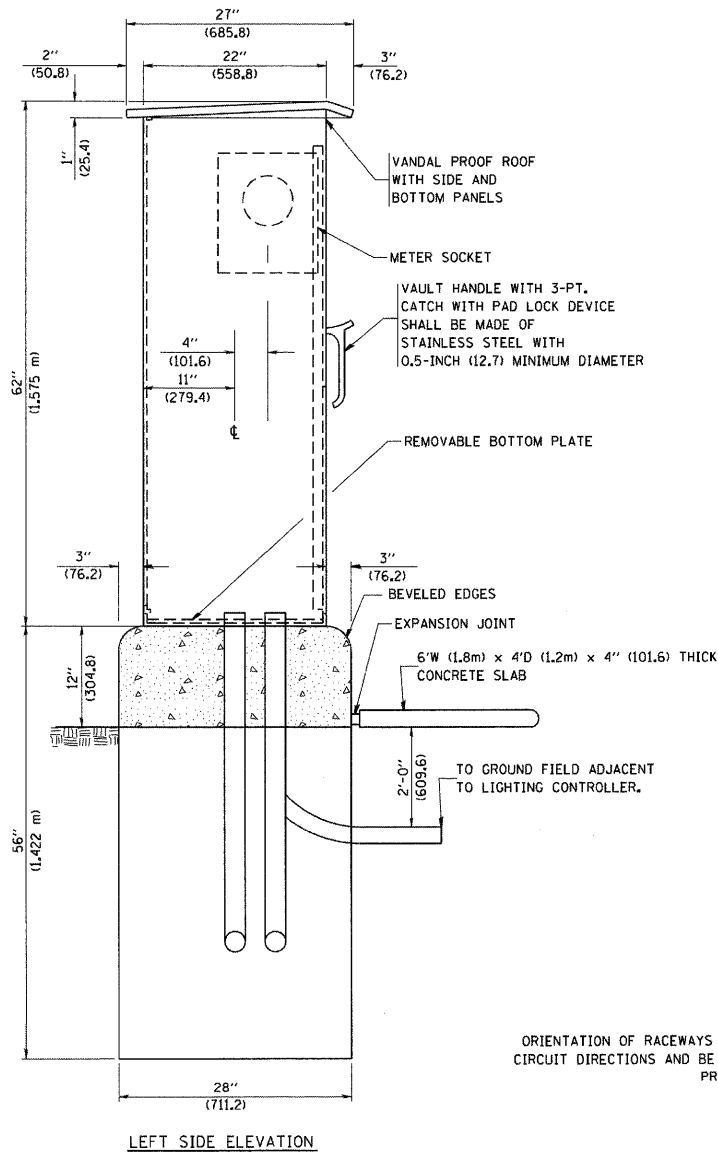
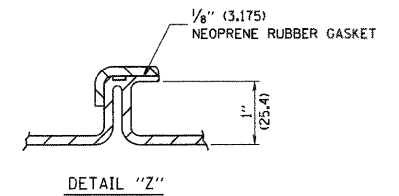
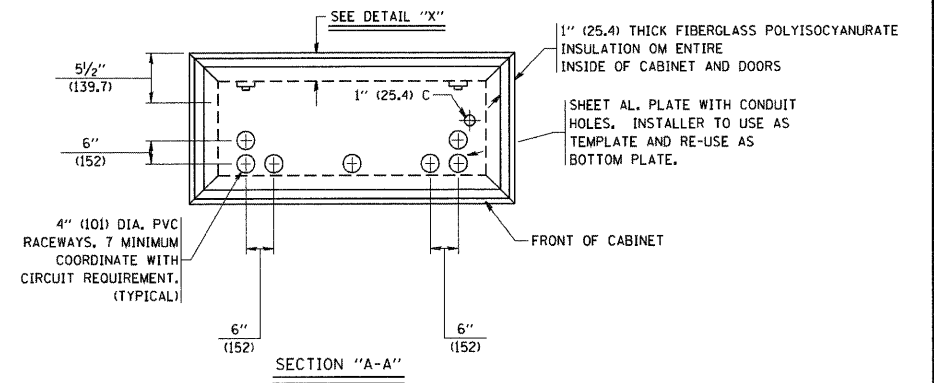
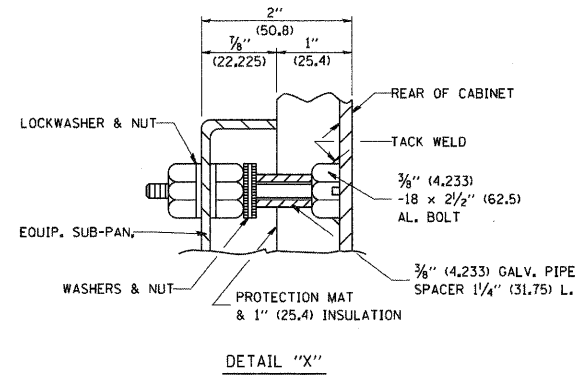
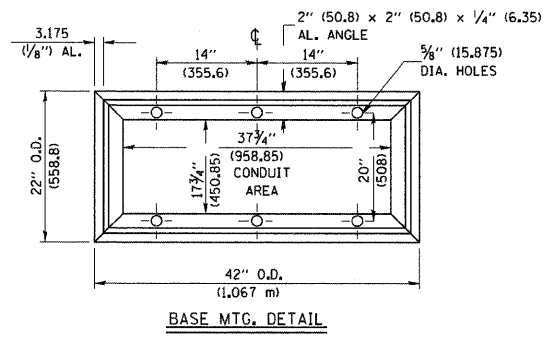

ORIENTATION OF RACEWAYS SHALL BE COORDINATED WITH CIRCUIT DIRECTIONS AND BE INSPECTED BY THE ENGINEER PRIOR TO CONCRETE PLACEMENT

1-INCH (25.4) PVC TO GROUND FIELD OF 3 GROUND RODS IN A 10 FT (3,048 m) TRIANGLE CONNECTED VIA BARE COPPER WIRE. VERIFY EXACT LOCATION OF GROUND FIELD WITH THE ENGINEER. NO GROUND WELL SHALL BE PLACED IN CONCRETE PAD IN FRONT OF CONTROLLER.

NOTES

- CABINET SHALL BE FABRICATED FROM 0.125-INCH (3.175) SHEET ALUMINUM #3003H14, FORMED AND ARC WELDED.
- ALL SCREWS AND HARDWARE SHALL BE PLATED, GALVANIZED, OR MADE OF BRASS, ALUMINUM OR STAINLESS STEEL, UNLESS OTHERWISE NOTED.
- NAME PLATE SHALL HAVE ENGRAVED 0.75-INCH (19.05) HIGH LETTERS FILLED IN BLACK: "STATE OF ILLINOIS LIGHTING CONTROLS" UNLESS OTHERWISE SPECIFIED.
- ONE INCH THICK POLYISOCYANURATE INSULATION SHALL BE INSTALL AND PERMANENTLY CEMENTED ON ALL SIDES OF THE CABINET AND DOORS.
- CABINET SHALL BE PRIMED AND PAINTED AS SPECIFIED.
- ELECTRIC UTILITY METER BOX SHALL BE MOUNTED ON THE SIDE OF CONTROL CABINET AS SHOWN ON THE PANEL LAYOUT DIAGRAM.
- THE COMPLETED CONTROLLER SHALL BE U.L. LISTED AS AN INDUSTRIAL CONTROL PANEL UNDER UL508.
- METAL MOUNTING PANEL SHALL BE FABRICATED FROM THE SAME MATERIAL AS THE CABINET AND SHALL BE FLANGED BACK 0.75-INCHES I.D. ON 4 SIDES.
- CIRCUIT BREAKERS AND CONTACTORS AND OTHER COMPONENTS SHALL BE MOUNTED ON 0.125-INCH (3.175) THICK GLASTIC INSULATION BACK PANEL.
- ALL DEVICES SHALL BE FRONT REMOVABLE.
- TIME CLOCK CHANNEL 1 N.O. CONTACT IS CLOSED NIGHT AND OPEN DAY (LIGHTS ON).
- SET LATITUDE TO 42 DEGREES. SET CH.1 TO 25 MINUTES AFTER ASTRONOMICAL SUNSET, 40 MINUTES BEFORE ASTRONOMICAL SUNRISE. SET CH.2 TO 60 MINUTES AFTER ASTRONOMICAL SUNSET (WITH A SIGNAL LENGTH OF 1 SECOND), +20 MINUTES AFTER ASTRONOMICAL SUNRISE (WITH A SIGNAL LENGTH OF 7 SECONDS.)
- BUS BAR SHALL HAVE 22 LUG TERMINALS SIZED TO ACCOMMODATE REQUIRED WIRE SIZES. 240V NEUTRAL BUS SHALL BE PAINTED WHITE, GROUND BUS SHALL BE PAINTED GREEN, AND THE 120V NEUTRAL BUS SHALL BE PAINTED GREY.
- ALL LUGS SHALL BE OF COPPER SCREWS AND CONNECTORS, SPRING HELD.
- ALL WIRING TERMINATIONS SHALL BE RATED NOT LESS THAN 75 DEGREE CENTIGRADE.
- ALL CONTROL WIRING SHALL BE 600V #12 TYPE MTW.
- ALL POWER WIRING SHALL BE 600V TYPE RHH/RHW.
- ALL WIRING WITHIN THE CABINET SHALL BE COLOR CODED AS INDICATED:

R - RED	Y - YELLOW
B - BLACK	W - WHITE
BL - BLUE	G - GREEN
	GR - GREY
- MOSCAD I/O WIRING SHALL BE:
 - DIGITAL INPUT (DI) WIRING SHALL BE #16 MTW PURPLE.
 - ANALOG INPUT (AI) WIRING SHALL BE #18, 2/C SHIELDED.
 - AI AND DI WIRING MAY BE BUNDLED TOGETHER, BUT SHALL NOT BE BUNDLED WITH OTHER WIRING.
- ALL DIMENSIONS ARE IN INCHES (MILLIMETERS) UNLESS OTHERWISE INDICATED.
- SCHEMATIC SHOWN WITH BREAKER OPEN, CONTACTOR OPEN, CABINET DOOR CLOSED, CLOCK NOT ACTIVE (DE-ENERGIZED STATE).
- A LAMINATED COPY OF THE CIRCUIT SCHEMATIC AND SCADA I/O DIAGRAM (NO SMALLER THAN 11"x17" EACH) SHALL BE ATTACHED TO THE INSIDE OF THE CONTROLLER WITH STAINLESS STEEL SCREWS.

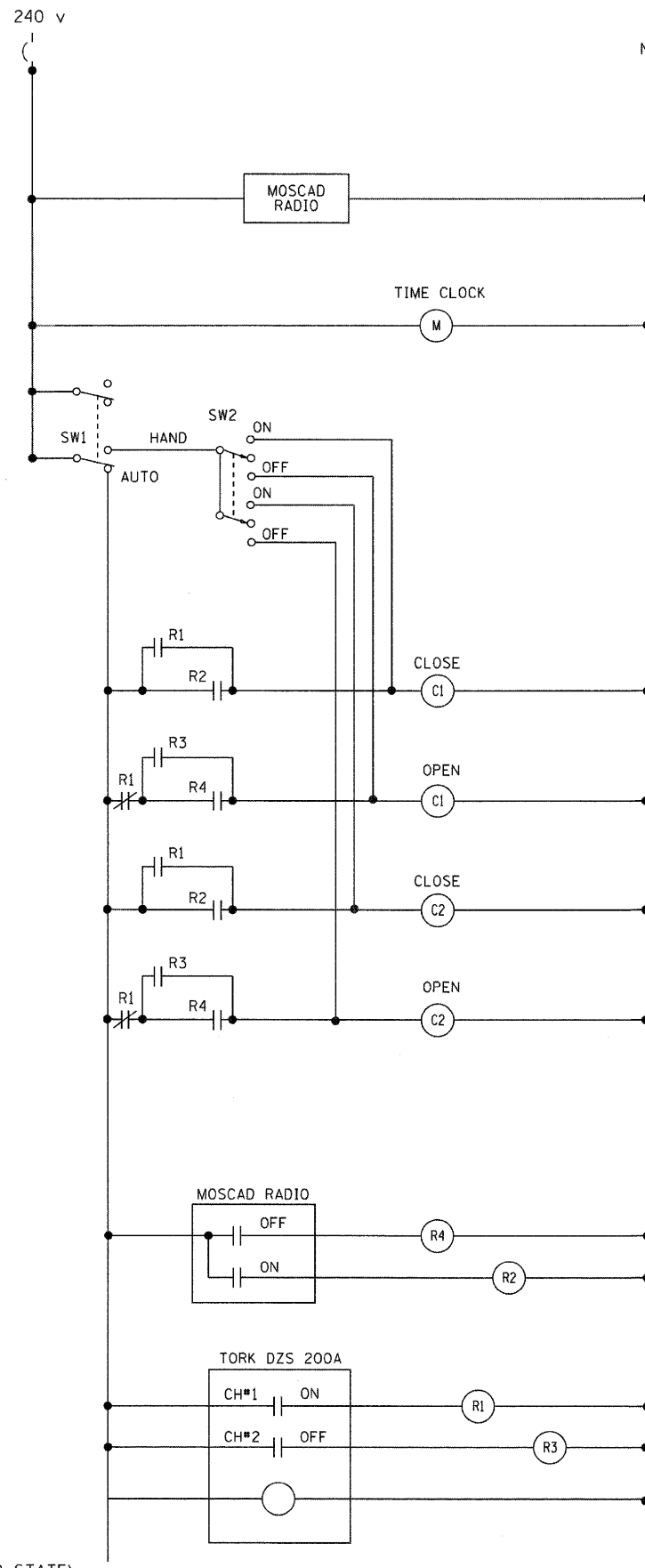

CONTROL CIRCUIT LADDER LOGIC DIAGRAM

MOSCAD I/O ASSIGNMENTS		
TERM	MOSCAD DESTINATION	DESCRIPTION OF INPUT
1	ANALOG INPUT 1 (+)	CABINET NEUTRAL CURRENT
2	ANALOG INPUT 1 (-)	CABINET NEUTRAL CURRENT
3	ANALOG INPUT 2 (+)	CABINET SERVICE VOLTAGE
4	ANALOG INPUT 2 (-)	CABINET SERVICE VOLTAGE
5	P. GROUND	GROUND
6	DIGITAL INPUT 1	ALARM KNOWLEDGE
7	DIGITAL INPUT 2	DOOR OPEN
8	DIGITAL INPUT 3	MAIN(S) BREAKER OPEN
9	DIGITAL INPUT 4	CONTACTOR 1 OPEN
10	DIGITAL INPUT 5	CONTACTOR 2 OPEN
11	DIGITAL INPUT 6	CABINET IN NON-AUTO
12	DIGITAL INPUT 7	BACK-UP CLOCK OFF CALL
13	DIGITAL INPUT 8	BACK-UP CLOCK ON CALL
14	DI COMMON	COMMON
15	K1 NO	LIGHTS ON CALL
16	K1 C	K1 COMMON
17	K2 NO	LIGHTS OFF CALL
18	K2 C	K2 COMMON
19	24 V+	24+VDC
20	24 V-	24-VDC

ALL ANALOG INPUTS WILL BE 4-20 MA ONLY. DIGITAL OUTPUT RELAYS WILL BE ELECTRICALLY ENERGIZED AND MOMENTARILY HELD
MIXED I/O MODULE MODEL NUMBER V436

FILE NAME = 0160F12-SHT-BE-205d.dgn	USER NAME = TK:uegal	DESIGNED - IDOT	REVISED -
		DRAWN - CJM	REVISED -
		CHECKED - KMY	REVISED -
		DATE - 2/4/11	REVISED -

F.A.I. RTE. 55	SECTION 99-2HB-2B-1	COUNTY WILL	TOTAL SHEETS 756	SHEET NO. 428
CONTRACT NO. 60F12			ILLINOIS FED. AID PROJECT	

APPLICATION

THIS DETAIL APPLIES FOR LOW VOLTAGE ELECTRIC SERVICE (660 V OR LESS) FROM AN OVERHEAD UTILITY SUPPLY TO SEPERATLY-MOUNTED SERVICE EQUIPMENT.

NOTES

- SERVICE VOLTAGE SHALL BE AS INDICATED ELSEWHERE IN THE DRAWINGS.
- UNLESS OTHERWISE INDICATED, ITEMS AND WORK SHALL BE INCLUDED AND PAID AS PART OF THE ELECTRIC UTILITY SERVICE INSTALLATION PAY ITEM.
- CONDUIT AND CONNECTOR DIAMETER SHALL MATCH THE DIAMETER OF THE SERVICE CONDUCTOR RACEWAY AS INDICATED ON THE PLANS.
- PVC COATED RACEWAYS AND ACCESSORIES SHALL BE CAREFULLY INSTALLED WITH MFR RECOMMENDED TOOLS AND PROCEDURES TO AVOID DAMAGE. ANY DAMAGE SHALL BE REPAIRED WITH COMPATIBLE PVC TOUCH-UP MATERIAL TO THE SATISFACTION OF THE ENGINEER OR THE DAMAGED MATERIAL SHALL BE REPLACED AT NO ADDITIONAL COST.
- THE CONTRACTOR SHALL OBTAIN INSPECTION AND APPROVAL BY THE ENGINEER OF SERVICE RISER GROUND ELECTRODE, RISER ELBOW, NIPPLE AND CONNECTION TO SERVICE CONDUCTOR RACEWAY EXTENSION BEFORE BACKFILL AND SHALL ALSO OBTAIN INSPECTION OF SERVICE RISER AND SEALING BUSHING BEFORE UTILITY "U" GUARD INSTALLATION AND SERVICE CONNECTION.
- THE HORIZONTAL ELECTRIC SERVICE CONDUCTOR RACEWAY SHALL BE AS INDICATED AND SHALL BE MEASURED SEPARATELY FOR PAYMENT. WHEN THE RACEWAY IS PVC-COATED RIGID GALVANIZED STEEL, THE COUPLING SHALL BE THE SAME. WHEN THE RACEWAY IS PVC CONDUIT (IN CONCRETE), THE COUPLING SHALL BE A METALIC TO NON METALIC ADAPTER, WHEN THE RACEWAY IS ENCASED IN CONCRETE, THE CONCRETE SHALL EXTEND TO COVER THE COUPLING.
- PLANS AND DETAILS INDICATE THE GENERAL NATURE AND REQUIREMENTS. THEY DO NOT SHOW EVERY ACCESSORY AND ATTACHMENT, AND THEY DO NOT RELIEVE THE CONTRACTOR OF THE REQUIREMENTS OF THE SPECIFICATIONS AND SPECIAL PROVISIONS TO ASCERTAIN UTILITY REQUIREMENTS AND TO COORDINATE ACCORDINGLY, FURNISHING ALL ITEMS AND WORK NOT PROVIDED BY THE UTILITY, BUT NECESSARY FOR A COMPLETE SERVICE INSTALLATION IS REQUIRED AND SHALL BE INCLUDED IN THE ELECTRIC UTILITY SERVICE INSTALLATION PAY ITEM.

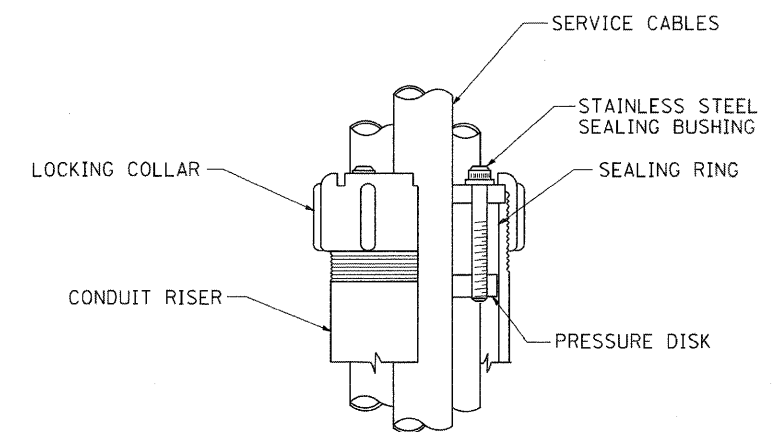

SEALING BUSHING DETAIL

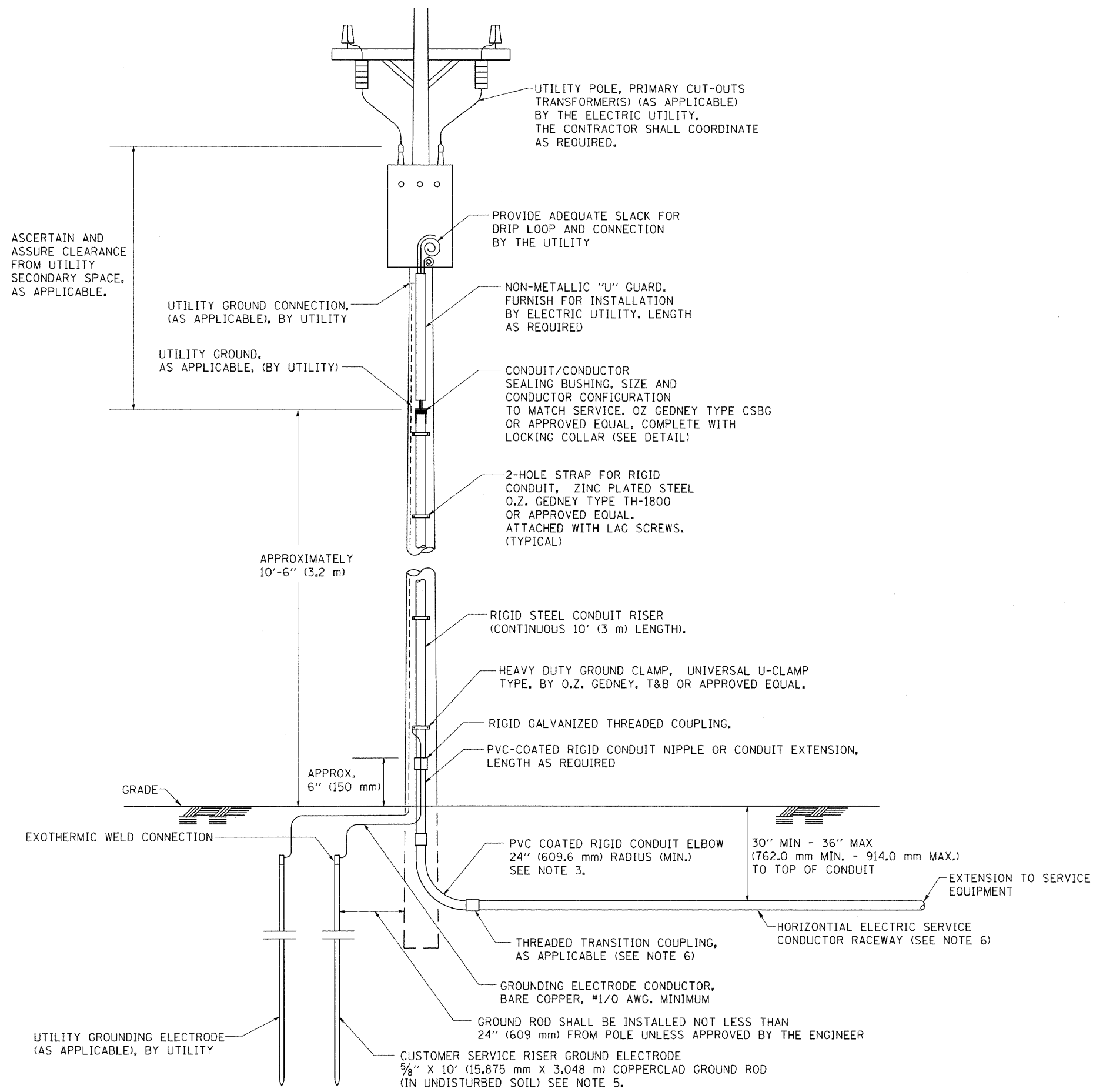

McDonough Associates Inc.
 Engineers / Architects
 130 East Randolph Street, Chicago, Illinois 60601

FILE NAME = D150F12-SHT-BE-220.dgn	USER NAME = TKIuegel	DESIGNED - IDOT	REVISED -	STATE OF ILLINOIS DEPARTMENT OF TRANSPORTATION	ELECTRIC SERVICE INSTALLATION AERIAL, REMOTE DISCONNECT			F.A.I RTE. 55	SECTION 99-2HB-2B-1	COUNTY WILL	TOTAL SHEETS 756	SHEET NO. 429
PLOT SCALE = 1:1	CHECKED - KMY	DRAWN - CJM	REVISED -		SCALE:	SHEET NO. 1 OF 1 SHEETS	STA.	TO STA.	CONTRACT NO. 60F12			
PLOT DATE = 2/3/2011	DATE - 2/4/11	CHECKED - KMY	REVISED -		FED. ROAD DIST. NO. 1 ILLINOIS FED. AID PROJECT							
		DATE - 2/4/11	REVISED -									

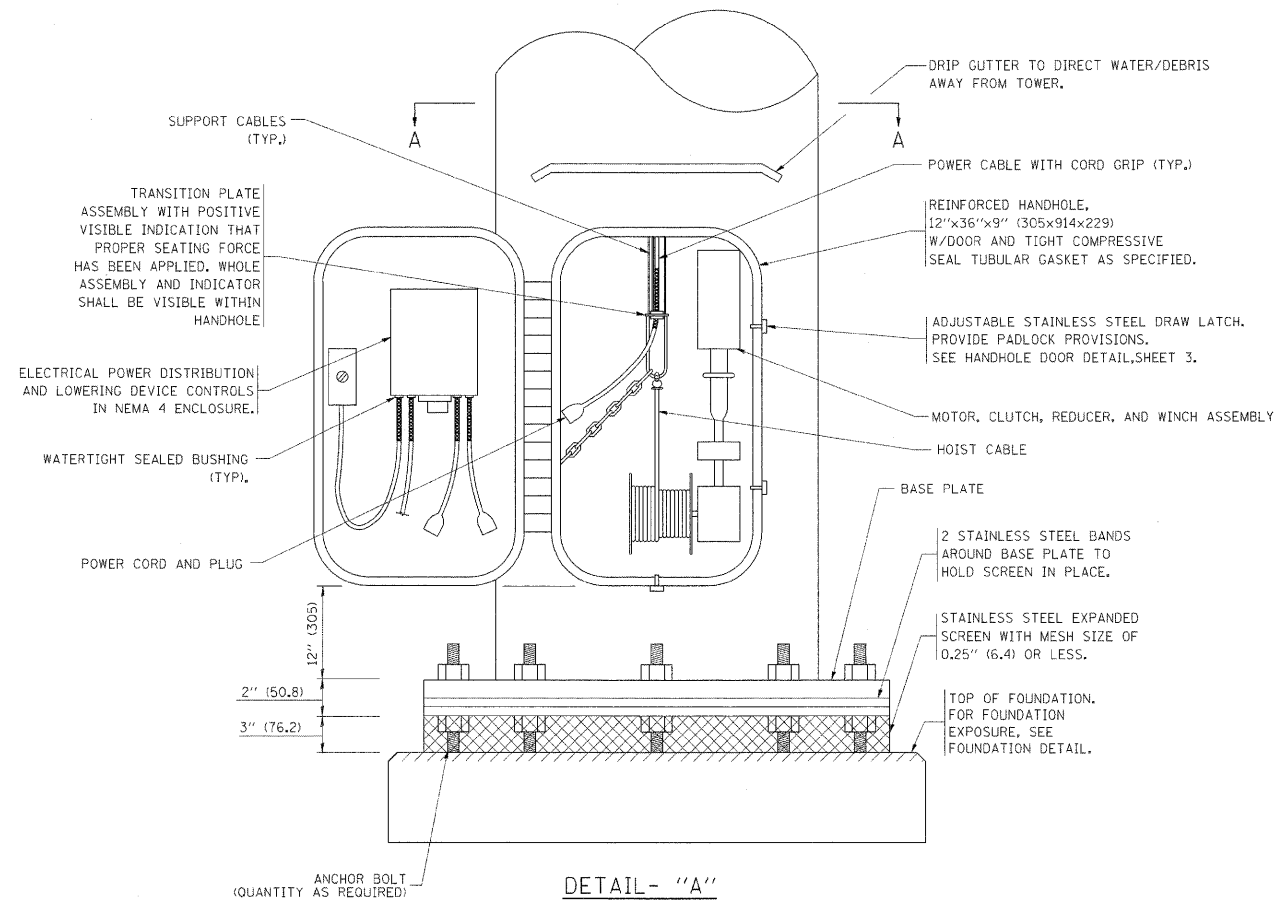
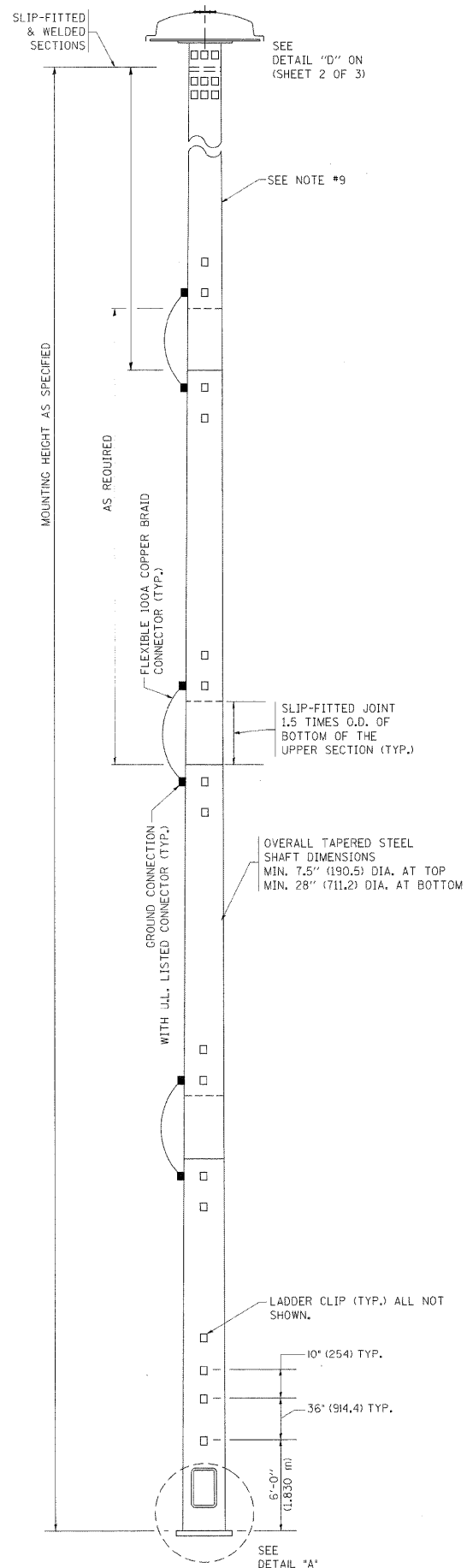

DETAIL - "A"

3 CABLE LOWERING & SUPPORT MECHANISM SHOWN.

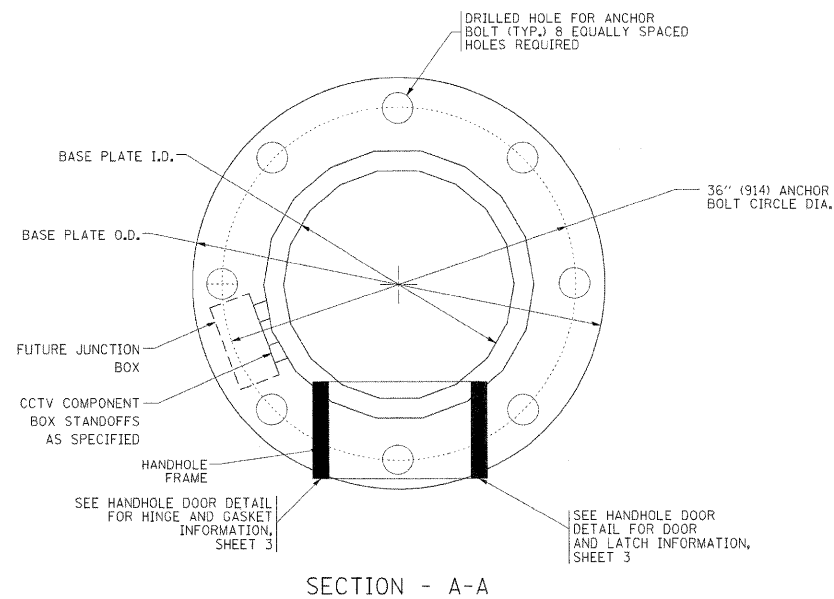

SECTION - A-A

NOTES:

1. ALL DIMENSIONS ARE IN INCHES (MILLIMETERS) UNLESS OTHERWISE SHOWN.
2. THE DESIGN SHALL BE BASED UPON AASHTO "STANDARD SPECIFICATIONS FOR STRUCTURAL SUPPORTS FOR HIGHWAY SIGNS, LUMINAIRES AND TRAFFIC SIGNALS" CURRENT AT THE TIME THE PROJECT IS ADVERTISED AND A TOTAL COMBINED LUMINAIRE WEIGHT OF 720 LBS. (326 kg) AND HAVING A TOTAL PROJECTED AREA OF 24 SQ. FT. (7.3 sq. m).
3. ALL TOWER SHAFT COMPONENTS, INCLUDING, BUT NOT LIMITED TO THE SHAFT SECTIONS, BASE PLATE, LADDER CLIPS, HANDHOLE DOOR, HANDHOLE REINFORCING, RAIN CUTTER, AND BASE PLATE, SHALL BE FABRICATED FROM HIGH-STRENGTH, LOW ALLOY, STEEL WITH A MINIMUM YIELD STRENGTH OF 50,000 PSI (345 K PA) ACCORDING TO AASHTO M 223 (ASTM A 572 GR50)
4. THE ELECTRIC MOTOR, MOTOR GEAR REDUCER, WINCH DRUM ASSEMBLY AND AUTOMATIC SHUTOFF SWITCH OF THE LOWERING DEVICE SHALL BE ACCESSIBLE FROM THE FRONT OF THE TOWER FOR EASY REMOVAL AND MAINTENANCE. ALL COMPONENTS SHALL BE REMOVABLE THROUGH THE HANDHOLE.
5. THE LIGHT TOWER SHAFT SHALL HAVE LADDER CLIPS. CLIPS SHALL BEGIN 6 FT. (1.8 m) ABOVE THE BASE PLATE WITH ALTERNATE 1.8 m (600) AND 10 INCH (250) SPACING THEREAFTER, FOR THE ENTIRE LENGTH. THE TOP 10 FT. (3 m) OF THE POLE SHAFT SHALL HAVE 3 SETS OF CLIPS. EACH SET OF CLIPS SHALL BE 120 DEGREES APART. CLIPS SHALL BE 0.25 X 2 INCHES (6 X 50) WELDED TO THE SHAFT TO PRODUCE A SLOT 0.625 INCHES (15.9) DEEP AND 1.625 INCHES (41.3) LONG. THE TOP INSIDE EDGE SHALL BE CHAMFERED.
6. A COPPER BONDING JUMPER SHALL BOND SLIP-FIT POLE SECTIONS TOGETHER WITH A FLAT COPPER MESH AND STAINLESS STEEL GROUND LUGS.
7. ALL TOWER SHAFT HARDWARE, SUCH AS GROUND LUGS, JUNCTION BOXES, HARDWARE FOR THE HANDHOLE DOOR, INCLUDING THE HANDLE/LATCH MECHANISM, HINGE AND DOOR STOP, SHALL BE STAINLESS STEEL. ALL CONDUIT AND CONDUIT FITTINGS SHALL BE PVC COATED GALVANIZED STEEL.
8. THE ENTIRE TOWER INCLUDING THE SHAFT, HANDHOLE, HANDHOLE DOOR, BASE PLATE AND ALL OTHER ELEMENTS WELDED TO THE SHAFT SHALL BE GALVANIZED IN ACCORDANCE WITH AASHTO M 111 (ASTM A 123) AND THEN PAINTED AS SPECIFIED. THE LUMINAIRE RING SHALL BE PRIMED AND PAINTED AS SPECIFIED.
9. THE FINISH COAT SHALL BE ANSI 70, SKY GREY COLOR SAMPLE TO BE SUBMITTED FOR APPROVAL.
10. ALL MULTI-CONDUCTOR CABLES SHALL BE FITTED WITH A HEAT-SHRINK MULTI-LEG BOOT. THE BOOT SHALL MEET MILITARY SPECIFICATION MIL-I-81765/1.
11. THE LIGHT TOWER SHALL BE STRAIGHT AND CENTERED ON ITS LONGITUDINAL AXIS, UNDER NO-WIND CONDITIONS, SO WHEN EXAMINED WITH A TRANSIT FROM ANY DIRECTION, THE DEVIATION FROM THE NORMAL SHALL NOT EXCEED 1/8 IN. IN 3 FT (2 mm IN 1 m) WITHIN ANY 5 FT (1.5 m) OF HEIGHT, WITH TOTAL DEVIATION NOT TO EXCEED 3 IN. (75) FROM THE VERTICAL AXIS THROUGH THE CENTER OF THE POLE BASE.
12. PVC CONDUIT WILL NOT BE ALLOWED FOR ANY LIGHT TOWER COMPONENT.
13. COUNTER WEIGHTS TO BE INCLUDED AS A PART OF THE LIGHT TOWER PAY ITEM.

FILE NAME = D:\0\F12-SHT-BE-505a.dgn

USER NAME = TKJuegel
 DESIGNED - IDOT
 DRAWN - CJM
 CHECKED - KMY
 PLOT DATE = 2/3/2011
 DATE = 2/4/11

REVISED -
 REVISED -
 REVISED -
 REVISED -

**STATE OF ILLINOIS
 DEPARTMENT OF TRANSPORTATION**

**HIGH MAST LIGHT TOWER
 120 FT TO 140 FT (36 m TO 43 m)**

SCALE: SHEET NO. 1 OF 3 SHEETS STA. TO STA.

F.A.I. RTE.	SECTION	COUNTY	TOTAL SHEETS	SHEET NO.
55	99-2HB-2B-1	WILL	756	430
CONTRACT NO. 60F12				
FED. ROAD DIST. NO. 1 ILLINOIS FED. AID PROJECT				

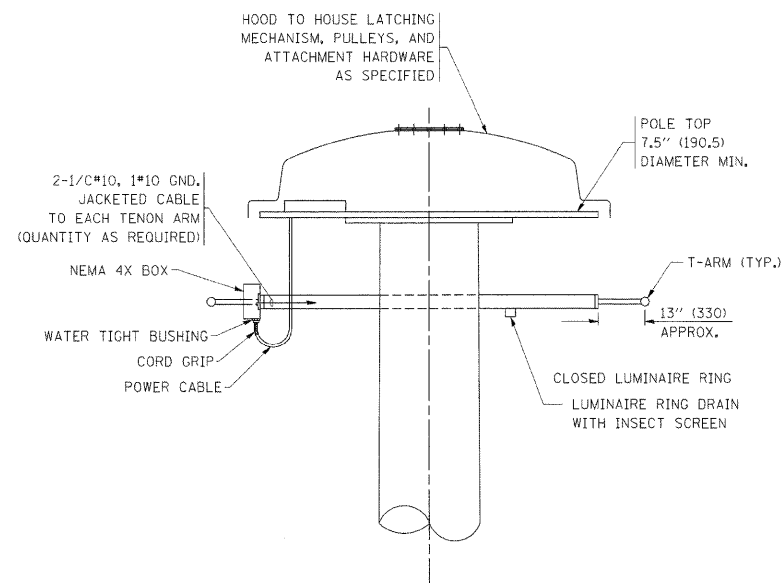

DETAIL - "D"

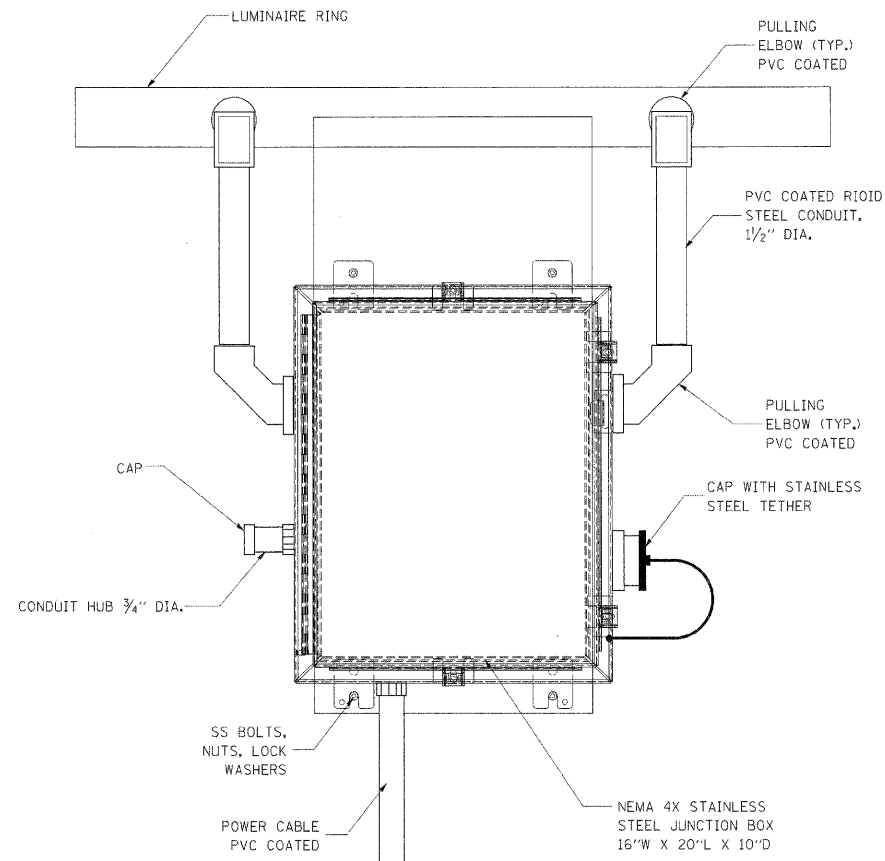

FRONT VIEW
N.T.S.

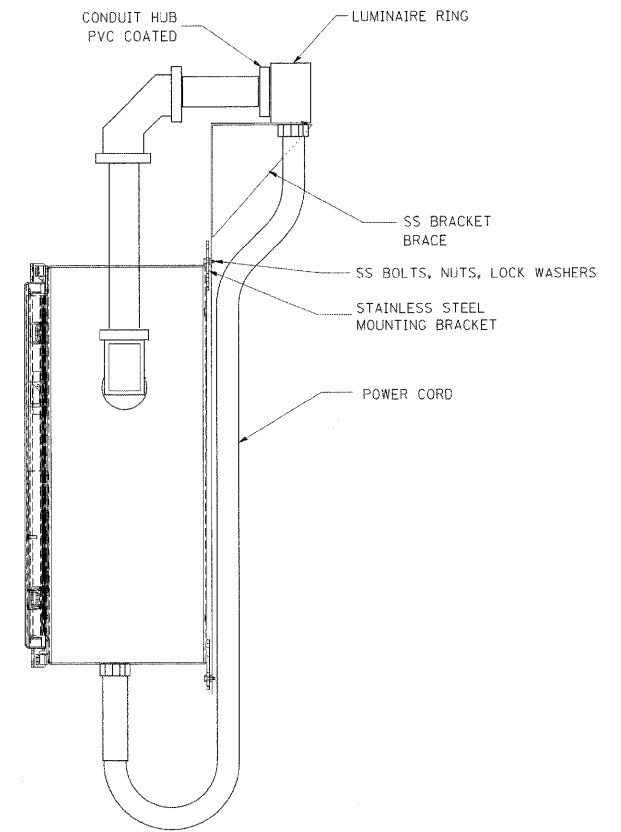

SIDE VIEW
N.T.S.

LUMINAIRE RING TERMINAL BOX

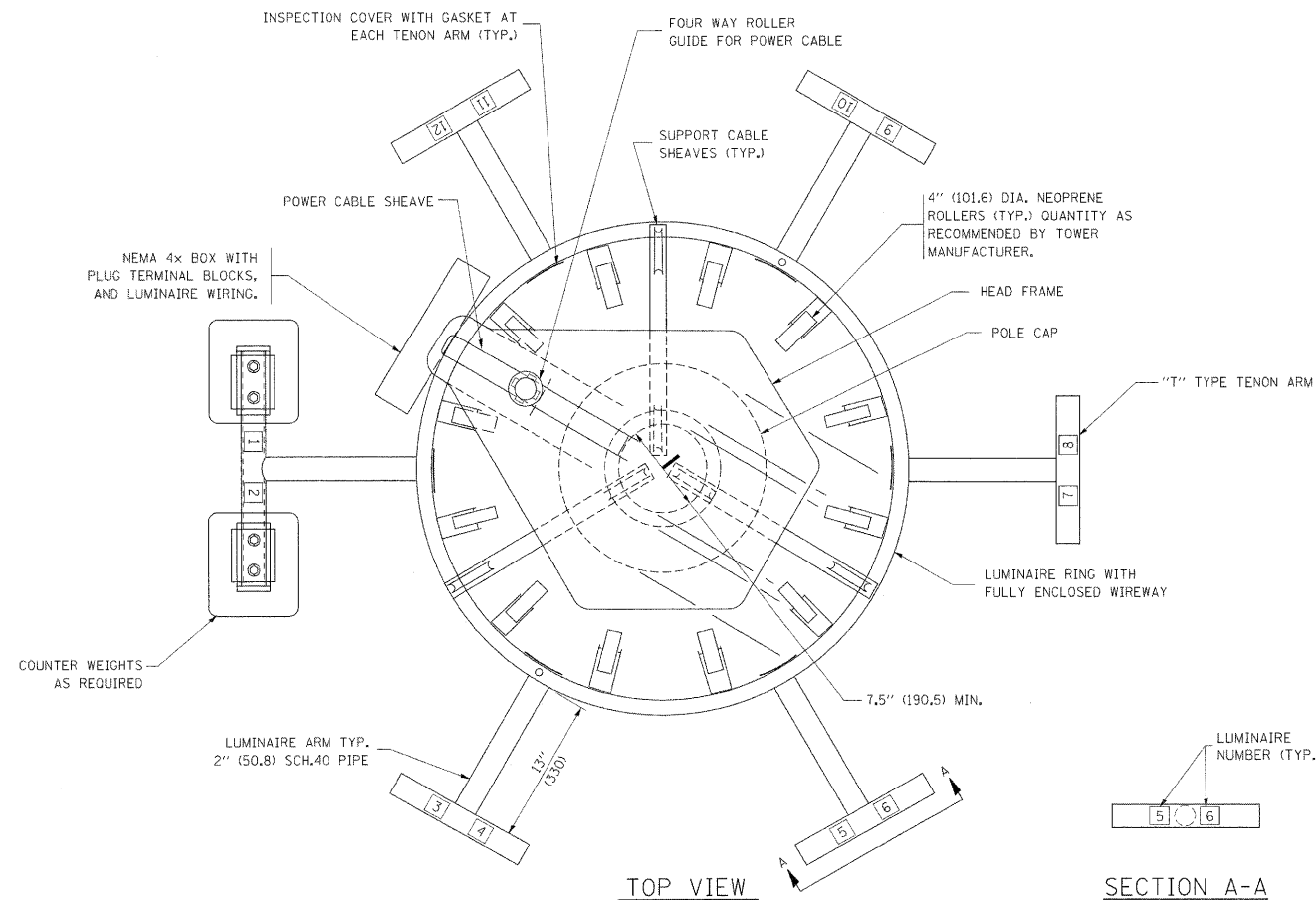

TOP VIEW

SECTION A-A

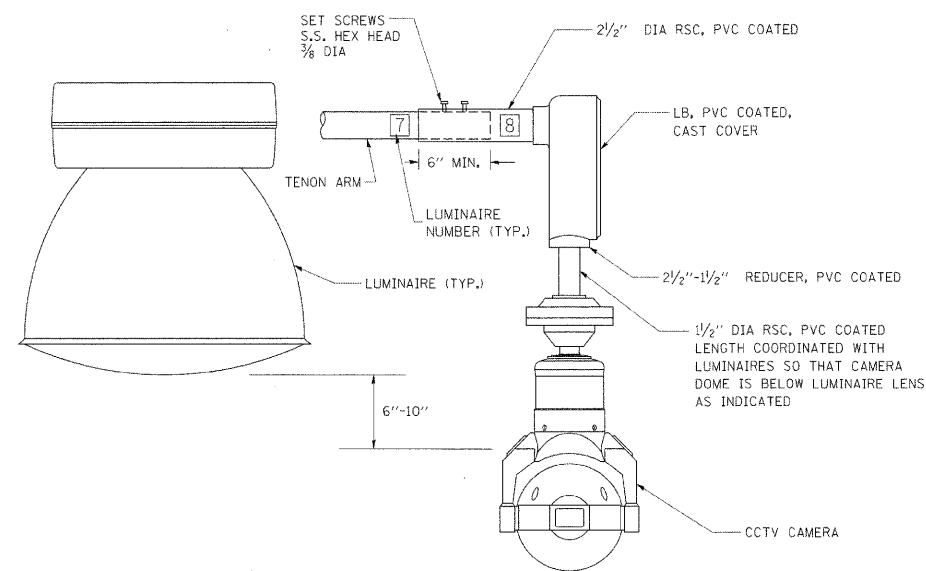

CCTV CAMERA MOUNTING DETAIL

NOTES:

- LUMINAIRE WIRES SHALL EXTEND 24 INCHES (609 mm) LONGER THAN THEIR RESPECTIVE TENON ARM AND SHALL BE TRAINED BACK INTO THE ARM WHICH SHALL THEN BE CLOSED WITH A CAP AS SPECIFIED. ALL WIRES SHALL BE CAPPED WITH HEAT SHRINK INSULATING BOOTS, CRIMP CAPS ARE UNACCEPTABLE. ALL RING WIRES SHALL BE TAGGED WITH WIRE MARKERS AT BOTH ENDS. THE TENON ARMS SHALL ALSO BE TAGGED CORRESPONDING TO THE WIRING CONTAINED WITHIN.
- SPLICING WILL NOT BE ALLOWED WITHIN THE LUMINAIRE RING.
- ALL TOWER SHAFT HARDWARE, SUCH AS GROUND LUGS, JUNCTION BOXES, HARDWARE FOR THE HANDHOLE DOOR, INCLUDING THE HANDLE/LATCH MECHANISM, HINGE AND DOOR STOP, SHALL BE STAINLESS STEEL. ALL CONDUIT AND CONDUIT FITTINGS SHALL BE PVC COATED GALVANIZED STEEL.
- ALL MULTI-CONDUCTOR CABLES SHALL BE FITTED WITH A HEAT-SHRINK MULTI-LEG BOOT. THE BOOT SHALL MEET MILITARY SPECIFICATION MIL-I-81765/1.

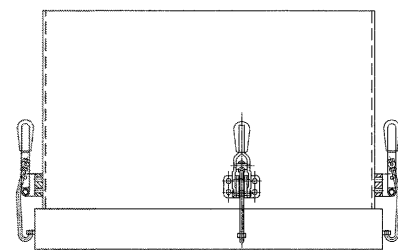

TOP VIEW

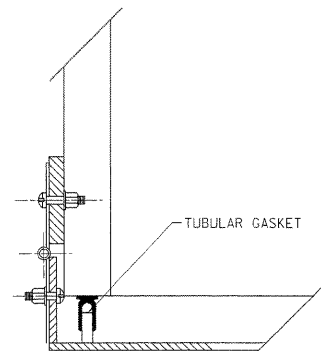

HINGE DETAIL

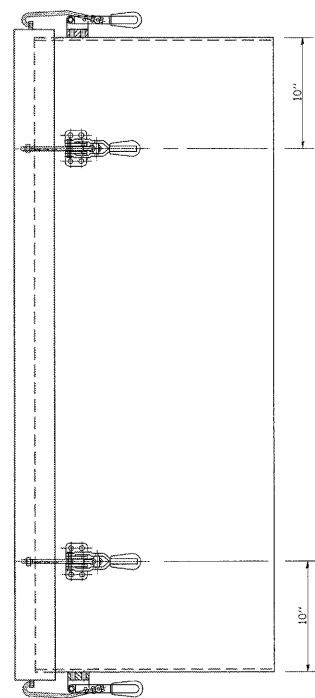

SIDE VIEW

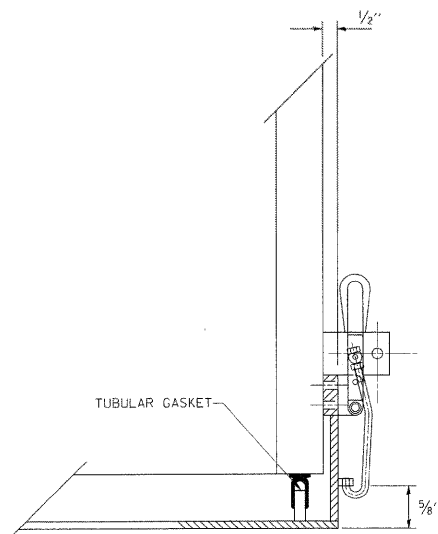

LATCH DETAIL

HANDHOLE DOOR DETAILS

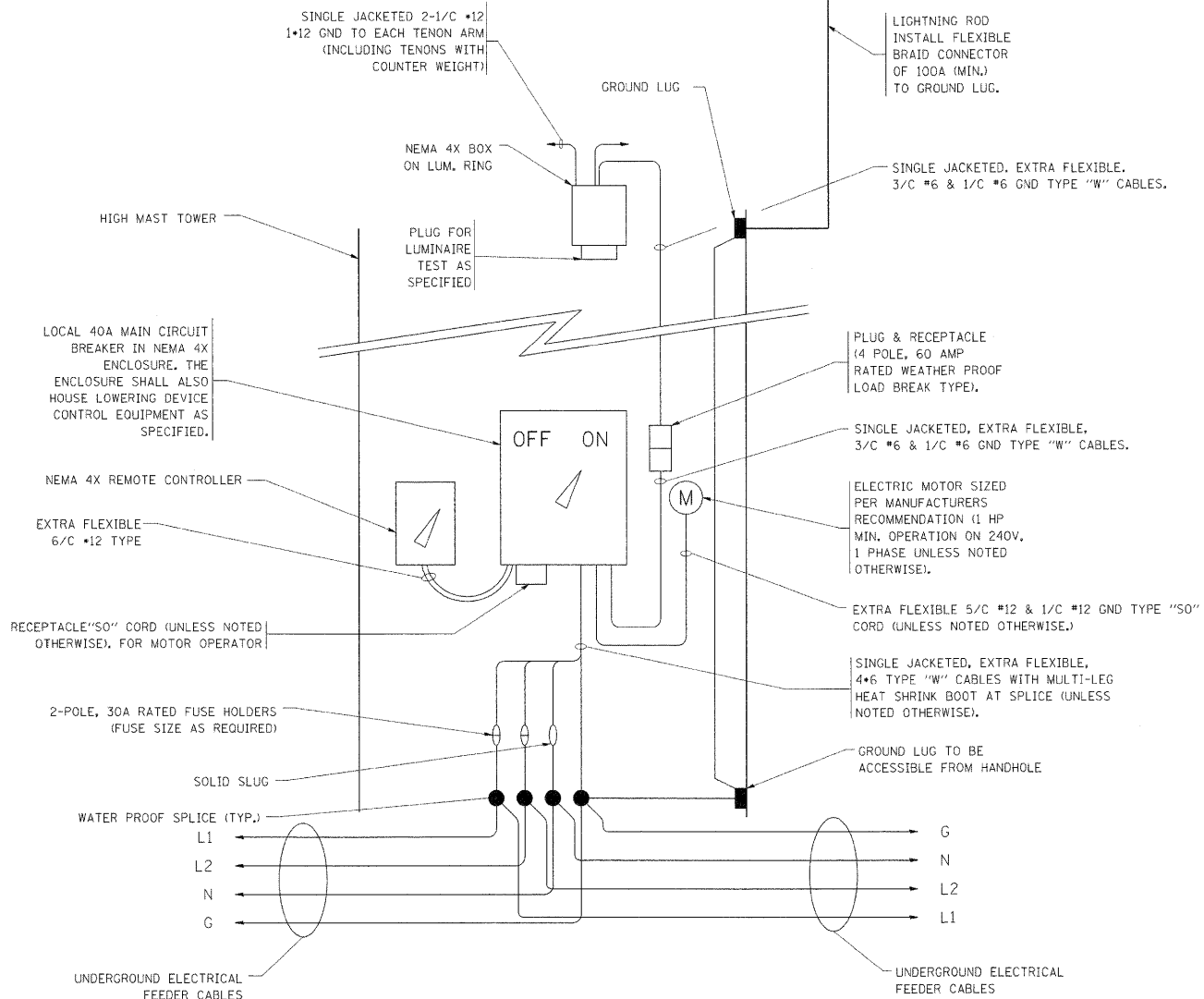

HIGH MAST POLE WIRING DIAGRAM

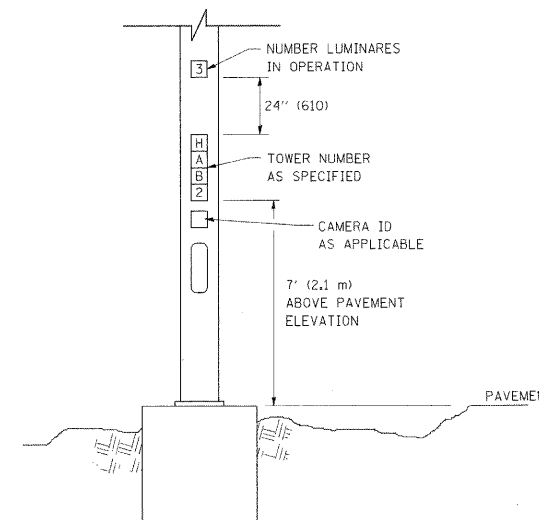

LIGHT TOWER NUMBERING DETAIL

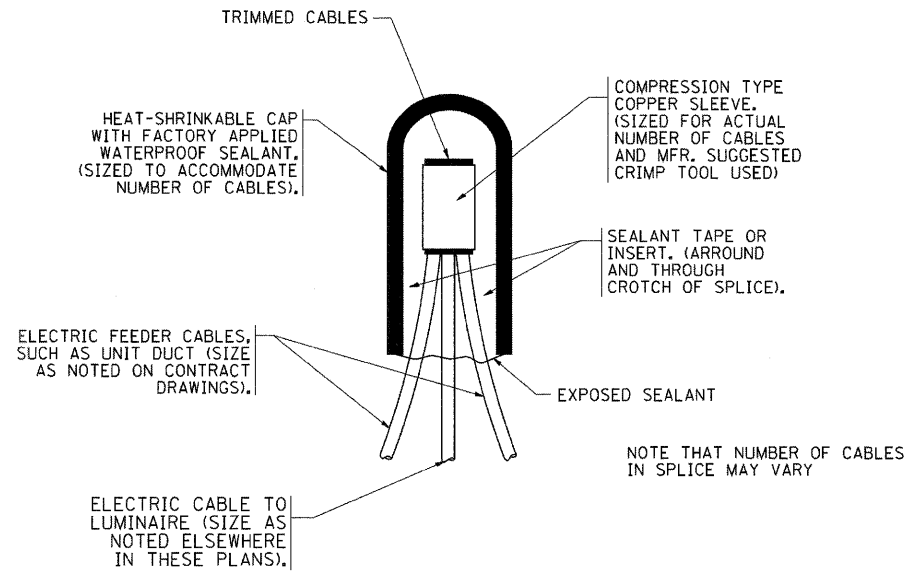

TYPICAL SPLICE DETAIL

N.T.S.

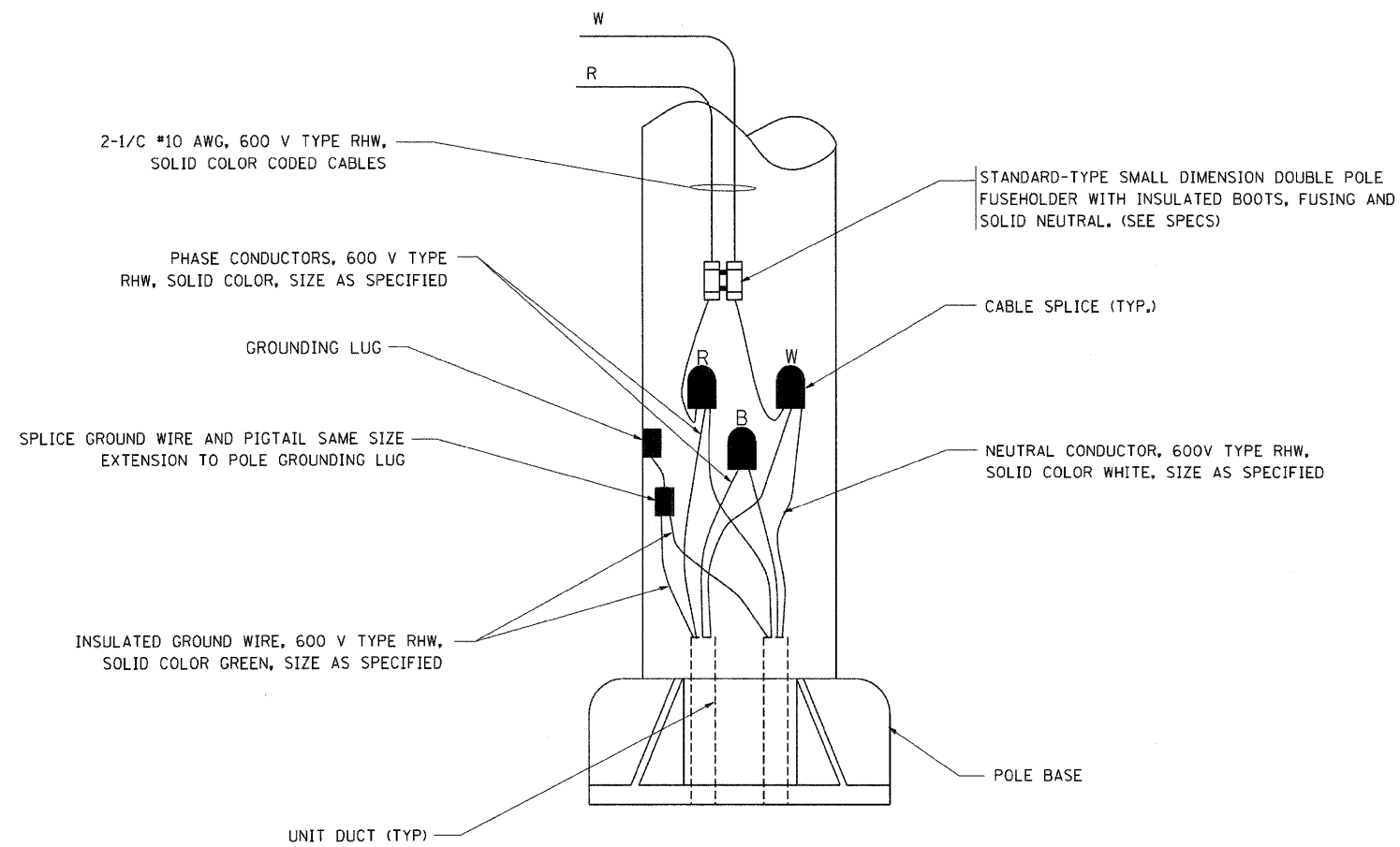

POLE WIRING DETAIL

N.T.S.

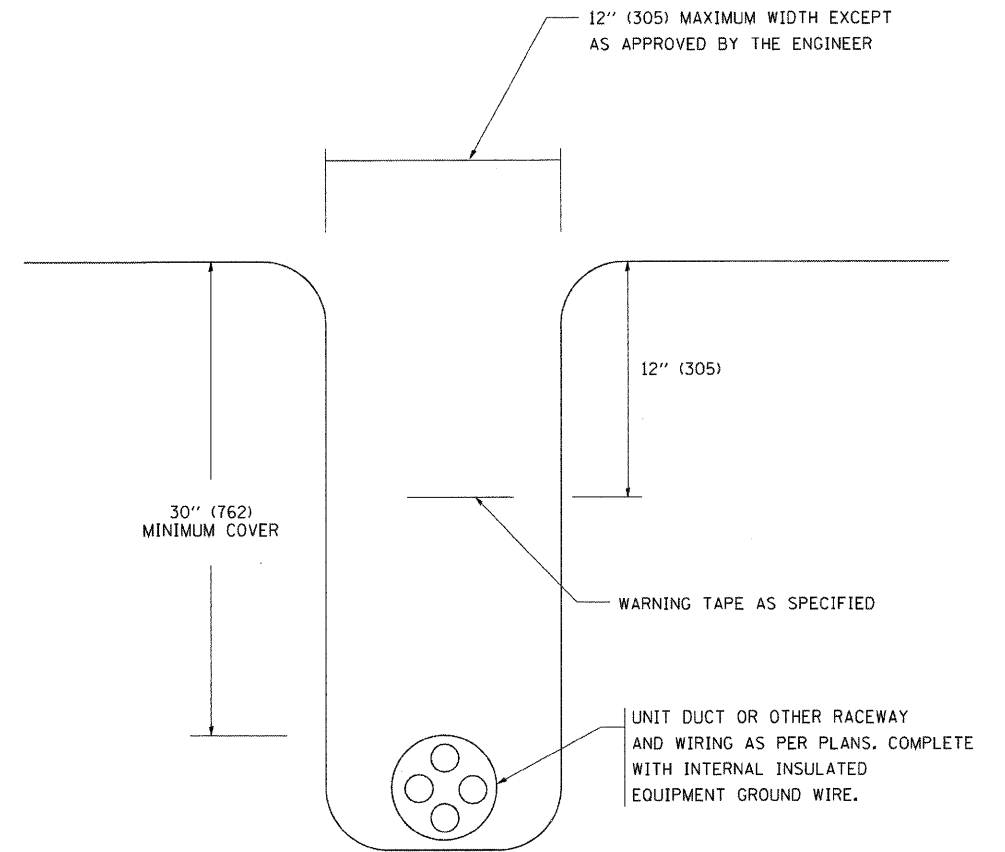

TYPICAL WIRING IN TRENCH DETAIL

N.T.S.

FILE NAME = D160F12-SHT-BE-702.dgn	USER NAME = TKluegel	DESIGNED - IDOT	REVISED -
		DRAWN - CJM	REVISED -
		CHECKED - KMY	REVISED -
		DATE - 2/4/11	REVISED -

F.A.I. RTE.	SECTION	COUNTY	TOTAL SHEETS	SHEET NO.
55	99-2HB-2B-1	WILL	756	433
CONTRACT NO. 60F12				
FED. ROAD DIST. NO. 1 ILLINOIS FED. AID PROJECT				

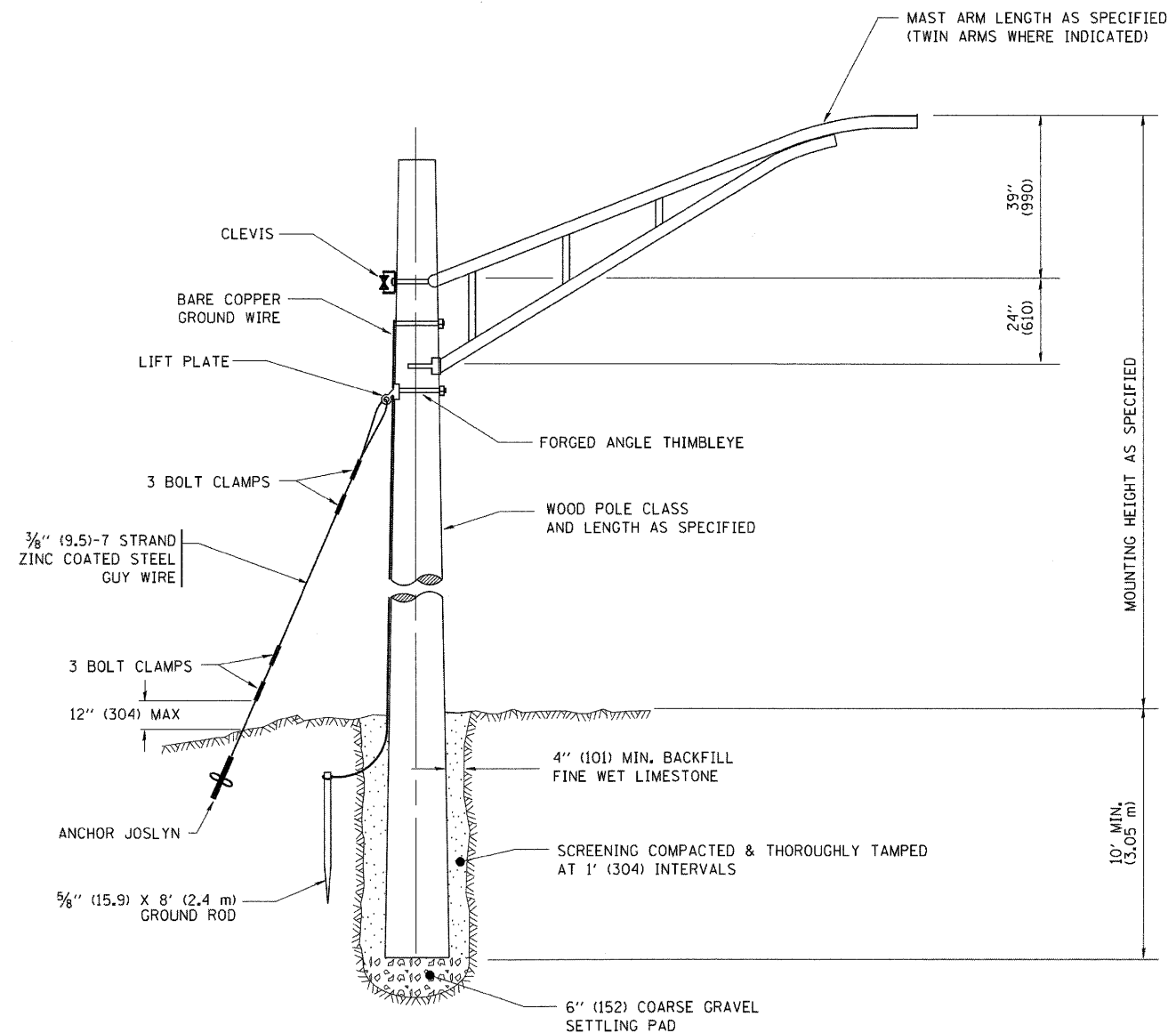

TEMPORARY LIGHT POLE DETAIL

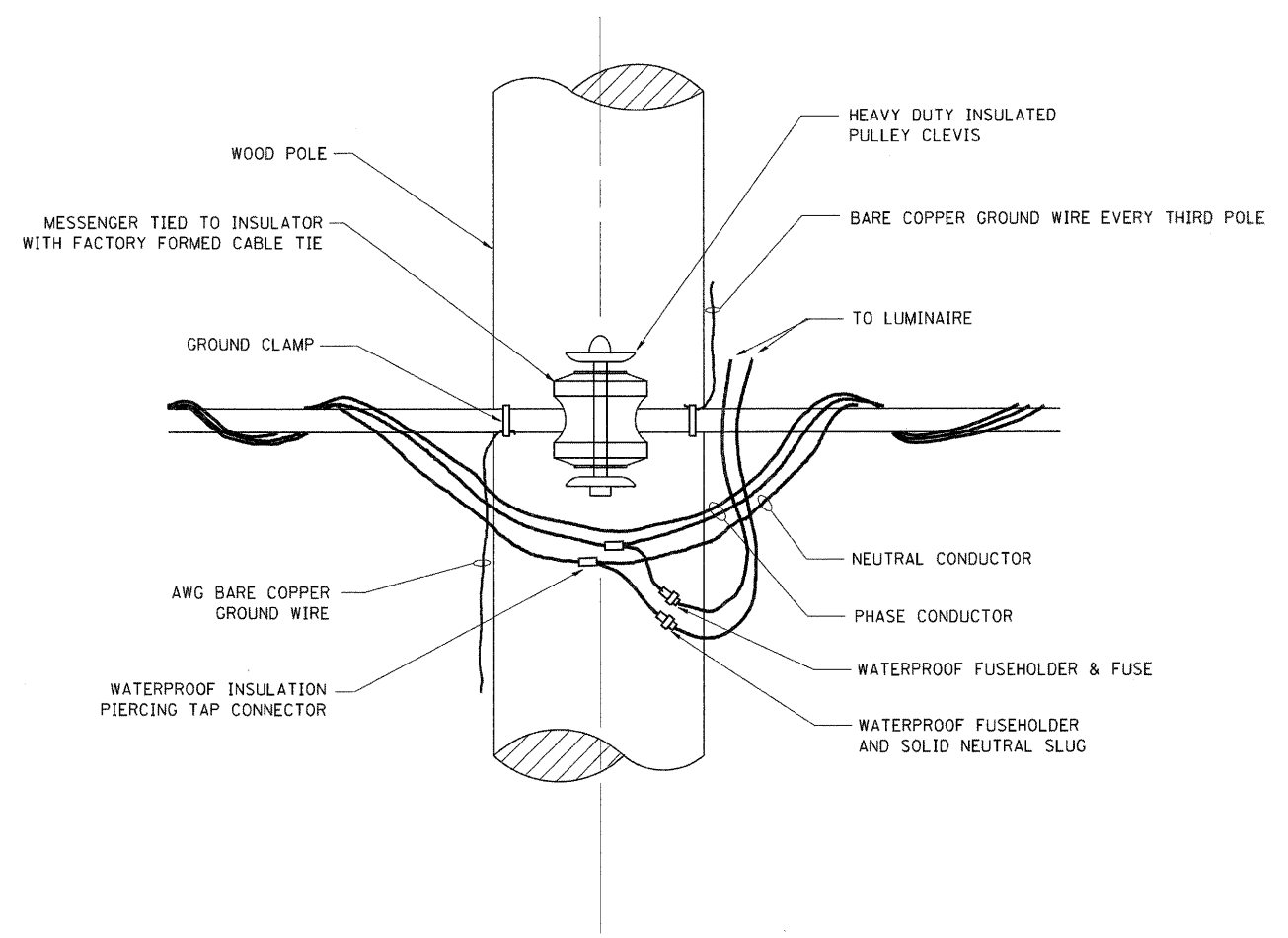

TEMPORARY LIGHT POLE ATTACHMENT DETAIL

MODIFICATIONS TO IDOT STANDARD:

1. CONTRACTOR SHALL AUGER A 30" DIA HOLE FOR EACH TEMPORARY POLE LOCATION. CLASS SI CONCRETE SHALL BE POURED AROUND THE POLE UP TO 6" BELOW GRADE. BACKFILL THE REMAINING DEPTH OF THE HOLE TO MATCH GRADE. THE COST OF CLASS SI CONCRETE, GROUND ROD, AND #6 COPPER GROUND WIRE SHALL BE INCLUDED IN THE COST OF "LIGHT POLE, WOOD, 100 FOOT, CLASS 1, WITH 15FT MAST ARM" PAY ITEM. SEPARATE PAYMENT WILL NOT BE MADE.
2. SEE DRAWING ED-6 FOR MAST ARM AND TEMPORARY LUMINAIRE INSTALLATION DETAILS.

NOTES:

1. ALL DIMENSIONS IN INCHES (MILLIMETERS) UNLESS OTHERWISE INDICATED

McDonough Associates Inc.
 Engineers / Architects
 130 East Randolph Street, Chicago, Illinois 60601

FILE NAME = D162F12-SHT-BE-800.dgn	USER NAME = TKIuegal	DESIGNED - IDOT	REVISED -	STATE OF ILLINOIS DEPARTMENT OF TRANSPORTATION	TEMPORARY LIGHT POLE DETAILS			F.A.I RTE. 55	SECTION 99-2HB-2B-1	COUNTY WILL	TOTAL SHEETS 756	SHEET NO. 434
PLOT SCALE = 1:1	CHECKED - KMY	DRAWN - CUM	REVISED -		SCALE:	SHEET NO. 1 OF 1 SHEETS	STA.	TO STA.	CONTRACT NO. 60F12			
PLOT DATE = 2/3/2011	DATE - 2/4/11	REVISOR -	REVISOR -		FED. ROAD DIST. NO. 1 ILLINOIS FED. AID PROJECT							

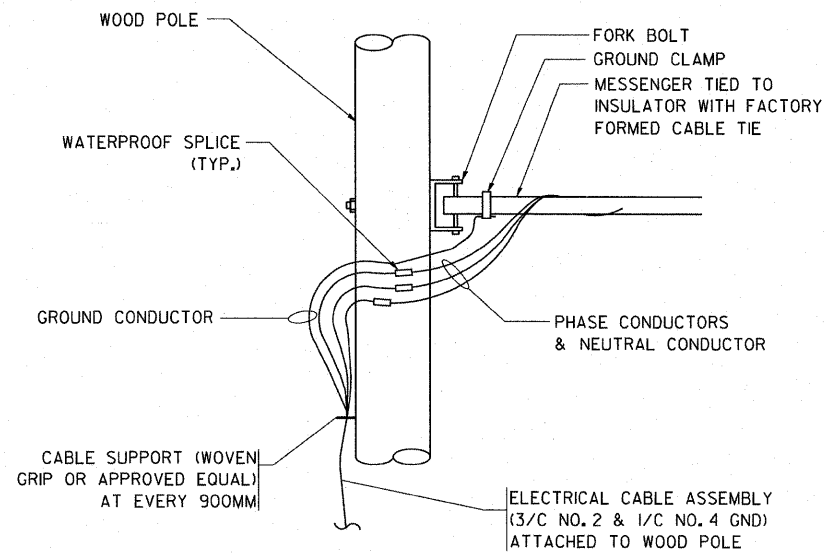

AERIAL CABLE CONNECTION DETAIL

N.T.S.

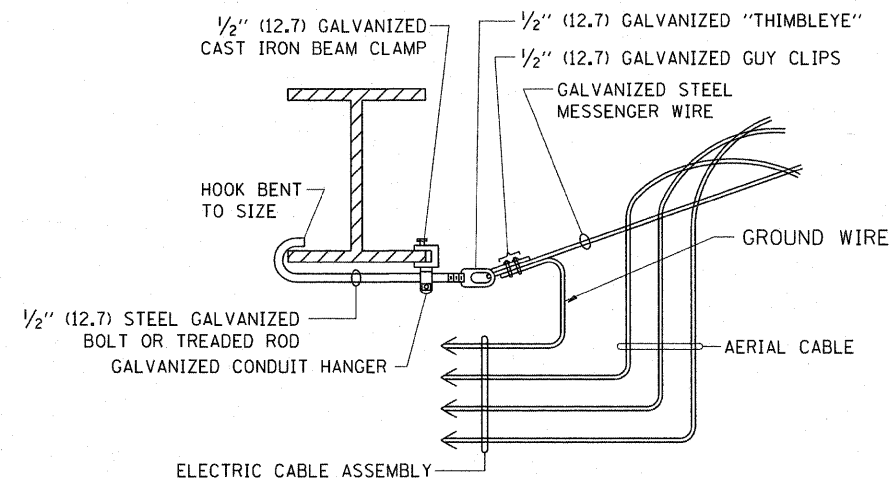

AERIAL CABLE ATTACHED TO STRUCTURE

NOT TO SCALE

NOTES:

1. ALL DIMENSIONS IN INCHES (MILLIMETERS) UNLESS OTHERWISE INDICATED.
2. SEE PROPOSED LIGHTING PLAN FOR CONDUIT, CABLE AND ROUTING.
3. THE CONTRACTOR SHALL PROVIDE INTERMEDIATE SUPPORTS TO MAINTAIN MINIMUM CLEARANCES. REFER TO AERIAL AERIAL CABLE ATTACHED TO STRUCTURE DETAIL.
4. COST OF SPLICES AND MOUNTING HARDWARE SHALL BE INCLUDED IN THE UNIT PRICE FOR AERIAL CABLE.
5. THE COST OF 2" PVC CONDUIT ATTACHED TO POLE SHALL BE INCLUDED IN THE COST OF "LIGHT POLE, WOOD, 60 FOOT, CLASS 4 (INSTALL ONLY)" PAY ITEM. SEPARATE PAYMENT WILL NOT BE MADE.

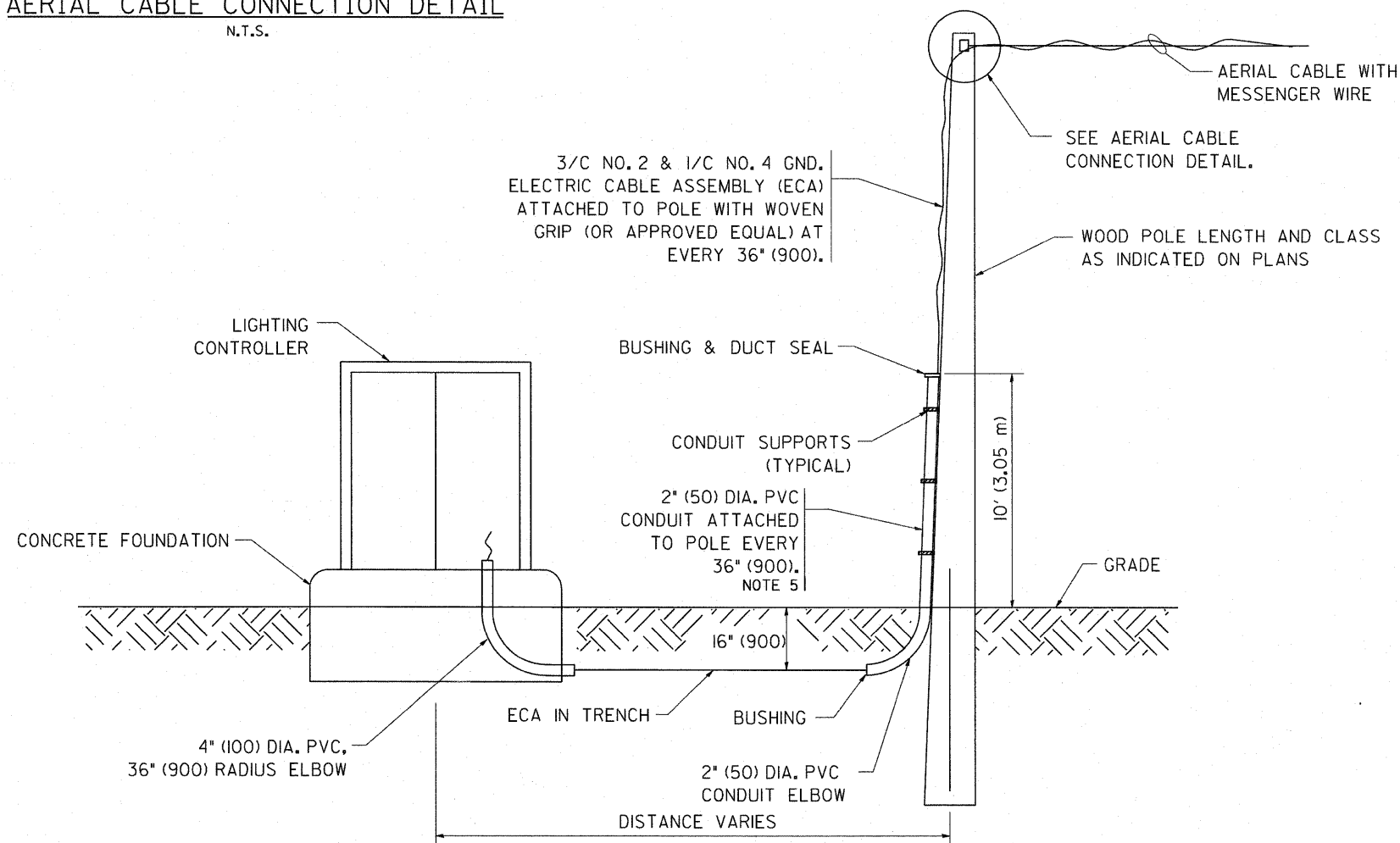

WOOD POLE TO LIGHTING CONTROLLER WIRING CONNECTION DETAIL

N.T.S.

FILE NAME =	USER NAME = TKJuegel
D160F12-SHT-BE-801.cgn	
PLOT SCALE = 1:1	
PLOT DATE = 3/3/2011	

DESIGNED -	IDOT	REVISED -	
DRAWN -	CJM	REVISED -	
CHECKED -	KMY	REVISED -	
DATE -	2/4/11	REVISED -	

STATE OF ILLINOIS
DEPARTMENT OF TRANSPORTATION

STATE OF ILLINOIS	
DEPARTMENT OF TRANSPORTATION	

TEMPORARY AERIAL CABLE INSTALLATION	
SCALE:	SHEET NO. 1 OF 1 SHEETS
STA.	TO STA.

F.A.I. RTE.	SECTION	COUNTY	TOTAL SHEETS	SHEET NO.
55	99-2HB-2B-1	WILL	756	435
FED. ROAD DIST. NO. 1			ILLINOIS FED. AID PROJECT	
			CONTRACT NO. 60F12	

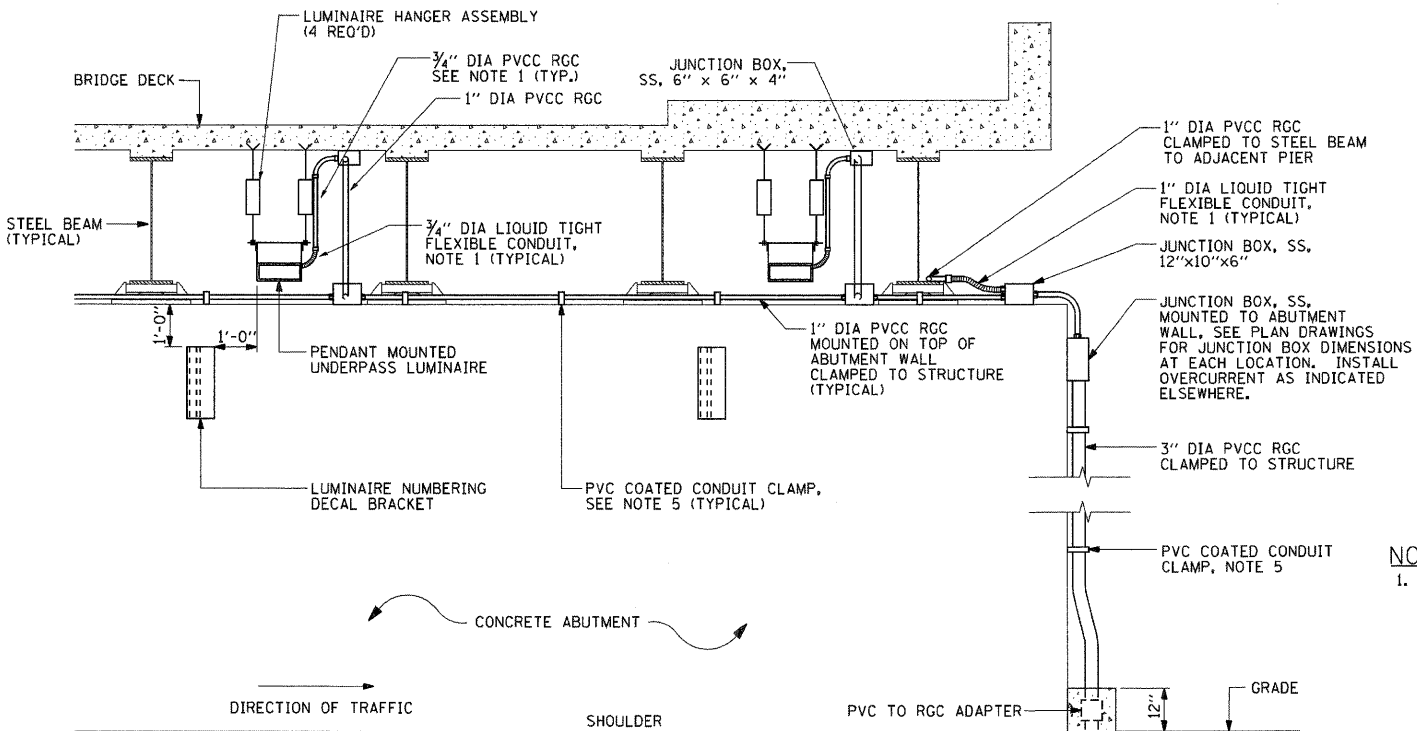
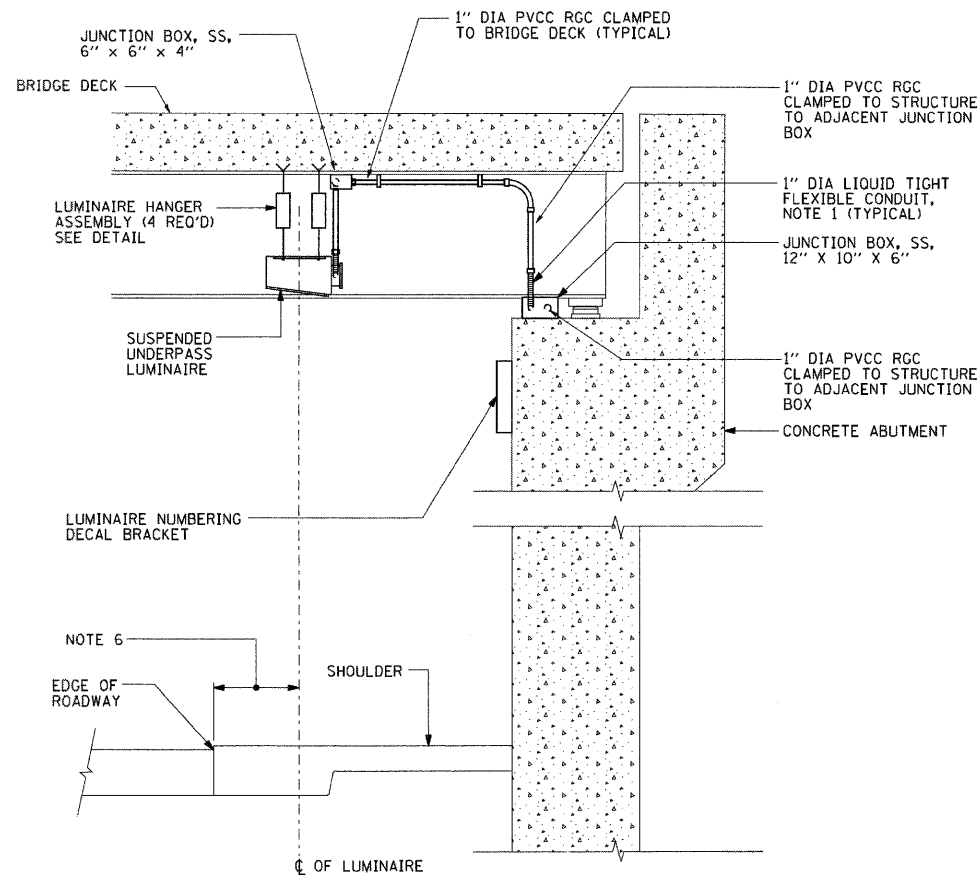

NOTES:

1. LIQUID TIGHT FLEXIBLE METAL CONDUIT, MAXIMUM LENGTH 6'-0", TYPICAL FOR EACH INSTANCE AS SHOWN, PROVIDE PVC COATED RIGID GALVANIZED STEEL CONDUIT AS REQUIRED NOT TO EXCEED 6'-0" OF FLEXIBLE LIQUID TIGHT METAL CONDUIT. LIQUID TIGHT FLEXIBLE METAL CONDUIT WILL BE INCLUDED IN THE COST OF THE CONDUIT ATTACHED TO STRUCTURE, OF THE CORRESPONDING DIA., GALVANIZED STEEL, PVC COATED PAY ITEM EXCEPT THAT 3/4" DIA. CONDUIT AND 3/4" DIA. FLEXIBLE CONDUIT SHALL BE INCLUDED IN THE COST OF UNDERPASS LUMINAIRE INSTALLATION.
2. SEE UNDERPASS LIGHTING PLANS FOR INSTALLATION LOCATION OF UNDERPASS LIGHTING LUMINAIRES.
3. THE CONTRACTOR SHALL USE APPROVED SINGLE COIL FLARED LOOP INSERTS WHEN SUSPENDED MOUNTING AN UNDERPASS LUMINAIRE TO A NEW BRIDGE DECK. THE FLARED LOOP INSERTS MUST BE CAST INTO THE CONCRETE DECK. THE CONTRACTOR IS RESPONSIBLE FOR LOCATING AND COORDINATING THE INSERT LOCATIONS FOR MOUNTING THE UNDERPASS LIGHTING SYSTEM AS SHOWN ON THE PLANS WITH THE BRIDGE DECK CONTRACTOR, SEE DETAIL.
4. THE UNDERPASS LUMINAIRE HANGER ASSEMBLY COMPLETE WITH HEAVY DUTY ANCHORS/INSERTS AND ALL APPLICABLE HARDWARE SHALL BE INCLUDED IN THE COST OF THE UNDERPASS LUMINAIRE PAY ITEM.
5. SECURE THE CONDUIT WITH PVC COATED CONDUIT CLAMPS OR CONDUIT BEAM CLAMPS AS SHOWN AT 5'-0" INTERVALS FOR LATERALS AND WITHIN 2'-0" MAXIMUM FROM ANY JUNCTION BOX, FLEXIBLE CONDUIT, OR CHANGE IN DIRECTION. ALL PVC COATED CONDUIT CLAMPS OR BEAM CLAMPS SHALL BE INCLUDED WITH THE COST OF THE "CONDUIT ATTACHED TO STRUCTURE, OF THE CORRESPONDING DIA., GALVANIZED STEEL, PVC COATED" PAY ITEM.
6. ALL UNDERPASS LUMINAIRES MUST BE CENTERED IN THE BEAM SPACE AS INDICATED ON THE PLANS UNLESS OTHERWISE DIRECTED BY THE ENGR. LUMINAIRE SETBACK SHALL BE AS INDICATED IN PLANS FOR EACH SPECIFIC UNDERPASS
7. THE CONCRETE ENCASED CONDUIT TRANSITION SHALL BE INCLUDED IN THE COST OF THE GALVANIZED RIGID STEEL CONDUIT PAY ITEMS.
8. ALL CONDUIT ATTACHED TO STRUCTURE SHALL BE PVC COATED RIGID STEEL CONDUIT (PVCC RGC) TYPICAL.

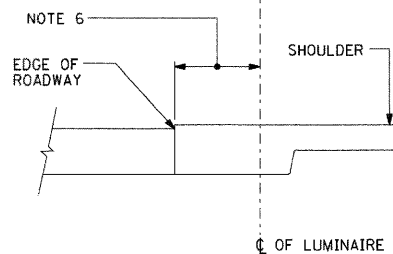

DIRECTION OF TRAFFIC

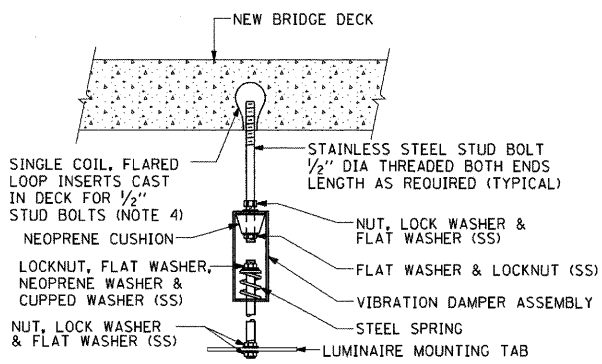
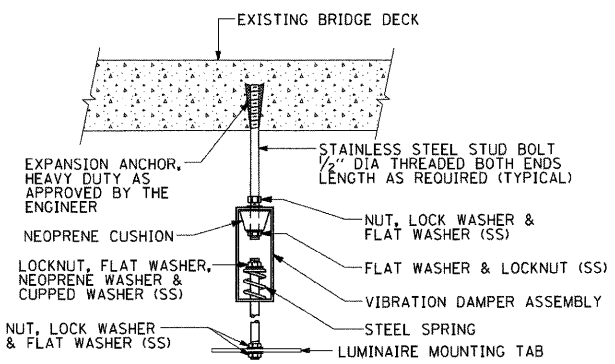
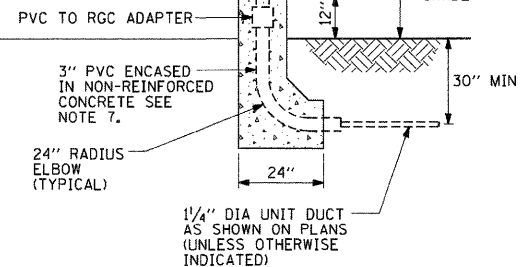

EXISTING BRIDGE DECK INSTALLATION

NEW BRIDGE DECK INSTALLATION

TYPICAL LUMINAIRE HANGER ASSEMBLY DETAILS

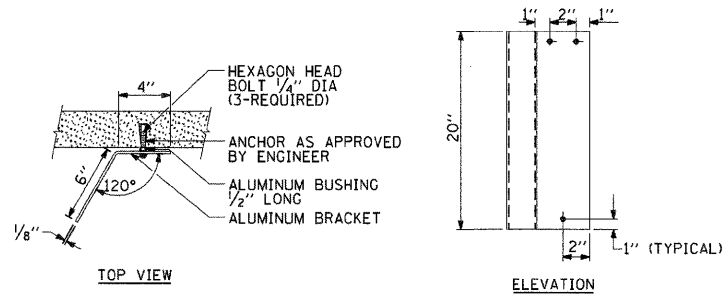

LUMINAIRE NUMBERING DECAL BRACKET
NOT TO SCALE

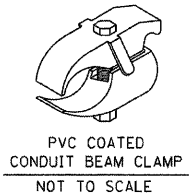

FILE NAME =	USER NAME = TKLuegel	DESIGNED - IDOT	REVISED -
D:\B\F12-SHT-BE-920.dgn		DRAWN - CJM	REVISED -
		CHECKED - KMY	REVISED -
		DATE - 2/4/11	REVISED -

STATE OF ILLINOIS
 DEPARTMENT OF TRANSPORTATION

SUSPENDED MOUNT UNDERPASS
 LUMINAIRE INSTALLATION DETAILS

SCALE: SHEET NO. 1 OF 1 SHEETS STA. TO STA.

F.A.I. RTE.	SECTION	COUNTY	TOTAL SHEETS	SHEET NO.
55	99-2HB-2B-1	WILL	756	436
CONTRACT NO. 60F12				
FED. ROAD DIST. NO. 1 ILLINOIS FED. AID PROJECT				

FOUNDATION ON WALL TABLE

Sheet No. Lighting Plans	Tower Designation	Location per Lighting Plans			Tower Height (ft.)	E. Gutter Elevation	W. Gutter Elevation	T/Rock Elevation	Top of Caisson Elevation	Bottom of Caisson Elevation	Top of Concrete Elevation	H (ft.)	L (ft.)	Rock Excavation (Cu. Yd.)	4" Conduit Stubs				Luminaire Orientations (Note 1)
		Roadway	Station	Offset											N	S	E	W	
RL-5	3 AEF4	RAMP B	3046+81.00	30.51 RT	120	537.21	533.25	530.82	531.25	518.25	540.71	9.46	13.00	7.40	1	2			2, 2, 182
RL-8	3 AEF5	ARSENAL	904+95.00	45.25 LT	120	537.60	534.39	531.61	532.39	519.39	541.10	8.71	13.00	7.20	1	2			2, 2, 182
RL-8	2 AEF6	ARSENAL	909+95.00	45.25 LT	120	539.10	534.88	530.90	532.88	518.88	542.60	9.72	14.00	7.08	1	2			2, 182
RL-8	2 AEF7	ARSENAL	914+95.00	42.25 LT	120	540.60	536.43	532.15	534.43	520.43	544.10	9.67	14.00	6.90	1	2			2, 182
RL-9	2 TEF7	ARSENAL	919+95.00	42.25 LT	120	542.10	540.38	536.50	538.38	525.38	545.60	7.22	13.00	6.55	2	1			2, 182
RL-9	2 TEF8	ARSENAL	924+95.00	42.25 LT	120	543.60	541.43	539.05	539.43	526.43	547.10	7.67	13.00	7.43	2	1			2, 182
RL-9	2 TEF6	ARSENAL	929+95.00	42.25 LT	120	545.10	542.68	539.88	540.68	527.68	548.60	7.92	13.00	7.19	2	1			2, 182
RL-10	2 TEF5	ARSENAL	934+95.00	42.25 LT	120	546.60	543.57	540.78	541.57	528.57	550.10	8.53	13.00	7.19	2	1			2, 182
RL-10	2 TEF4	ARSENAL	939+95.00	42.25 LT	120	552.64	550.04	547.12	548.04	535.04	556.14	8.10	13.00	7.12	2	1			2, 182
RL-10	2 TEF3	ARSENAL	944+45.00	42.25 LT	120	554.86	550.82	549.10	548.82	534.82	558.36	9.54	14.00	8.41	2	1			2, 182
RL-11	2 TEF2	ARSENAL	948+95.00	42.25 LT	120	553.45	549.09	547.69	547.09	533.09	556.95	9.86	14.00	8.60	2	1			2, 182
RL-1	2 AAB5	WFR	5000+73.00	45.57 RT	120	523.05	523.05	518.67	521.05	505.05	526.55	5.50	16.00	8.02	2	1			2, 2
RL-2	2 AST4	EFR	8008+89.00	37.78 LT	120	523.65	523.65	517.34	521.65	505.65	527.15	5.50	16.00	6.89	2	1			182, 182
RL-2	3 AST3	EFR	8012+90.00	24.91 LT	120	528.03	525.85	522.59	523.85	508.85	531.53	7.68	15.00	8.09	2	1			182, 182, 182
RL-2	2 AAB4	WFR	5005+80.00	35.43 RT	120	523.9	523.9	517.6	521.90	505.90	527.40	5.50	16.00	6.89	2	1			2, 2
RL-2	3 AAB3	WFR	5009+80.00	27.43 RT	120	526.05	526.05	522.20	524.05	509.05	529.55	5.50	15.00	7.75	2	1			2, 2, 2
RL-2	3 AAB2	WFR	5014+40.00	52.93 RT	120	529.43	529.43	526.72	527.43	513.43	532.93	5.50	14.00	7.83			2	1	2, 2, 182
RL-8	2 ACD10	WFC	6027+51.00	49.75 RT	120	535.19	535.19	530.66	533.19	517.19	538.69	5.50	16.00	7.93	1	2			2, 182
RL-8	2 ACD11	WFC	6032+50.00	39.84 RT	120	536.77	536.77	532.42	534.77	518.77	540.27	5.50	16.00	8.04		2			2, 182
RL-9	2 TAB7	WFC	6037+50.00	39.84 RT	120	540.67	540.67	537.23	538.67	523.67	544.17	5.50	15.00	7.99	2	1			2, 182
RL-9	2 TAB6	WFC	6042+50.00	43.91 RT	120	541.96	541.96	539.30	539.96	525.96	545.46	5.50	14.00	7.86	2	1			2, 182
RL-9	2 TAB5	WFC	6047+50.00	52.14 RT	120	542.79	542.79	540.21	540.79	526.79	546.29	5.50	14.00	7.90	2	1			2, 182
RL-10	2 TAB4	WFC	6052+50.00	51.94 RT	120	543.89	543.89	539.45	541.89	525.89	547.39	5.50	16.00	7.99	2	1			2, 182
RL-10	2 TAB3	WFC	6057+50.00	50.69 RT	120	550.36	550.36	544.18	548.36	532.36	553.86	5.50	16.00	6.96	2	1			2, 182
RL-10	2 TAB2	WFC	6061+99.00	49.44 RT	120	553.76	553.76	547.38	551.76	535.76	557.26	5.50	16.00	6.84	2	1			2, 182
RL-11	2 TAB1	WFC	6066+48.00	48.47 RT	120	552.59	552.59	546.23	550.59	534.59	556.09	5.50	16.00	6.86	2	1			2, 182

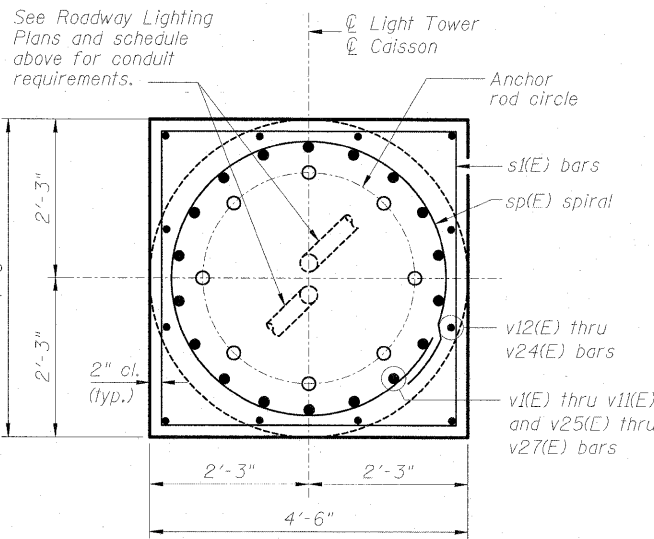
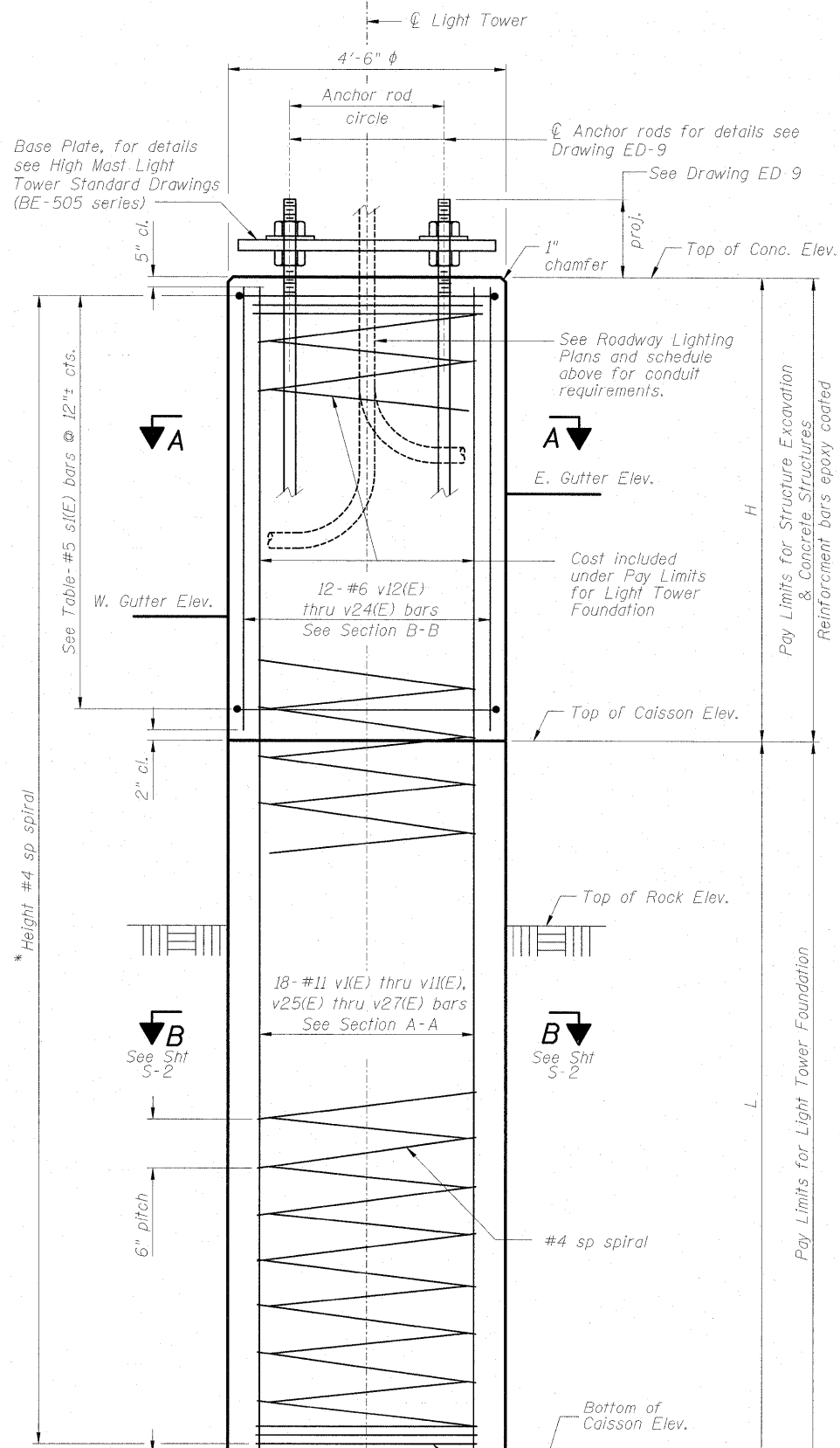

SECTION A-A
SCALE: NTS

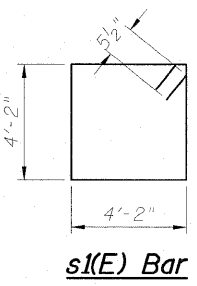

BILL OF MATERIAL

Tower 3 AEF4				Tower 3 AEF5				Tower 2 AEF6				Tower 2 AEF7				Shape
Bar	No.	Size	Length	Bar	No.	Size	Length	Bar	No.	Size	Length	Bar	No.	Size	Length	Shape
sp1(E)	1	#4	*21'-7 1/2"	sp2(E)	1	#4	*20'-10 1/2"	sp3(E)	1	#4	*22'-10 1/2"	sp4(E)	1	#4	*22'-10"	WWW
s1(E)	10	#5	17'-7"	s1(E)	9	#5	17'-7"	s1(E)	10	#5	17'-7"	s1(E)	10	#5	17'-7"	□
v1(E)	18	#11	21'-7 1/2"	v2(E)	18	#11	20'-10 1/2"	v3(E)	18	#11	22'-10 1/2"	v4(E)	18	#11	22'-10"	—
v12(E)	12	#6	8'-10 1/2"	v13(E)	12	#6	8'-1 1/2"	v14(E)	12	#6	9'-1 1/2"	v15(E)	12	#6	9'-1"	—

Tower 2 TEF8				Tower 2 TEF7				Tower 2 TEF6				Tower 2 TEF5				Shape
Bar	No.	Size	Length	Bar	No.	Size	Length	Bar	No.	Size	Length	Bar	No.	Size	Length	Shape
sp5(E)	1	#4	*19'-4 1/2"	sp6(E)	1	#4	*19'-10"	sp7(E)	1	#4	*20'-1"	sp8(E)	1	#4	*20'-8"	WWW
s1(E)	8	#5	17'-7"	s1(E)	8	#5	17'-7"	s1(E)	9	#5	17'-7"	s1(E)	9	#5	17'-7"	□
v5(E)	18	#11	19'-4 1/2"	v6(E)	18	#11	19'-10"	v7(E)	18	#11	20'-1"	v8(E)	18	#11	20'-8"	—
v16(E)	12	#6	6'-7 1/2"	v17(E)	12	#6	7'-1"	v18(E)	12	#6	7'-4"	v19(E)	12	#6	7'-11"	—

Tower 2 TEF4				Tower 2 TEF3				Tower 2 TEF2				Tower 3 AST3				Shape
Bar	No.	Size	Length	Bar	No.	Size	Length	Bar	No.	Size	Length	Bar	No.	Size	Length	Shape
sp9(E)	1	#4	*20'-3"	sp10(E)	1	#4	*22'-8 1/2"	sp11(E)	1	#4	*23'-0"	sp12(E)	1	#4	*21'-10"	WWW
s1(E)	9	#5	17'-7"	s1(E)	10	#5	17'-7"	s1(E)	11	#5	17'-7"	s1(E)	8	#5	17'-7"	□
v9(E)	18	#11	20'-3"	v10(E)	18	#11	22'-8 1/2"	v11(E)	18	#11	23'-0"	v25(E)	18	#11	21'-10"	—
v20(E)	12	#6	7'-6"	v21(E)	12	#6	8'-11 1/2"	v22(E)	12	#6	9'-3"	v24(E)	12	#6	7'-1"	—

Tower 2 AAB5, 2 AST4, 2 AAB4, 2 ACD10, 2 ACD11, 2 TAB4, 2 TAB3, 2 TAB2, 2 TAB1				Tower 3 AAB3, 2 TAB7				Tower 3 AAB2, 2 TAB6, 2 TAB5				Shape
Bar	No.	Size	Length	Bar	No.	Size	Length	Bar	No.	Size	Length	Shape
sp8(E)	9	#4	*20'-8"	sp13(E)	2	#4	*19'-8"	sp14(E)	3	#4	*18'-8"	WWW
s1(E)	54	#5	17'-7"	s1(E)	12	#5	17'-7"	s1(E)	18	#5	17'-7"	□
v8(E)	162	#11	20'-8"	v26(E)	36	#11	19'-8"	v27(E)	54	#11	18'-8"	—
v23(E)	108	#6	4'-11"	v23(E)	24	#6	4'-11"	v23(E)	36	#6	4'-11"	—

* Length is height of spiral.

Item	Unit	Total
Structure Excavation	Cu. Yd.	83
Concrete Structures	Cu. Yd.	136
Reinforcement Bars, Epoxy Coated	Pound	4927

- NOTES:**
- Luminaire orientations are for reference only. Numbers show degrees. Zero degrees is true east and numbers increase counterclockwise. In general, luminaires are oriented with the optics perpendicular to the roadway per drawing GE-2, note 8.
 - For additional notes, see Drawing S-2.

McDonough Associates Inc.
Engineers/Architects
130 East Randolph Street, Chicago, Illinois 60601

FILE NAME = 0990348-60F12-001-HML_Foundation.dgn	USER NAME = TKJuegel	DESIGNED - MGB	REVISED -
PLOT SCALE = 1:1,33333	DRAWN - MGB	CHECKED -	REVISED -
PLOT DATE = 3/3/2011	CHECKED -	REVISED -	REVISED -

STATE OF ILLINOIS
DEPARTMENT OF TRANSPORTATION

I-55 AT ARSENAL ROAD
HIGH MAST LIGHT TOWER FOUNDATION AT RETAINING WALL DETAILS
SHEET NO. 1 OF 5 SHEETS

F.A.I. RTE. 55	SECTION 99-2HB-2B-1	COUNTY WILL	TOTAL SHEETS 756	SHEET NO. 437
FED. ROAD DIST. NO. 1 ILLINOIS			FED. AID PROJECT	
CONTRACT NO. 60F12				

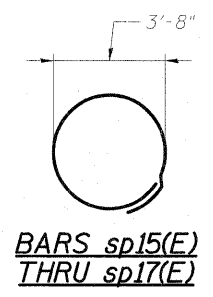
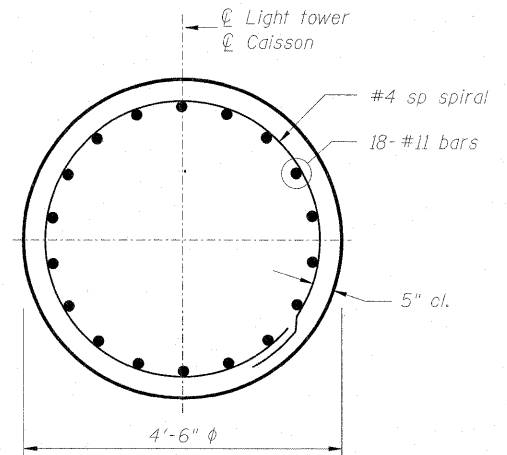
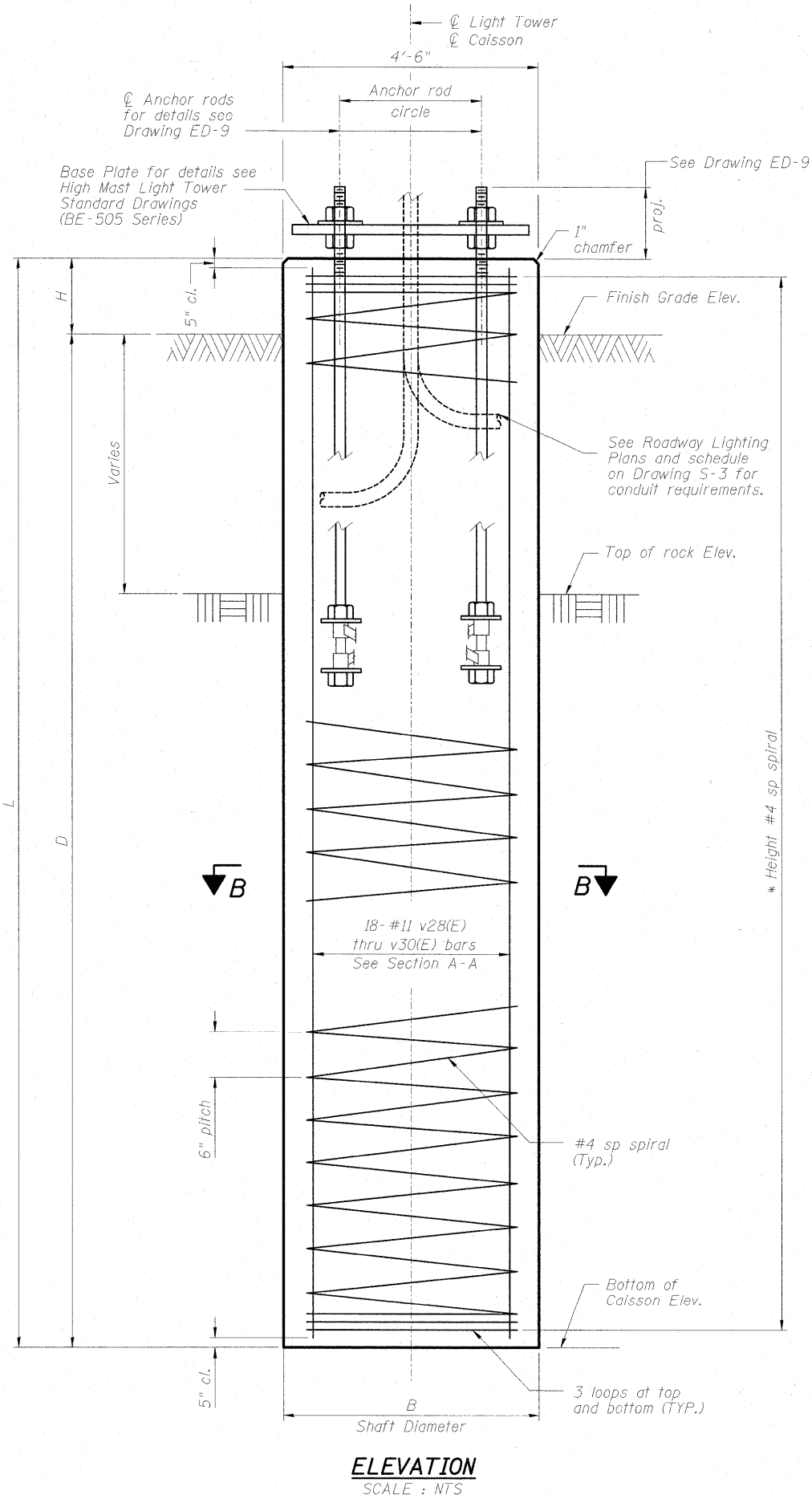

BILL OF MATERIAL

Bar	No.	Size	Length	Shape
sp15(E)	7	#4	*14'-8"	WWM
sp16(E)	23	#4	*15'-8"	WWM
sp17(E)	25	#4	*16'-8"	WWM
v28(E)	126	#11	14'-8"	—
v29(E)	414	#11	15'-8"	—
v30(E)	450	#11	16'-8"	—

* Length is height of spiral

NOTES:

- The anchor rods shall be vertical. No adjustment shall be allowed after the foundation is placed.
- The gap between the foundation and the base plate shall be enclosed with a stainless steel base screen fastened with a stainless steel band.
- The top of the foundation to 18" below grade shall be formed.
- Surface water will not be permitted to enter the hole and all water which may have infiltrated into the hole shall be removed before placing concrete.
- The light tower shall not be erected until after the concrete has been cured according to article 1020.13. of the Standard Specifications.
- Anchor rods shall be straight and shall be according to AASHTO M 314 or ASTM F1554, Grade 725 (Grade 105) and galvanized according to Article 1006.09 of the Standard Specifications.
- Anchor rod information shall be submitted for approval and shall be fully coordinated for approval with tower manufacturer requirements.
- Reinforcement bars shall be according to Article 1006.10. of the Standard Specifications.
- Two anchor rods opposite each other shall have the anchor rod threads peened after nuts are installed.
- For caisson elevations and dimensions see Sheet S-3.
- For anchor Rod cage details see Drawing ED-9.
- For ground rod details see Electrical drawings.
- Splices for spiral reinforcement shall be lap spliced 2'-0" min or welded.
- Elevations, Caisson shaft Lengths and reinforcements are approximate and should be verified and adjusted in field as directed by The Engineer.
- The Shaft Lengths shall be based on soil borings in the plans. If different soils are encountered, the Engineer shall be notified to provide a revised length.
- If field conditions dictate a shorter Caisson Shaft Length than shown in the table, the Contractor shall notify the Engineer regarding the proposed modification and cut the reinforcement bars to the required length. If the Caisson Shaft Length is longer than indicated, the Contractor may raise the bars a maximum of 1'-0" above the bottom of Caisson shaft Elevation. Lap Splices are required for length increase in excess of 2'-0". The Length of the Vertical reinforcement bars shall be the length of the light Tower Foundation (L) minus 10". Cost included in the pay item for "Light Tower Foundation".
- The cost of reinforcement shall be included in the cost of the foundation.
- The Steel Anchor Rod forms shall not be removed for a minimum of 3 days after concrete is poured.
- Anchor rod quantity, diameter and length shall be determined by the tower manufacturer and approved by the Engineer. each foundation shall have a minimum of 8 anchor rods.
- Coordinate the rod circle diameter of the tower with the diameter of the anchor rod cage.

FILE NAME = 0990348-60F12-002-HML Foundation.dgn	USER NAME = TKluegel	DESIGNED - MGB	REVISED -
PLOT SCALE = 1:1.33333	DRAWN - MGB	CHECKED -	REVISED -
PLOT DATE = 3/3/2011	CHECKED -	REVISIONS	REVISED -

STATE OF ILLINOIS
DEPARTMENT OF TRANSPORTATION

I-55 AT ARSENAL ROAD
GROUND MOUNTED HIGH MAST LIGHT TOWER DETAILS

SHEET NO. 2 OF 5 SHEETS

F.A.I. RTE.	SECTION	COUNTY	TOTAL SHEETS	SHEET NO.
55	99-2HB-2B-1	WILL	756	438
CONTRACT NO. 60F12			ILLINOIS FED. AID PROJECT	

Abbreviations:
 EFR - East Frontage Road
 WFC - West Frontage Connector
 WFR - West Frontage Road

NOTES:

1. Luminaire orientations are for reference only. Numbers show degrees. Zero degrees is true east and numbers increase counterclockwise. In general, luminaires are oriented with the optics perpendicular to the roadway per drawing GE-2, note B.

HIGH MAST LIGHT TOWER FOUNDATION TABLE

Sheet No. Lighting Plans	Tower Designation	Location per Lighting Plans			Tower Height (ft.)	H (ft.)	D (ft.)	L (ft.)	R (ft.)	Finish Grade Elevation	Top of Rock Elevation	Bottom of Caisson Elevation	Vertical Bar Designation	Spiral Designation	Rock Excavation cu yd	Service Pad	Serv. Pad Retaining wall	Number of 4" Conduit Stubs				Luminaire Orientations (Note 1)
		Roadway	Station	Offset														North	South	East	West	
RL-1	2 AAB6	WFR	4995+78.00	48.75 RT	120	1.50	15.00	16.50	4.50	519.03	514.90	504.03	v24(E)	sp13(E)	6.40	no	no	2				2, 2
RL-1	2 AST6	EFR	7998+90.00	48.75 LT	120	1.50	15.00	16.50	4.50	519.45	512.50	504.45	v24(E)	sp13(E)	4.74	no	no	2				182, 182
RL-1	2 AST5	EFR	8003+90.00	48.75 LT	120	1.50	15.00	16.50	4.50	522.00	519.50	507.00	v24(E)	sp13(E)	7.36	no	no	2	1			182, 182
RL-2	2 AST2	RAMP A	7013+00.00	67.17 LT	120	1.50	14.00	15.50	4.50	525.97	525.29	511.97	v23(E)	sp12(E)	7.85	full	no	2	1			182, 182
RL-3	3 AAB7	WFR	5018+84.00	85.58 RT	130	1.50	15.00	16.50	4.50	525.65	524.17	510.65	v24(E)	sp13(E)	7.96	full	no	1		2		30, 210, 210
RL-3	2 AAB8	WFR	5023+26.00	55.00 RT	130	1.50	15.00	16.50	4.50	527.56	523.20	512.56	v24(E)	sp13(E)	6.27	full	no		2	1		150, 150
RL-3	2 AAB9	RAMP C	2026+10.00	42.21 RT	130	1.50	15.00	16.50	4.50	533.28	525.78	518.28	v24(E)	sp13(E)	4.42	full	yes		2			200, 200
RL-3	2 ACD4	RAMP C	2024+50.00	48.58 LT	130	1.50	15.00	16.50	4.50	540.00	525.53	525.00	v24(E)	sp13(E)	0.31	full	yes	1		2		205, 205
RL-3	2 ACD5	RAMP C	2020+16.00	44.45 LT	130	1.50	16.00	17.50	4.50	532.69	526.75	516.69	v25(E)	sp14(E)	5.93	full	yes	1	2			182, 182
RL-3	2 AAB1	I-55	1030+02.00	94.00 LT	120	1.50	14.00	15.50	4.50	527.00	525.15	513.00	v23(E)	sp12(E)	7.16	full	no	2	1			2, 2
RL-3	2 ACD1	I-55	1035+03.00	94.00 LT	120	1.50	14.00	15.50	4.50	526.75	526.75	512.75	v23(E)	sp12(E)	8.25	half	no	1	2		1	2, 2
RL-3	2 ACD2	I-55	1040+02.00	94.00 LT	120	1.50	14.00	15.50	4.50	529.80	526.22	515.80	v23(E)	sp12(E)	6.14	full	no	1	2			2, 2
RL-3	2 AST1	I-55	1029+97.00	103.40 RT	120	1.50	16.00	17.50	4.50	544.25	525.35	528.25	v25(E)	sp14(E)	-	full	yes	2	1			182, 182
RL-3	2 AEF1	RAMP B	3031+94.00	72.00 LT	120	1.50	15.00	16.50	4.50	528.75	526.13	513.75	v24(E)	sp13(E)	7.29	full	no	1	2		1	182, 182
RL-3	2 AEF2	RAMP B	3036+80.00	64.00 RT	120	1.50	15.00	16.50	4.50	530.00	525.32	515.00	v24(E)	sp13(E)	6.08	full	no	1	2			182, 182
RL-4	3 AIJ1	RAMP A	7014+87.00	55.06 RT	130	1.50	16.00	17.50	4.50	531.33	527.01	515.33	v25(E)	sp14(E)	6.88	full	yes	2		1		140, 320, 320
RL-4	3 AIJ2	RAMP A	7019+23.00	47.41 RT	130	1.50	15.00	16.50	4.50	541.06	527.68	526.06	v24(E)	sp13(E)	0.95	full	yes		1	2		120, 300, 300
RL-4	2 AIJ3	EFR	8028+33.00	21.25 RT	130	1.50	16.00	17.50	4.50	539.30	527.78	523.30	v25(E)	sp14(E)	2.64	no	no	1	2			150, 150
RL-4	2 AIJ4	EFR	8032+66.00	21.25 RT	130	1.50	16.00	17.50	4.50	538.05	529.80	522.05	v25(E)	sp14(E)	4.56	no	no	1	2			170, 170
RL-4	2 AGH1	RAMP C	2032+98.00	72.66 LT	130	1.50	15.00	16.50	4.50	539.45	527.79	524.45	v24(E)	sp13(E)	1.97	full	yes	1		1	2	260, 260
RL-4	4 AGH3	RAMP B	3025+22.00	82.61 LT	130	1.50	16.00	17.50	4.50	534.36	529.42	518.36	v25(E)	sp14(E)	6.51	full	no			1	2	110, 110, 290, 290
RL-4	2 AGH2	RAMP B	3029+61.00	77.57 RT	130	1.50	16.00	17.50	4.50	526.29	526.29	510.29	v25(E)	sp14(E)	9.42	full	no		2			220, 220
RL-4	2 AGH4	RAMP B	3022+86.00	63.66 RT	130	1.50	16.00	17.50	4.50	530.95	530.95	516.90	v25(E)	sp14(E)	8.28	full	no		2	1		300, 300
RL-4	2 AGH5	RAMP B	3020+11.00	70.60 RT	130	1.50	16.00	17.50	4.50	533.80	531.60	517.80	v25(E)	sp14(E)	8.13	full	no	1	2			350, 350
RL-5	2 ACD6	RAMP C	2016+22.00	50.00 RT	130	1.50	16.00	17.50	4.50	528.33	527.87	512.33	v25(E)	sp14(E)	9.15	full	no	1	2			157, 337
RL-5	2 ACD7	RAMP C	2012+10.00	63.80 RT	130	1.50	16.00	17.50	4.50	529.56	529.04	513.56	v25(E)	sp14(E)	9.12	full	no	1	2			172, 352
RL-5	3 ACD8	RAMP C	2008+97.00	68.88 RT	120	1.50	15.00	16.50	4.50	530.62	529.64	515.62	v24(E)	sp13(E)	8.26	full	no	1	2			2, 2, 182
RL-5	2 ACD3	I-55	1045+02.00	94.00 LT	120	1.50	15.00	16.50	4.50	531.00	529.96	516.00	v24(E)	sp13(E)	8.22	full	no		2			2, 182
RL-5	2 AEF3	RAMP B	3041+81.00	64.00 RT	120	1.50	15.00	16.50	4.50	533.00	529.69	518.00	v24(E)	sp13(E)	6.89	full	no	1	2			182, 182
RL-5	2 AKL1	RAMP E	122+84.00	111.93 RT	130	1.50	16.00	17.50	4.50	533.14	532.17	517.14	v25(E)	sp14(E)	8.85	full	no	1	1		2	220, 220
RL-6	2 AIJ5	EFR	8036+41.00	21.25 RT	130	1.50	16.00	17.50	4.50	539.01	532.39	523.01	v25(E)	sp14(E)	5.53	no	no		2			195, 195
RL-6	4 AGH7	RAMP E	114+62.00	64.93 RT	130	1.50	16.00	17.50	4.50	535.10	531.19	519.10	v25(E)	sp14(E)	7.12	full	no			2		40, 40, 220, 220
RL-6	2 AGH6	RAMP B	3015+53.00	69.57 RT	130	1.50	16.00	17.50	4.50	533.67	531.74	517.67	v25(E)	sp14(E)	8.29	full	no	1	2			30, 30
RL-6	5 AKL2	RAMP E	118+74.00	109.32 RT	130	1.50	16.00	17.50	4.50	532.96	530.74	516.96	v25(E)	sp14(E)	8.12	full	no	2				20, 20, 20, 200, 200
RL-7	4 AKL3	EFR	8050+52.00	73.80 LT	130	1.50	16.00	17.50	4.50	535.00	532.50	519.00	v25(E)	sp14(E)	7.95	full	no	1	2			15, 15, 195, 195
RL-7	2 AKL4	EFR	8055+50.00	76.02 LT	130	1.50	16.00	17.50	4.50	533.85	532.78	517.85	v25(E)	sp14(E)	8.79	full	no		2			35, 35
RL-8	3 ACD9	RAMP C	2003+93.00	29.25 RT	120	1.50	15.00	16.50	4.50	533.50	530.35	518.50	v24(E)	sp13(E)	6.98	no	no	1	2			2, 2, 182
RL-11	3 TEF1	ARSENAL	951+13.00	84.50 RT	130	1.50	16.00	17.50	4.50	552.00	531.81	536.00	v25(E)	sp14(E)	-	half	no			3		182, 272, 272
RL-11	3 TCD1	WFC	6071+22.00	99.42 RT	120	1.50	14.00	15.50	4.50	545.00	540.19	531.00	v23(E)	sp12(E)	5.41	full	no	1	2	1		2, 182, 182
RL-11	2 TCD7	I-55	1109+12.00	95.70 LT	120	1.50	14.00	15.50	4.50	543.50	537.07	529.50	v23(E)	sp12(E)	4.46	full	no	2				2, 2
RL-11	3 TGH1	ARSENAL	953+93.00	69.00 LT	120	1.50	14.00	15.50	4.50	547.75	533.21	533.75	v23(E)	sp12(E)	-	half	no	1	2			2, 2, 182
RL-11	3 TGH2	ARSENAL	958+89.00	89.00 LT	120	1.50	16.00	17.50	4.50	545.50	531.30	529.50	v25(E)	sp14(E)	1.06	full	yes	1	2			2, 2, 182
RL-12	2 TCD2	WFC	6074+12.00	49.28 RT	130	1.50	16.00	17.50	4.50	547.00	541.13	531.00	v25(E)	sp14(E)	5.97	full	no	1	2			220, 220
RL-12	2 TCD3	WFC	6078+17.00	54.06 RT	130	1.50	15.00	16.50	4.50	545.50	539.90	530.50	v24(E)	sp13(E)	5.54	full	no	1	2			220, 220
RL-12	2 TCD4	WFC	6082+17.00	53.00 RT	130	1.50	15.00	16.50	4.50	550.00	539.90	535.00	v24(E)	sp13(E)	2.89	full	yes	1	2			160, 160
RL-12	2 TCD5	WFC	6085+97.00	50.13 RT	130	1.50	16.00	17.50	4.50	560.00	538.40	544.00	v25(E)	sp14(E)	-	full	yes			1	2	95, 95
RL-13	2 TCD6	WFC	6087+70.00	56.60 RT	120	1.50	16.00	17.50	4.50	550.00	538.26	534.00	v25(E)	sp14(E)	2.51	full	yes	1	1		2	2, 2
RL-13	2 TCD8	I-55	1119+05.00	94.00 LT	120	1.50	15.00	16.50	4.50	538.00	537.00	523.00	v24(E)	sp13(E)	8.25	full	no		2			2, 2
RL-13	4 TGH3	WFC	6089+88.00	54.51 RT	120	1.50	16.00	17.50	4.50	559.50	539.33	543.50	v25(E)	sp14(E)	-	full	yes	2	1	1		2, 2, 92, 182
RL-13	3 TGH4	ARSENAL	965+15.00	68.00 RT	130	1.50	16.00	17.50	4.50	560.00	540.36	544.00	v25(E)	sp14(E)	-	full	yes		2			182, 182, 182
RL-13	2 TGH5	I-55	1118+95.00	101.00 RT	120	1.50	15.00	16.50	4.50	539.00	537.00	524.00	v24(E)	sp13(E)	7.66	full	no		2	1		182, 182
RL-13	2 TGH6	ARSENAL	968+00.00	85.29 LT	130	1.50	15.00	16.50	4.50	555.00	543.25	540.00	v24(E)	sp13(E)	1.91	full	yes	1			2	312, 312
RL-14	2 TGH7	ARSENAL	971+78.00	76.08 LT	130	1.50	15.00	16.50	4.50	544.40	537.00	529.40	v24(E)	sp13(E)	4.48	full	yes			1	2	312, 312
RL-14	2 TGH8	ARSENAL	975+59.00	74.18 LT	130	1.50	15.00	16.50	4.50	537.60	537.00	522.60	v24(E)	sp13(E)	8.48	full	no			1	2	290, 290
RL-14	2 TGH9	ARSENAL	979+60.00	70.98 LT	130	1.50	15.00	16.50	4.50	538.50	538.00	523.50	v24(E)	sp13(E)	8.54	full	no				2	277, 277

FILE NAME = 0990348-60F12-003-HML Foundation.dgn	USER NAME = TK1uegel	DESIGNED - MGB	REVISED -
PLOT SCALE = 1:0.0033333		CHECKED -	REVISED -
PLOT DATE = 3/3/2011		DRAWN - MGB	REVISED -
		CHECKED -	REVISED -

**STATE OF ILLINOIS
 DEPARTMENT OF TRANSPORTATION**

**I-55 AT ARSENAL ROAD
 GROUND MOUNTED HIGH MAST LIGHT TOWER DETAILS**

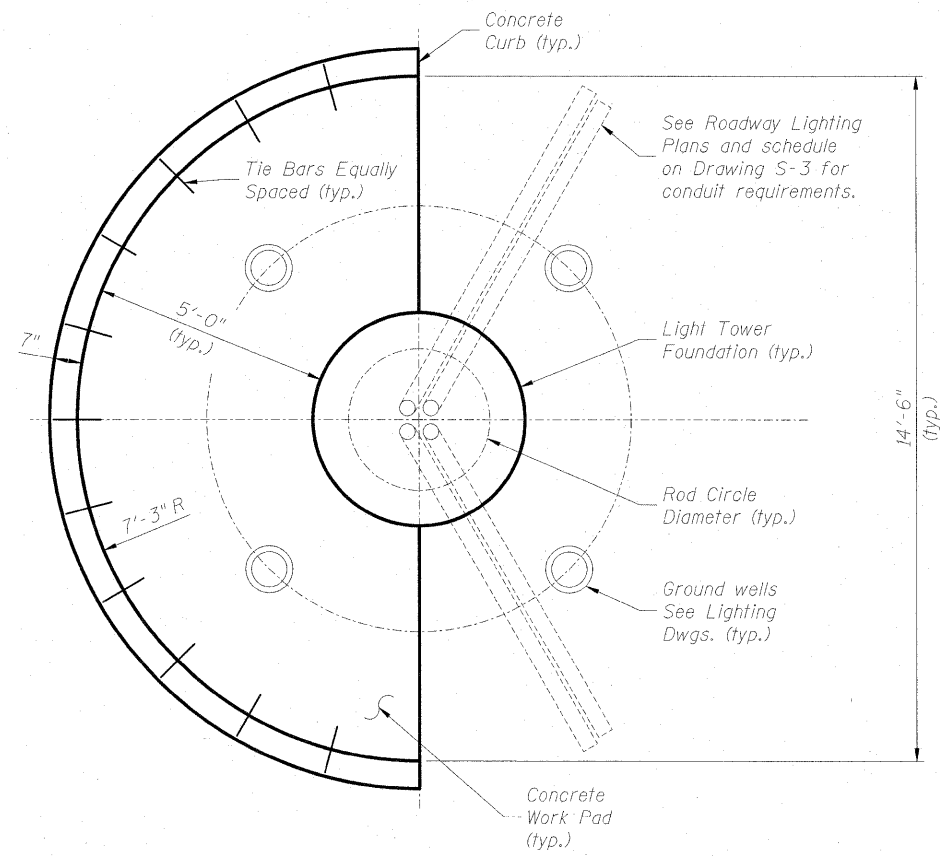

HALF WORK PAD DETAIL

SCALE : NTS

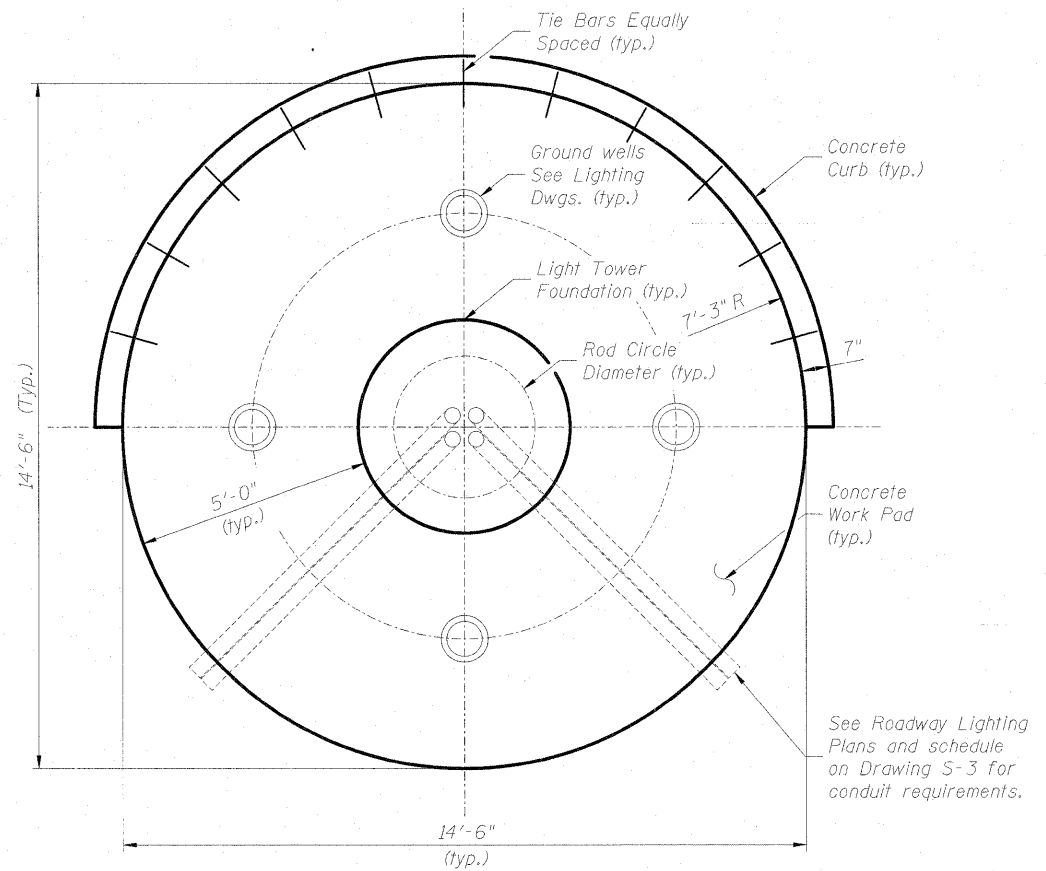

WORK PAD DETAIL

SCALE : NTS

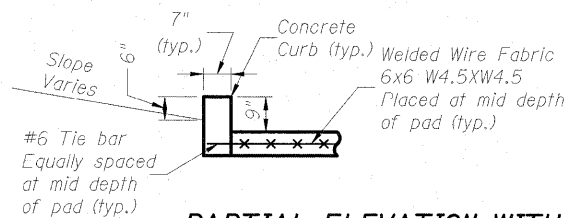

PARTIAL ELEVATION-WITH CURB

SCALE : NTS

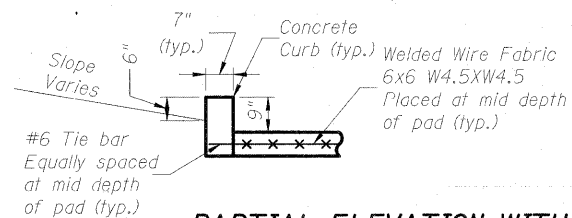

PARTIAL ELEVATION-WITH CURB

SCALE : NTS

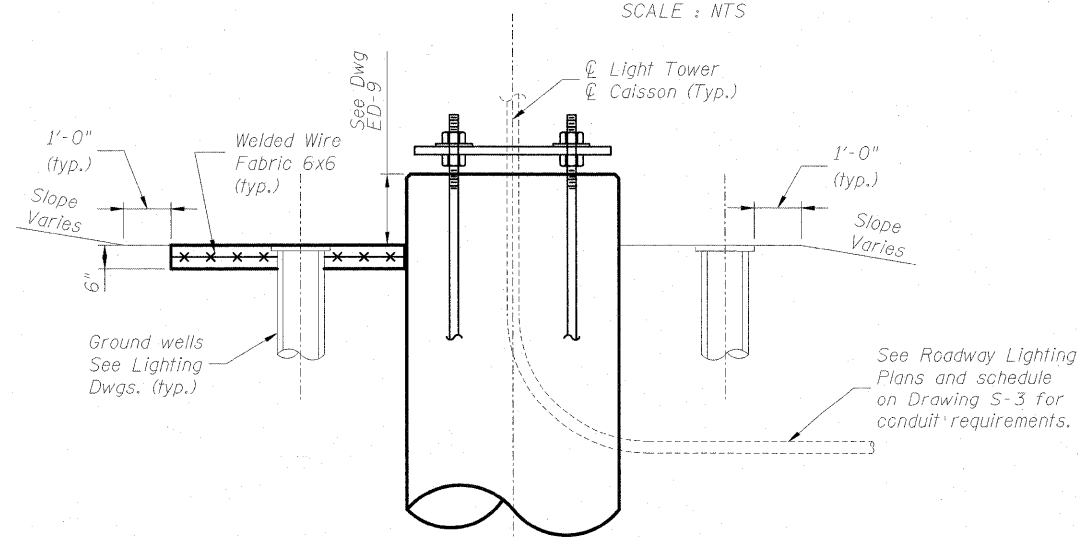

ELEVATION-WITHOUT CURB

SCALE : NTS

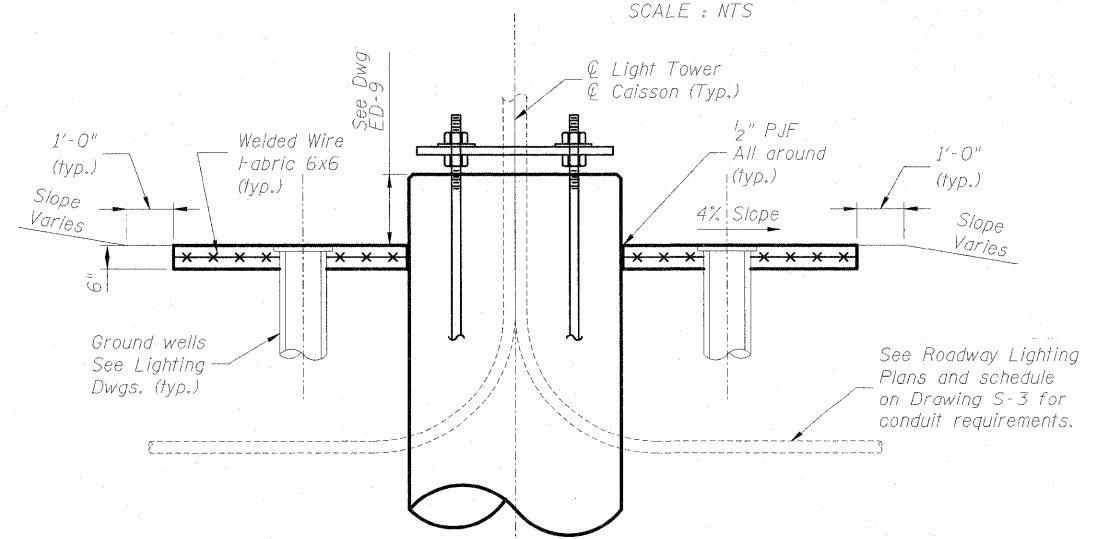

ELEVATION-WITHOUT CURB

SCALE : NTS

NOTE:
 1) Above shown curb details are tentative may not be applicable at various locations.
 2) For providing curb at respective pad locations contractor to submit a prior request to the engineer for approval.

FILE NAME =	USER NAME = TK1uegel	DESIGNED - MGB	REVISED -
0990348-60F12-004-HML Foundation.dgn		CHECKED -	REVISED -
	PLOT SCALE = 1:0.0033333	DRAWN - MGB	REVISED -
	PLOT DATE = 3/3/2011	CHECKED -	REVISED -

F.A.I. RTE.	SECTION	COUNTY	TOTAL SHEETS	SHEET NO.
55	99-2HB-2B-1	WILL	756	440
CONTRACT NO. 60F12				
FED. ROAD DIST. NO. 1 ILLINOIS FED. AID PROJECT				

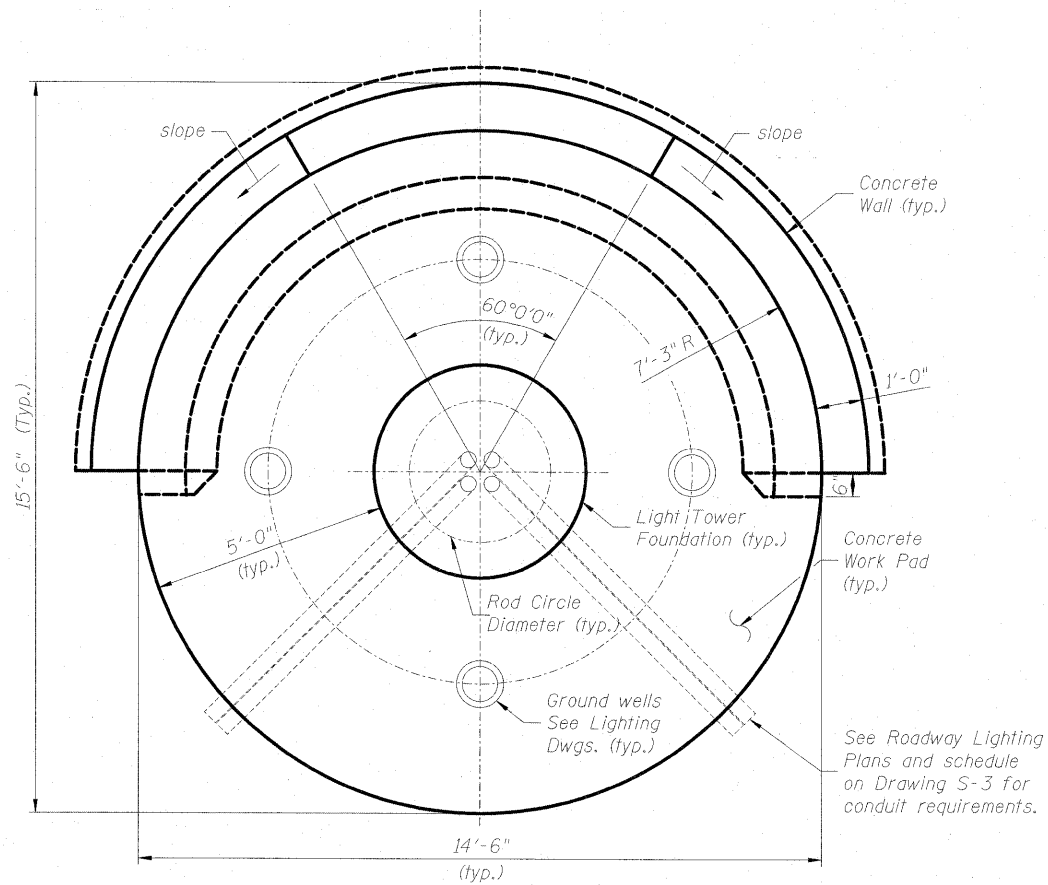

WORK PAD DETAILS WITH WALL

SCALE : NTS

WALL STEM HEIGHT TABLE

Backslope Req'd	L'	'L'
1:2	1	3'-10 1/2"
1:3	8	2'-7"
1:4	3	1'-11 1/4"
1:6	2	1'-3 1/2"

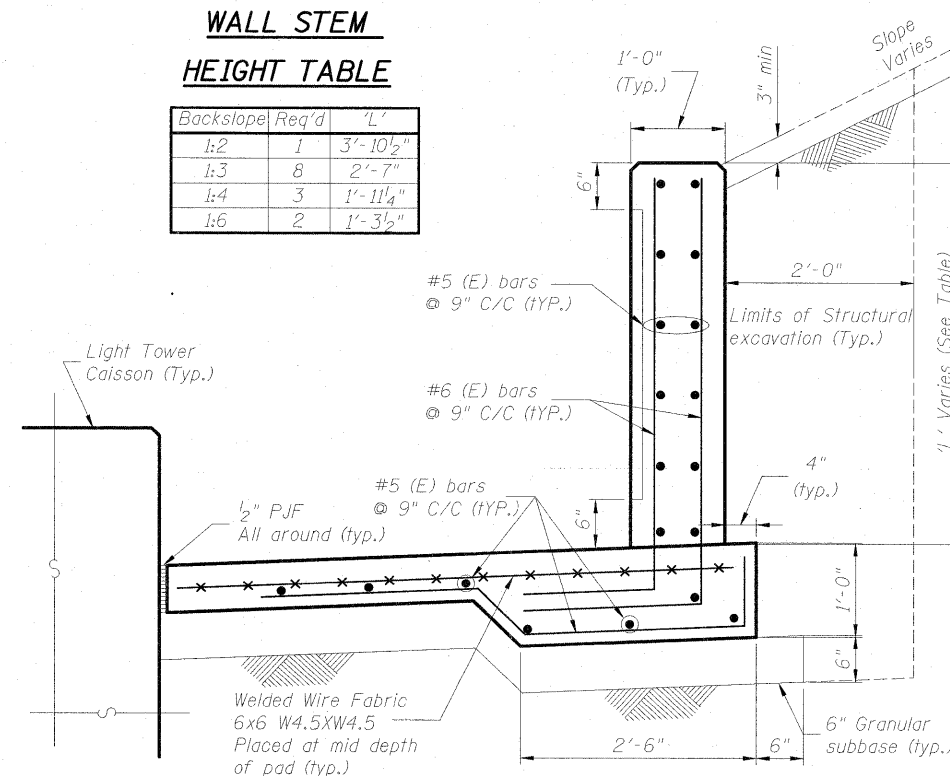

SECTION THRU PAD-WITH WALL

SCALE : NTS

NOTE:

1. The light tower and light tower foundation shall be paid for separately, all remaining work including grading, fill, service pad, rustication, concrete and reinforcement shall be paid for at the contract unit price per each for "Light Tower Service Pad, Special"

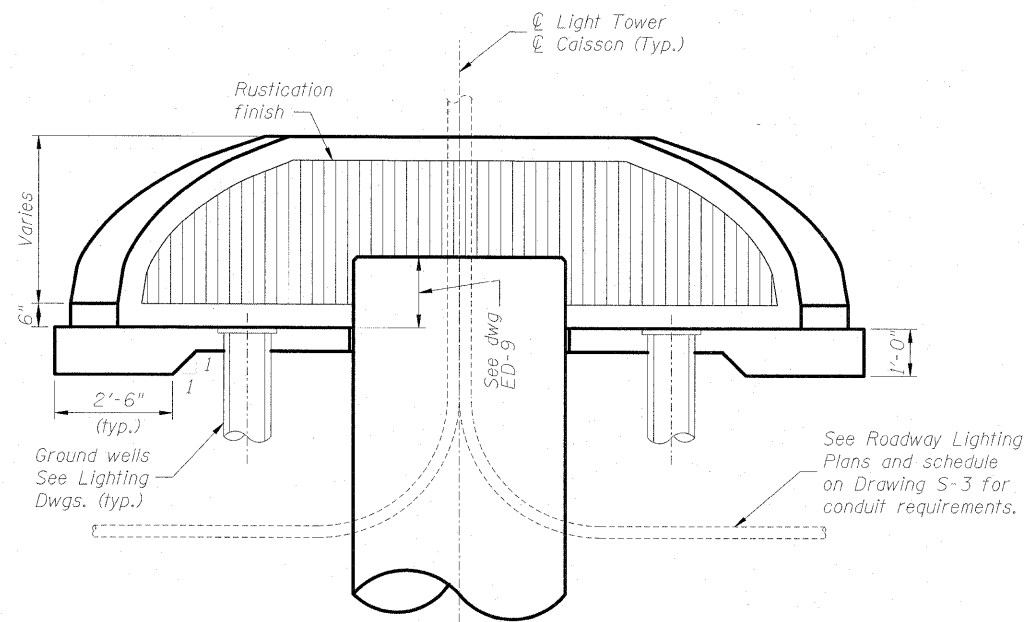

ELEVATION-WITH WALL

SCALE : NTS

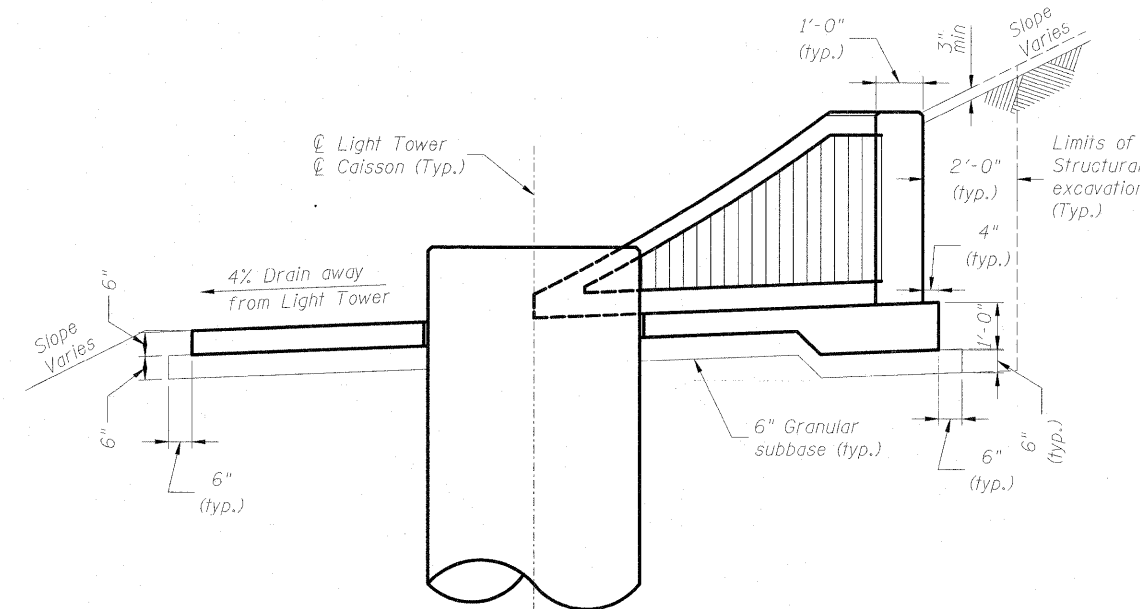

SECTION THRU EMBANKMENT-WITH WALL

SCALE : NTS

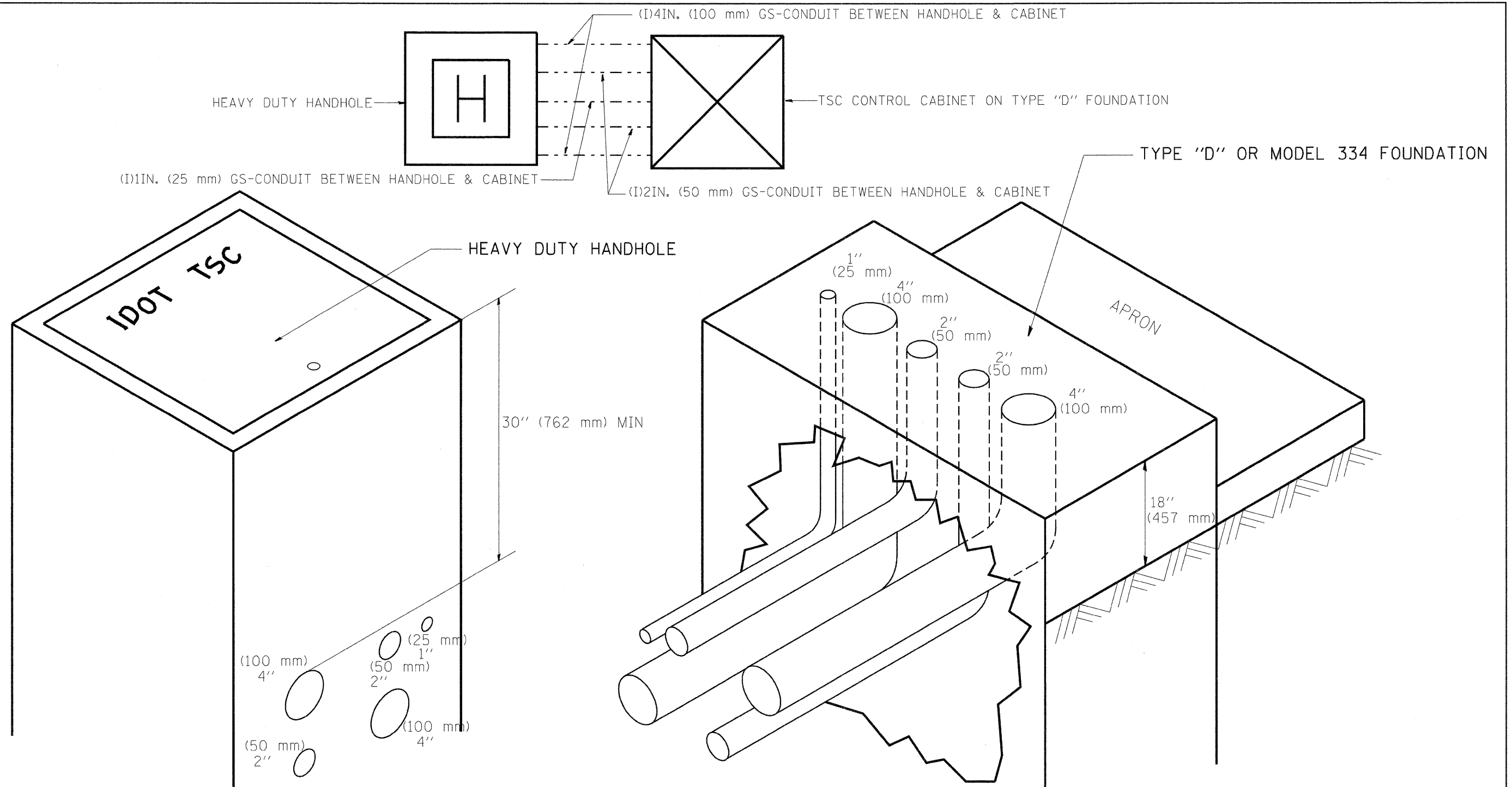

NOTES:

- 1) ALL DUCTS SHALL BE CONED IN HANDHOLES.
- 2) ALL DUCTS SHALL BE GS-CONDUIT & GS 90 DEG. ELBOWS USED WHERE NEEDED.
- 3) ALL DUCTS ENTER HANDHOLE AT MINIMUM DEPTH OF 30 INCH (762 mm)
- 4) ALL HANDHOLE COVERS SHALL READ "IDOT TSC".
- 5) ALL CABINET HANDHOLES SHALL BE HEAVY DUTY.
- 6) DUCTS SHALL BE CENTERED IN CABINET FOUNDATION/HANDHOLE AS SHOWN.
- 7) CONDUITS SHALL BE SPACED 305 mm (1 FOOT) CENTER TO CENTER IN HEAVY DUTY HANDHOLE.
- 8) INSTALL 3/4" X 10' (20 mm X 3 m) COPPER CLAD STEEL GROUND ROD IN HDHH PROVIDED AS CABINET PAD. EXOTHERMIC WELD CONNECTION FROM GROUND ROD TO #6 GROUND WIRE INSULATED (GREEN).
- 9) BOND ALL GSC CONDUITS IN CABINET FOUNDATION.
- 10) INSTALL #6 GROUND WIRE IN 1IN. (25 mm) GSC FROM HANDHOLE TO CABINET.
- 11) TYPE "D" FOUNDATION SHALL BE 18" FROM TOP OF FOUNDATION TO FINISHED GRADE.

FILE NAME = C:\Projects\TSC\TYPICALS\TSCYP08.dgn	USER NAME = mezag	DESIGNED - R.L.	REVISED - 09/96	STATE OF ILLINOIS DEPARTMENT OF TRANSPORTATION TRAFFIC SYSTEMS CENTER	CABINET - HANDHOLE CONDUIT DETAIL			F.A. RTE.	SECTION	COUNTY	TOTAL SHEETS	SHEET NO.
		DRAWN - G.M.	REVISED - 03/99					55	99-2HB-2B-1	WILL	756	442
PLOT SCALE = 100.0000 ' / IN.	CHECKED - R.L.	REVISED - 04/99	REVISED - 07/2010		SCALE: NONE SHEET NO. OF SHEETS STA. TO STA.			FED. ROAD DIST. NO. 1 ILLINOIS FED. AID PROJECT				
PLOT DATE = 7/1/2010	DATE - 06/05/95							CONTRACT NO. 60F12				

TYPE "T" HINGES REQUIRED ONLY ON
ON HEAVY DUTY SPECIAL.

CONDUIT TYP.

CONDUIT TYP.

TYPE "G" HANDLE FOR BOTH HDHH AND HDHH SPECIAL

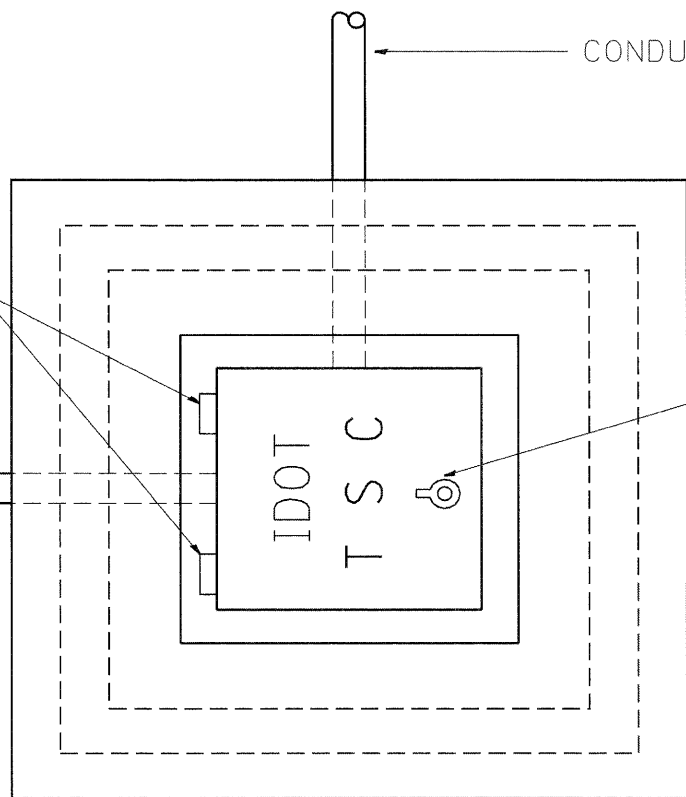

PLAN

HEAVY DUTY HANDHOLE MINIMUM DIMENSIONS (UNHINGED)

A	28" (711 mm)
B	22" (559 mm)
C	8" (200 mm)

(FRAME AND COVER 260 LBS. (118 Kg.) MIN.)

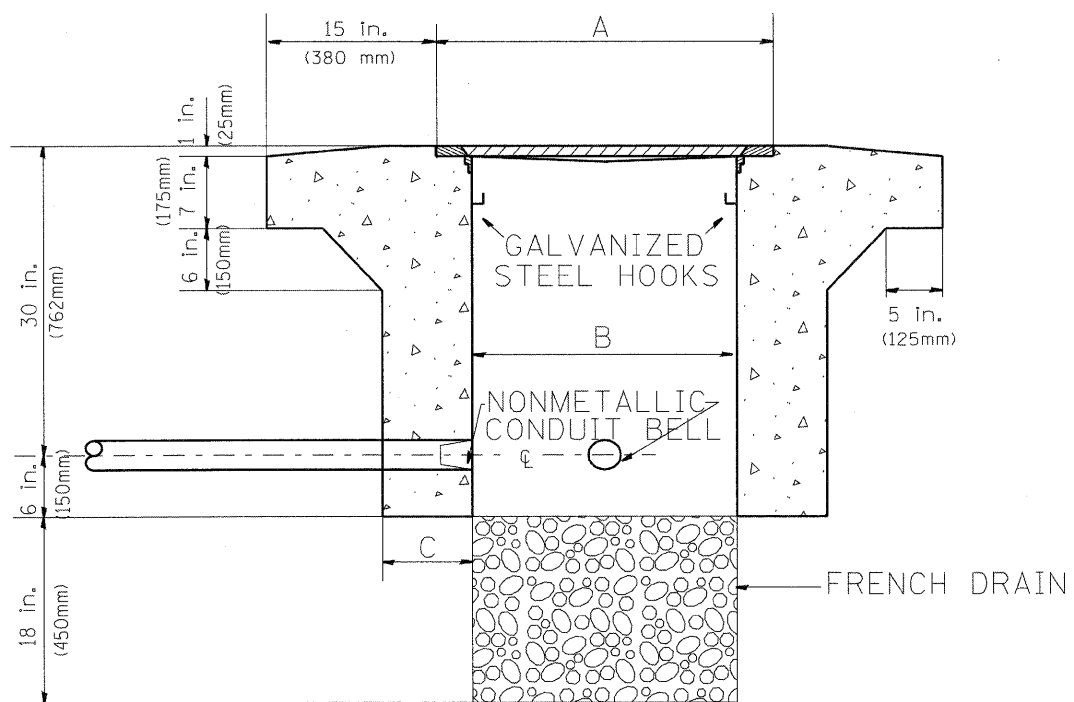

ELEVATION

HEAVY DUTY HANDHOLE SPECIAL MINIMUM DIMENSIONS

A	31.5" (800 mm)
B	30" (762 mm)
C	10" (250 mm)

(FRAME AND COVER 405 LBS. (184 Kg. (405))

PC CONCRETE - HEAVY DUTY HAND HOLE

FILE NAME = C:\Projects\TSC\TYPICALS\TSC\TYP08.dgn	USER NAME = mezag	DESIGNED - R.L.	REVISED - 04/97	STATE OF ILLINOIS DEPARTMENT OF TRANSPORTATION TRAFFIC SYSTEMS CENTER	PC CONCRETE - HEAVY DUTY HAND HOLE			F.A. RTE. 55	SECTION 99-21B-2B-1	COUNTY WILL	TOTAL SHEETS 756	SHEET NO. 443
PLOT SCALE = 100.0000' / IN.	CHECKED - R.L.	DRAWN - G.M.	REVISED -		SCALE: NONE	SHEET NO.	OF SHEETS	STA.	TO STA.	CONTRACT NO. 60F12		
PLOT DATE = 6/30/2010	DATE - 09/11/96	REVISOR -	REVISED -		FED. ROAD DIST. NO. 1 ILLINOIS FED. AID PROJECT							
TRAFFIC SYSTEMS CENTER (TY-1TSC-400#15)												

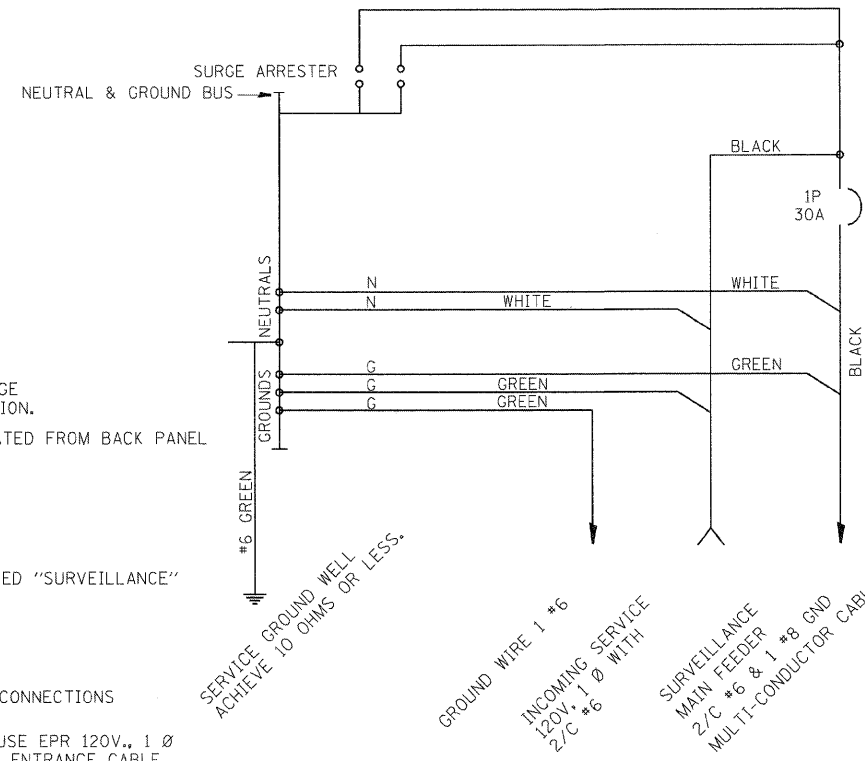
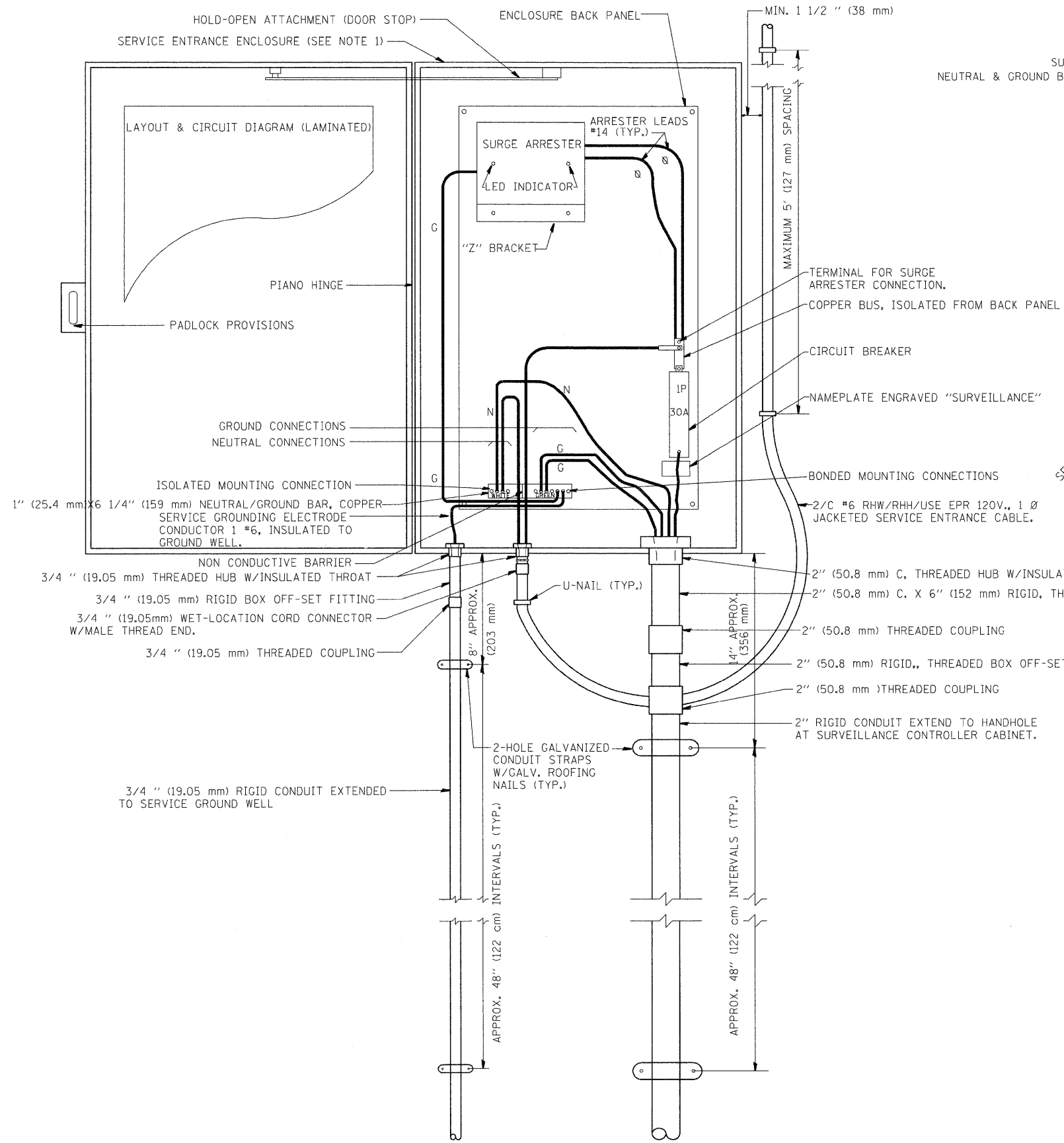

SCHEMATIC DIAGRAM

- NOTES:**
- 1.- ELECTRIC SERVICE SHALL BE OF THE VOLTAGE INDICATED. WHERE 120-VOLT SERVICE IS INDICATED, SERVICE DROP CABLE SHALL BE INSTALLED ACCORDINGLY AND LIGHTING MAIN FEEDER CABLE SHALL BE OMITTED.
 - 2.- THE ELECTRIC SERVICE BOX SHALL BE NEMA 4X STAINLESS STEEL, NOMINALLY 12" (305 mm) X 18" (457 mm) X 8" (203 mm), WITH PIANO HINGED DOOR, STEEL BACK PANEL, FAST-ACTING STAINLESS STEEL ENCLOSURE CLAMPS, PADLOCK PROVISIONS, DOOR STOP KIT AND STEEL BACK PANEL, HOFFMAN CATALOG A-16H1208SS6LP/A-16P2/A-DSTOPK/C-PMK12, OR APPROVED EQUAL.
 - 3.- THE ELECTRIC SERVICE EQUIPMENT ASSEMBLY SHALL BE UL LABELED, SUITABLE FOR USE AS SERVICE EQUIPMENT.
 - 4.- CIRCUIT BREAKERS SHALL BE THERMAL MAGNETIC BOLT-ON TYPE WITH A MINIMUM INTERRUPTING CAPACITY OF 25,000 SYMMETRICAL AMPERES AT 240 VOLTS. THEY SHALL BE LOCKABLE IN THE "OFF" POSITION FOR COMPLIANCE WITH OSHA LOCK-OUT/TAG-OUT REQUIREMENTS. HANDLES SHALL BE TRIP FREE.
 - 5.- THE SURGE PROTECTOR SHALL BE SUITABLE FOR 240/120 VOLT SINGLE PHASE 60HZ AC ELECTRICAL SERVICE, WITH A SURGE ENERGY CAPABILITY OF >3600 JOULES OR BETTER AT 8/20 MICROSECONDS, RATED -40 TO 65 DEGREES C., WITH LED OPERATING INDICATORS, AND SHALL BE UL LISTED PER UL 1449, CUTLER-HAMMER CMOV 230L065XST OR APPROVED EQUAL. SURGE PROTECTOR SHALL BE WIRED FOR 120 V SERVICE. FOLLOW MANUFACTURER RECOMMENDED WIRING SPECIFICATIONS.
 - 6.- BUS BARS, CONNECTORS AND LUGS SHALL BE COPPER, INSULATED AND ISOLATED AND CONFIGURED TO PREVENT SHORTED CONDITIONS FROM TIGHTENING TERMINATIONS, ETC. THE OVERALL BUS SECTION SHALL BE CONFIGURED BEHIND AN INSULATING BARRIER SHIELD WHICH IS REMOVABLE FOR ACCESS TO CONNECTIONS.
 - 7.- THE COMBINATION GROUND AND NEUTRAL BAR SHALL BE CONFIGURED WITH SEPARATE GROUND AND NEUTRAL SECTIONS AND SPARE TERMINALS AS INDICATED. THE HEADS OF GROUND SCREWS SHALL BE PAINTED GREEN. THE HEADS OF NEUTRAL SCREWS SHALL BE PAINTED WHITE.
 - 8.- A PLASTIC LAMINATED LAYOUT AND CIRCUIT DIAGRAM SHALL BE AFFIXED TO THE INTERIOR SIDE OF THE ENCLOSURE DOOR.
 - 9.- A 2-COLOR ENGRAVED PLASTIC NAMEPLATE, ATTACHED WITH SCREWS, AND ENGRAVED AS INDICATED, SHALL BE PROVIDED FOR EACH MAIN BREAKER.
 - 10.- PROVIDE ON LAYOUT AND CIRCUIT DIAGRAM A BILL OF MATERIALS USED WITH CATALOG NUMBERS.
 - 11.- REFER TO T.S.C. TYPICAL DRAWING TY-1TSC-400*20 FOR POLE MOUNTED DISCONNECT MOUNTING DETAILS.

ELECTRIC SERVICE
GENERAL LAYOUT DIAGRAM

FILE NAME = C:\Projects\TSC\TYPICAL\TSC\TYP08.dgn	USER NAME = mezag	DESIGNED - R.L.	REVISED - 03/01/99	STATE OF ILLINOIS DEPARTMENT OF TRANSPORTATION TRAFFIC SYSTEMS CENTER	DISTRICT 1 SURVEILLANCE POLE-MOUNTED ELECTRIC SERVICE BOX DETAIL			F.A. RTE. 55	SECTION 99-2HB-2B-1	COUNTY WILL	TOTAL SHEETS 756	SHEET NO. 444
PLOT SCALE = 1/8" = 1' / IN.	CHECKED - R.L.	REVISOR - G.M.	REVISOR - 03/30/99		SCALE: NONE	SHEET NO. OF	SHEETS	STA.	TO STA.	CONTRACT NO. 60F12		
PLOT DATE = 6/30/2010	DATE - 02/24/99	REVISOR - R.L.	REVISOR - 04/99							ILLINOIS FED. AID PROJECT		
	DATE - 04/12/99	REVISOR - R.L.	REVISOR - 04/12/99							TRAFFIC SYSTEMS CENTER (TY-1TSC-400#19)		

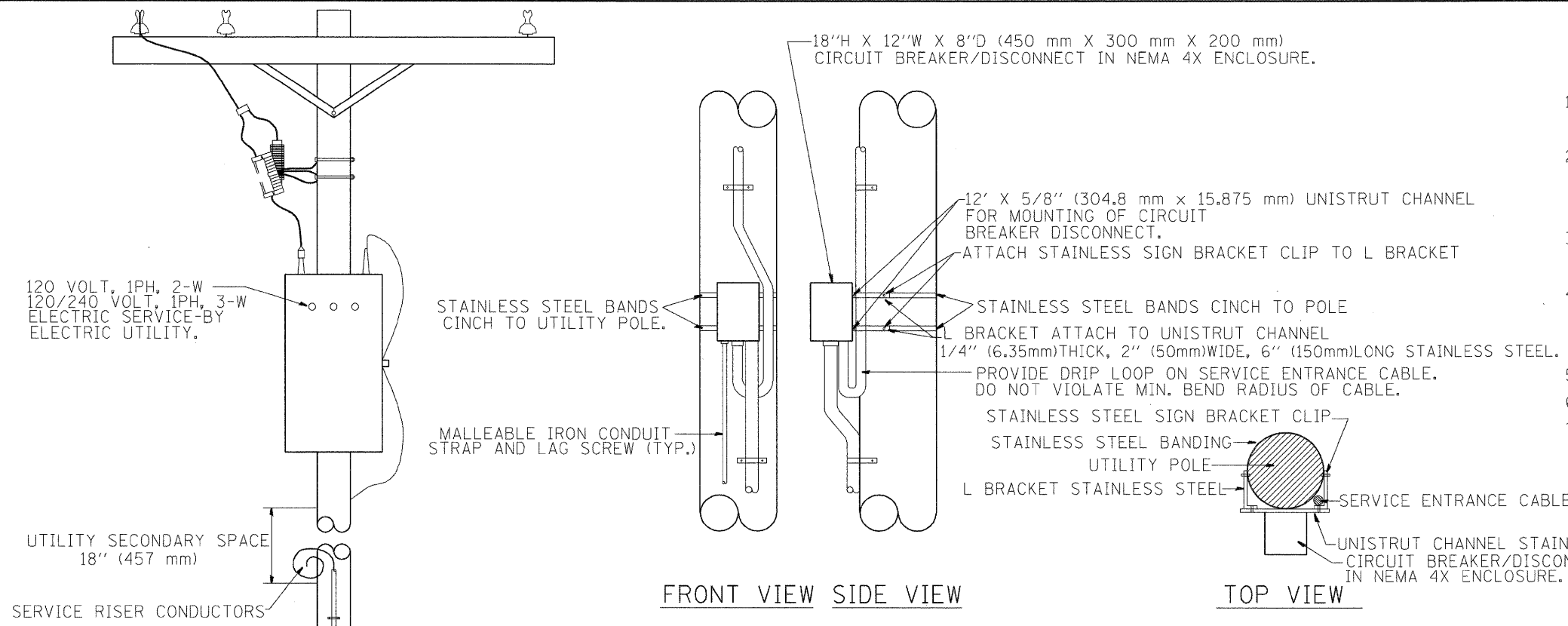

- NOTES:**
- 1.- ALL CONDUIT BUSHINGS SHALL HAVE AN ISOLATED THROAT.
 - 2.- PROVIDE HEAT SHRINK BOOT AT THE TOP OF THE SERVICE ENTRANCE CABLE FOR MOISTURE PROOFING.
 - 3.- ALL CONNECTIONS TO GROUND RODS SHALL BE EXOTHERMIC UNLESS OTHERWISE NOTED.
 - 4.- ATTACH INCOMING ELECTRIC SERVICE CABLE TO UTILITY POLE EVERY 5 FEET USING INSULATED U-NAIL.
 - 5.- PROVIDE CABLE RACK IN HANDHOLES.
 - 6.- ALL CONDUCTORS SHALL BE COPPER.
 - 7.- PROVIDE STAINLESS STEEL HARDWARE TO ATTACH L BRACKETS TO UNISTRUT AND TO SIGN HANGER.

FRONT VIEW SIDE VIEW TOP VIEW

**NTS
DISCONNECT MOUNTING DETAIL**

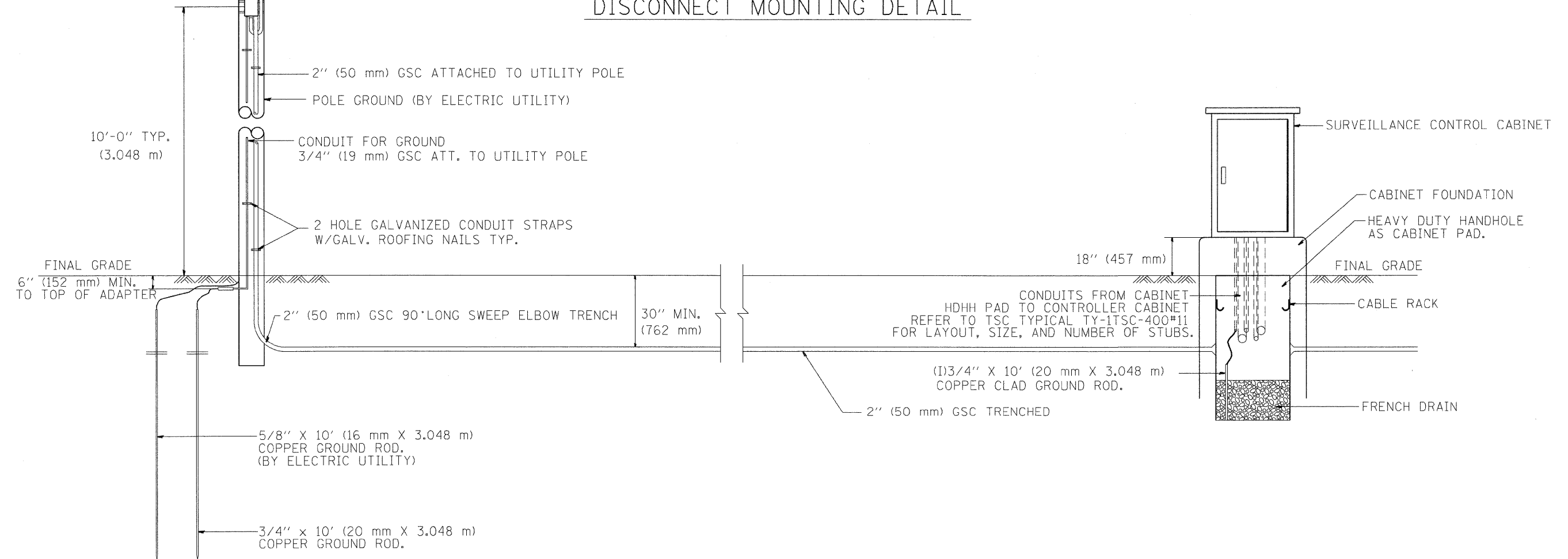

FILE NAME =	USER NAME = mezeg	DESIGNED - R.L.	REVISED -	STATE OF ILLINOIS DEPARTMENT OF TRANSPORTATION TRAFFIC SYSTEMS CENTER	POLE MOUNTED DISCONNECT MOUNTING DETAILS			F.A. RTE.	SECTION	COUNTY	TOTAL SHEETS	SHEET NO.		
C:\Projects\TSC\TYPICALS\TSC\TYP08.dgn		DRAWN - G.M.	REVISED -		SCALE: NONE	SHEET NO.	OF SHEETS	STA.	TO STA.	55	99-2HB-2B-1	WILL	756	445
		CHECKED - R.L.	REVISED -											
		DATE - 03/30/99	REVISED -											
CONTRACT NO. 60F12												FED. ROAD DIST. NO. 1 ILLINOIS FED. AID PROJECT		

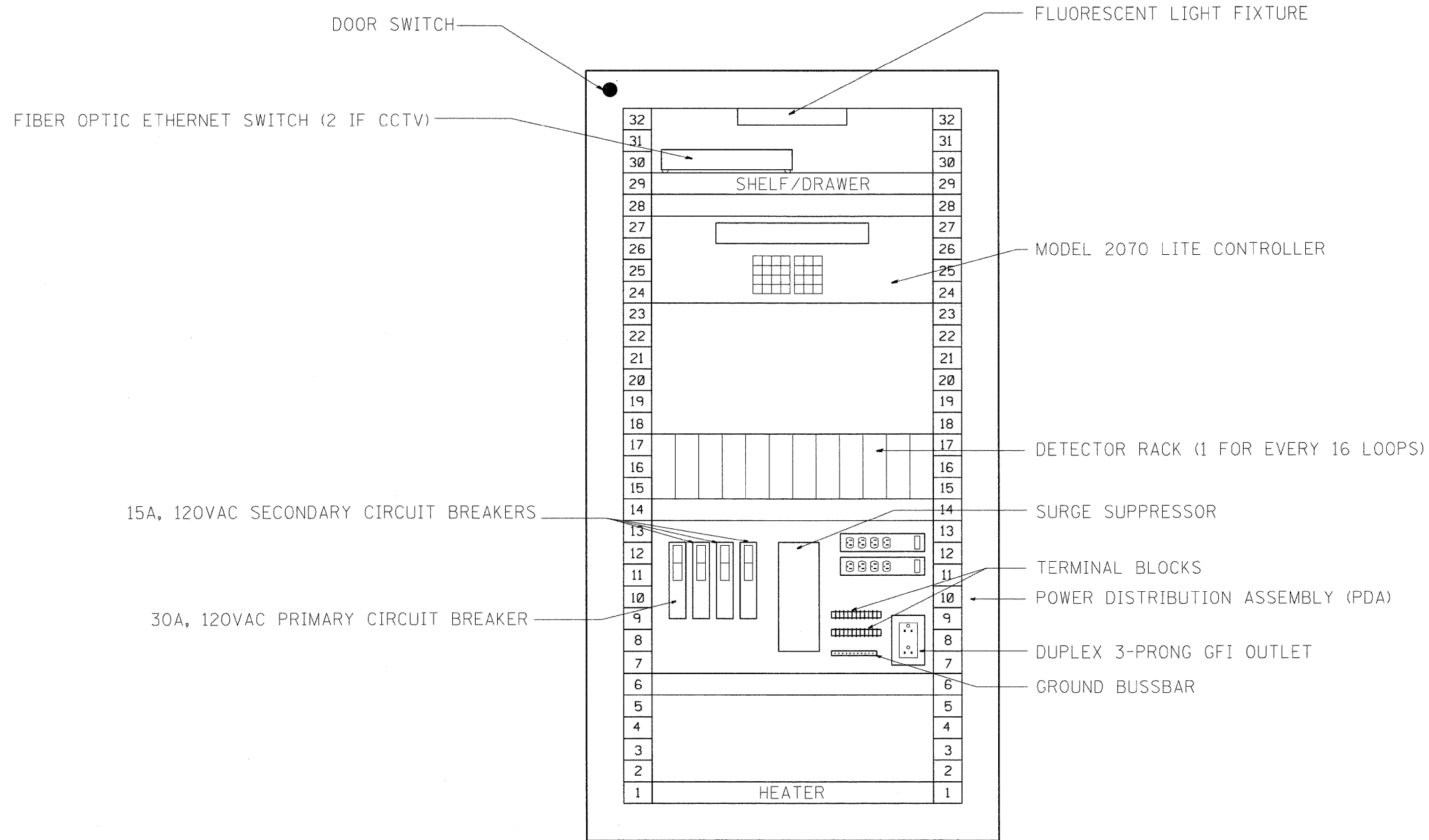

SYSTEM DETECTORS
FRONT VIEW (TYPICAL)

FILE NAME = C:\d106010\165TCTYP.DGN	USER NAME = mezag	DESIGNED - J.S.	REVISED - 01/27/2010	STATE OF ILLINOIS DEPARTMENT OF TRANSPORTATION TRAFFIC SYSTEMS CENTER	CABINET, MODEL 334 RACK LAYOUT			F.A. RTE.	SECTION	COUNTY	TOTAL SHEETS	SHEET NO.		
C:\02092010 Submittal\160NAPERVTYP.dgn		DRAWN - G.M.	REVISED - 03/04/2010		SCALE: NONE	SHEET NO.	OF SHEETS	STA.	TO STA.	55	99-2HB-2B-1	WILL	756	446
		CHECKED - R.L.	REVISED -		CONTRACT NO. 60F12									
		DATE - 12/28/09	REVISED -		FED. ROAD DIST. NO. 1 ILLINOIS FED. AID PROJECT									

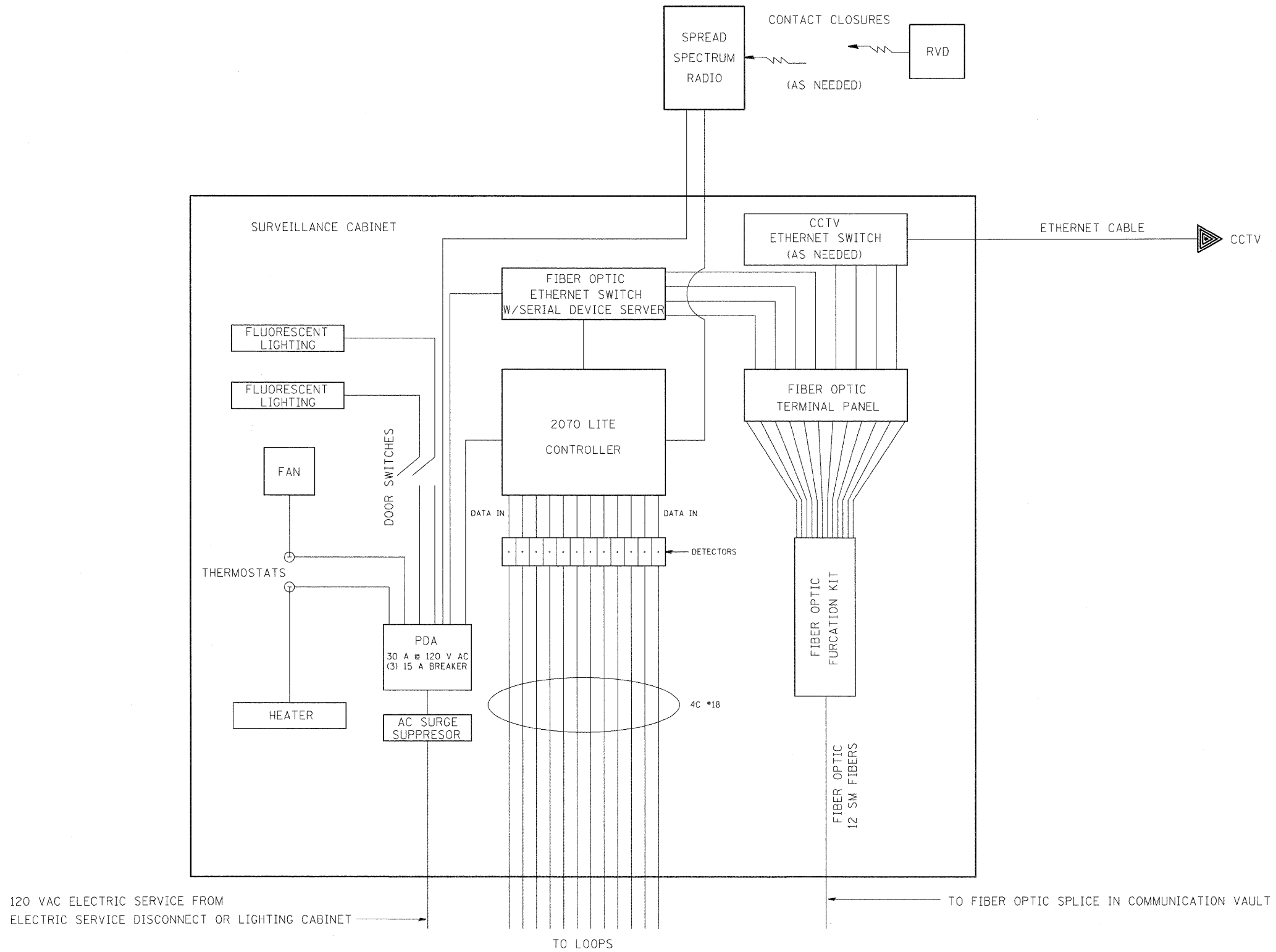

12 LOOP COUNT, OCCS, SPEED, CLASSIFICATION
DETECTOR SYSTEM SINGLE LINE DIAGRAM

FILE NAME = C:\d106010\155TCTYP.DGN	USER NAME = mezag	DESIGNED - J.G.	REVISED - 01/25/2010	STATE OF ILLINOIS DEPARTMENT OF TRANSPORTATION TRAFFIC SYSTEMS CENTER	CABINET MODEL 334 WIRING DETAILS			F.A. RTE.	SECTION	COUNTY	TOTAL SHEETS	SHEET NO.			
C:\02092010_Submitto\180NAPERVTYP.dgn		DRAWN - G.M.	REVISED -		SCALE: NONE	SHEET NO.	OF	SHEETS	STA.	TO STA.	55	99-2HB-2B-1	WILL	756	447
PLDT SCALE = 100.0000 / 1 IN.		CHECKED - J.G.	REVISED -												
PLDT DATE = 6/30/2010		DATE - 12/29/09	REVISED -												
CONTRACT NO. 60F12											FED. ROAD DIST. NO. 1 ILLINOIS FED. AID PROJECT				

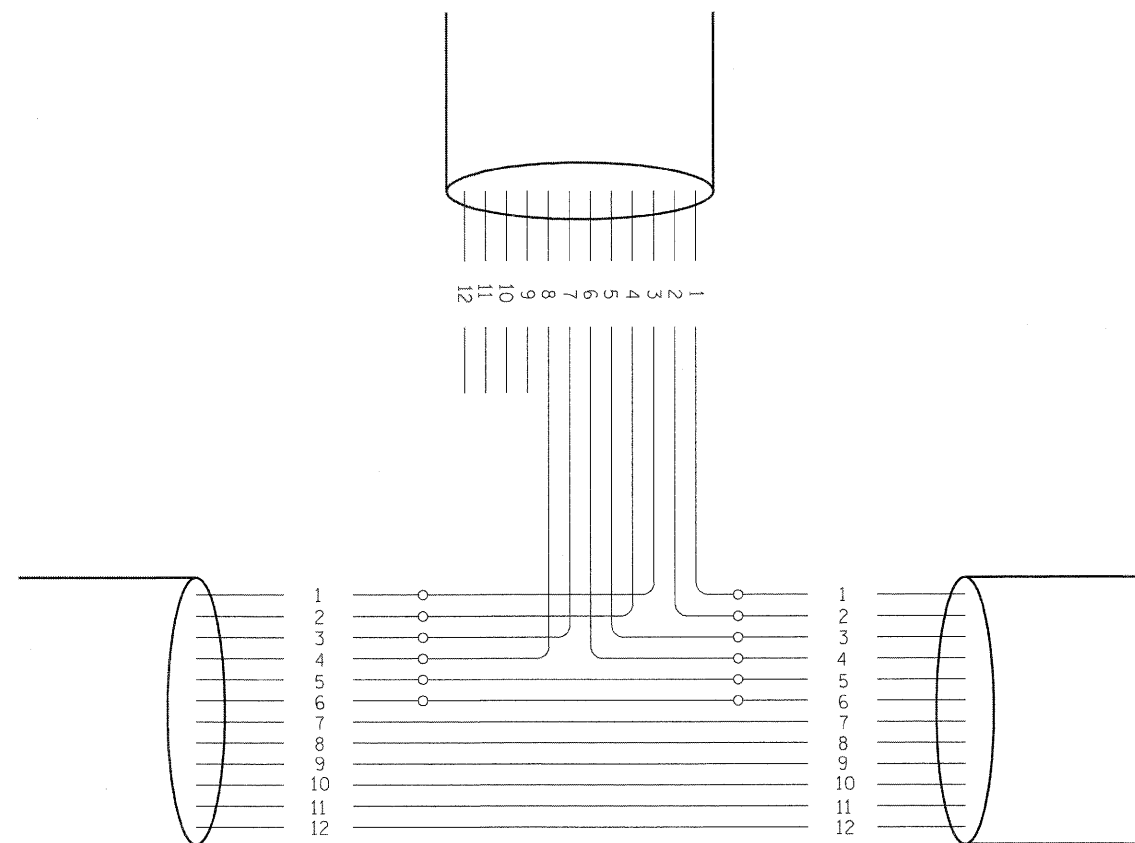
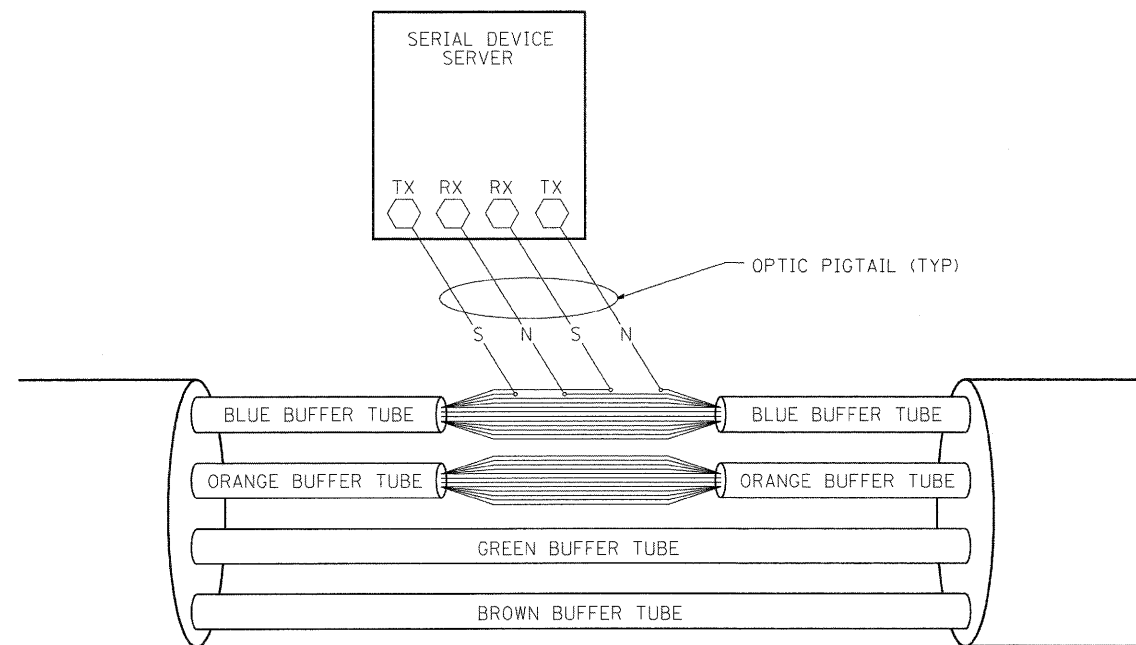

PHYSICAL SPLICE DETAILS (TYP)
(NOT TO SCALE)

FIBERS		FUNCTION	APPLICATION DESCRIPTION
FIBER NO.	COLOR CODE		
1	BLUE	IN TX	DATA CIRCUIT
2	ORANGE	IN RX	
3	GREEN	OUT RX	
4	BROWN	OUT TX	
5	SLATE	IN TX	DMS
6	WHITE	IN RX	
7	RED	OUT RX	
8	BLACK	OUT TX	
9	YELLOW	IN TX	CCTV
10	VIOLET	IN TX	
11	ROSE	OUT RX	
12	AQUA	OUT TX	

NOTE:

1.- THIS DIAGRAM IS PROVIDED FOR ILLUSTRATION PURPOSES ONLY AND DEPICTS A TYPICAL FIBER OPTIC SPLICE.

FILE NAME = C:\d106010\155TSC TYP.DGN	USER NAME = mezag	DESIGNED - J.G.	REVISED - 03/04/2010	STATE OF ILLINOIS DEPARTMENT OF TRANSPORTATION TRAFFIC SYSTEMS CENTER	FIBER OPTIC SPLICING TYPICAL			F.A. RTE. 55	SECTION 99-2HB-2B-1	COUNTY WILL	TOTAL SHEETS 756	SHEET NO. 448
C:\02092010 Submittal\182NAPERVTYP.dgn		DRAWN - G.M.	REVISED -		SCALE: NONE	SHEET NO.	OF SHEETS	STA.	TO STA.	CONTRACT NO. 60F12		
		CHECKED - J.G.	REVISED -							FED. ROAD DIST. NO. 1 ILLINOIS FED. AID PROJECT		
		DATE - 12/29/09	REVISED -									

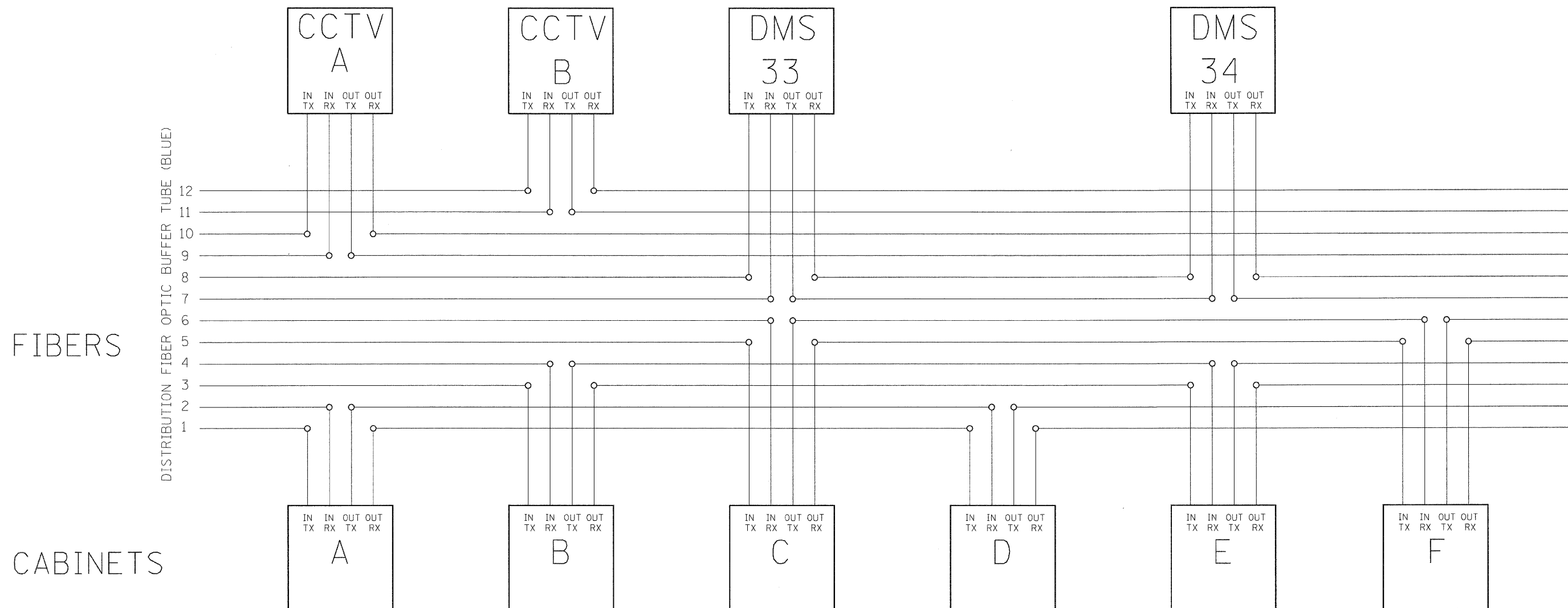

FIBERS 1 AND 2 CABINETS 1, 4, 7, 10, 13, 16, 19, 22, 25, 28, 31, 34, 37, 40, 43, 46, 49.
 FIBERS 3 AND 4 CABINETS 2, 5, 8, 11, 14, 17, 20, 23, 26, 29, 32, 35, 38, 41, 44, 47, 50.
 FIBERS 5 AND 6 CABINETS 3, 6, 9, 12, 15, 18, 21, 24, 27, 30, 33, 36, 39, 42, 45, 48.
 FIBERS 7 AND 8 DMS 33, DMS 34.
 FIBERS 9 AND 10 CCTV 50, 49, 47B, 47, 45, 43A, 42, 40, 38, 37, 35A, 34, 32, 30A, 29.
 FIBERS 11 AND 12 CCTV 51, 49A, 48, 47A, 46, 44, 43, 40A, 39, 37A, 36, 35, 32A, 31, 30.

NOTE:

- 1.- CABINETS 8A, 8B, 8C, 32, 33, 39, 46, 47 ARE SPSSRVDS, SO THEY DO NOT GET ATTACHED TO THE FIBER.
- 2.- CCTV 49 AND 49A ARE IN THE ARSENAL RD. CONTRACT.

FILE NAME = C:\02092010\SUBMITTAL\180NAPERVTP.dgn	USER NAME = mezoq	DESIGNED - J.G.	REVISED - 01/27/2010	STATE OF ILLINOIS DEPARTMENT OF TRANSPORTATION TRAFFIC SYSTEMS CENTER	FIBER OPTIC SPLICING DETAIL			F.A.I. RTE. 55	SECTION 99-2HB-2B-1	COUNTY WILL	TOTAL SHEETS 756	SHEET NO. 449
		DRAWN - G.M.	REVISED - 03/05/2010		SCALE: NONE	SHEET NO.	OF SHEETS	STA.	TO STA.	CONTRACT 60F12		
		CHECKED - J.G.	REVISED - 04/08/2010		FED. ROAD DIST. NO. 1 ILLINOIS FED. AID PROJECT							
		DATE - 12/29/09	REVISED -		TRAFFIC SYSTEMS CENTER 4TY-1TSC-400#42)							

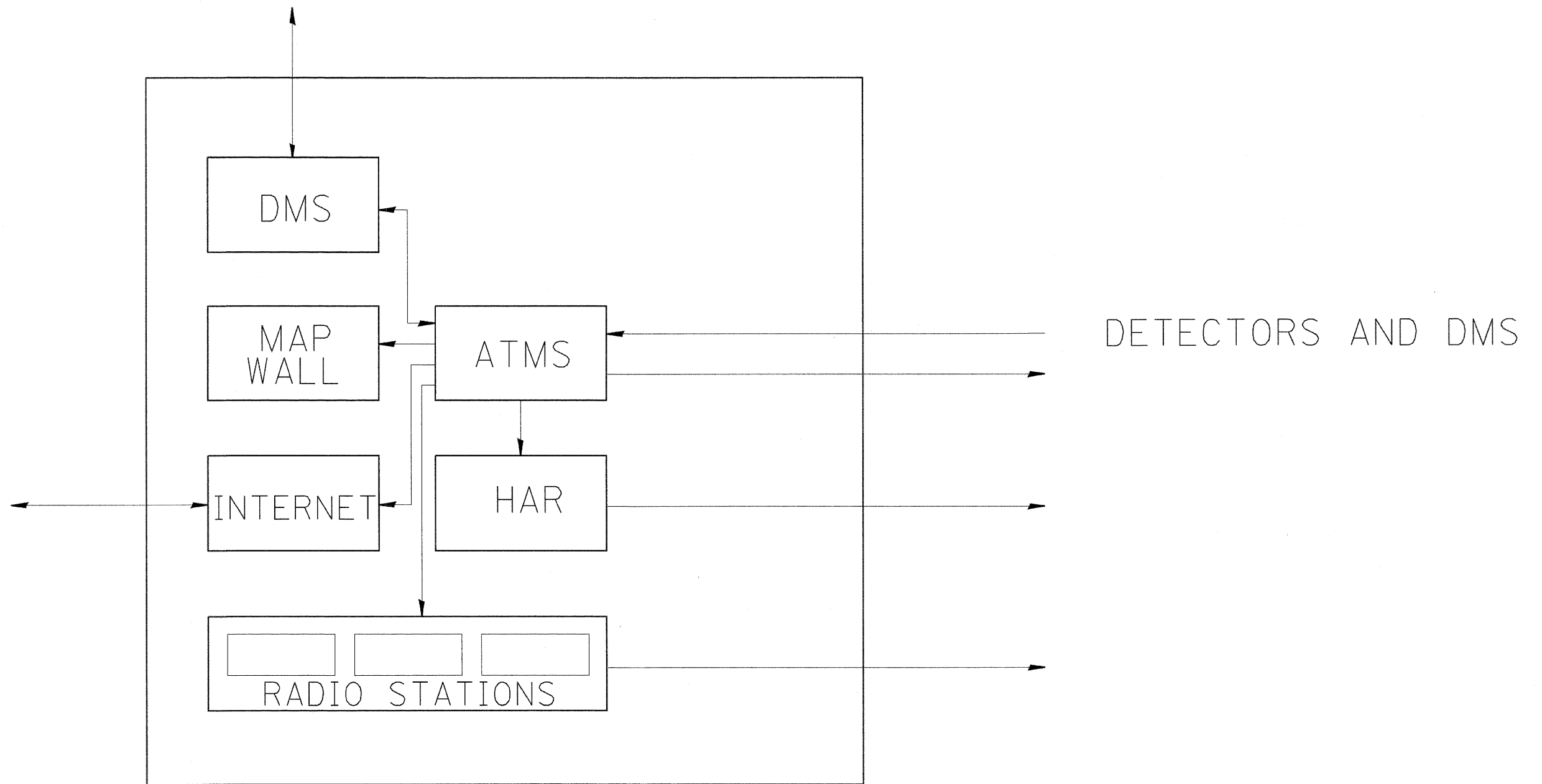

TSC

FILE NAME = C:\d106010\155TCTYP.DGN	USER NAME = mezeg	DESIGNED - J.G.	REVISED -
C:\02092010 Submittal\100NAPERVTYP.dgn		DRAWN - G.M.	REVISED -
		CHECKED - J.G.	REVISED -
		DATE - 01/07/2010	REVISED -

STATE OF ILLINOIS
DEPARTMENT OF TRANSPORTATION
 TRAFFIC SYSTEMS CENTER

TSC ATMS			
SCALE: NONE	SHEET NO.	OF SHEETS	STA. TO STA.

F.A. RTE.	SECTION	COUNTY	TOTAL SHEETS	SHEET NO.
55	99-2HB-2B-1	WILL	756	450
CONTRACT NO. 60F12				
FED. ROAD DIST. NO. 1 ILLINOIS FED. AID PROJECT				

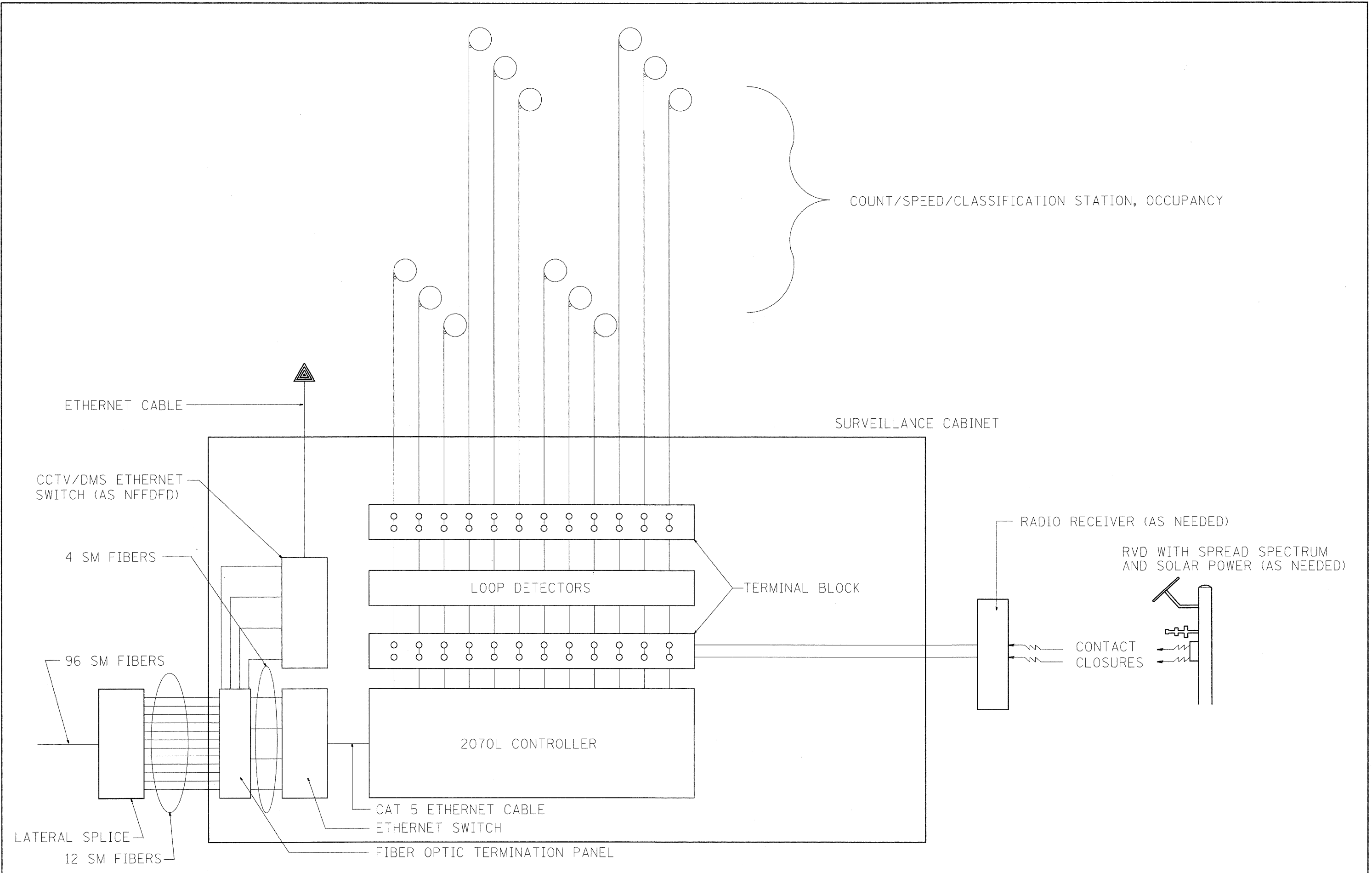

FILE NAME = C:\d106010\155TCTYP.DGN	USER NAME = mezeg	DESIGNED - J.G.	REVISED - 01/27/2010	STATE OF ILLINOIS DEPARTMENT OF TRANSPORTATION TRAFFIC SYSTEMS CENTER	LOOP DETECTOR/SPEED DETECTOR CABINET LAYOUT			F.A. RTE.	SECTION	COUNTY	TOTAL SHEETS	SHEET NO.				
C:\02092010_Submittal\180NAPERVITYP.dgn		DRAWN - G.M.	REVISED - 03/05/2010		SCALE: NONE	SHEET NO.	OF SHEETS	STA.	TO STA.	FED. ROAD DIST. NO. 1	ILLINOIS FED. AID PROJECT	55	99-2HB-2B-1	WILL	756	451
		CHECKED - J.G.	REVISED -													
		DATE - 12/29/09	REVISED -													

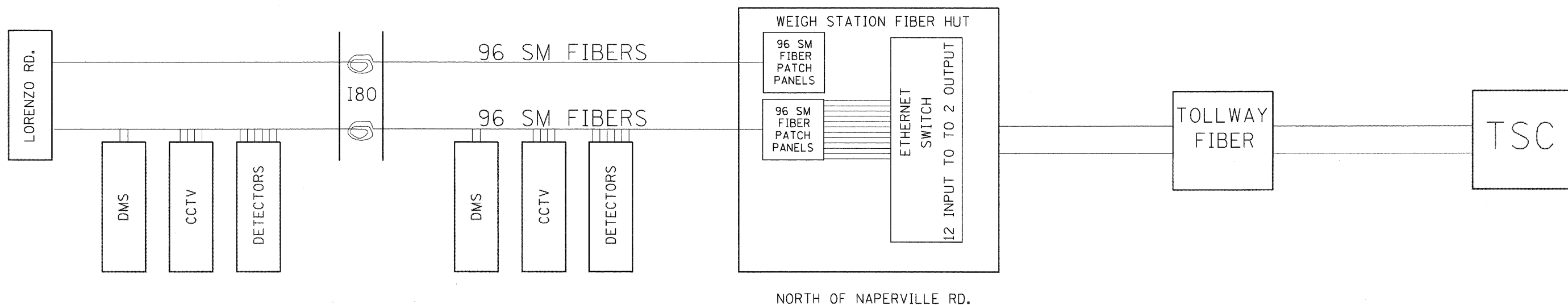

NORTH OF NAPERVILLE RD.

FILE NAME = C:\d106010\165TSC1YP.DGN	USER NAME = mezag	DESIGNED - J.G.	REVISED - 01/27/2010	STATE OF ILLINOIS DEPARTMENT OF TRANSPORTATION TRAFFIC SYSTEMS CENTER	FIBER ROUTE		F.A. RTE.	SECTION	COUNTY	TOTAL SHEETS	SHEET NO.	
C:\02092010 Submittal\180NAPERVTYP.dgn		DRAWN - G.M.	REVISED - 03/05/2010		SCALE: NONE	SHEET NO. OF SHEETS	STA. TO STA.	55	99-2HB-2B-1	WILL	756	452
PLDT SCALE = 100.0000' / IN.		CHECKED - J.G.	REVISED -						CONTRACT NO. 60F12			
PLDT DATE = 6/30/2010		DATE - 01/19/2010	REVISED -						FED. ROAD DIST. NO. 1 ILLINOIS FED. AID PROJECT			

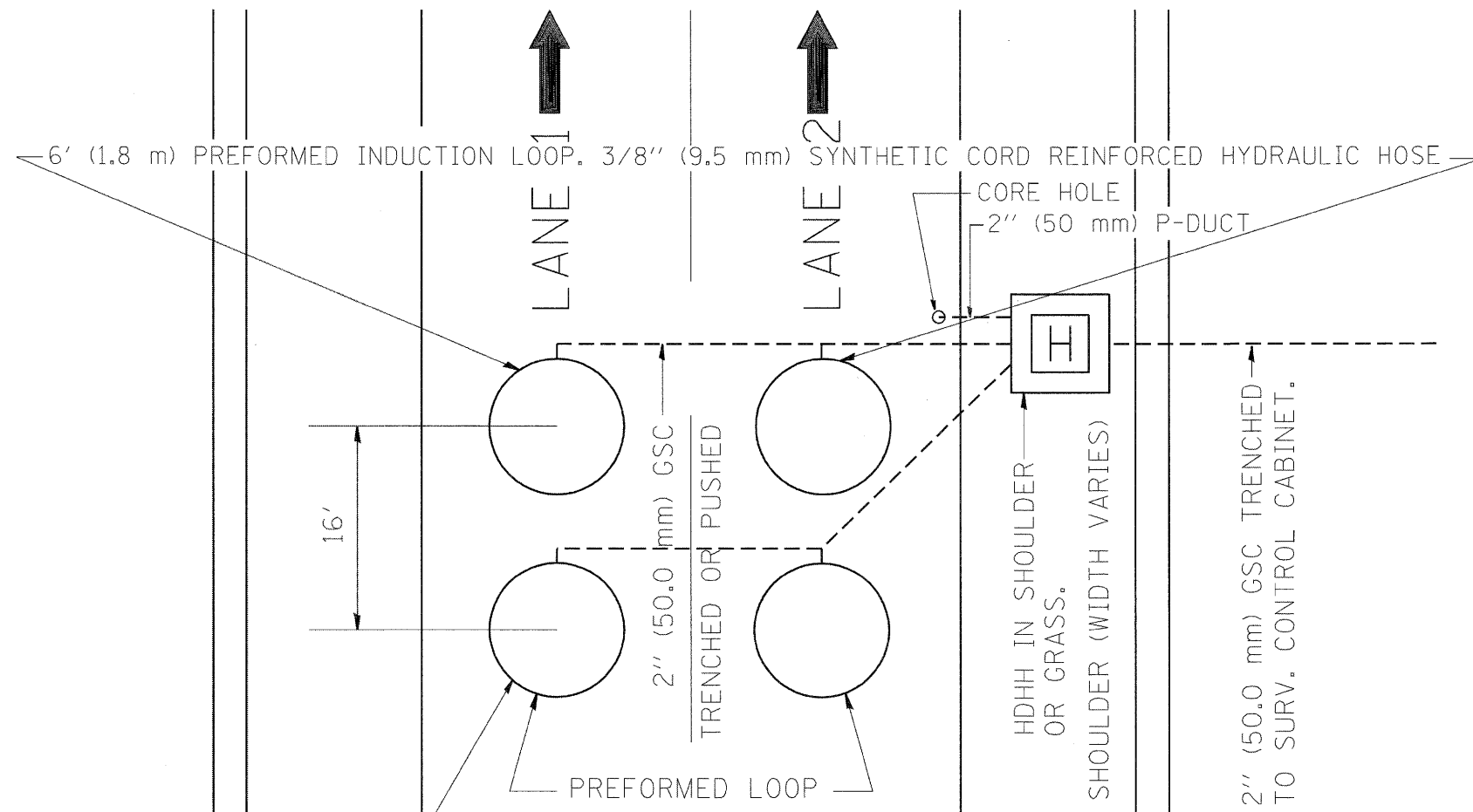

4 TURNS #14-7 STRAND XHHW XLP-600V LOOP WIRE UNLESS OTHERWISE NOTED IN PLANS.

TYPICAL 2 LANE SPEED COUNT, CLASSIFICATION STATION IN NEW CONCRETE PAVEMENT

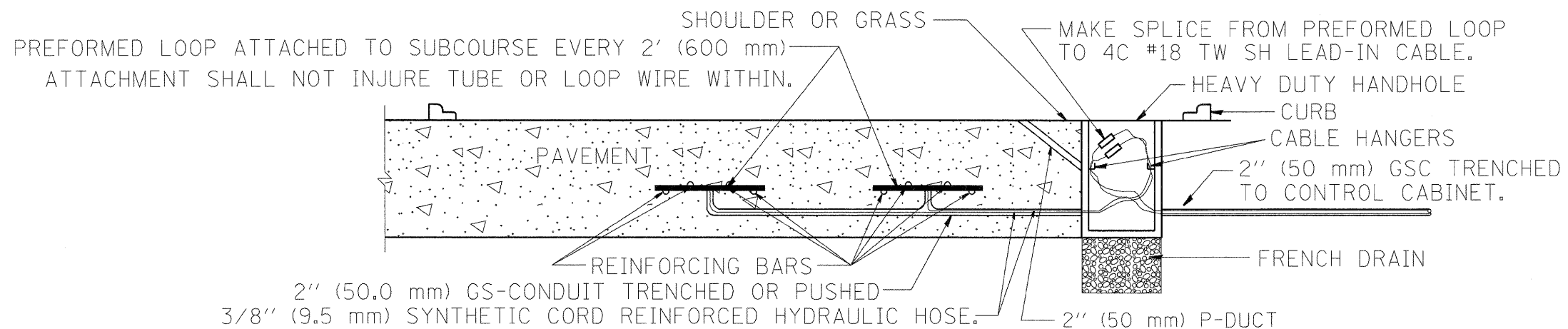

LOOP INSTALLATION IN NEW CONCRETE PAVEMENT

NOTES:

- 1.- EACH INDUCTION LOOP SHALL HAVE ITS OWN 4C #18 TWISTED SHIELD LEAD-IN CABLE TO CABINET.
- 2.- INDUCTION LOOPS SHALL NOT BE CONNECTED IN SERIES WITH OTHER LOOPS.
- 3.- LOOPS LOCATED OVER 1000' (300 m) FROM CABINET SHALL REQUIRE 5 TURNS OF #14 WIRE.
- 4.- FOR LANE 1 WRAP LOOPS CLOCKWISE, FOR LANE 2 WRAP LOOP COUNTER CLOCKWISE.
- 5.- COREHOLE SHALL BE FILLED WITH DUCT SEAL. JOINT SEALER (OZ GEDNEY DOZSEAL 230 OR BETTER) SHALL BE ADDED AFTER DUCT SEAL.

FILE NAME =	USER NAME = mezag	DESIGNED - J.G.	REVISED - 07/01/2010	STATE OF ILLINOIS DEPARTMENT OF TRANSPORTATION TRAFFIC SYSTEMS CENTER	PREFORMED LOOP TYPICAL INSTALLATION NEW CONCRETE PAVEMENT				F.A. RTE.	SECTION	COUNTY	TOTAL SHEETS	SHEET NO.		
C:\Projects\TSC\TYPICALS\TSC\TYP08.dgn		DRAWN - G.M.	REVISED -		SCALE: NONE	SHEET NO.	OF	SHEETS	STA.	TO STA.	55	99-2HB-2B-1	WILL	756	454
		CHECKED - J.G.	REVISED -												
		DATE - 06/25/2010	REVISED -												
										CONTRACT NO. 60F12					
										FED. ROAD DIST. NO. 1 ILLINOIS FED. AID PROJECT					

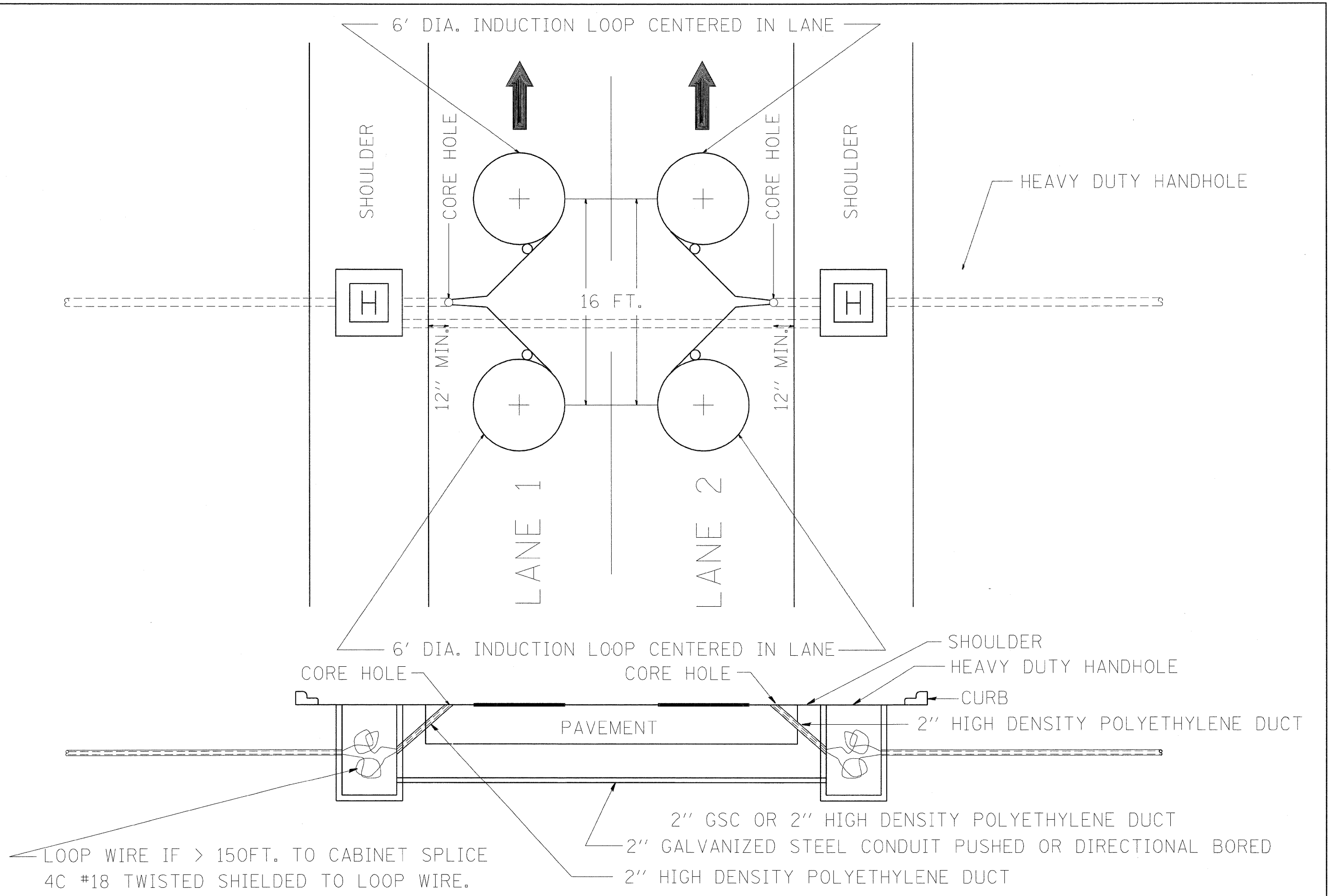

LOOP WIRE IF > 150FT. TO CABINET SPLICE
4C #18 TWISTED SHIELDED TO LOOP WIRE.

FILE NAME = C:\Projects\TSC\TYPICALS\TSCYP08.dgn	USER NAME = mezag	DESIGNED - J.G.	REVISED -	STATE OF ILLINOIS DEPARTMENT OF TRANSPORTATION TRAFFIC SYSTEMS CENTER	TRAFFIC SURVEILLANCE 2 LANE SPEED, COUNT, CLASSIFICATION STATION			F.A. RTE. 55	SECTION 99-2HB-2B-1	COUNTY WILL	TOTAL SHEETS 756	SHEET NO. 455
	PLOT SCALE = 100.0000' / IN.	CHECKED - J.G.	REVISED -		SCALE: NONE	SHEET NO. OF SHEETS	STA. TO STA.	CONTRACT NO. 60F12				
	PLOT DATE = 7/2/2010	DATE - 06/25/2010	REVISED -		FED. ROAD DIST. NO. 1 ILLINOIS FED. AID PROJECT							
TRAFFIC SYSTEMS CENTER (TY-1TSC-418#21)												

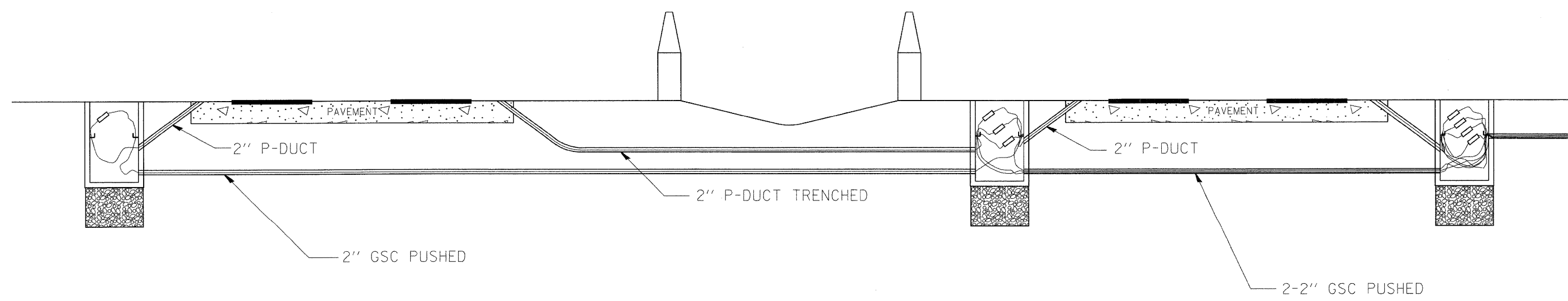
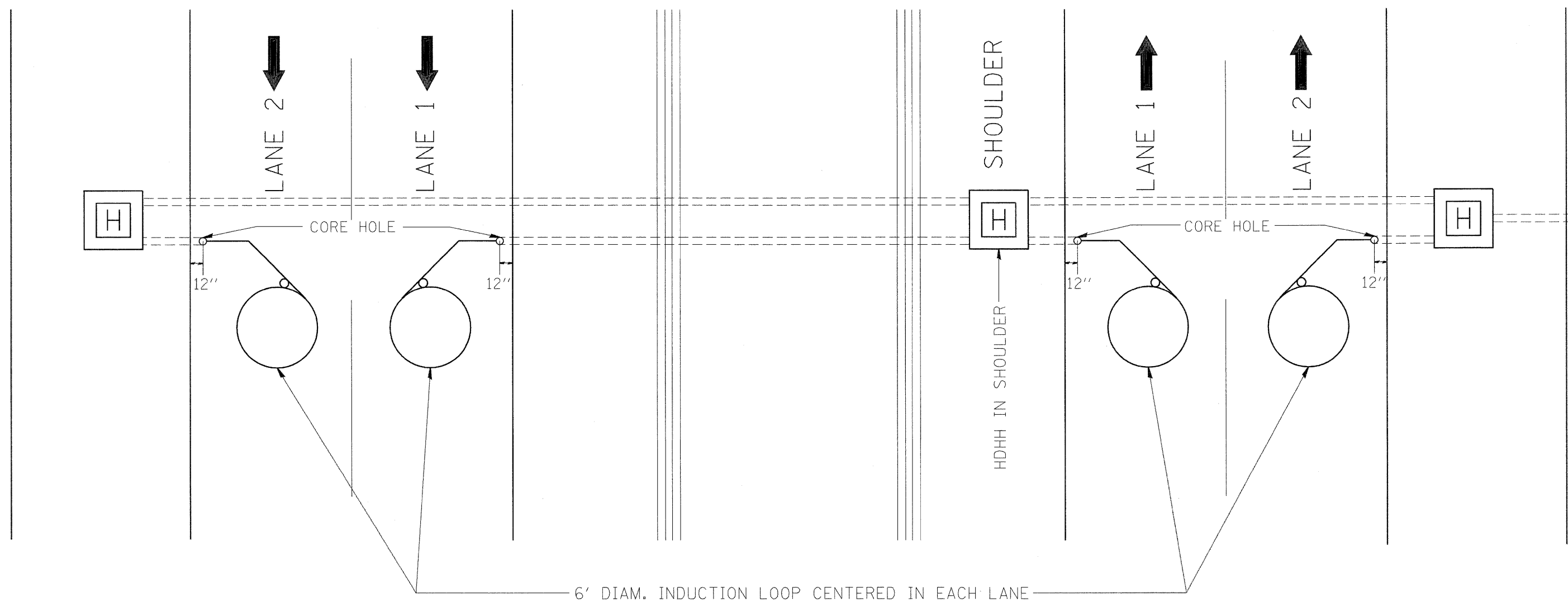

FILE NAME =	USER NAME = mezag	DESIGNED - J.G.	REVISED -
C:\Projects\TSC\TYPICALS\TSC\TYP08.dgn		DRAWN - G.M.	REVISED -
	PLOT SCALE = 100.0000' / IN.	CHECKED - J.G.	REVISED -
	PLOT DATE = 7/2/2010	DATE - 07/01/2010	REVISED -



















STATE OF ILLINOIS
DEPARTMENT OF TRANSPORTATION
 TRAFFIC SYSTEMS CENTER

TRAFFIC SURVEILLANCE TWO LANE COUNT STATION			
SCALE: NONE	SHEET NO.	OF SHEETS	STA. TO STA.

F.A. RTE.	SECTION	COUNTY	TOTAL SHEETS	SHEET NO.
55	99-2HB-2B-1	WILL	756	456
CONTRACT NO. 60F12				
FED. ROAD DIST. NO. 1 ILLINOIS FED. AID PROJECT				

SYMBOL

LEGEND

-  RAMP INDUCTION LOOP
-  COUNT, CLASSIFICATION, SPEED RAMP INDUCTION LOOPS
-  6 FT. DIAMETER INDUCTION LOOP CENTERED IN LANE
-  6 FT. DIAMETER COUNT, CLASSIFICATION, SPEED INDUCTION LOOPS
-  CCTV CAMERA
-  TYPE 334 CABINET
-  TELEPHONE SERVICE
-  ELECTRIC SERVICE DISCONNECT
-  JUNCTION BOX
-  HEAVY DUTY HAND HOLE (HDHH)
-  COMMUNICATION VAULT
-  GALVANIZED RIGID STEEL CONDUIT PUSHED (P), TYPE AND SIZE AS NOTED
-  (2) 1 1/4 IN. FIBER OPTIC INNER DUCT - EACH HAS 96 SM FIBERS
-  POLYETHYLENE DUCT
-  GALVANIZED STEEL CONDUIT
-  (E) EXISTING
-  P PUSHED
-  T TRENCHED
-  B.R. BEDROCK REMOVAL IN CUBIC YARDS

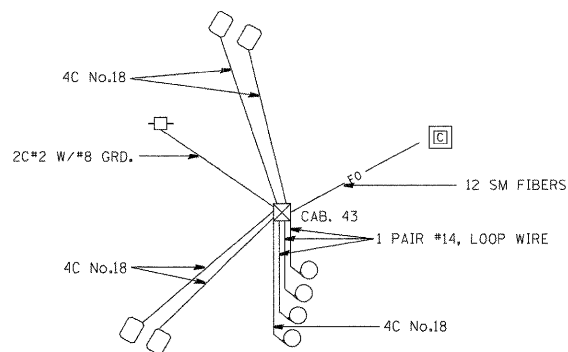

WIRING DIAGRAM

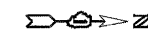

MATCHLINE 1017+00

MATCHLINE 1032+00

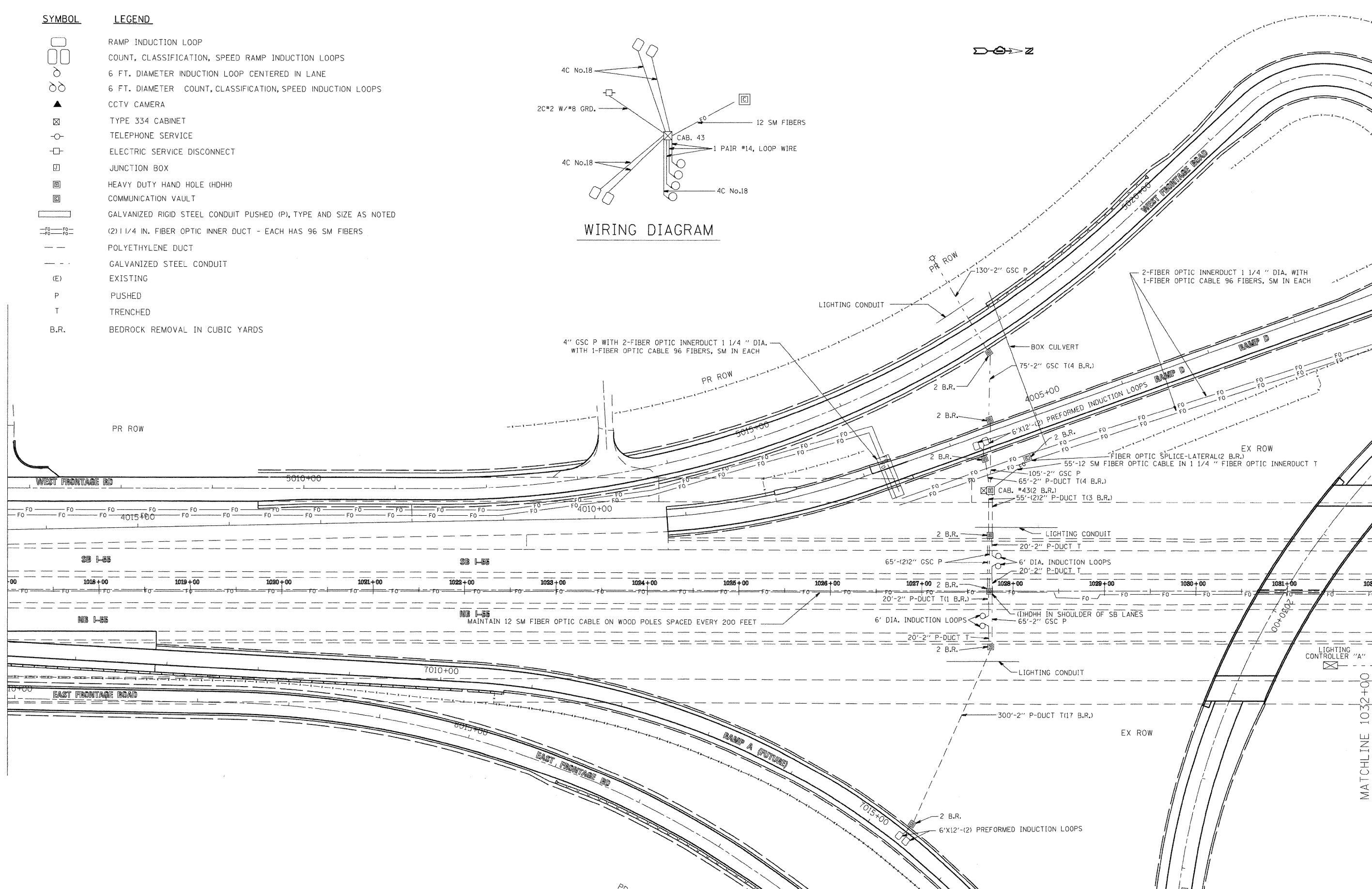

FILE NAME = C:\156 AT ARSENAL RD SHEETS.DGN	USER NAME = mezag	DESIGNED - J.G.	REVISED -	STATE OF ILLINOIS DEPARTMENT OF TRANSPORTATION TRAFFIC SYSTEMS CENTER	TRAFFIC SURVEILLANCE SOUTH ARSENAL RD. INTERCHANGE	F.A. RTE. 55	SECTION 99-21B-2B-3	COUNTY WILL	TOTAL SHEETS 756	SHEET NO. 458	
C:\156 AT ARSENAL RD\SHEETS.dgn					SCALE: _____	SHEET NO. _____ OF _____ SHEETS	STA. _____ TO STA. _____		CONTRACT NO. 60F12		
PLOT SCALE = 100.0000' / IN.					ILLINOIS FED. AID PROJECT						
PLOT DATE = 7/2/2010											

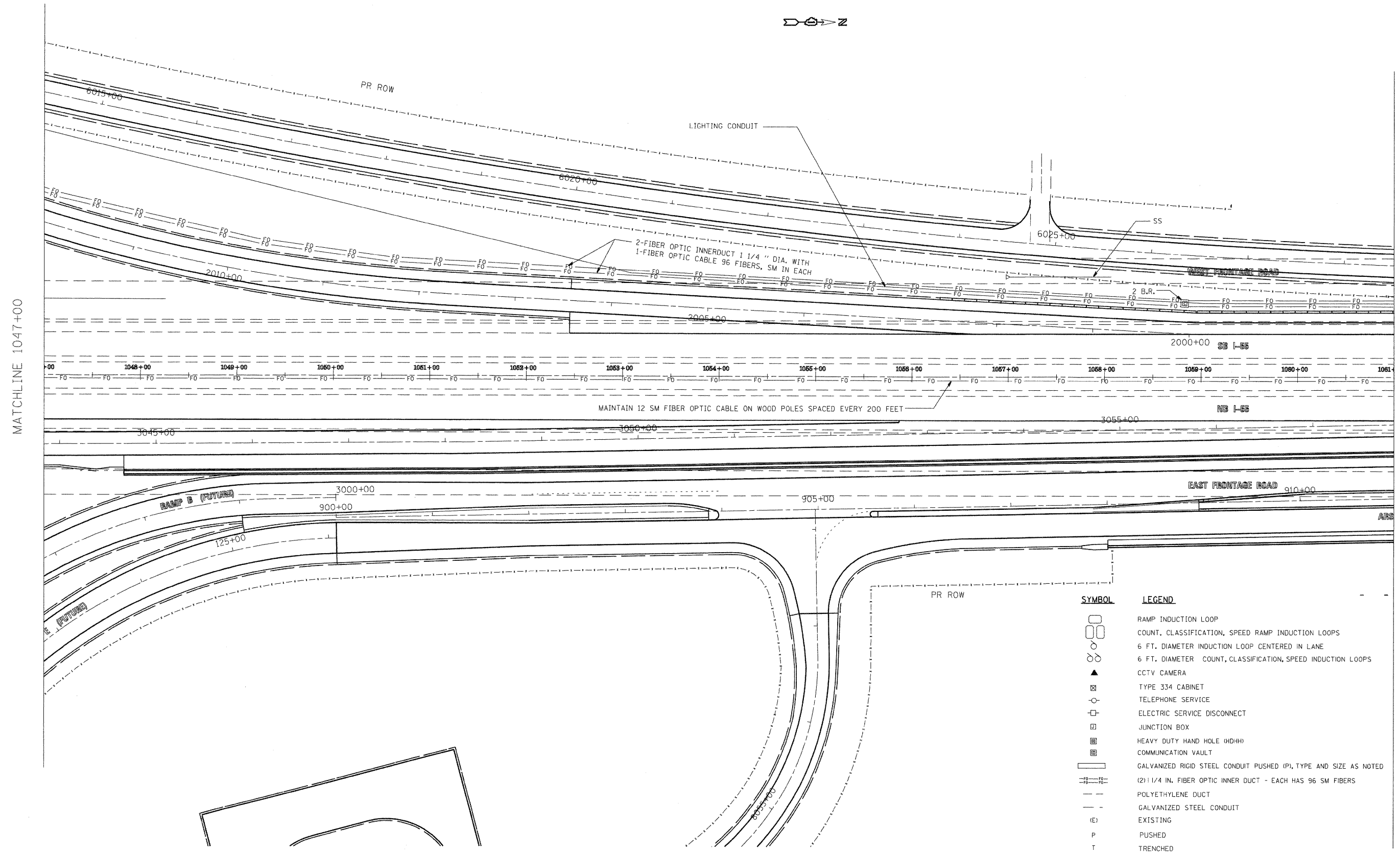
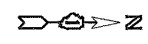

MATCHLINE 1047+00

MATCHLINE 1061+00

SYMBOL	LEGEND
	RAMP INDUCTION LOOP
	COUNT, CLASSIFICATION, SPEED RAMP INDUCTION LOOPS
	6 FT. DIAMETER INDUCTION LOOP CENTERED IN LANE
	6 FT. DIAMETER COUNT, CLASSIFICATION, SPEED INDUCTION LOOPS
	CCTV CAMERA
	TYPE 334 CABINET
	TELEPHONE SERVICE
	ELECTRIC SERVICE DISCONNECT
	JUNCTION BOX
	HEAVY DUTY HAND HOLE (HDH)
	COMMUNICATION VAULT
	GALVANIZED RIGID STEEL CONDUIT PUSHED (P), TYPE AND SIZE AS NOTED
	(2) 1/4 IN. FIBER OPTIC INNER DUCT - EACH HAS 96 SM FIBERS
	POLYETHYLENE DUCT
	GALVANIZED STEEL CONDUIT
	EXISTING
	PUSHED
	TRENCHED
	BEDROCK REMOVAL IN CUBIC YARDS

FILE NAME = C:\155 AT ARSENAL RD SHEETS.DGN	USER NAME = mezag	DESIGNED - J.G.	REVISED -	STATE OF ILLINOIS DEPARTMENT OF TRANSPORTATION TRAFFIC SYSTEMS CENTER	TRAFFIC SURVEILLANCE STA. 1047+00 TO STA. 1061+00	F.A. RTE. - 55	SECTION - 99-2NB-2B-1	COUNTY - WILL	TOTAL SHEETS - 756	SHEET NO. - 460	
C:\155 AT ARSENAL RD\SHEETS.dgn	PLOT SCALE = 100.0000' / IN.	DRAWN - G.M.	REVISED -			SCALE: _____	SHEET NO. ___ OF ___ SHEETS	STA. _____ TO STA. _____	CONTRACT NO. 60F12		
	PLOT DATE = 7/2/2010	CHECKED - J.G.	REVISED -			1 ILLINOIS FED. AID PROJECT					
		DATE - 03/16/2010	REVISED -								

SYMBOL	LEGEND
	RAMP INDUCTION LOOP
	COUNT, CLASSIFICATION, SPEED RAMP INDUCTION LOOPS
	6 FT. DIAMETER INDUCTION LOOP CENTERED IN LANE
	6 FT. DIAMETER COUNT, CLASSIFICATION, SPEED INDUCTION LOOPS
	CCTV CAMERA
	TYPE 334 CABINET
	TELEPHONE SERVICE
	ELECTRIC SERVICE DISCONNECT
	JUNCTION BOX
	HEAVY DUTY HAND HOLE (HDHH)
	COMMUNICATION VAULT
	GALVANIZED RIGID STEEL CONDUIT PUSHED (P), TYPE AND SIZE AS NOTED
	(2) 1/4 IN. FIBER OPTIC INNER DUCT - EACH HAS 96 SM FIBERS
	POLYETHYLENE DUCT
	GALVANIZED STEEL CONDUIT
	EXISTING
	PUSHED
	TRENCHED
	B.R. BEDROCK REMOVAL IN CUBIC YARDS



MATCHLINE 1061+00

MATCHLINE 1076+00

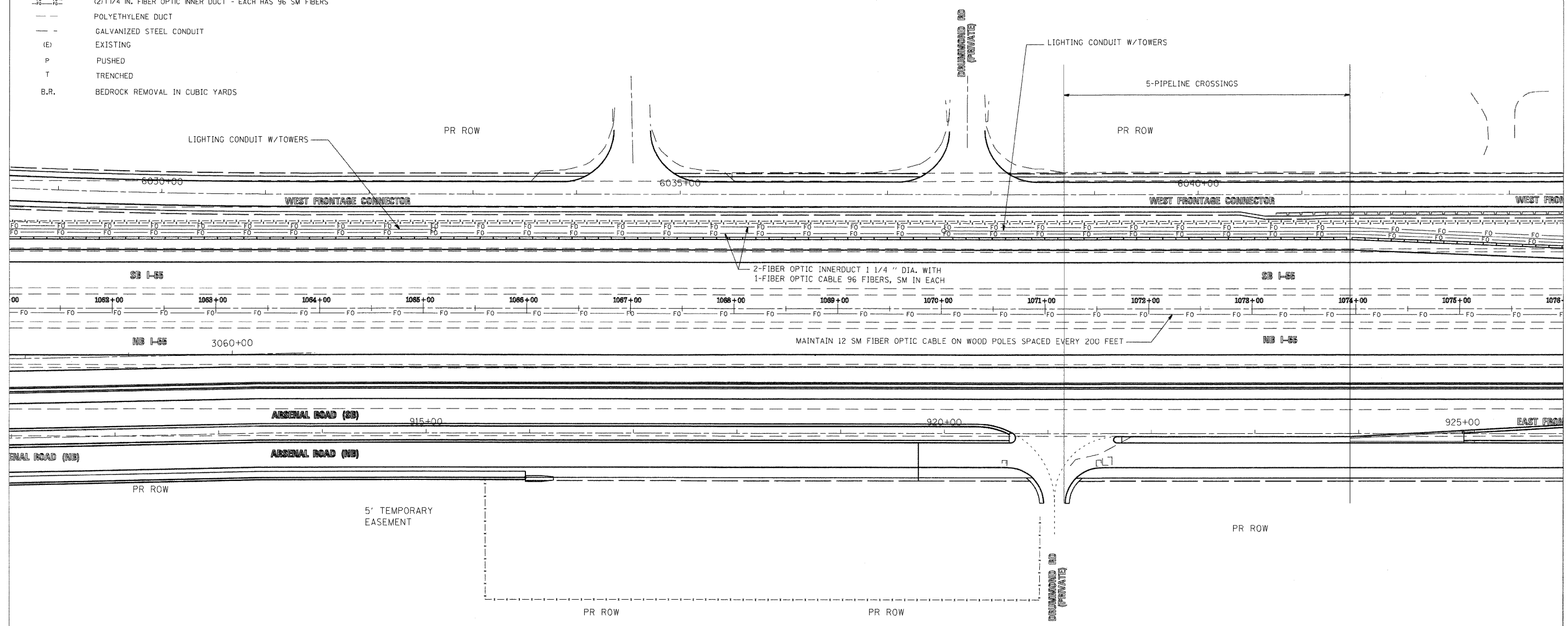

FILE NAME = G:\195 AT ARSENAL RD SHEETS.DGN	USER NAME = mezag	DESIGNED - J.G.	REVISED -	STATE OF ILLINOIS DEPARTMENT OF TRANSPORTATION TRAFFIC SYSTEMS CENTER	TRAFFIC SURVEILLANCE STA. STA. 1061+00 TO STA. 1076+00	F.A. RTE. 55	SECTION 99-2HB-2B-1	COUNTY WILL	TOTAL SHEETS 756	SHEET NO. 461		
C:\195 AT ARSENAL RD\SHEETS.dgn	PLOT SCALE = 100.0000' / 1" IN.	CHECKED - J.G.	REVISED -			SCALE: _____	SHEET NO. _____ OF _____ SHEETS	CONTRACT NO. 60F12	1 ILLINOIS FED. AID PROJECT			
	PLOT DATE = 7/2/2010	DATE - 03/16/2010	REVISED -									

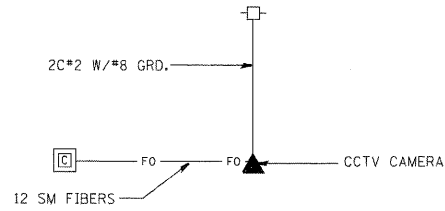

WIRING DIAGRAM

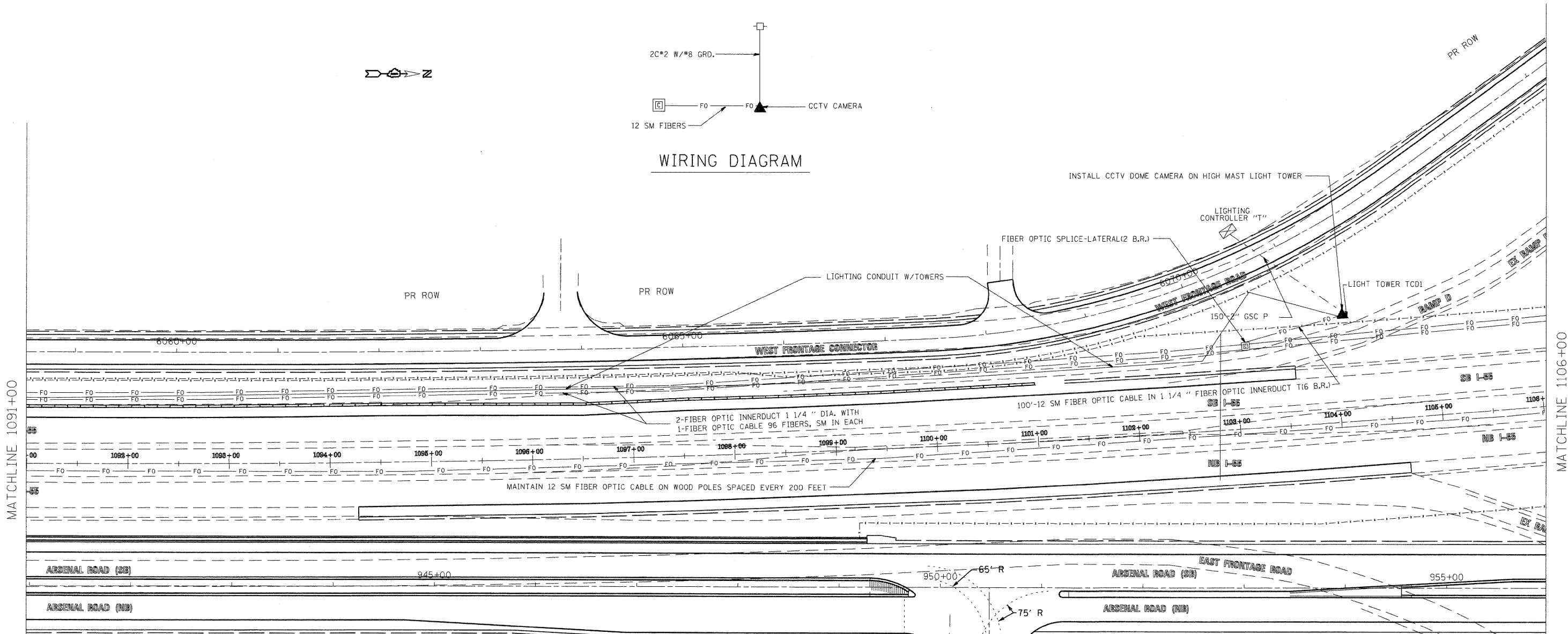

SYMBOL	LEGEND
	RAMP INDUCTION LOOP
	COUNT, CLASSIFICATION, SPEED RAMP INDUCTION LOOPS
	6 FT. DIAMETER INDUCTION LOOP CENTERED IN LANE
	6 FT. DIAMETER COUNT, CLASSIFICATION, SPEED INDUCTION LOOPS
	CCTV CAMERA
	TYPE 334 CABINET
	TELEPHONE SERVICE
	ELECTRIC SERVICE DISCONNECT
	JUNCTION BOX
	HEAVY DUTY HAND HOLE (HDHH)
	COMMUNICATION VAULT
	GALVANIZED RIGID STEEL CONDUIT PUSHED (P), TYPE AND SIZE AS NOTED
	(2) 1/4 IN. FIBER OPTIC INNER DUCT - EACH HAS 96 SM FIBERS
	POLYETHYLENE DUCT
	GALVANIZED STEEL CONDUIT
(E)	EXISTING
P	PUSHED
T	TRENCHED
B.R.	BEDROCK REMOVAL IN CUBIC YARDS

FILE NAME = C:\ISS AT ARSENAL RD SHEETS.DGN
 C:\ISS AT ARSENAL RD\SHEETS.dgn

USER NAME = mezag	DESIGNED - J.G.	REVISED -
DRAWN - C.M.	REVISOR -	DATE -
CHECKED - J.G.	REVISOR -	DATE -
DATE - 03/16/2010	REVISOR -	DATE -

STATE OF ILLINOIS
 DEPARTMENT OF TRANSPORTATION
 TRAFFIC SYSTEMS CENTER

TRAFFIC SURVEILLANCE
 STA. 1091+00 TO STA. 1106+00

SCALE: _____ SHEET NO. ____ OF ____ SHEETS STA. _____ TO STA. _____

F.A. RTE.	SECTION	COUNTY	TOTAL SHEETS	SHEET NO.
.55	99-2HB-2B-1	WILL	756	463
CONTRACT NO. 60F12			1 ILLINOIS FED. AID PROJECT	



SYMBOL	LEGEND
	RAMP INDUCTION LOOP
	COUNT, CLASSIFICATION, SPEED RAMP INDUCTION LOOPS
	6 FT. DIAMETER INDUCTION LOOP CENTERED IN LANE
	6 FT. DIAMETER COUNT, CLASSIFICATION, SPEED INDUCTION LOOPS
	CCTV CAMERA
	TYPE 334 CABINET
	TELEPHONE SERVICE
	ELECTRIC SERVICE DISCONNECT
	JUNCTION BOX
	HEAVY DUTY HAND HOLE (HDHH)
	COMMUNICATION VAULT
	GALVANIZED RIGID STEEL CONDUIT PUSHED (P), TYPE AND SIZE AS NOTED
	(2) 1 1/4 IN. FIBER OPTIC INNER DUCT - EACH HAS 96 SM FIBERS
	POLYETHYLENE DUCT
	GALVANIZED STEEL CONDUIT
	EXISTING
	PUSHED
	TRENCHED
	B.R. BEDROCK REMOVAL IN CUBIC YARDS

WIRING DIAGRAM

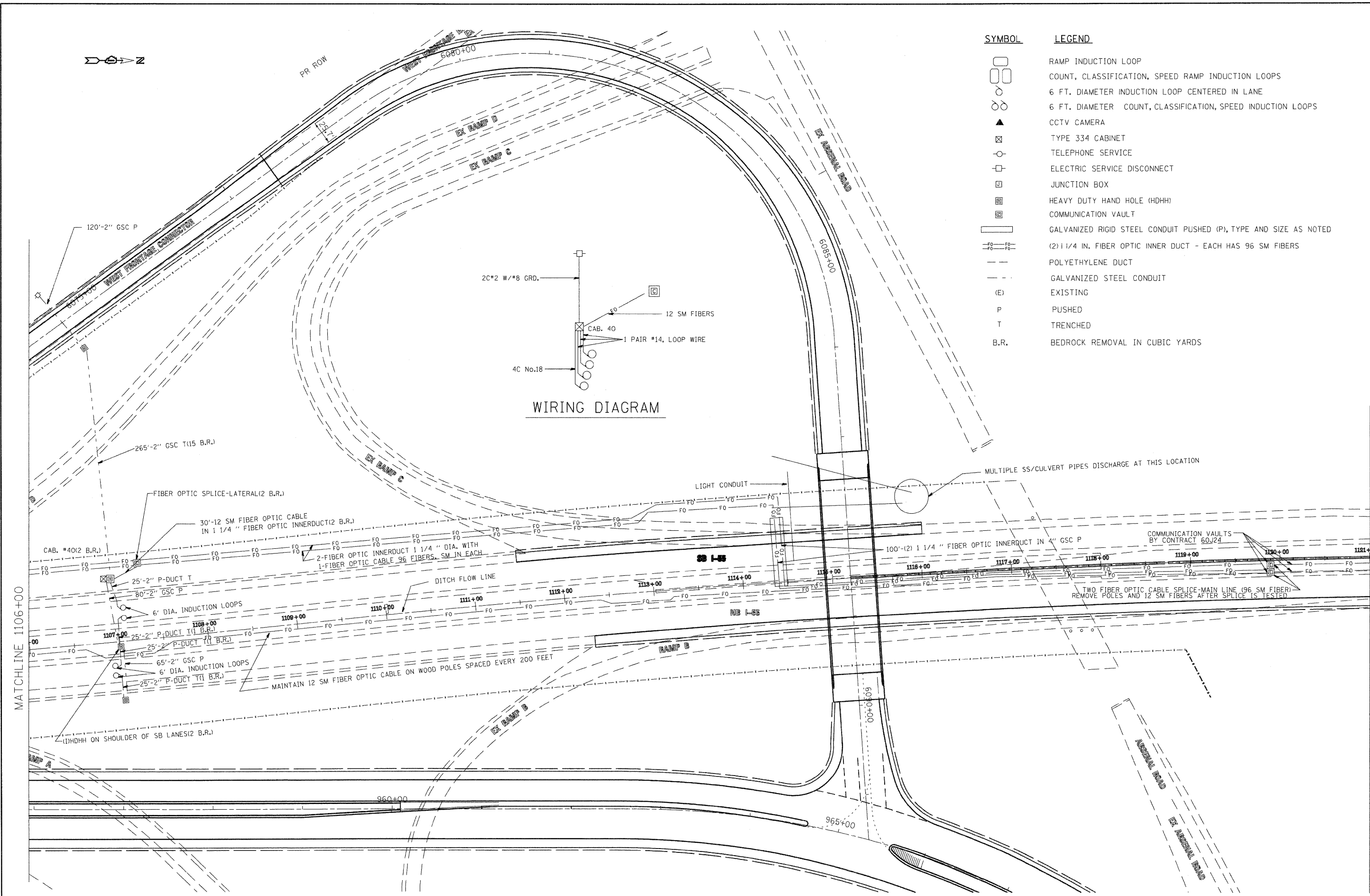
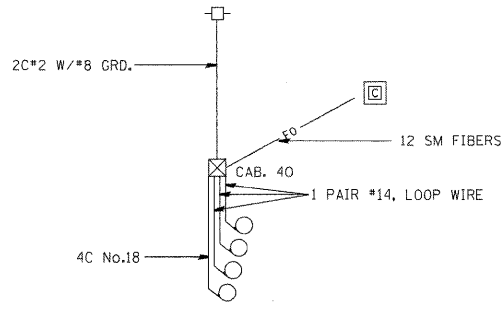

FILE NAME = C:\155 AT ARSENAL RD\SHEETS.DGN	USER NAME = mezag	DESIGNED - J.G.	REVISED -	STATE OF ILLINOIS DEPARTMENT OF TRANSPORTATION TRAFFIC SYSTEMS CENTER	TRAFFIC SURVEILLANCE SOUTH OF DES PLAINES RIVER		F.A. RTE. - 55	SECTION - 99-2HB-2B-1	COUNTY - WILL	TOTAL SHEETS - 756	SHEET NO. - 464
CONTRACT NO. 60F12	SCALE: _____	CHECKED - J.C.	REVISED -		SHEET NO. _____ OF _____ SHEETS	STA. _____ TO STA. _____	1 ILLINOIS FED. AID PROJECT				
PLLOT DATE = 7/2/2010	DATE - 03/16/2010	REVISIION -	REVISED -								

Bench Mark: RR spike in 2nd power pole N. of CPT 207, 1 ft. above ground, Elev. 534.690
Existing Structure: None

STATE OF ILLINOIS
 DEPARTMENT OF TRANSPORTATION

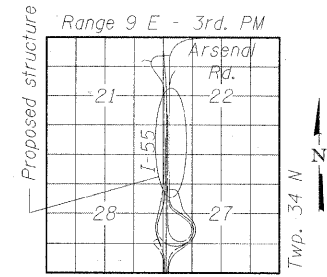

LOCATION SKETCH

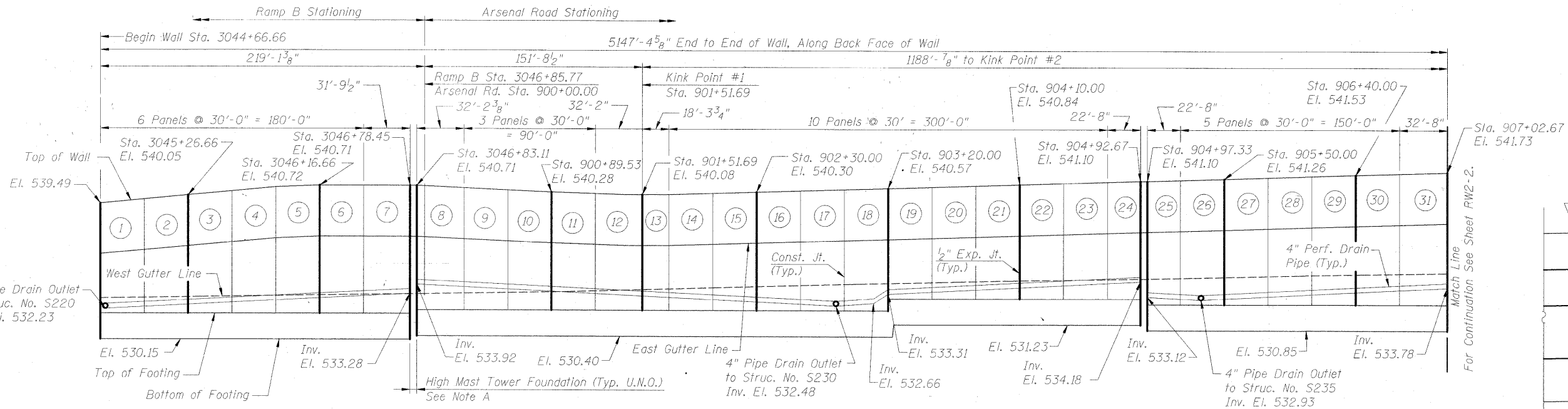

ELEVATION
 (Looking at Back Face of Wall)

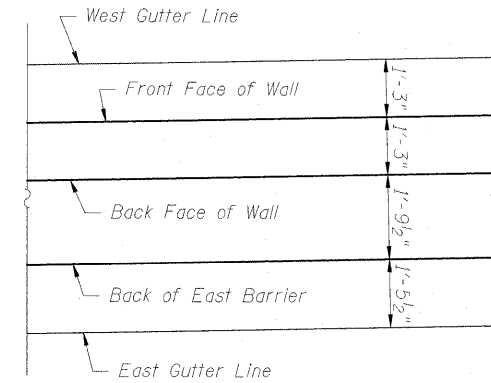

DETAIL A

Typ., see sheets RW2-14 & RW2-15 for sections.

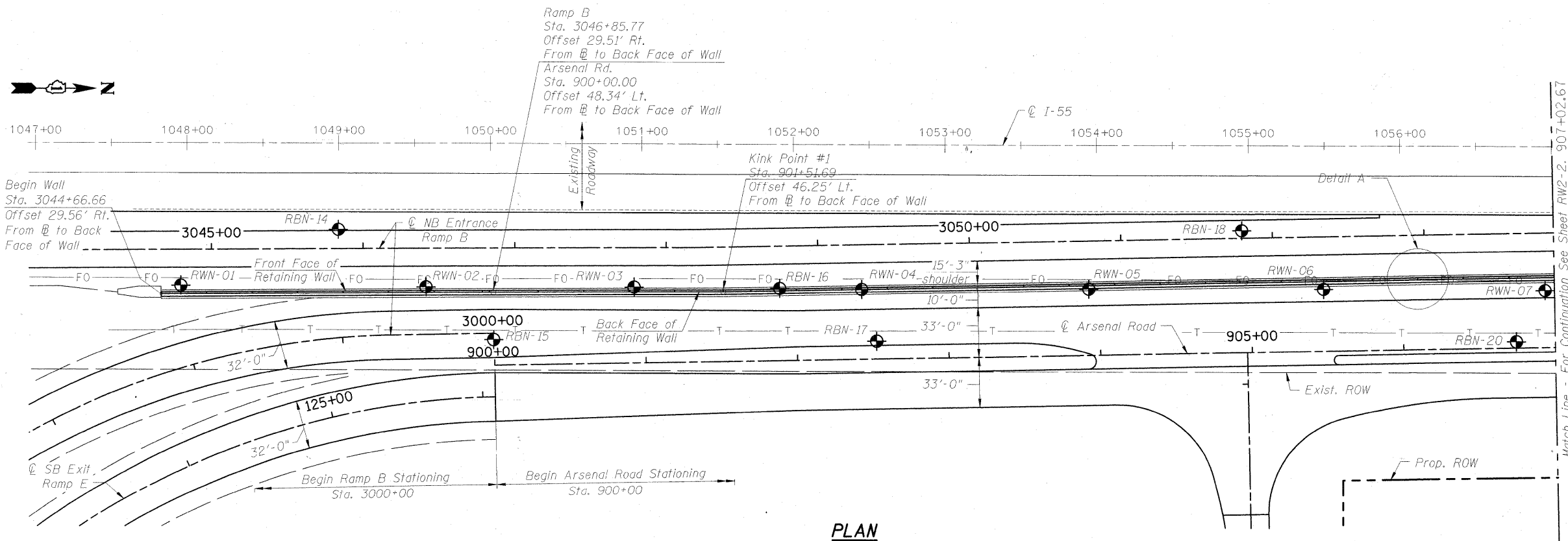

PLAN

NOTES:

- Offsets are measured from the $\text{\textcircled{C}}$ of Arsenal Rd., u.n.o.
- Construction joints shall be placed at 30' on center and expansion joints shall be placed at 90' on center, u.n.o.

LEGEND:

- $\text{\textcircled{+}}$ = Soil Boring
- $\text{\textcircled{1}}$ = Panel No.

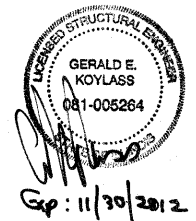

GENERAL PLAN & ELEVATION - 1
 SECTION NO. (99-1&2) R-6
 WILL COUNTY
 STATION 3044+66.66 TO 949+27.33
 STRUCTURE NO. 099-W027

DESIGNED	PMH
CHECKED	MJL
DRAWN	PMH
CHECKED	BB

Note A:
 For high mast tower foundation details see sheets S-1 to S-4.

McDonough Associates Inc.
 Engineers / Architects
 130 East Randolph Street
 Chicago, Illinois 60601
 (312) 946-8600

SHEET NO. RW2-1 SHEETS RW2-31	F.A.I. RTE.	SECTION	COUNTY	TOTAL SHEETS	SHEET NO.
	55	(99-1&2) R-6	WILL	756	465
FED. ROAD DIST. NO.			ILLINOIS FED. AID PROJECT		
CONTRACT NO. 60F12					

STATE OF ILLINOIS
DEPARTMENT OF TRANSPORTATION

5147'-4⁵/₈" End to End of Wall, Along Back Face of Wall

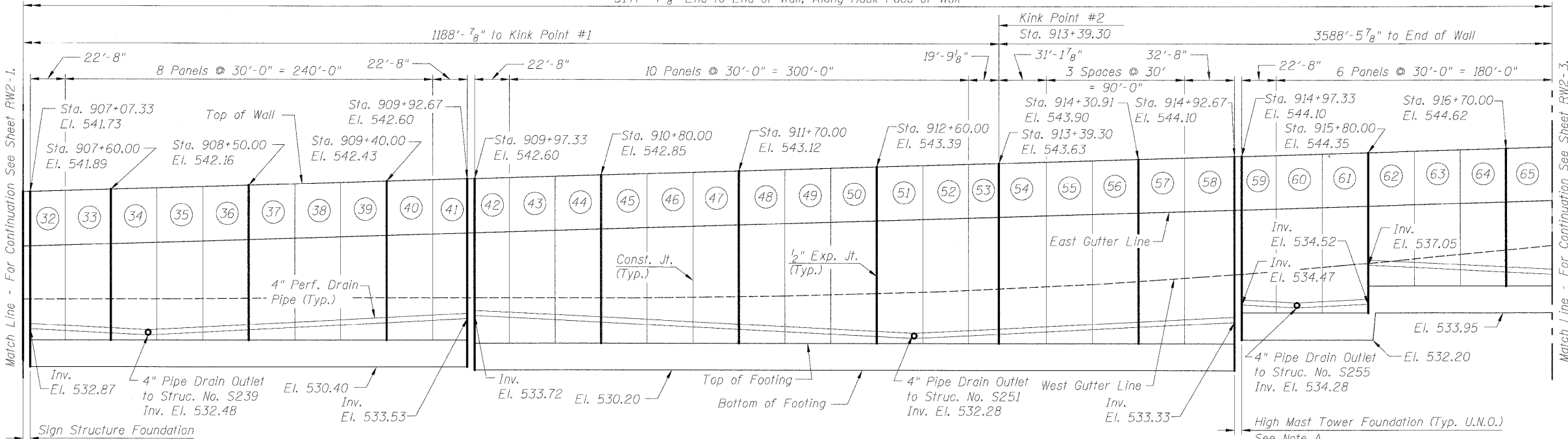

ELEVATION
(Looking at Back Face of Wall)

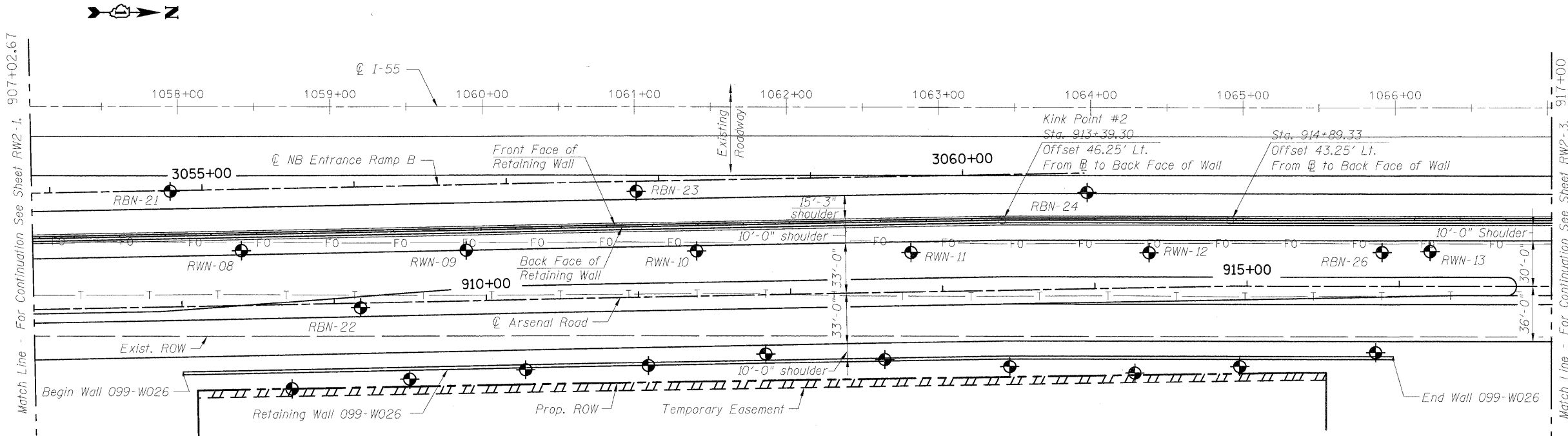

PLAN

- NOTES:**
- Offsets are measured from the \odot of Arsenal Rd. u.n.o.
 - Construction joints shall be placed at 30' on center and expansion joints shall be placed at 90' on center, u.n.o.

- LEGEND:**
- \bullet = Soil Boring
 - (1) = Panel No.

DESIGNED	PMH
CHECKED	MJL
DRAWN	PMH
CHECKED	BB

McDonough Associates Inc.
Engineers / Architects
130 East Randolph Street
Chicago, Illinois 60601
(312) 946-8600

SHEET NO. RW2-2 SHEETS RW2-31	F.A.I. RTE.	SECTION	COUNTY	TOTAL SHEETS	SHEET NO.
	55	(99-1&2) R-6	WILL	756	466
FED. ROAD DIST. NO.			ILLINOIS FED. AID PROJECT		
CONTRACT NO. 60F12					

GENERAL PLAN & ELEVATION-2
STRUCTURE NO. 099-W027

STATE OF ILLINOIS
DEPARTMENT OF TRANSPORTATION

5147'-4⁵/₈" End to End of Wall, Along Back Face of Wall

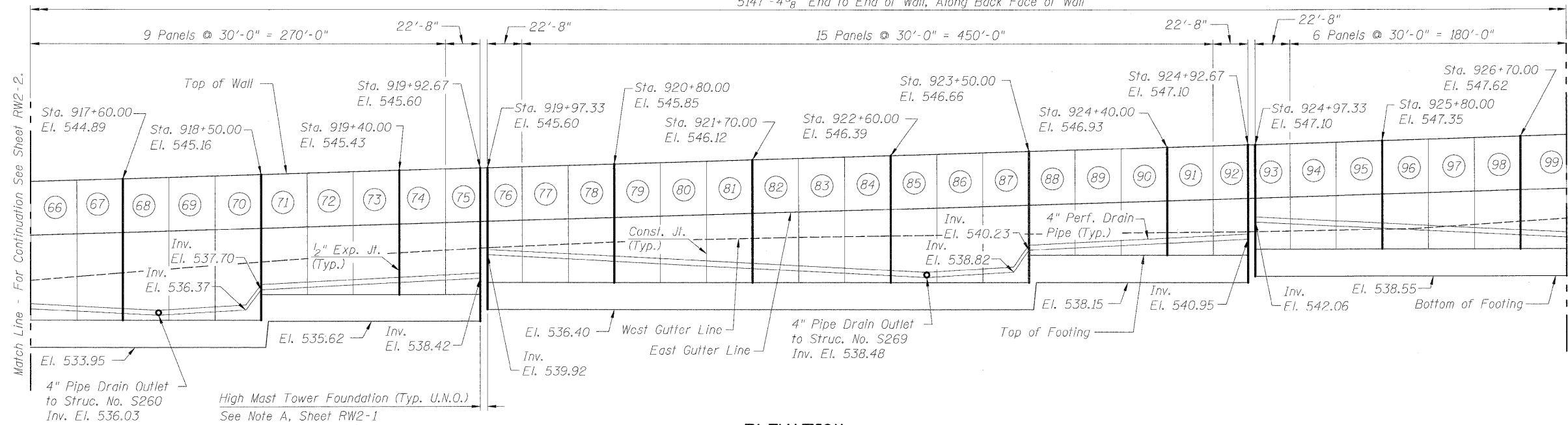

ELEVATION

(Looking at Back Face of Wall)

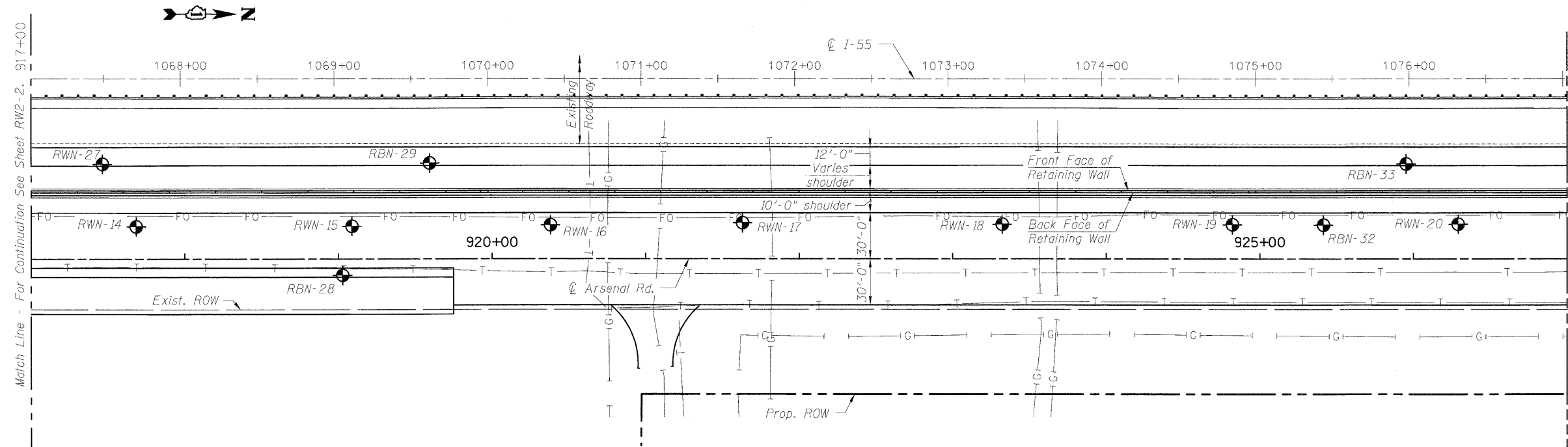

PLAN

NOTES:

- Offsets are measured from the C of Arsenal Rd., u.n.o.
- Construction joints shall be placed at 30' on center and expansion joints shall be placed at 90' on center, u.n.o.

LEGEND:

- ◆ = Soil Boring
- ① = Panel No.

DESIGNED	PMH
CHECKED	MJL
DRAWN	PMH
CHECKED	BB

McDonough Associates Inc.
Engineers / Architects
130 East Randolph Street
Chicago, Illinois 60601
(312) 946-8600

SHEET NO. RW2-3 SHEETS RW2-31	F.A.I. RTE.	SECTION	COUNTY	TOTAL SHEETS	SHEET NO.
	55	(99-1&2) R-6	WILL	756	467
FED. ROAD DIST. NO.			ILLINOIS FED. AID PROJECT		
CONTRACT NO. 60F12					

GENERAL PLAN & ELEVATION-3
STRUCTURE NO. 099-W027

STATE OF ILLINOIS
DEPARTMENT OF TRANSPORTATION

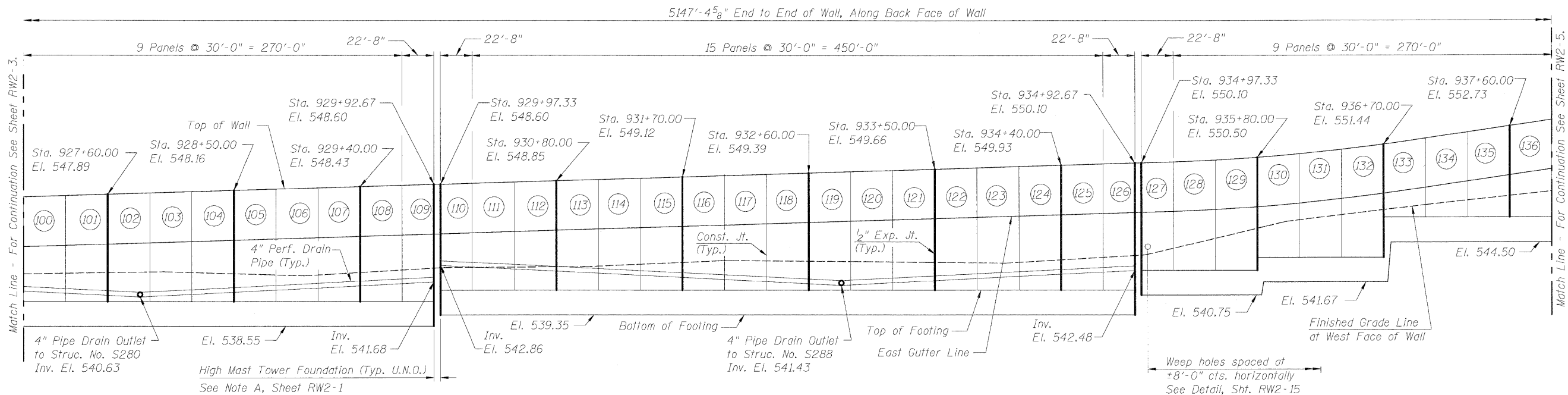

ELEVATION
(Looking at Back Face of Wall)

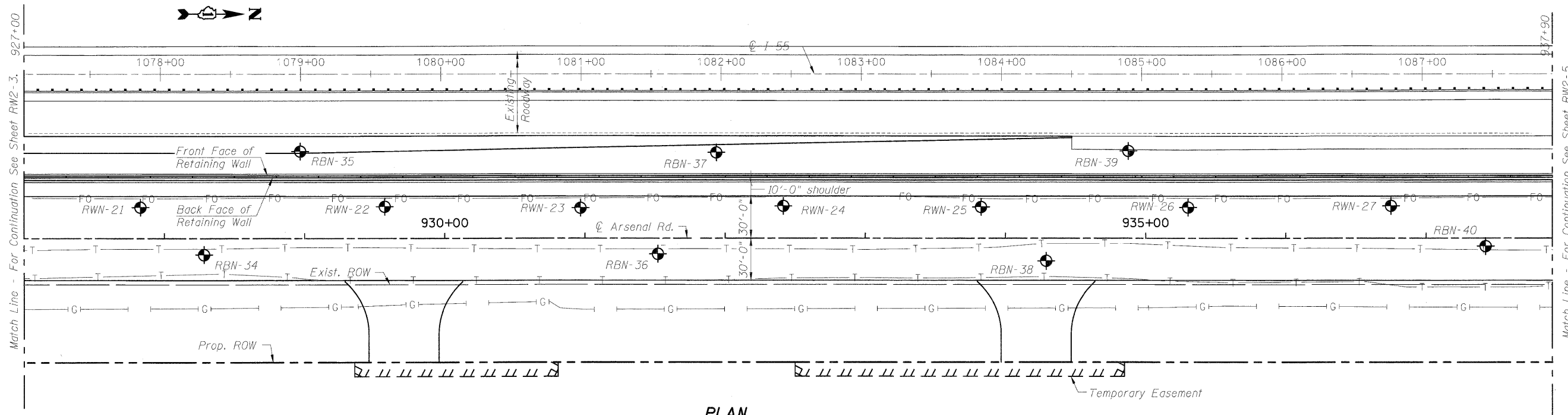

PLAN

NOTES:

- Offsets are measured from the ϕ of Arsenal Rd., u.n.o.
- Construction joints shall be placed at 30' on center and expansion joints shall be placed at 90' on center, u.n.o.

LEGEND:

- ⊕ = Soil Boring
- ① = Panel No.

DESIGNED	PMH
CHECKED	MJL
DRAWN	PMH
CHECKED	BB

McDonough Associates Inc.
Engineers / Architects
130 East Randolph Street
Chicago, Illinois 60601
(312) 946-8600

SHEET NO. RW2-4 SHEETS RW2-31	F.A.I. RTE.	SECTION	COUNTY	TOTAL SHEETS	SHEET NO.
	55	(99-1&2) R-6	WILL	756	468
FED. ROAD DIST. NO.			ILLINOIS FED. AID PROJECT		
CONTRACT NO. 60F12					

GENERAL PLAN & ELEVATION-4
STRUCTURE NO. 099-W027

STATE OF ILLINOIS
DEPARTMENT OF TRANSPORTATION

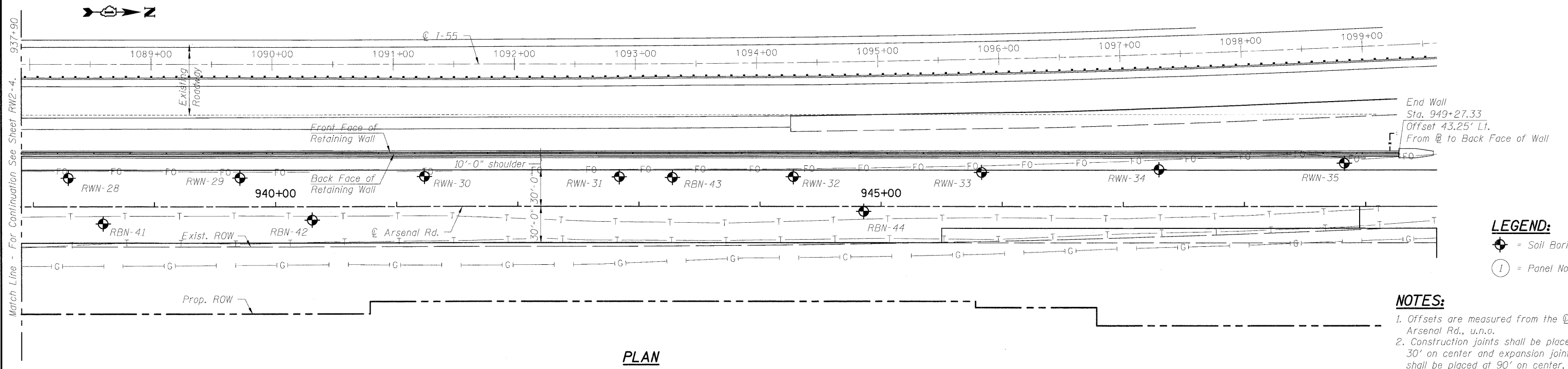
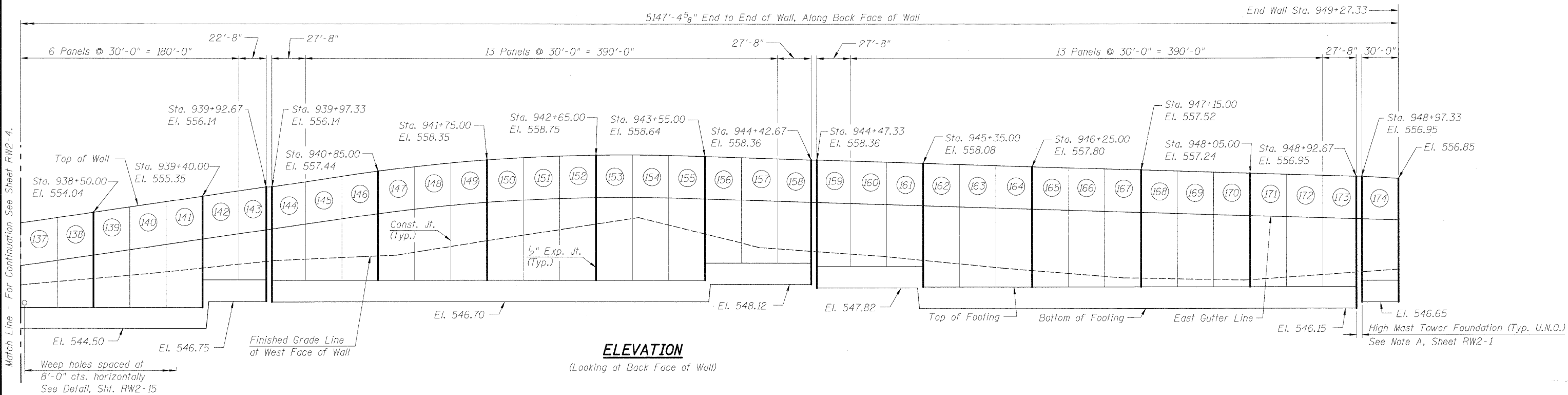

DESIGNED	PMH
CHECKED	MJL
DRAWN	PMH
CHECKED	BB

McDonough Associates Inc.
Engineers / Architects
130 East Randolph Street
Chicago, Illinois 60601
(312) 946-8600

SHEET NO. RW2-5 SHEETS RW2-31	F.A.I. RTE.	SECTION	COUNTY	TOTAL SHEETS	SHEET NO.
	55	(99-1&2) R-6	WILL	756	469
FED. ROAD DIST. NO.			ILLINOIS	FED. AID PROJECT	
CONTRACT NO. 60F12					

GENERAL PLAN & ELEVATION-5
STRUCTURE NO. 099-W027

STATE OF ILLINOIS
DEPARTMENT OF TRANSPORTATION

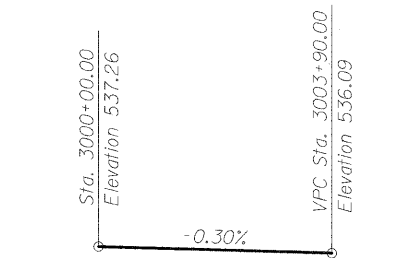

PROFILE GRADE - RAMP B
(Ramp East of Wall)

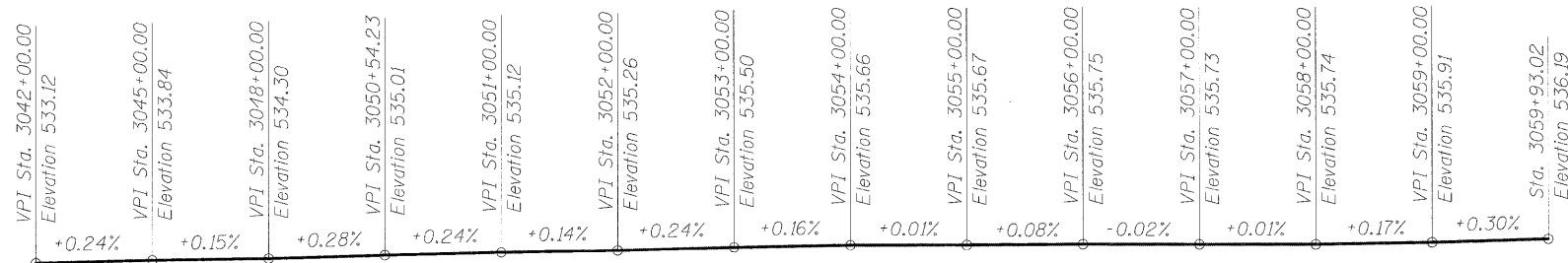

PROFILE GRADE - RAMP B
(Ramp West of Wall)

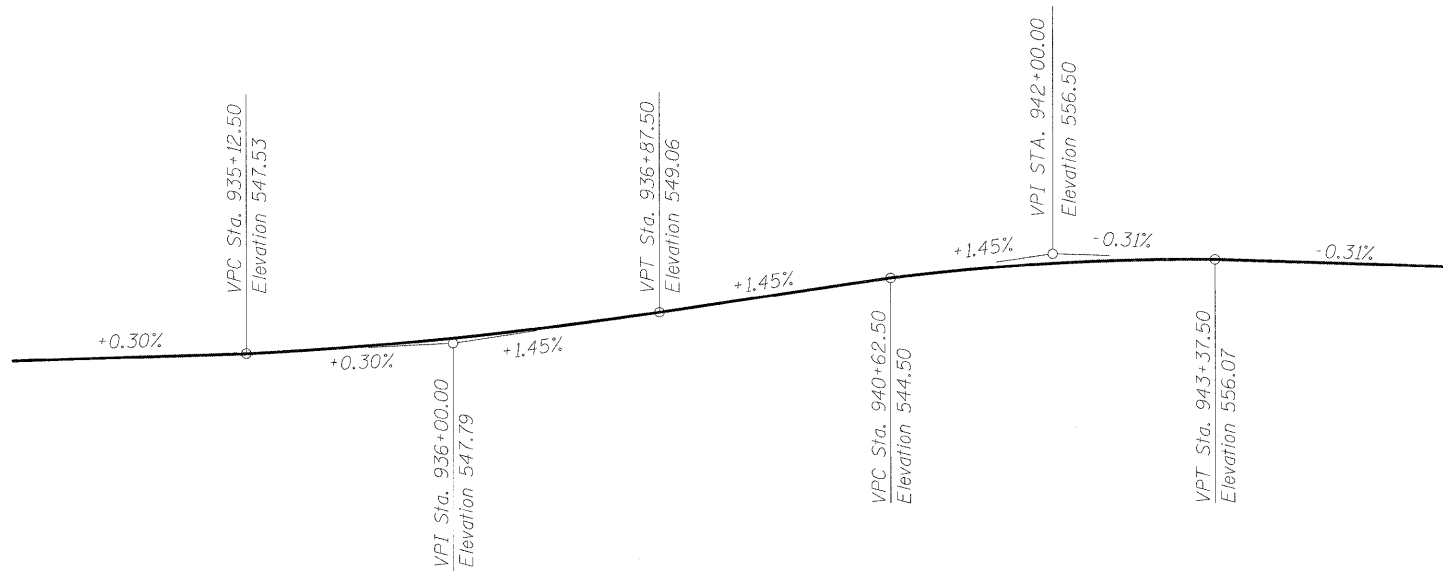

PROFILE GRADE - ARSENAL ROAD

INDEX OF SHEETS

1. General Plan & Elevation - 1
2. General Plan & Elevation - 2
3. General Plan & Elevation - 3
4. General Plan & Elevation - 4
5. General Plan & Elevation - 5
6. General Details & Bill of Material
7. Plan and Elevation - 1
8. Plan and Elevation - 2
9. Plan and Elevation - 3
10. Plan and Elevation - 4
11. Plan and Elevation - 5
12. Plan and Elevation - 6
13. Plan and Elevation - 7
14. Section and Details
15. Section and Details
16. Section and Details
17. Section and Details
18. Section and Details
19. Bill of Material
20. Soil Borings
21. Soil Borings
22. Soil Borings
23. Soil Borings
24. Soil Borings
25. Soil Borings
26. Soil Borings
27. Soil Borings
28. Soil Borings
29. Soil Borings
30. Soil Borings
31. Soil Borings

TOTAL BILL OF MATERIAL

ITEM	UNIT	TOTAL
Porous Granular Embankment	Cu Yd	3,889
Structure Excavation	Cu Yd	11,600
Rock Excavation for Structures	Cu Yd	2,440
Removal and Disposal of Unsuitable Material for Structures	Cu Yd	2,000
Concrete Structures	Cu Yd	5,399.6
Reinforcement Bars, Epoxy Coated	Pound	593,590
Geocomposite Wall Drain	Sq Yd	4,623
Pipe Drains 4"	Foot	33
Pipe Underdrains for Structures 4"	Foot	4,043

GENERAL NOTES

1. Reinforcement bars shall conform to the requirements of ASTM A 706 Gr 60. See Special Provisions.
2. Reinforcement bars designated (E) shall be epoxy coated.
3. Construction joints shall be bonded.
4. The back face of Retaining Wall shall be waterproofed according to Article 503.18 of the Standard Specifications.

DESIGN STRESSES

FIELD UNITS

f'c = 3,500 psi
fy = 60,000 psi (Reinforcement)

DESIGN SPECIFICATIONS

2002 AASHTO Standard Specifications
for Highway Bridges

**GENERAL DETAILS & BILL OF MATERIAL
STRUCTURE NO. 099-W027**

DESIGNED	PMH
CHECKED	MJL
DRAWN	PMH
CHECKED	BB



McDonough Associates Inc.
Engineers / Architects
130 East Randolph Street
Chicago, Illinois 60601
(312) 946-8600

SHEET NO. RW2-6 SHEETS RW2-31	F.A.I. RTE.	SECTION	COUNTY	TOTAL SHEETS	SHEET NO.
	55	(99-1&2) R-6	WILL	756	470
FED. ROAD DIST. NO.			ILLINOIS	FED. AID PROJECT	
CONTRACT NO. 60F12					

STATE OF ILLINOIS
DEPARTMENT OF TRANSPORTATION

Start Retaining Wall
Sta. 3044+66.66

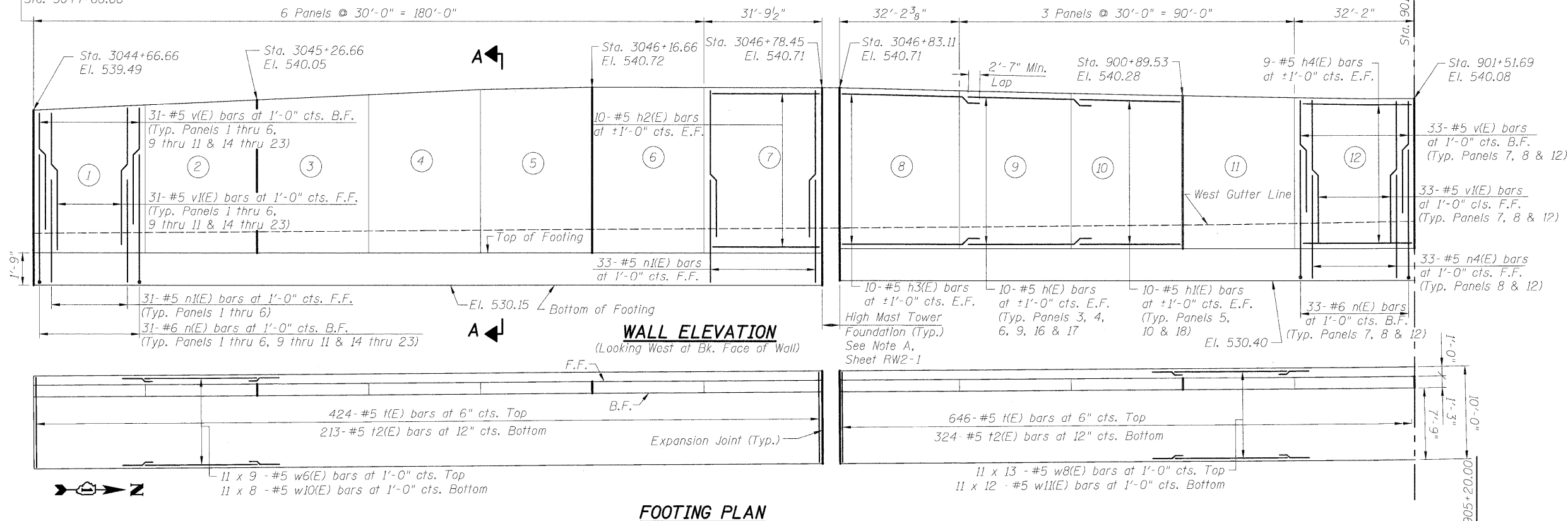

FOOTING PLAN

CONSTRUCTION JOINT ELEVATIONS

Constr. Joint Btwn. Panels	Station	Top Wall Elev.	Bot. Ftg. Elev.
1-2	3044+96.66	539.77	530.15
3-4	3045+56.66	540.32	530.15
4-5	3045+86.66	540.60	530.15
6-7	3046+46.66	540.71	530.15
8-9	900+29.54	540.55	530.40
9-10	900+59.53	540.41	530.40
11-12	901+19.53	540.17	530.40
13-14	901+70.00	540.12	530.40
14-15	902+00.00	540.21	530.40
16-17	902+60.00	540.39	530.40
17-18	902+90.00	540.48	530.40
19-20	903+50.00	540.66	531.23
20-21	903+80.00	540.75	531.23
22-23	904+40.00	540.93	531.23
23-24	904+70.00	541.02	531.23
25-26	905+20.00	541.17	530.85

NOTES:

- For Bar List & Detail 1 see Sheet RW2-19.
- For Typical Details see Sheet RW2-14.
- For Sections A-A and B-B see Sheet RW2-16.
- Bars indicated thus 19 x 7 - #5 etc. indicates 19 lines of bars with 7 lengths per line.

LEGEND:

F.F. = Front Face of Wall
B.F. = Back Face of Wall
E.F. = Each Face of Wall

① = Panel No.

MINIMUM BAR LAP

Top bars #5 bar = 2'-11"
Other bars #5 bar = 2'-7"

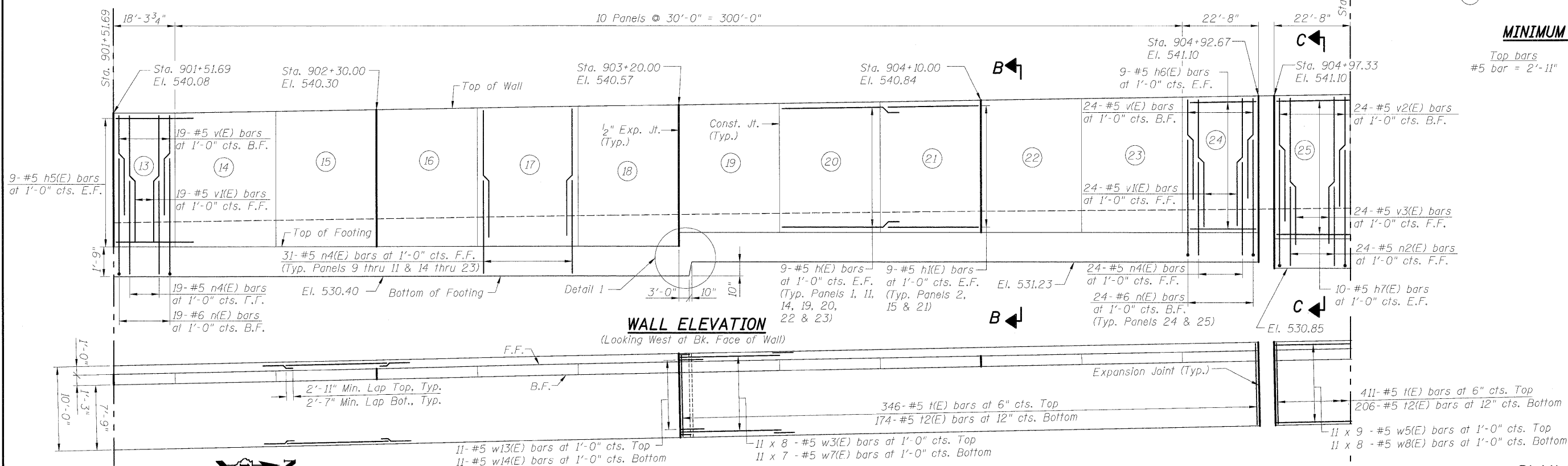

FOOTING PLAN

PLAN & ELEVATION - 1
STRUCTURE NO. 099-W027

DESIGNED	PMH
CHECKED	MJL
DRAWN	PMH
CHECKED	MJL



McDonough Associates Inc.
Engineers / Architects
130 East Randolph Street
Chicago, Illinois 60601
(312) 946-8600

SHEET NO. RW2-7 SHEETS RW2-31	F.A.I. RTE.	SECTION	COUNTY	TOTAL SHEETS	SHEET NO.
	55	(99-1&2) R-6	WILL	756	471
FED. ROAD DIST. NO.			ILLINOIS FED. AID PROJECT		
CONTRACT NO. 60F12					

STATE OF ILLINOIS
DEPARTMENT OF TRANSPORTATION

CONSTRUCTION JOINT ELEVATIONS

Constr. Joint Blwn. Panels	Station	Top Wall Elev.	Bot. Ftg. Elev.
25-26	905+20.00	541.17	530.85
27-28	905+80.00	541.35	530.85
28-29	906+10.00	541.44	530.85
30-31	906+70.00	541.62	530.85
32-33	907+30.00	541.80	530.40
34-35	907+90.00	541.98	530.40
35-36	908+20.00	542.07	530.40
37-38	908+80.00	542.25	530.40
38-39	909+10.00	542.34	530.40
40-41	909+70.00	542.52	530.40
42-43	910+20.00	542.67	530.20
43-44	910+50.00	542.76	530.20
45-46	911+10.00	542.94	530.20
46-47	911+40.00	543.03	530.20
48-49	912+00.00	543.21	530.20
49-50	912+30.00	543.30	530.20

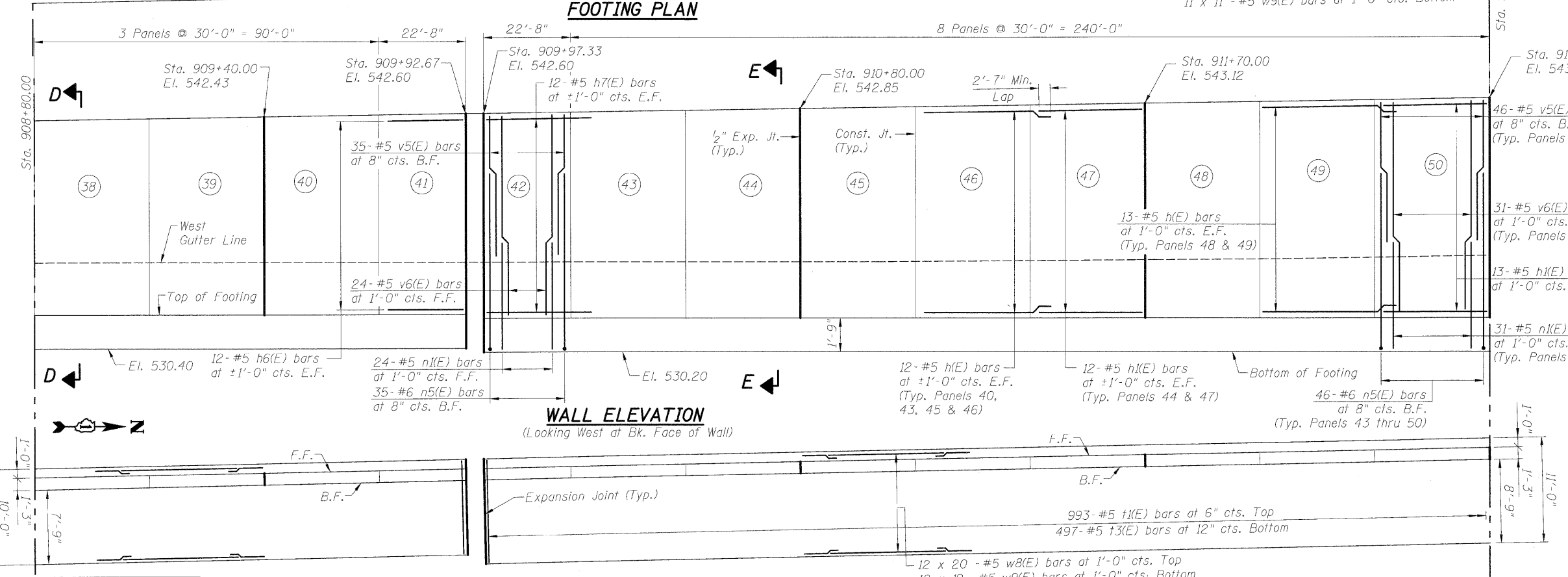
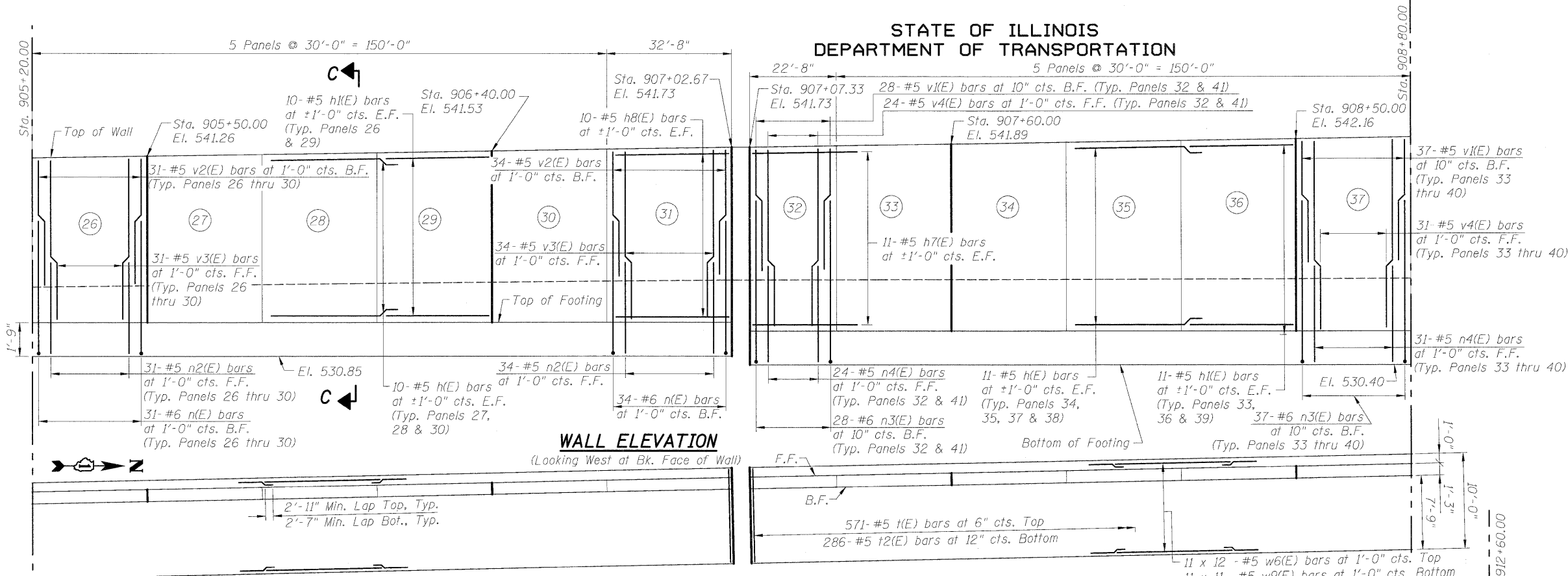

NOTES:

- For Bar List see Sheet RW2-19.
- For Typical Details see Sheet RW2-14.
- For Sections C-C, D-D and E-E see Sheets RW2-16 & RW2-17.
- Bars indicated thus 19 x 7 - #5 etc. indicates 19 lines of bars with 7 lengths per line.

LEGEND:

- F.F. = Front Face of Wall
- B.F. = Back Face of Wall
- E.F. = Each Face of Wall
- (i) = Panel No.

MINIMUM BAR LAP

Top bars #5 bar = 2'-11" Other bars #5 bar = 2'-7"

PLAN & ELEVATION - 2
STRUCTURE NO. 099-W027

DESIGNED	PMH
CHECKED	MJL
DRAWN	PMH
CHECKED	MJL

McDonough Associates Inc.
Engineers / Architects
130 East Randolph Street
Chicago, Illinois 60601
(312) 946-8600

SHEET NO. RW2-8 SHEETS RW2-31	F.A.I. RTE.	SECTION	COUNTY	TOTAL SHEETS	SHEET NO.
	55	(99-1&2) R-6	WILL	756	472
FED. ROAD DIST. NO.			ILLINOIS FED. AID PROJECT		
CONTRACT NO. 60F12					

STATE OF ILLINOIS
DEPARTMENT OF TRANSPORTATION

CONSTRUCTION JOINT ELEVATIONS

Constr. Joint Btwn. Panels	Station	Top Wall Elev.	Bot. Ftg. Elev.
51-52	912+90.00	543.48	530.20
52-53	913+20.00	543.57	530.20
54-55	913+70.92	543.72	530.20
55-56	914+00.91	543.81	530.20
57-58	914+60.90	543.99	530.20
59-60	915+20.00	544.17	532.20
60-61	915+50.00	544.26	532.20
62-63	916+10.00	544.44	533.95
63-64	916+40.00	544.53	533.95
65-66	917+00.00	544.71	533.95
66-67	917+30.00	544.80	533.95
68-69	917+90.00	544.98	533.95
69-70	918+20.00	545.07	533.95
71-72	918+80.00	545.25	535.62
72-73	919+10.00	545.34	535.62
74-75	919+70.00	545.52	535.62

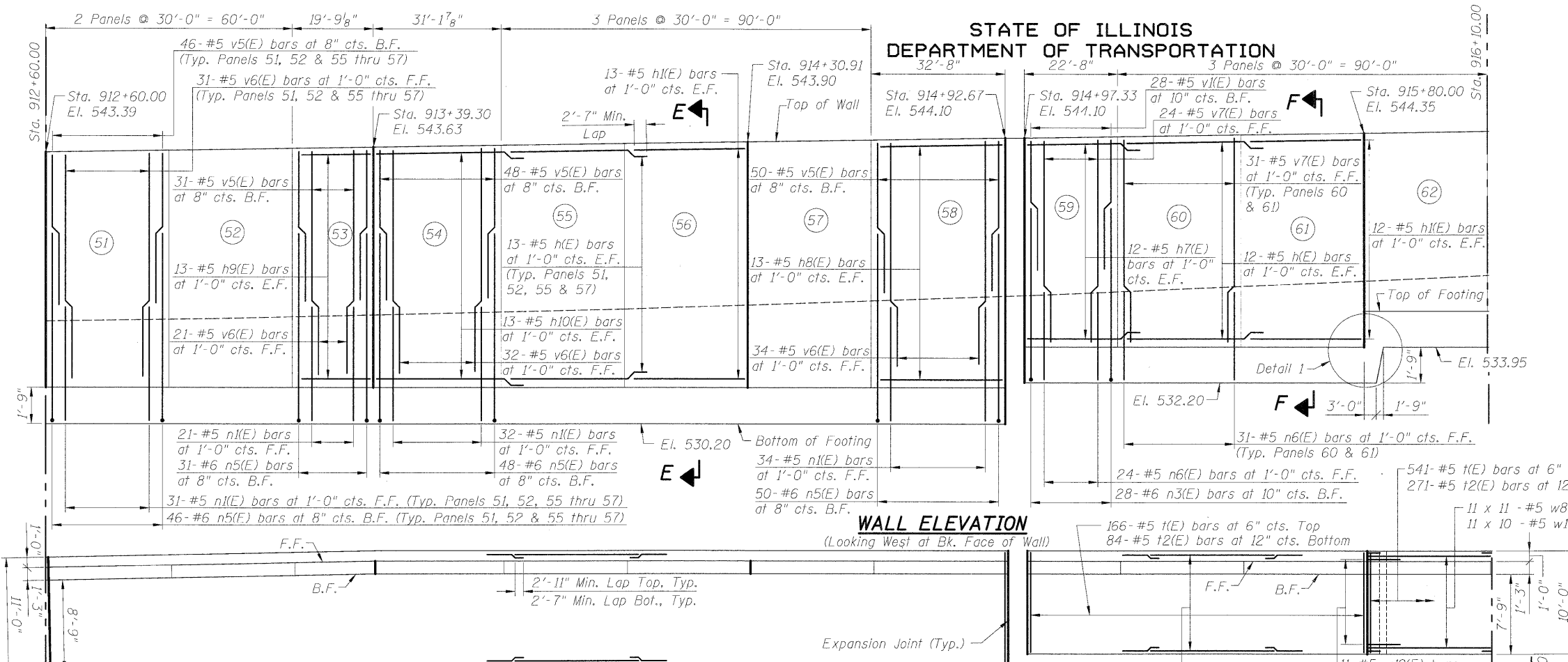

NOTES:

- For Bar List & Detail 1 see Sheet RW2-19.
- For Typical Details see Sheet RW2-14.
- For Sections D-D, E-E and F-F see Sheets RW2-16 & RW2-17.
- Bars indicated thus 19 x 7 - #5 etc. indicates 19 lines of bars with 7 lengths per line.

LEGEND:

- F.F. = Front Face of Wall
- B.F. = Back Face of Wall
- E.F. = Each Face of Wall

① = Panel No.

MINIMUM BAR LAP

- Top bars #5 bar = 2'-11"
- Other bars #5 bar = 2'-7"

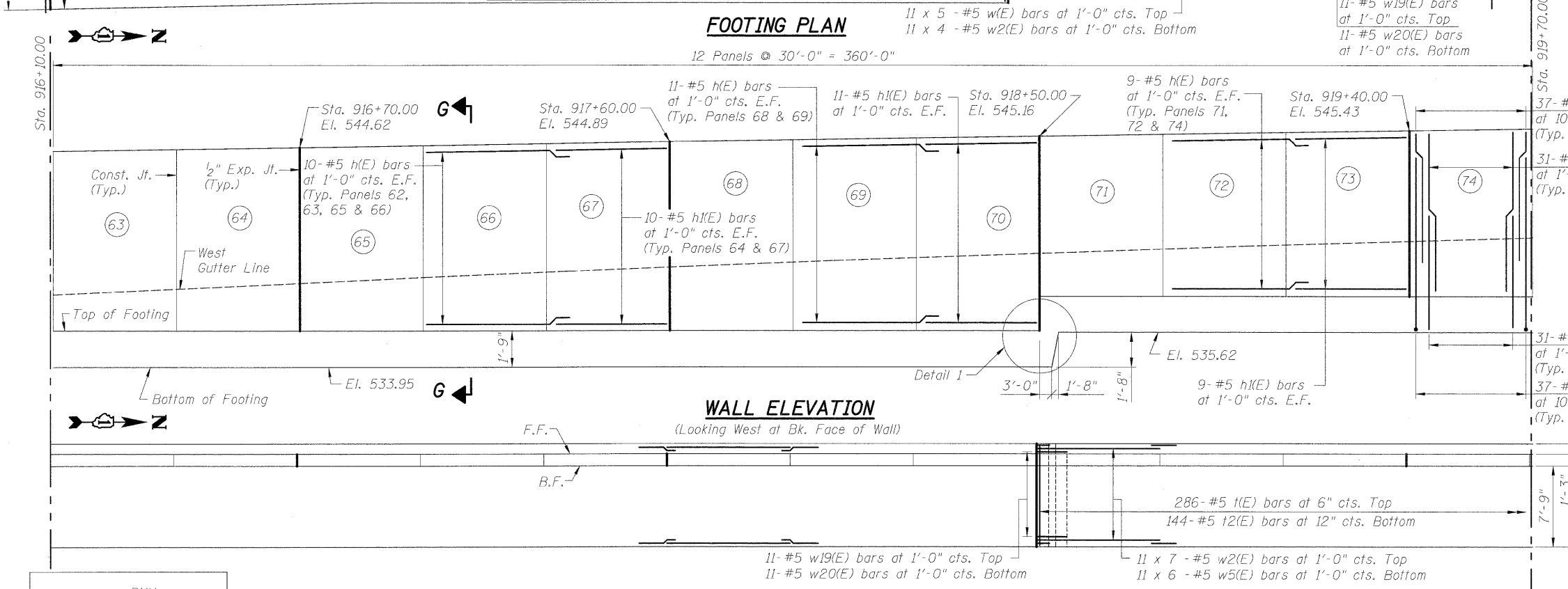

FOOTING PLAN

PLAN & ELEVATION - 3
STRUCTURE NO. 099-W027

DESIGNED	PMH
CHECKED	MJL
DRAWN	PMH
CHECKED	MJL

McDonough Associates Inc.
Engineers / Architects
130 East Randolph Street
Chicago, Illinois 60601
(312) 946-8600

SHEET NO. RW2-9 SHEETS RW2-31	F.A.I. RTE.	SECTION	COUNTY	TOTAL SHEETS	SHEET NO.
	55	(99-1&2) R-6	WILL	756	473
FED. ROAD DIST. NO.			ILLINOIS FED. AID PROJECT		
CONTRACT NO. 60F12					

STATE OF ILLINOIS
DEPARTMENT OF TRANSPORTATION

11 Panels @ 30'-0" = 330'-0"

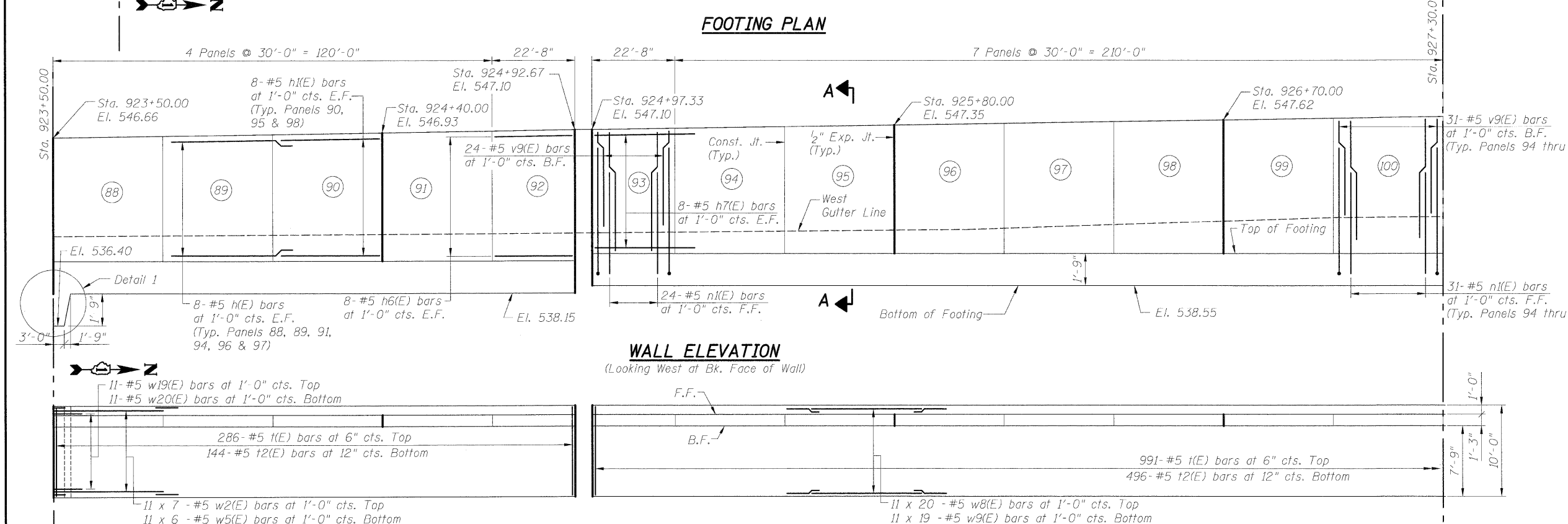
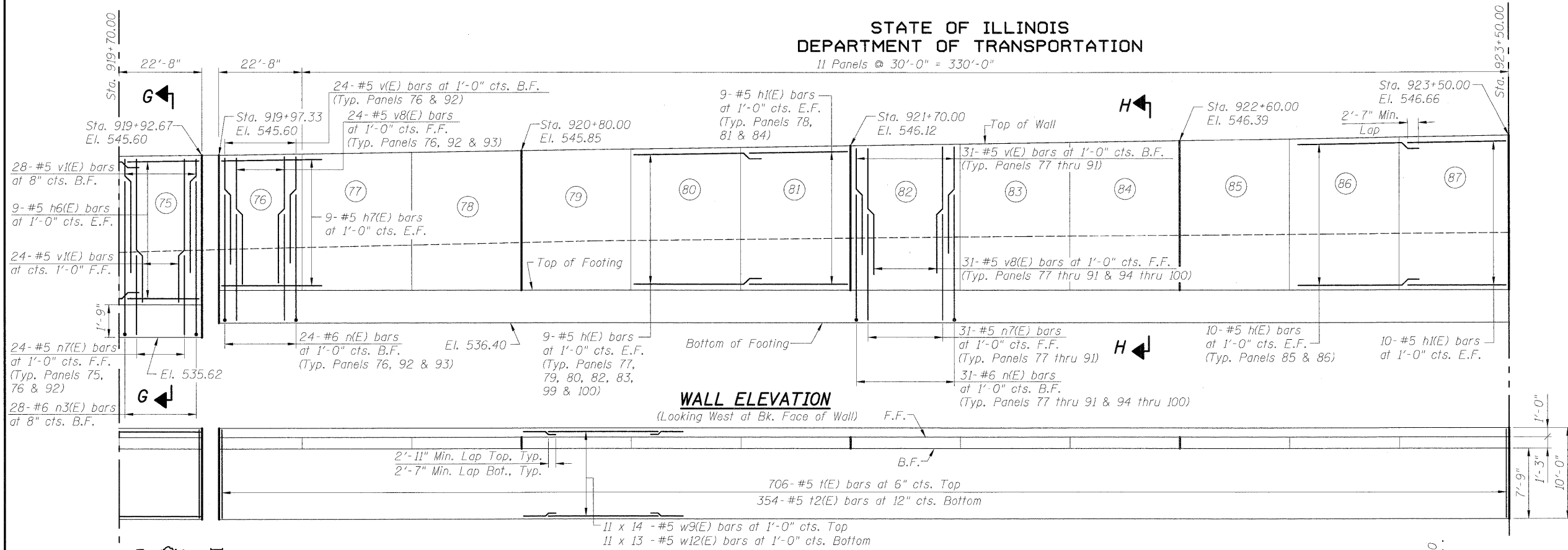

CONSTRUCTION JOINT ELEVATIONS

Constr. Joint Btwn. Panels	Station	Top Wall Elev.	Bot. Ftg. Elev.
74-75	919+70.00	545.52	535.62
76-77	920+20.00	545.67	536.40
77-78	920+50.00	545.76	536.40
79-80	921+10.00	545.94	536.40
80-81	921+40.00	546.03	536.40
82-83	922+00.00	546.21	536.40
83-84	922+30.00	546.30	536.40
85-86	922+90.00	546.48	536.40
86-87	923+20.00	546.57	536.40
88-89	923+80.00	546.75	538.15
89-90	924+10.00	546.84	538.15
91-92	924+70.00	547.02	538.15
93-94	925+20.00	547.17	538.55
94-95	925+50.00	547.26	538.55
96-97	926+10.00	547.44	538.55
97-98	926+40.00	547.53	538.55
99-100	927+00.00	547.71	538.55
100-101	927+30.00	547.80	538.55

- NOTES:**
- For Bar List & Detail 1 see Sheet RW2-19.
 - For Typical Details see Sheet RW2-14.
 - For Sections A-A, G-G and H-H see Sheets RW2-16 thru RW2-18.
 - Bars indicated thus 19 x 7 - #5 etc. indicates 19 lines of bars with 7 lengths per line.

LEGEND:

- F.F. = Front Face of Wall
- B.F. = Back Face of Wall
- E.F. = Each Face of Wall
- (i) = Panel No.

MINIMUM BAR LAP

Top bars	Other bars
#5 bar = 2'-11"	#5 bar = 2'-7"

**PLAN & ELEVATION - 4
STRUCTURE NO. 099-W027**

DESIGNED	PMH
CHECKED	MJL
DRAWN	PMH
CHECKED	MJL

McDonough Associates Inc.
Engineers / Architects
130 East Randolph Street
Chicago, Illinois 60601
(312) 946-8600

SHEET NO. RW2-10 SHEETS RW2-31	F.A.I. RTE.	SECTION	COUNTY	TOTAL SHEETS	SHEET NO.
	55	(99-1&2) R-6	WILL	756	474
FED. ROAD DIST. NO.			ILLINOIS FED. AID PROJECT		
CONTRACT NO. 60F12					

STATE OF ILLINOIS
DEPARTMENT OF TRANSPORTATION

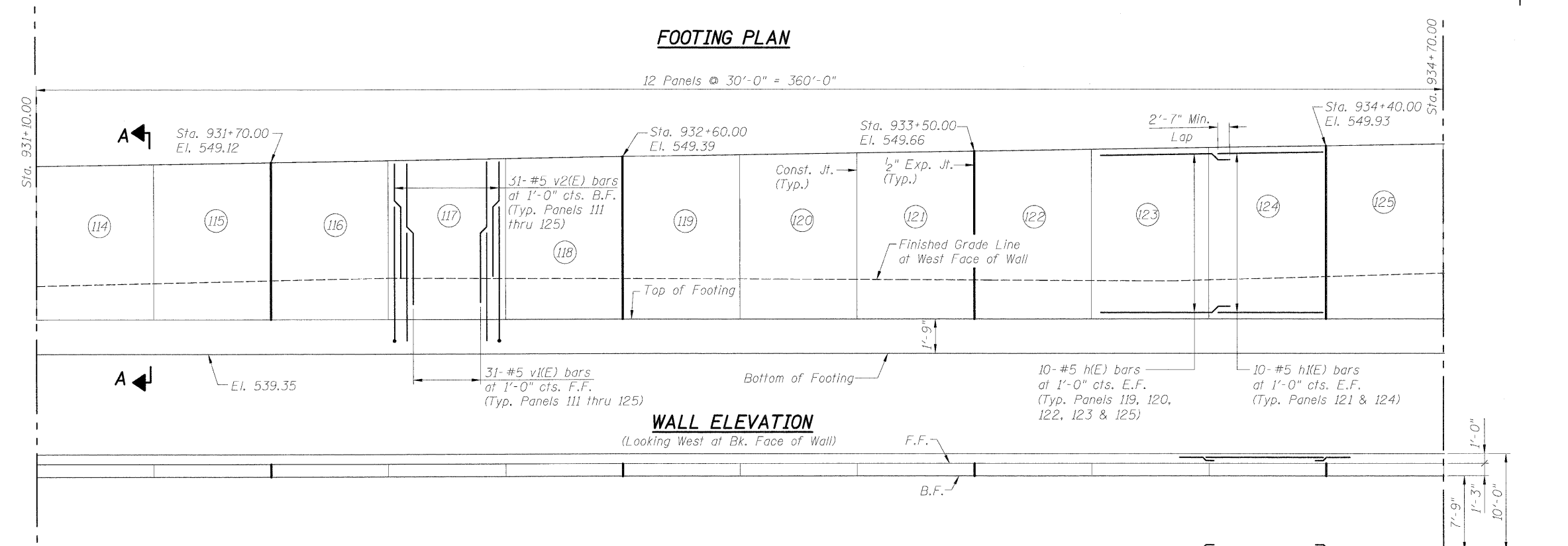
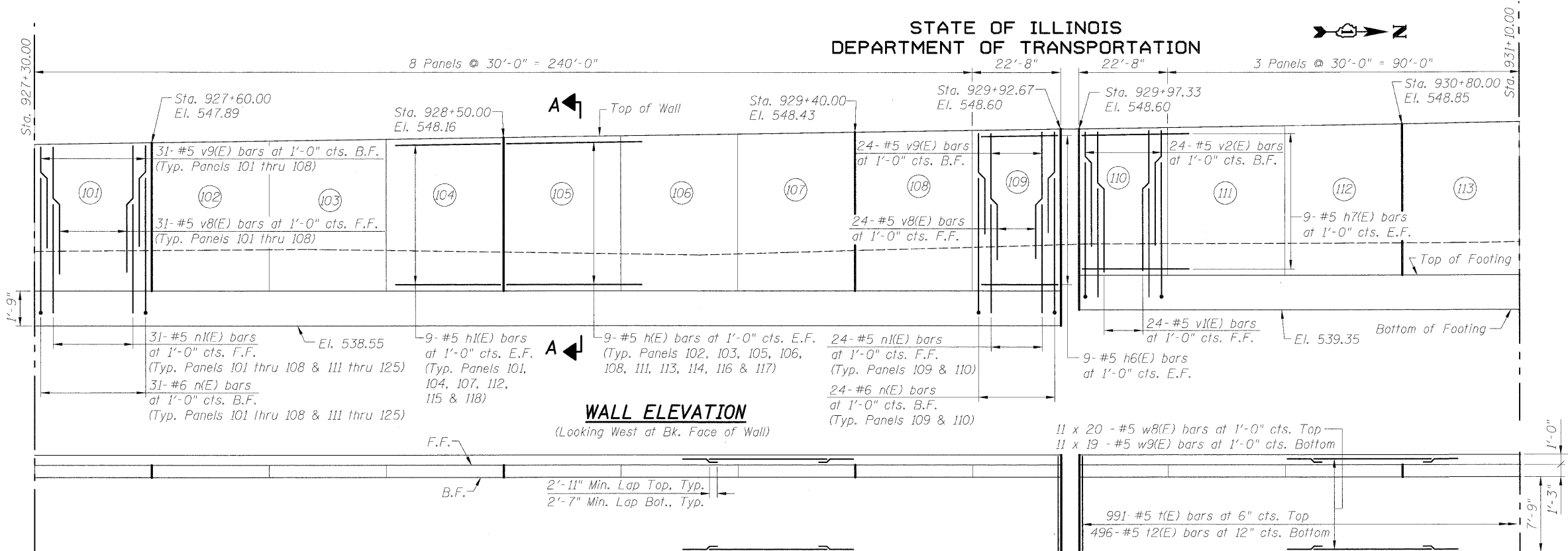

CONSTRUCTION JOINT ELEVATIONS

Constr. Joint Btwn. Panels	Station	Top Wall Elev.	Bot. Ftg. Elev.
100-101	927+30.00	547.80	538.55
102-103	927+90.00	547.98	538.55
103-104	928+20.00	548.07	538.55
105-106	928+80.00	548.25	538.55
106-107	929+10.00	548.34	538.55
108-109	929+70.00	548.52	538.55
110-111	930+20.00	548.67	539.35
111-112	930+50.00	548.76	539.35
113-114	931+10.00	548.94	539.35
114-115	931+40.00	549.03	539.35
116-117	932+00.00	549.21	539.35
117-118	932+30.00	549.30	539.35
119-120	932+90.00	549.48	539.35
120-121	933+20.00	549.57	539.35
122-123	933+80.00	549.75	539.35
123-124	934+10.00	549.84	539.35
125-126	934+70.00	550.02	539.35

NOTES:

- For Bar List see Sheet RW2-19.
- For Typical Details see Sheets RW2-14 & RW2-15.
- For Section A-A see Sheet RW2-16.
- Bars indicated thus 19 x 7 - #5 etc. indicates 19 lines of bars with 7 lengths per line.

LEGEND:

- F.F. = Front Face of Wall
- B.F. = Back Face of Wall
- E.F. = Each Face of Wall
- (1) = Panel No.

MINIMUM BAR LAP

- Top bars: #5 bar = 2'-11"
- Other bars: #5 bar = 2'-7"

DESIGNED	PMH
CHECKED	MJL
DRAWN	PMH
CHECKED	MJL

FOOTING PLAN

PLAN & ELEVATION - 5
STRUCTURE NO. 099-W027



McDonough Associates Inc.
Engineers / Architects
130 East Randolph Street
Chicago, Illinois 60601
(312) 946-8600

SHEET NO. RW2-11 SHEETS RW2-31	F.A.I. RTE.	SECTION	COUNTY	TOTAL SHEETS	SHEET NO.
	55	(99-1&2) R-6	WILL	756	475
FED. ROAD DIST. NO.			ILLINOIS	FED. AID PROJECT	
CONTRACT NO. 60F12					

STATE OF ILLINOIS
DEPARTMENT OF TRANSPORTATION

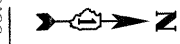

CONSTRUCTION JOINT ELEVATIONS

Constr. Joint Btwn. Panels	Station	Top Wall Elev.	Bot. Ftg. Elev.
150-151	942+05.00	558.54	546.70
151-152	942+35.00	558.68	546.70
153-154	942+95.00	558.77	546.70
154-155	943+25.00	558.73	546.70
156-157	943+85.00	558.54	548.12
157-158	944+15.00	558.45	548.12
159-160	944+75.00	558.26	547.82
160-161	945+05.00	558.17	547.82
162-163	945+65.00	557.98	546.15
163-164	945+95.00	557.89	546.15
165-166	946+55.00	557.70	546.15
166-167	946+85.00	557.61	546.15
168-169	947+45.00	557.42	546.15
169-170	947+75.00	557.33	546.15
171-172	948+35.00	557.14	546.15
172-173	948+65.00	557.05	546.65

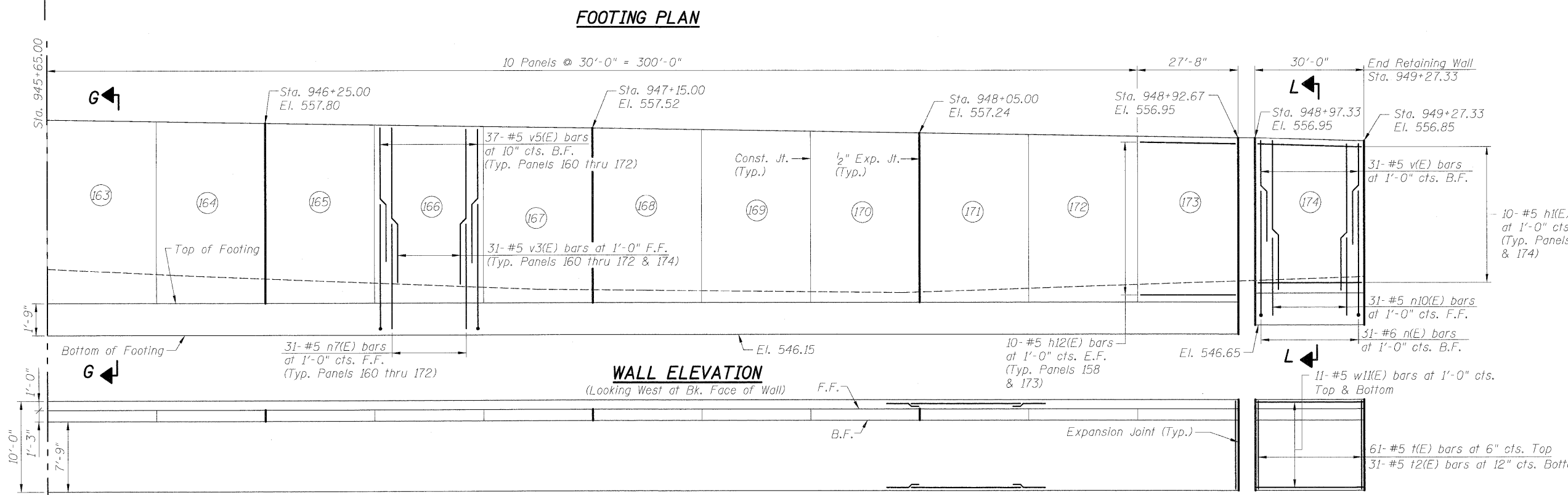
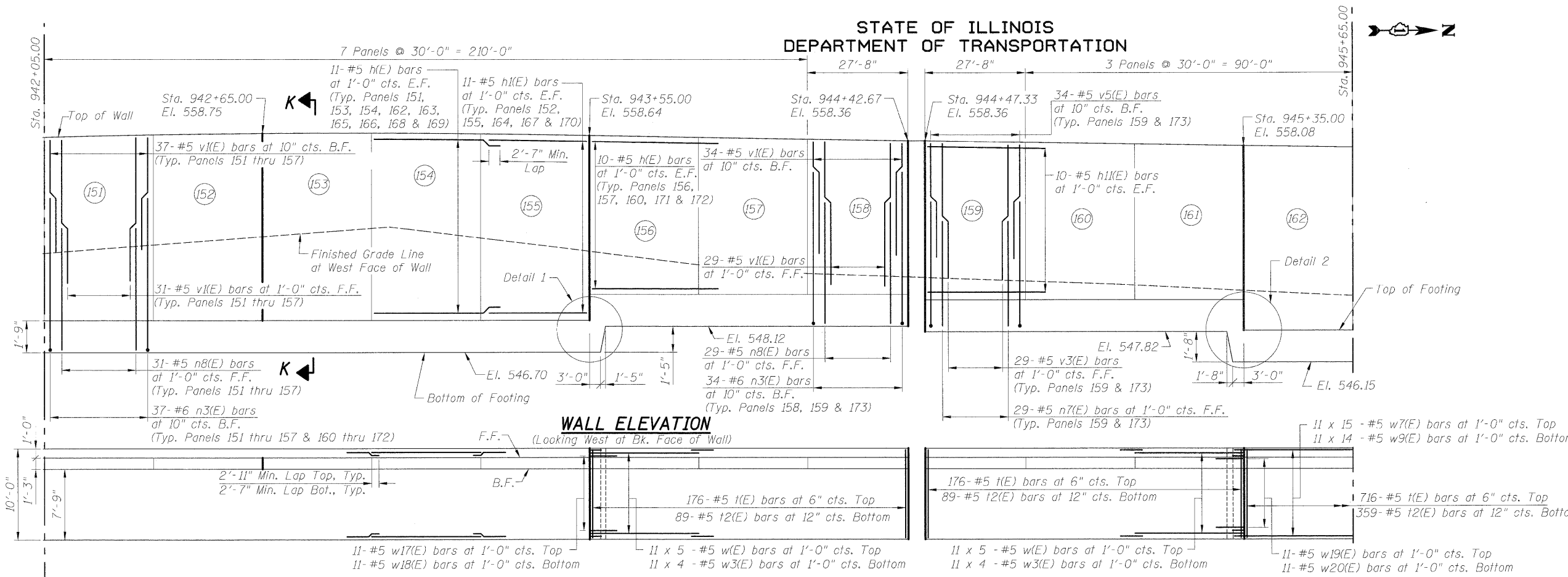

NOTES:

- For Bar List & Details 1 & 2 see Sheet RW2-19.
- For Typical Details see Sheet RW2-15.
- For Sections G-G, K-K and L-L see Sheets RW2-17 & RW2-18.
- Bars indicated thus 19 x 7 - #5 etc. indicates 19 lines of bars with 7 lengths per line.

LEGEND:

- F.F. = Front Face of Wall
- B.F. = Back Face of Wall
- E.F. = Each Face of Wall
- (1) = Panel No.

MINIMUM BAR LAP

- Top bars #5 bar = 2'-11"
- Other bars #5 bar = 2'-7"

DESIGNED	PMH
CHECKED	MJL
DRAWN	PMH
CHECKED	MJL

McDonough Associates Inc.
Engineers / Architects
130 East Randolph Street
Chicago, Illinois 60601
(312) 946-8600

SHEET NO. RW2-13 SHEETS RW2-31	F.A.I. RTE.	SECTION	COUNTY	TOTAL SHEETS	SHEET NO.
	55	(99-1&2) R-6	WILL	756	477
FED. ROAD DIST. NO.			ILLINOIS FED. AID PROJECT		

PLAN & ELEVATION - 7
STRUCTURE NO. 099-W027

STATE OF ILLINOIS
DEPARTMENT OF TRANSPORTATION

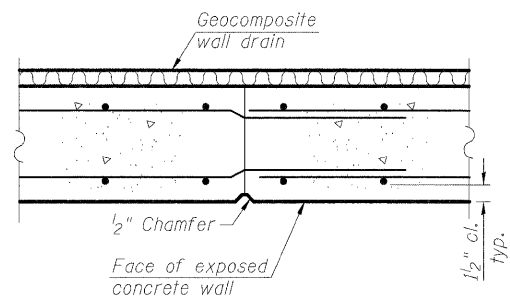

CONSTRUCTION JOINT DETAIL

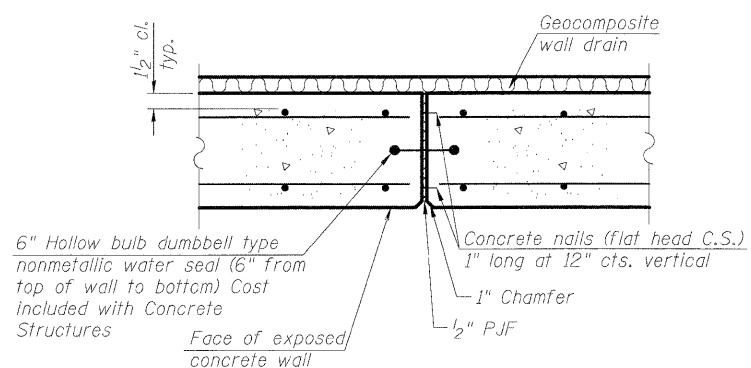

EXPANSION JOINT DETAIL

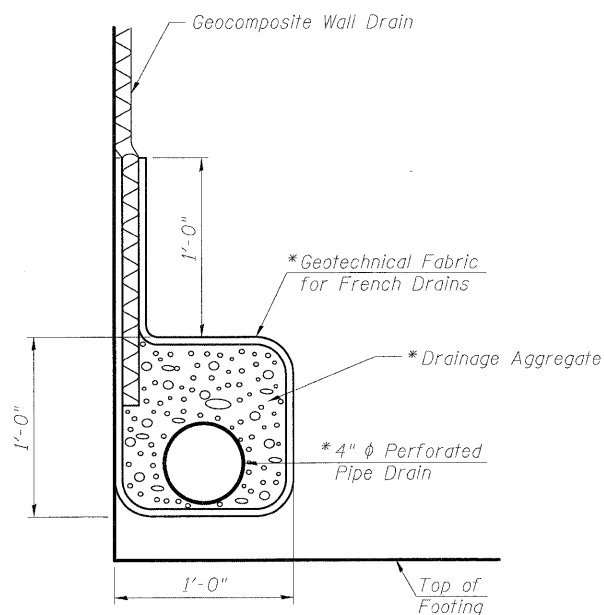

PIPE UNDERDRAIN DETAIL

* Included in the cost of "Pipe Underdrains for Structures 4".

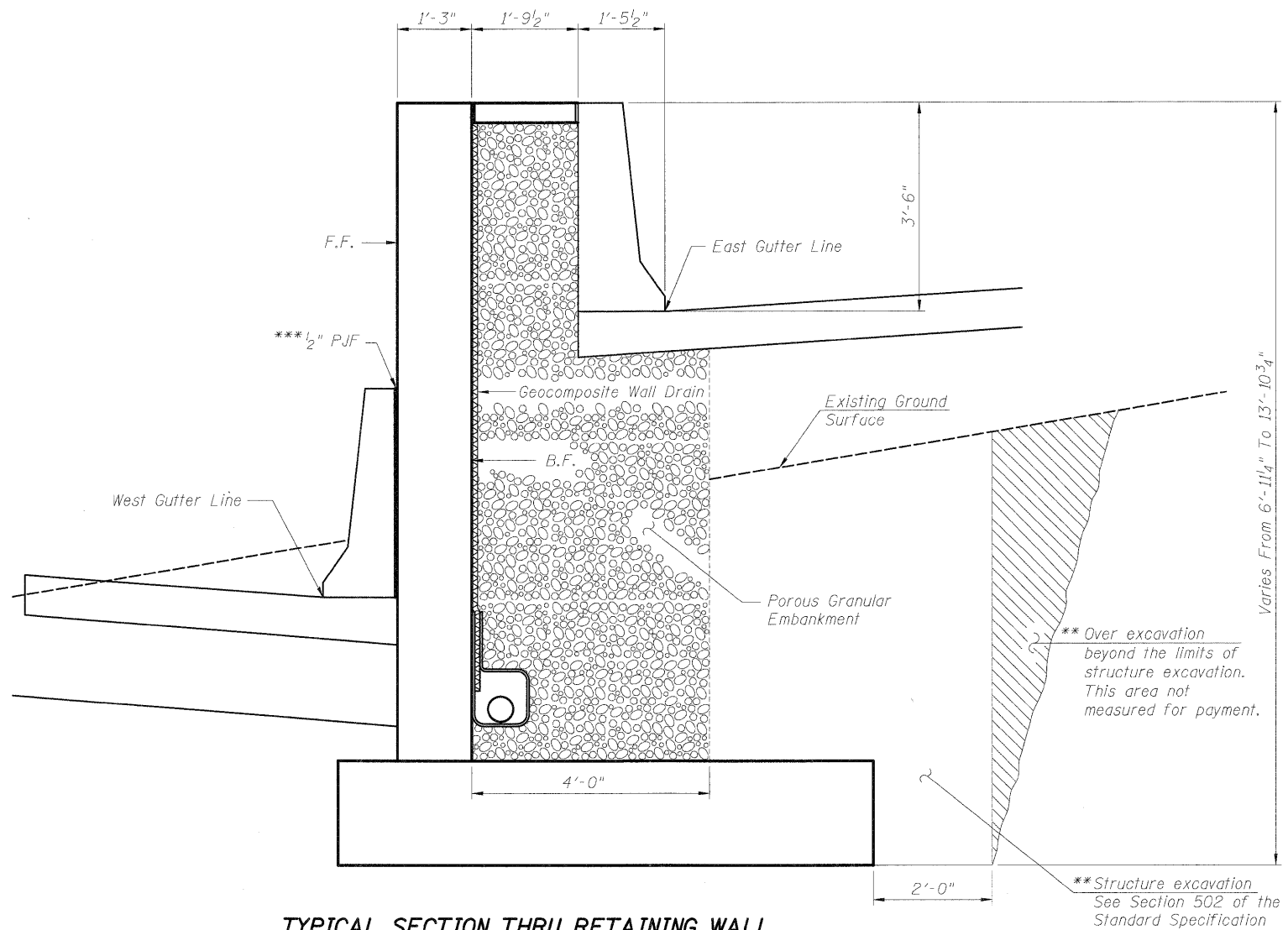

TYPICAL SECTION THRU RETAINING WALL

(Ramp B Sta. 3044+66.66 to Sta. 3046+85.77)
(Arsenal Rd. Sta. 900+00.00 to Sta. 934+47.18)

*** Included in the cost of Barrier Wall

LEGEND:

F.F. = Front Face of Wall
B.F. = Back Face of Wall
E.F. = Each Face of Wall

** Backfill remainder of structure excavation and over excavation with same material specified for roadway embankment.

DESIGNED	PMH
CHECKED	MJL
DRAWN	PMH
CHECKED	BB



McDonough Associates Inc.
Engineers / Architects
130 East Randolph Street
Chicago, Illinois 60601
(312) 946-8600

SHEET NO. RW2-14 SHEETS RW2-31	F.A.I. RTE.	SECTION	COUNTY	TOTAL SHEETS	SHEET NO.
	55	(99-1&2) R-6	WILL	756	478
FED. ROAD DIST. NO.			ILLINOIS FED. AID PROJECT		
CONTRACT NO. 60F12					

**SECTION AND DETAILS
STRUCTURE NO. 099-W027**

STATE OF ILLINOIS
DEPARTMENT OF TRANSPORTATION

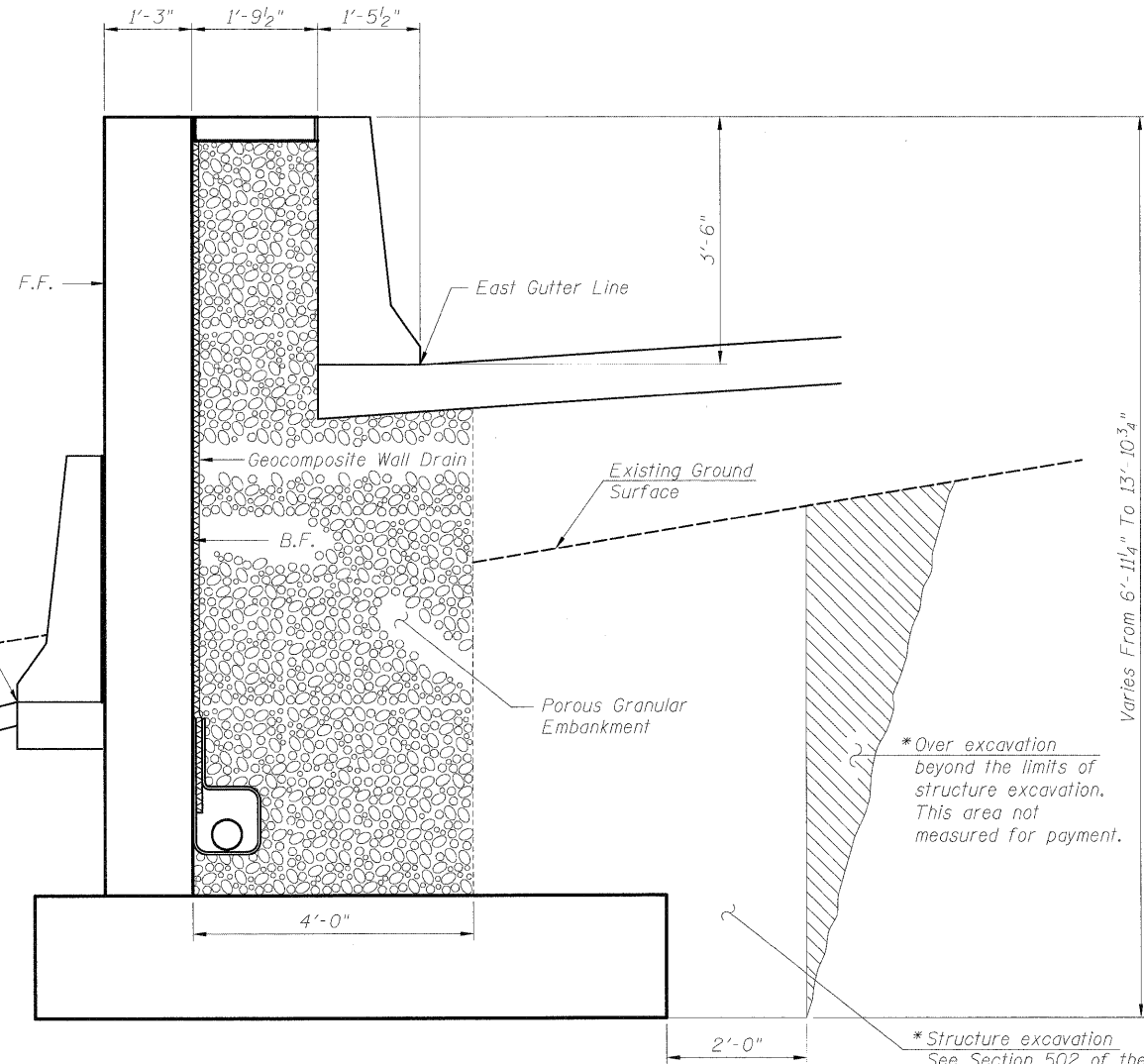

TYPICAL SECTION THRU RETAINING WALL

(Arsenal Rd. Sta. 934+47.18 to Sta. 934+92.67)

* Backfill remainder of structure excavation and over excavation with same material specified for roadway embankment.

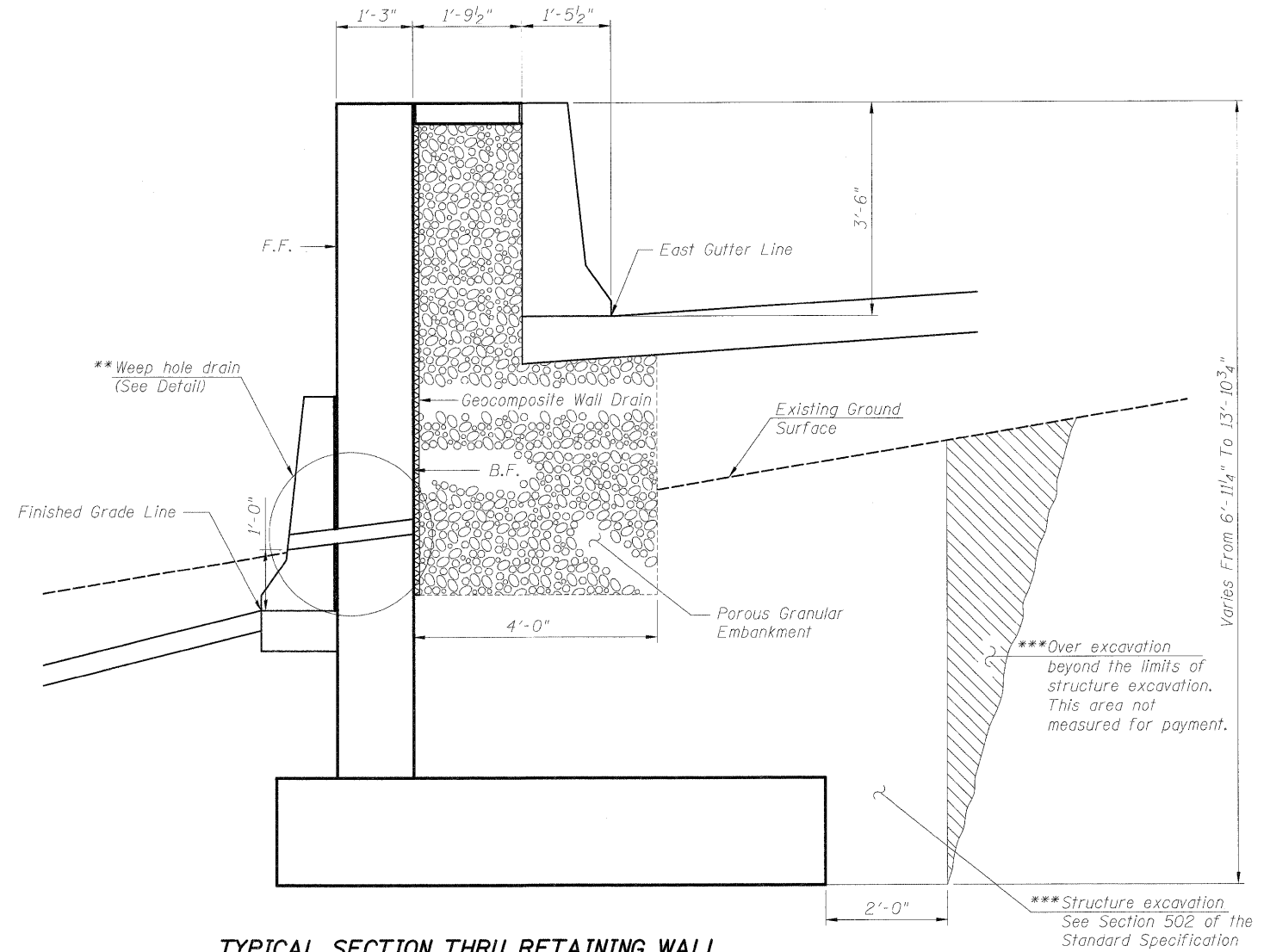

TYPICAL SECTION THRU RETAINING WALL

(Arsenal Rd. Sta. 934+97.33 to Sta. 949+27.33)

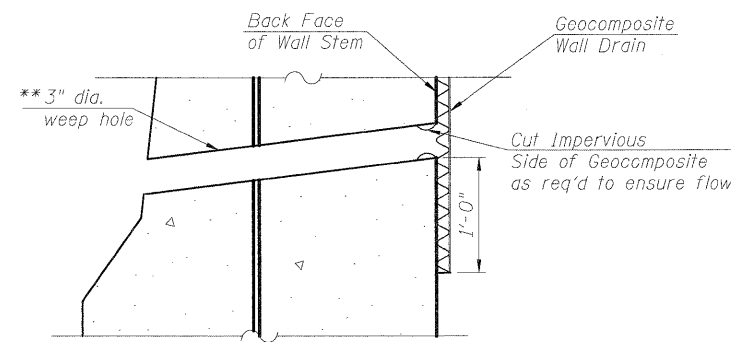

WEEP HOLE DRAIN DETAIL

** Weep hole spacing shall be at ±8'-0" horizontally. Weep holes included in cost of "Concrete Structures."

*** Backfill remainder of structure excavation and over excavation with same material specified for roadway embankment.

LEGEND:

F.F. = Front Face of Wall
B.F. = Back Face of Wall
E.F. = Each Face of Wall

**SECTION AND DETAILS
STRUCTURE NO. 099-W027**

DESIGNED	PMH
CHECKED	MJL
DRAWN	PMH
CHECKED	BB



McDonough Associates Inc.
Engineers / Architects
130 East Randolph Street
Chicago, Illinois 60601
(312) 946-8600

SHEET NO. RW2-15 SHEETS RW2-31	F.A.I. RTE.	SECTION	COUNTY	TOTAL SHEETS	SHEET NO.
	55	(99-1&2) R-6	WILL	756	479
FED. ROAD DIST. NO.			ILLINOIS FED. AID PROJECT		
CONTRACT NO. 60F12					

STATE OF ILLINOIS
DEPARTMENT OF TRANSPORTATION

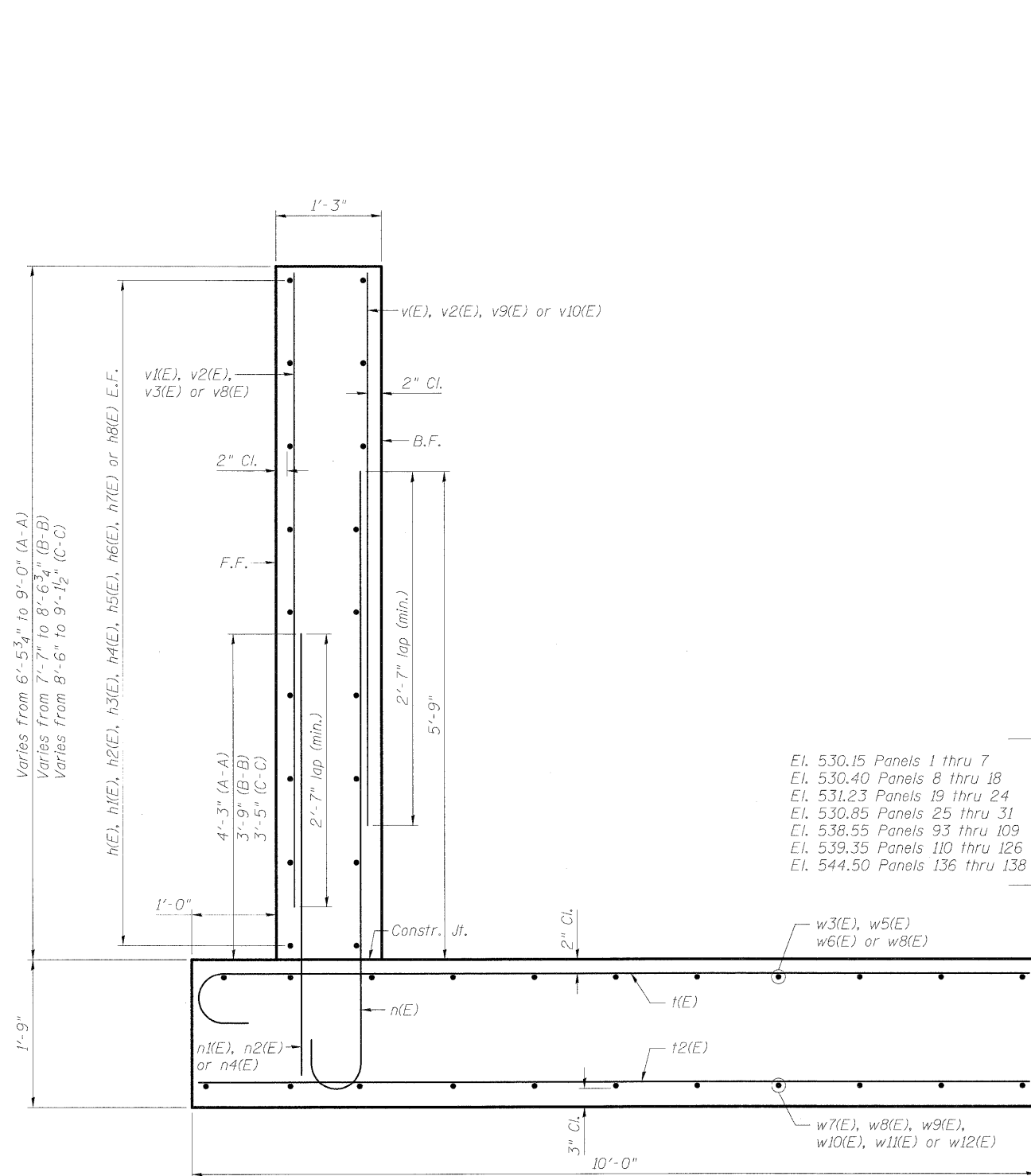

SECTION A-A, SECTION B-B & SECTION C-C
PANELS 1 THRU 7, 93 THRU 126 & 136 THRU 138 (A-A)
PANELS 8 THRU 24 (B-B)
PANELS 25 THRU 31 (C-C)

Max. Soil Pressure = 2.47 ksf

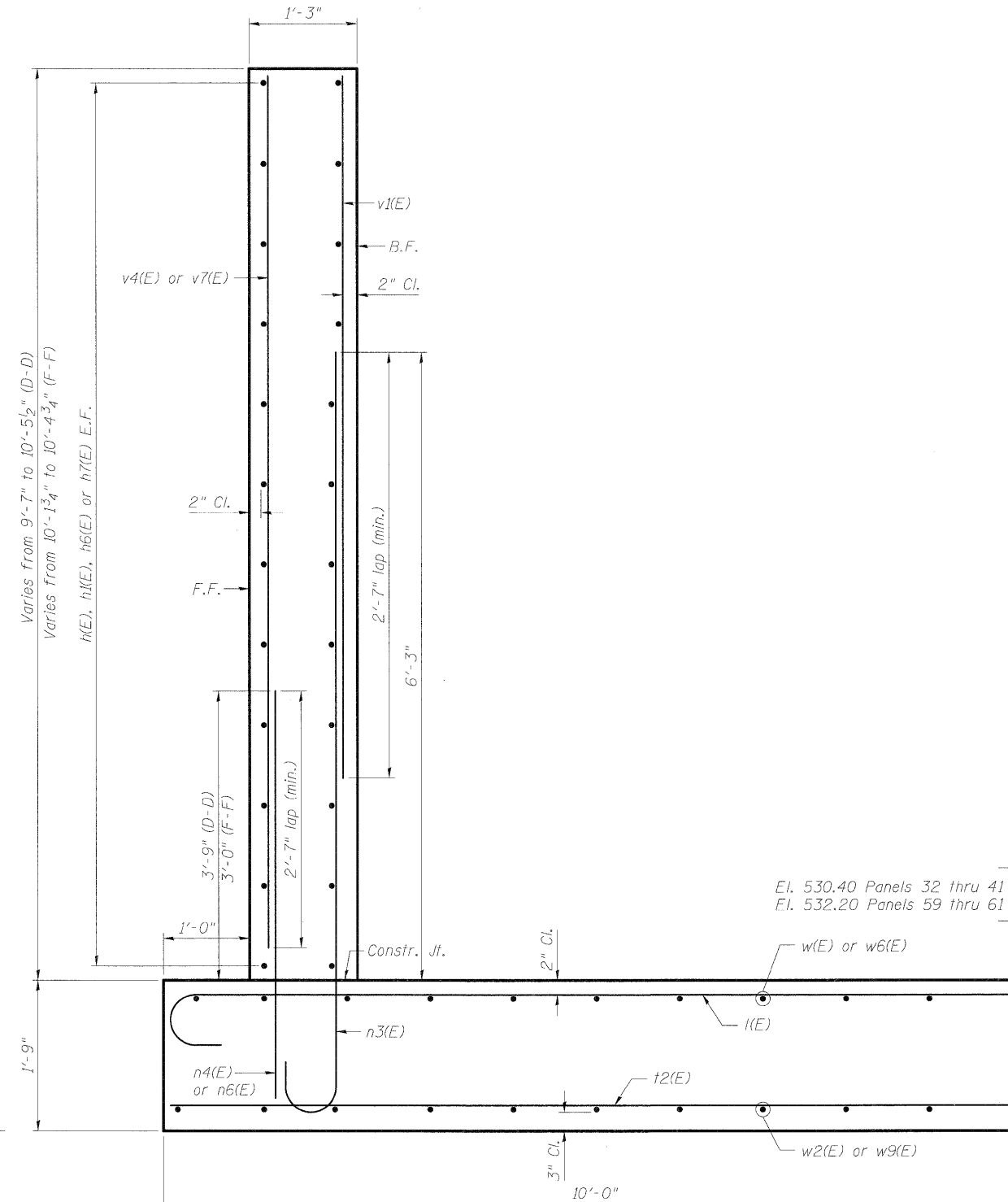

SECTION D-D & SECTION F-F
PANELS 32 THRU 41 (D-D)
PANELS 59 THRU 61 (F-F)

Max. Soil Pressure = 2.95 ksf

- NOTES:**
1. For Bill of Material see Sheet RW2-19.
 2. Reinforcement Bars designated (E) shall be Epoxy Coated.

- LEGEND:**
- F.F. = Front Face of Wall
 - B.F. = Back Face of Wall
 - E.F. = Each Face of Wall

SECTION AND DETAILS
STRUCTURE NO. 099-W027

DESIGNED	PMH
CHECKED	MJL
DRAWN	PMH
CHECKED	MJL

McDonough Associates Inc.
 Engineers / Architects
 130 East Randolph Street
 Chicago, Illinois 60601
 (312) 946-8600

SHEET NO. RW2-16 SHEETS RW2-31	F.A.I. RTE.	SECTION	COUNTY	TOTAL SHEETS	SHEET NO.
	55	(99-1&2) R-6	WILL	756	480
FED. ROAD DIST. NO.			ILLINOIS FED. AID PROJECT		
CONTRACT NO. 60F12					

STATE OF ILLINOIS
DEPARTMENT OF TRANSPORTATION

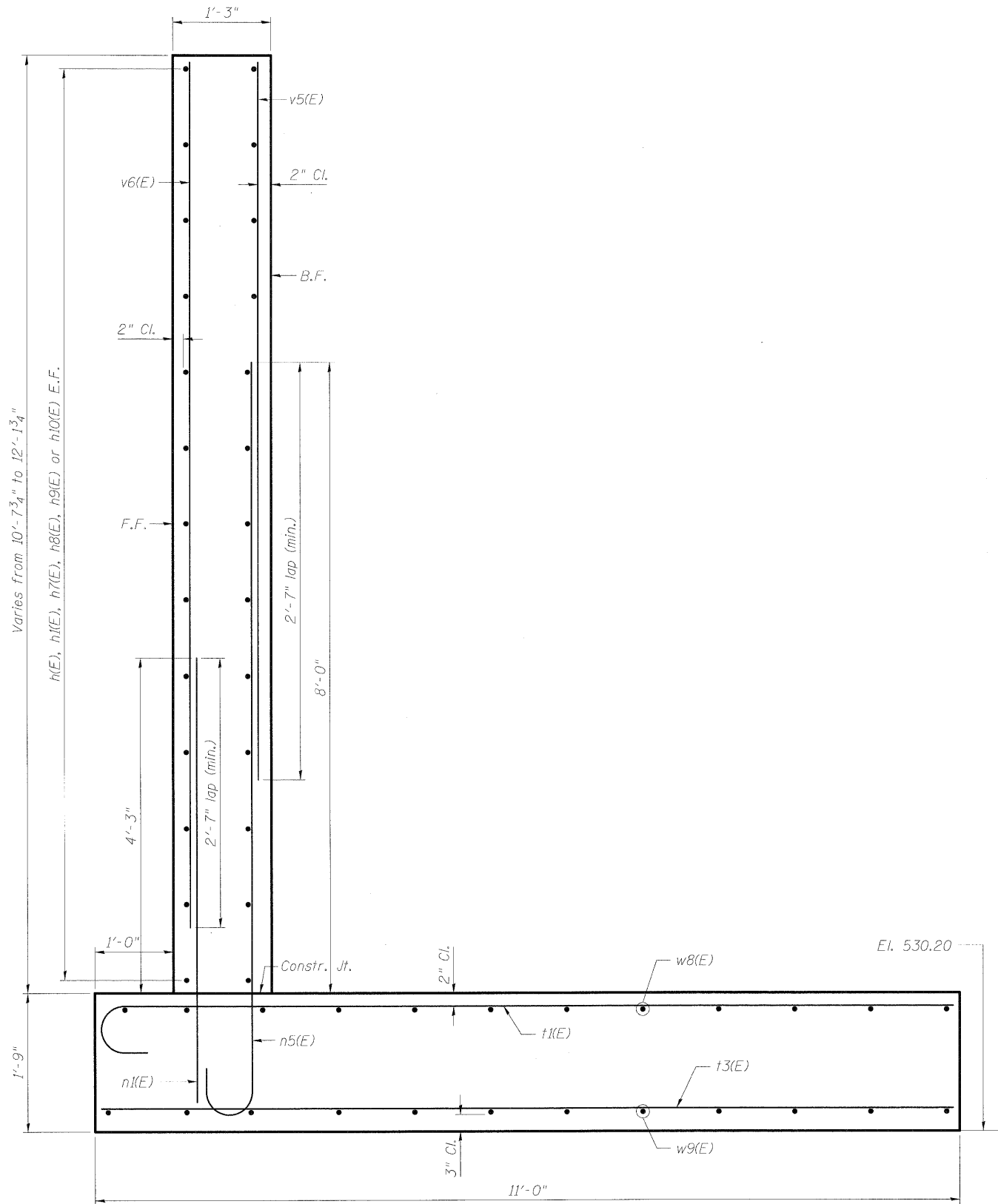

SECTION E-E
PANELS 42 THRU 58

Max. Soil Pressure = 3.12 ksf

DESIGNED	PMH
CHECKED	MJL
DRAWN	PMH
CHECKED	MJL

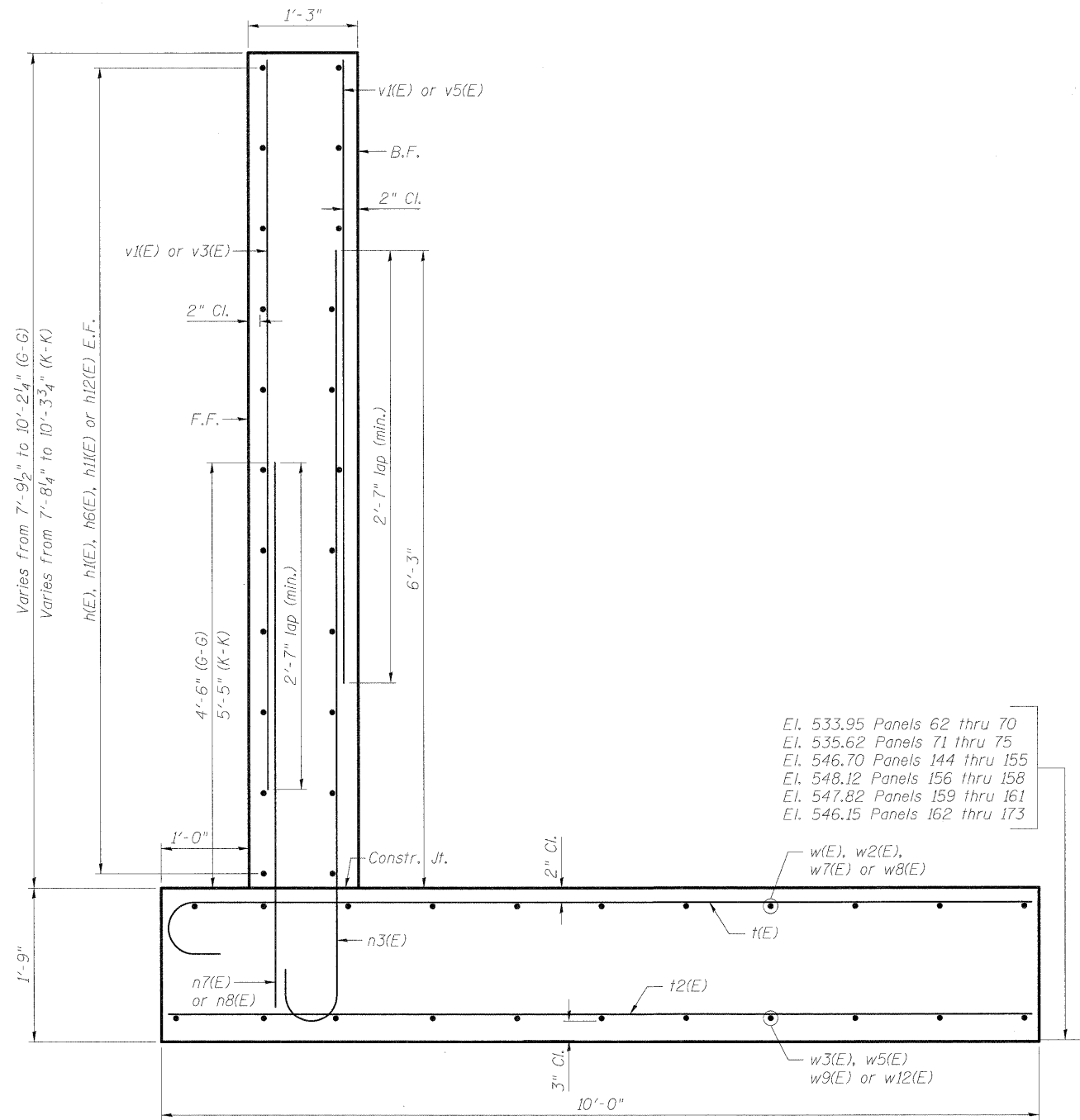

SECTION G-G & SECTION K-K
PANELS 62 THRU 75 & 159 THRU 173 (G-G)
PANELS 144 THRU 158 (K-K)

Max. Soil Pressure = 2.95 ksf

El. 533.95 Panels 62 thru 70
El. 535.62 Panels 71 thru 75
El. 546.70 Panels 144 thru 155
El. 548.12 Panels 156 thru 158
El. 547.82 Panels 159 thru 161
El. 546.15 Panels 162 thru 173

NOTES:

1. For Bill of Material see Sheet RW2-19.
2. Reinforcement Bars designated (E) shall be Epoxy Coated.

LEGEND:

F.F. = Front Face of Wall
B.F. = Back Face of Wall
E.F. = Each Face of Wall

SECTION AND DETAILS
STRUCTURE NO. 099-W027



McDonough Associates Inc.
Engineers / Architects
130 East Randolph Street
Chicago, Illinois 60601
(312) 946-8600

SHEET NO. RW2-17 SHEETS RW2-31	F.A.I. RTE.	SECTION	COUNTY	TOTAL SHEETS	SHEET NO.
	55	(99-1&2) R-6	WILL	756	481
FED. ROAD DIST. NO.			ILLINOIS	FED. AID PROJECT	
CONTRACT NO. 60F12					

STATE OF ILLINOIS
DEPARTMENT OF TRANSPORTATION

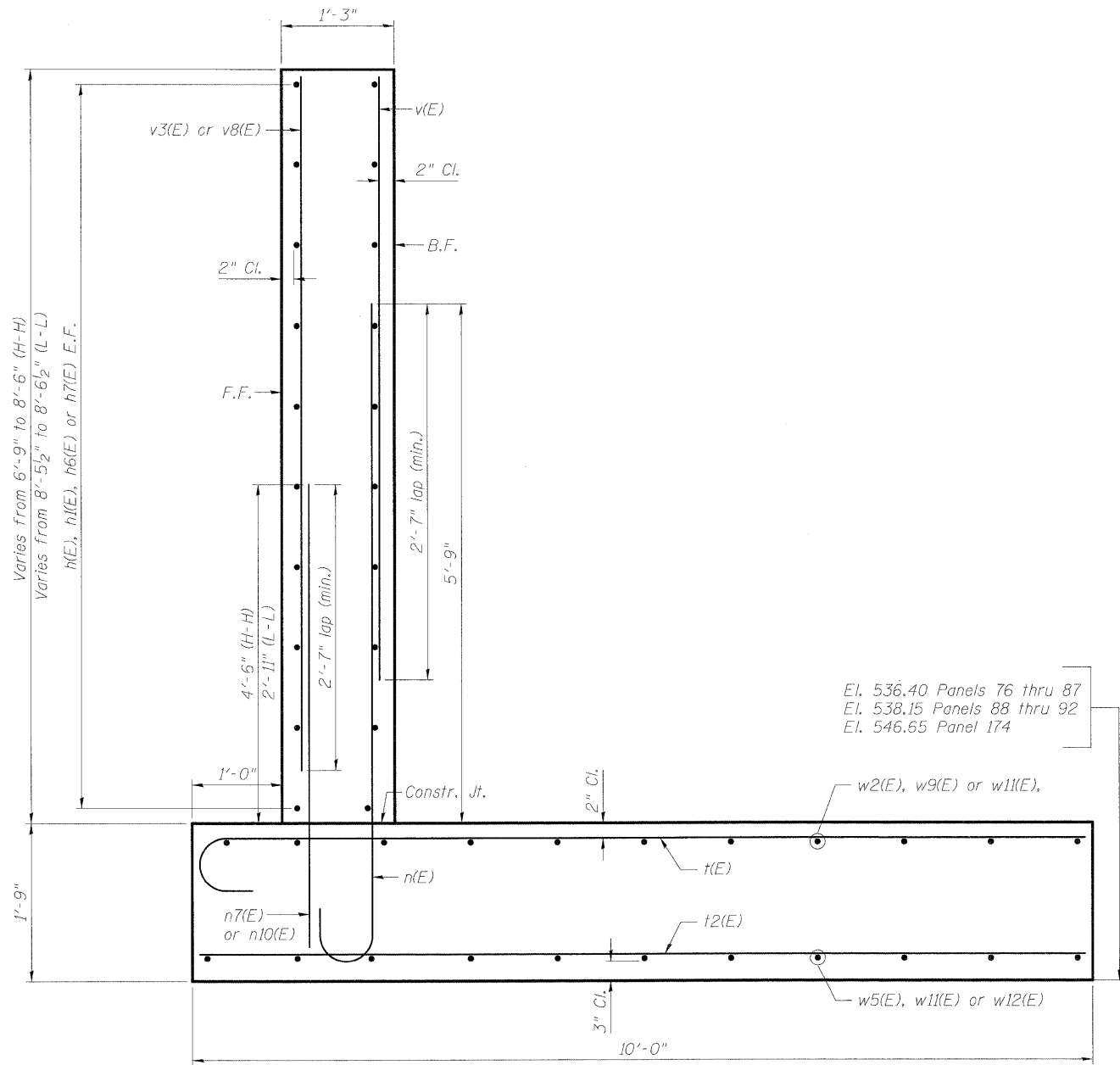

SECTION H-H & SECTION L-L
PANELS 76 THRU 92 (H-H)
PANEL 174 (L-L)

Max. Soil Pressure = 2.47 ksf

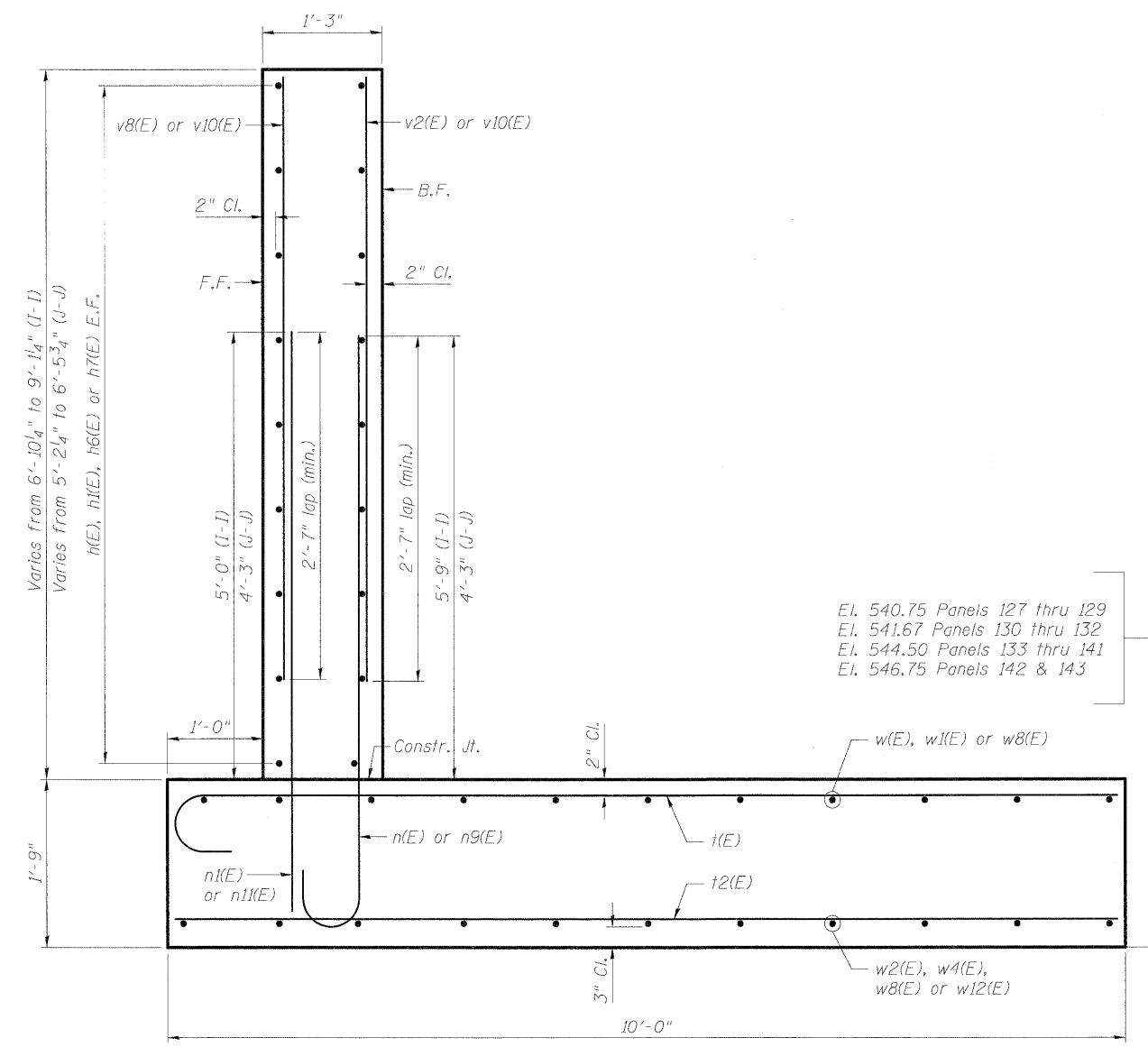

SECTION I-I & SECTION J-J
PANELS 127 THRU 132 & 139 THRU 143 (I-I)
PANELS 133 THRU 135 (J-J)

Max. Soil Pressure = 2.47 ksf

- NOTES:**
1. For Bill of Material see Sheet RW2-19.
 2. Reinforcement Bars designated (E) shall be Epoxy Coated.

- LEGEND:**
- F.F. = Front Face of Wall
 - B.F. = Back Face of Wall
 - E.F. = Each Face of Wall

SECTION AND DETAILS
STRUCTURE NO. 099-W027

DESIGNED	PMH
CHECKED	MJL
DRAWN	PMH
CHECKED	MJL

McDonough Associates Inc.
Engineers / Architects
130 East Randolph Street
Chicago, Illinois 60601
(312) 946-8600

SHEET NO. RW2-18 SHEETS RW2-31	F.A.I. RTE.	SECTION	COUNTY	TOTAL SHEETS	SHEET NO.
	55	(99-1&2) R-6	WILL	756	482
FED. ROAD DIST. NO.			ILLINOIS	FED. AID PROJECT	
CONTRACT NO. 60F12					

STATE OF ILLINOIS
DEPARTMENT OF TRANSPORTATION

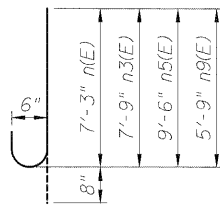

**BARS n(E), n3(E),
n5(E) & n9(E)**

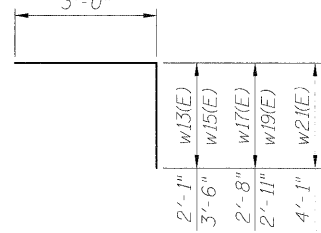

**BARS w13(E), w15(E),
w17(E), w19(E) & w21(E)**

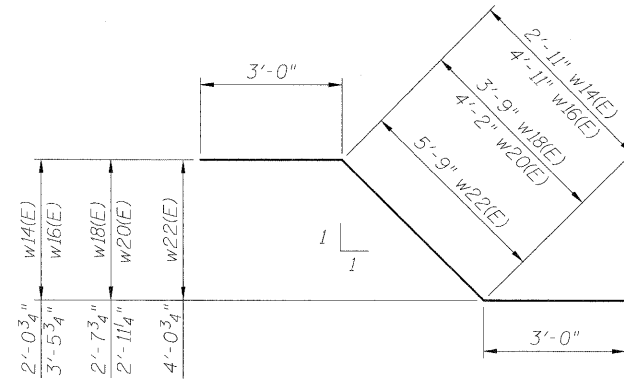

**BARS w14(E), w16(E),
w18(E), w20(E) & w22(E)**

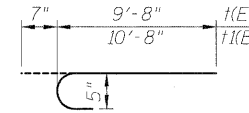

BARS t(E) & t1(E)

BILL OF MATERIAL

Bar	No.	Size	Length	Shape
h(E)	1954	#5	32'-9"	—
h1(E)	976	#5	29'-8"	—
h2(E)	20	#5	31'-5"	—
h3(E)	20	#5	35'-0"	—
h4(E)	18	#5	31'-10"	—
h5(E)	18	#5	21'-1"	—
h6(E)	132	#5	22'-4"	—
h7(E)	160	#5	25'-5"	—
h8(E)	46	#5	32'-4"	—
h9(E)	26	#5	19'-5"	—
h10(E)	26	#5	33'-11"	—
h11(E)	40	#5	30'-5"	—
h12(E)	40	#5	27'-4"	—
n(E)	2934	#6	7'-11"	U
n1(E)	1945	#5	5'-9"	—
n2(E)	213	#5	4'-11"	—
n3(E)	2061	#6	8'-5"	U
n4(E)	808	#5	5'-3"	—
n5(E)	762	#6	10'-2"	U
n6(E)	86	#5	4'-6"	—
n7(E)	1401	#5	6'-0"	—
n8(E)	461	#5	6'-11"	—
n9(E)	93	#6	6'-5"	—
n10(E)	31	#5	4'-5"	—
n11(E)	327	#5	6'-6"	—
t(E)	9204	#5	10'-3"	U
t1(E)	993	#5	11'-3"	U
t2(E)	4619	#5	9'-8"	—
t3(E)	497	#5	10'-8"	—

BILL OF MATERIAL (cont.)

Bar	No.	Size	Length	Shape
v(E)	1275	#5	5'-8"	—
v1(E)	3644	#5	7'-2"	—
v2(E)	1146	#5	6'-1"	—
v3(E)	705	#5	8'-1"	—
v4(E)	296	#5	9'-3"	—
v5(E)	1311	#5	6'-10"	—
v6(E)	514	#5	10'-3"	—
v7(E)	86	#5	9'-9"	—
v8(E)	1353	#5	6'-5"	—
v9(E)	513	#5	5'-2"	—
v10(E)	279	#5	4'-10"	—
w(E)	253	#5	20'-0"	—
w1(E)	55	#5	21'-1"	—
w2(E)	242	#5	23'-6"	—
w3(E)	176	#5	24'-4"	—
w4(E)	44	#5	25'-4"	—
w5(E)	231	#5	26'-1"	—
w6(E)	231	#5	26'-8"	—
w7(E)	407	#5	27'-5"	—
w8(E)	1175	#5	28'-1"	—
w9(E)	1229	#5	28'-9"	—
w10(E)	88	#5	28'-11"	—
w11(E)	154	#5	29'-8"	—
w12(E)	363	#5	30'-0"	—
w13(E)	22	#5	5'-1"	—
w14(E)	22	#5	8'-11"	—
w15(E)	11	#5	6'-6"	—
w16(E)	11	#5	10'-11"	—
w17(E)	11	#5	5'-8"	—
w18(E)	11	#5	9'-9"	—
w19(E)	44	#5	5'-11"	—
w20(E)	44	#5	10'-2"	—
w21(E)	11	#5	7'-1"	—
w22(E)	11	#5	11'-9"	—
Structure Excavation		Cu Yd	11,600	
Concrete Structures		Cu Yd	5,399.6	
Reinforcement Bars, Epoxy Coated		Pound	593,590	

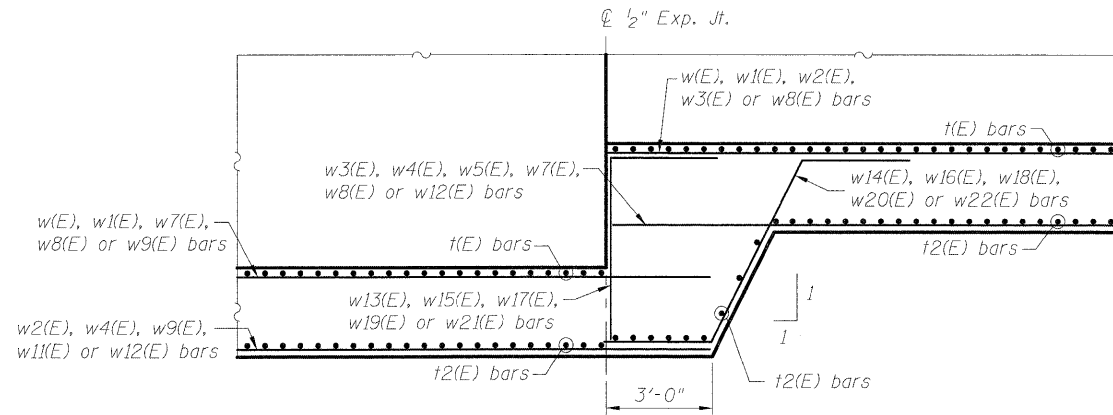

DETAIL 1

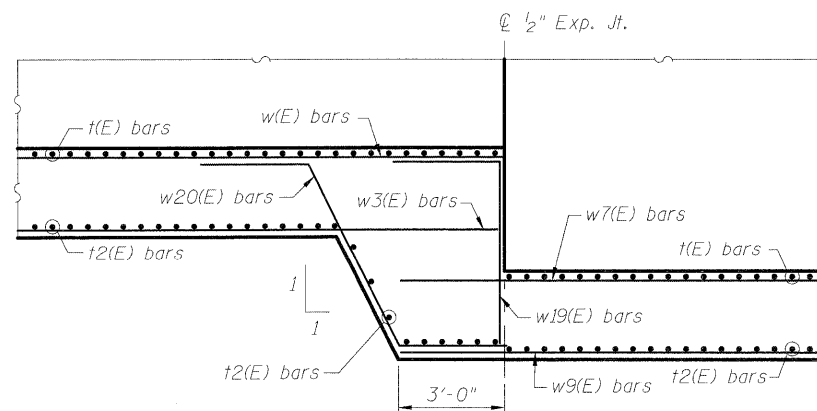

DETAIL 2

NOTES:

1. Reinforcement Bars designated (E) shall be Epoxy Coated.

DESIGNED	PMH
CHECKED	MJL
DRAWN	PMH
CHECKED	MJL

**BILL OF MATERIAL
STRUCTURE NO. 099-W027**

McDonough Associates Inc.
Engineers / Architects
130 East Randolph Street
Chicago, Illinois 60601
(312) 946-8600

SHEET NO. RW2-19 SHEETS RW2-31	F.A.I. RTE.	SECTION	COUNTY	TOTAL SHEETS	SHEET NO.
	55	(99-1&2) R-6	WILL	756	483
FED. ROAD DIST. NO.		ILLINOIS	FED. AID PROJECT		
CONTRACT NO. 60F12					

STATE OF ILLINOIS
DEPARTMENT OF TRANSPORTATION

BORING LOG RWN-01 Page 1 of 1
 WEI Job No.: 201-34-01
 Datum: NAVD
 Elevation: 535.66 ft
 North: 1723809.38 ft
 East: 1022797.57 ft
 Station: 3044+79.7
 Offset: 23.97 RT
 Client: McDonough Associates, Inc.
 Project: I-55 Interchange at Arsenal Road
 Location: T34, R9E, Sec. 21, 22, 28, 27, Will Co., Illinois

Profile Elevation (ft)	SOIL AND ROCK DESCRIPTION	Depth (ft)	Sample No.	SPT Values (blows/in)	Qu (tsf)	Moisture Content (%)	Profile Elevation (ft)	SOIL AND ROCK DESCRIPTION	Depth (ft)	Sample No.	SPT Values (blows/in)	Qu (tsf)	Moisture Content (%)
535.43	43-inch thick, brown SILTY LOAM --TOPSOIL--	0											
	Loose to medium dense, brown SANDY LOAM, with dolostone rock fragments	1	3										
	--WEATHERED BEDROCK--	3											
	--AUGER REFUSAL @ 5' 6"--	7											
		2											
		8											
		12											
530.2	Boring terminated at 5.50 ft	5.50											

GENERAL NOTES	WATER LEVEL DATA
Begin Drilling: 08-27-2008 Complete Drilling: 08-27-2008 Drilling Contractor: Wang Testing Service, Drill Rig: Mobile B-57 TMR Driller: K & J, Logger: F. Bozga, Checked by: E. Datz Drilling Method: 3.25" IDA HSA; Boring backfilled with bentonite upon completion	While Drilling: DRY At Completion of Drilling: DRY Time After Drilling: NA Depth to Water: NA The stratification lines represent the approximate boundary between soil types; the actual transition may be gradual.

BORING LOG RWN-02 Page 1 of 1
 WEI Job No.: 201-34-01
 Datum: NAVD
 Elevation: 535.88 ft
 North: 1723971.03 ft
 East: 1022793.98 ft
 Station: 3046+41.38
 Offset: 25.79 RT
 Client: McDonough Associates, Inc.
 Project: I-55 Interchange at Arsenal Road
 Location: T34, R9E, Sec. 21, 22, 28, 27, Will Co., Illinois

Profile Elevation (ft)	SOIL AND ROCK DESCRIPTION	Depth (ft)	Sample No.	SPT Values (blows/in)	Qu (tsf)	Moisture Content (%)	Profile Elevation (ft)	SOIL AND ROCK DESCRIPTION	Depth (ft)	Sample No.	SPT Values (blows/in)	Qu (tsf)	Moisture Content (%)
535.43	43-inch thick brown SANDY LOAM --TOPSOIL--	0											
	Loose to very dense, brown SANDY LOAM with gravel and dolostone rock fragments	1	4										
		2											
		4											
		8											
		20											
532.2	--WEATHERED BEDROCK--	20											
532.7	--AUGER REFUSAL @ 5'--	5											
	Boring terminated at 5.00 ft	5.00											

GENERAL NOTES	WATER LEVEL DATA
Begin Drilling: 08-21-2008 Complete Drilling: 08-21-2008 Drilling Contractor: Wang Testing Service, Drill Rig: Mobile B-57 TMR Driller: K & J, Logger: F. Bozga, Checked by: E. Datz Drilling Method: 3.25" IDA HSA; Boring backfilled with bentonite upon completion	While Drilling: DRY At Completion of Drilling: DRY Time After Drilling: NA Depth to Water: NA The stratification lines represent the approximate boundary between soil types; the actual transition may be gradual.

BORING LOG RWN-03 Page 1 of 1
 WEI Job No.: 201-34-01
 Datum: NAVD
 Elevation: 535.44 ft
 North: 1724108.33 ft
 East: 1022789.90 ft
 Station: 300+53.01
 Offset: 50.23 LT
 Client: McDonough Associates, Inc.
 Project: I-55 Interchange at Arsenal Road
 Location: T34, R9E, Sec. 21, 22, 28, 27, Will Co., Illinois

Profile Elevation (ft)	SOIL AND ROCK DESCRIPTION	Depth (ft)	Sample No.	SPT Values (blows/in)	Qu (tsf)	Moisture Content (%)	Profile Elevation (ft)	SOIL AND ROCK DESCRIPTION	Depth (ft)	Sample No.	SPT Values (blows/in)	Qu (tsf)	Moisture Content (%)
534.4	7-inch thick, brown SILTY LOAM --TOPSOIL--	0											
	Stiff to very stiff, brown SILTY CLAY LOAM	1	5										
	--GRAVEL=7.8%--	3											
	--SAND=18.5%--	6											
	--SILT=46.3%--												
	--CLAY=27.4%--												
		2											
531.2	Brown DOLOSTONE rock fragments	24											
530.4	--WEATHERED BEDROCK--	5											
	--AUGER REFUSAL @ 5.0'--												
	Poor, highly weathered, light gray DOLOSTONE	3											
	--BEDROCK--												
	--RUN #1 (5' to 10')--												
	--REC=100%--												
	--ROD=33%--												
	--Qu=839.5 tsf--												
526.4	Boring terminated at 10.00 ft	10.00											

GENERAL NOTES	WATER LEVEL DATA
Begin Drilling: 08-18-2008 Complete Drilling: 08-18-2008 Drilling Contractor: Wang Testing Service, Drill Rig: Mobile B-57 TMR Driller: K & J, Logger: E. Datz, Checked by: E. Datz Drilling Method: 3.25" IDA HSA; Boring backfilled with bentonite upon completion	While Drilling: DRY At Completion of Drilling: DRY Time After Drilling: NA Depth to Water: NA The stratification lines represent the approximate boundary between soil types; the actual transition may be gradual.

DESIGNED	PMH
CHECKED	MJL
DRAWN	PMH
CHECKED	MJL

McDonough Associates Inc.
Engineers / Architects
130 East Randolph Street
Chicago, Illinois 60601
(312) 946-8600

SHEET NO. RW2-20 SHEETS RW2-31	F.A.I. RTE.	SECTION	COUNTY	TOTAL SHEETS	SHEET NO.
	55	(99-1&2) R-6	WILL	756	484
FED. ROAD DIST. NO.			ILLINOIS FED. AID PROJECT		
CONTRACT NO. 60F12					

SOIL BORINGS
STRUCTURE NO. 099-W027

STATE OF ILLINOIS
DEPARTMENT OF TRANSPORTATION

BORING LOG RWN-04 Page 1 of 1

Wang Engineering, Inc.
1145 Main Street
Lombard, IL 60148
Telephone: 630 953-9928
Fax: 630 953-9938

WEI Job No.: 201-34-01

Datum: NAVD
Elevation: 535.96 ft
North: 1724258.51 ft
East: 1022786.78 ft
Station: 902+42.21
Offset: 44.3 LT

Client: McDonough Associates, Inc.
Project: I-55 Interchange at Arsenal Road
Location: T34, R9E, Sec. 21, 22, 28, 27, Will Co., Illinois

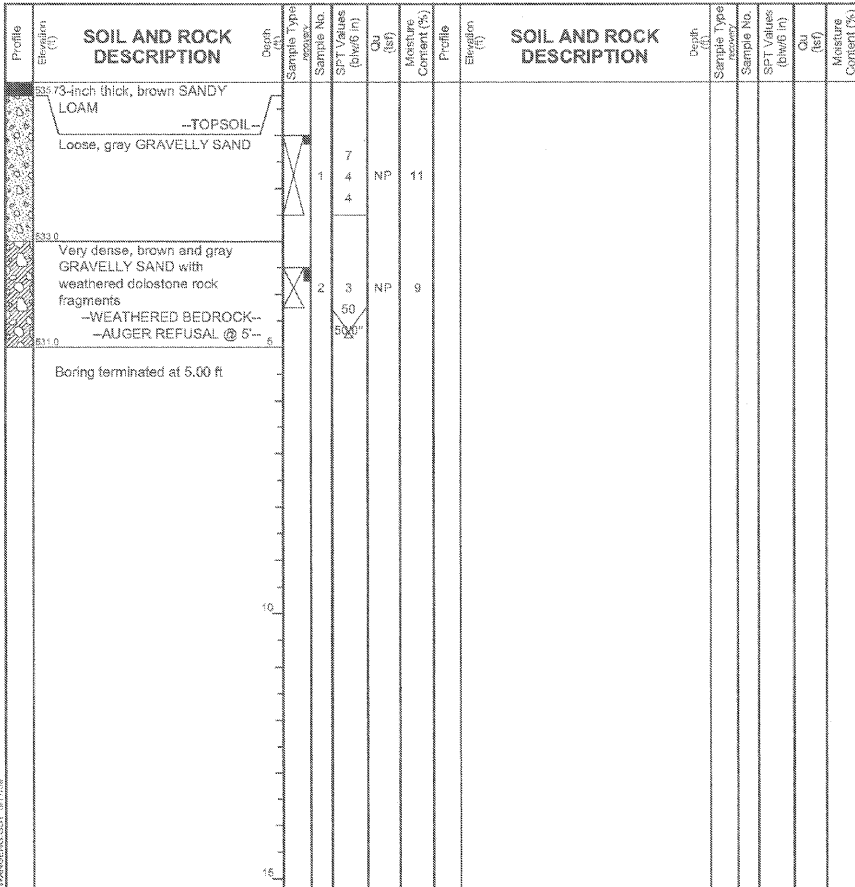

GENERAL NOTES		WATER LEVEL DATA	
Begin Drilling	08-21-2008	Complete Drilling	08-21-2008
Drilling Contractor	Wang Testing Service	Drill Rig	Mobile B-57 TMR
Driller	K & J	Logger	F. Bozga
Checked by	E. Datz	Time After Drilling	NA
Drilling Method	3.25" IDA HSA; Boring backfilled with bentonite upon completion	Depth to Water	NA

BORING LOG RWN-05 Page 1 of 1

Wang Engineering, Inc.
1145 Main Street
Lombard, IL 60148
Telephone: 630 953-9928
Fax: 630 953-9938

WEI Job No.: 201-34-01

Datum: NAVD
Elevation: 536.01 ft
North: 1724408.22 ft
East: 1022781.97 ft
Station: 903+82.53
Offset: 43.91 LT

Client: McDonough Associates, Inc.
Project: I-55 Interchange at Arsenal Road
Location: T34, R9E, Sec. 21, 22, 28, 27, Will Co., Illinois

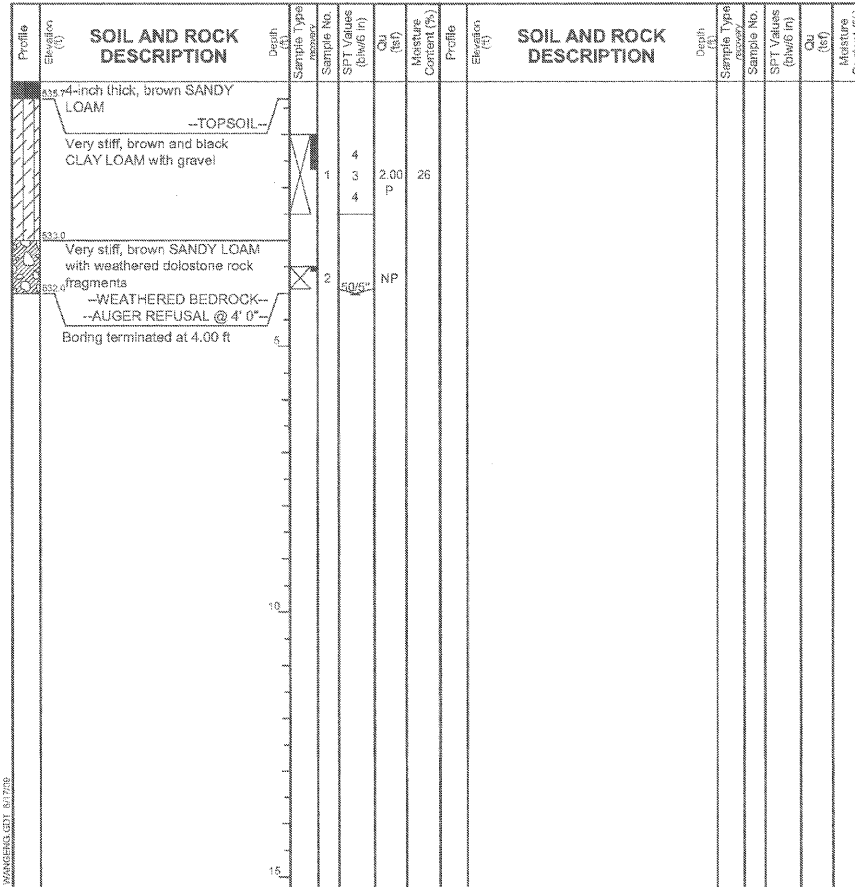

GENERAL NOTES		WATER LEVEL DATA	
Begin Drilling	08-21-2008	Complete Drilling	08-21-2008
Drilling Contractor	Wang Testing Service	Drill Rig	Mobile B-57 TMR
Driller	K & J	Logger	F. Bozga
Checked by	E. Datz	Time After Drilling	NA
Drilling Method	3.25" IDA HSA; Boring backfilled with bentonite upon completion	Depth to Water	NA

BORING LOG RWN-06 Page 1 of 1

Wang Engineering, Inc.
1145 Main Street
Lombard, IL 60148
Telephone: 630 953-9928
Fax: 630 953-9938

WEI Job No.: 201-34-01

Datum: NAVD
Elevation: 535.61 ft
North: 1724563.04 ft
East: 1022777.48 ft
Station: 905+60.03
Offset: 41.20 LT

Client: McDonough Associates, Inc.
Project: I-55 Interchange at Arsenal Road
Location: T34, R9E, Sec. 21, 22, 28, 27, Will Co., Illinois

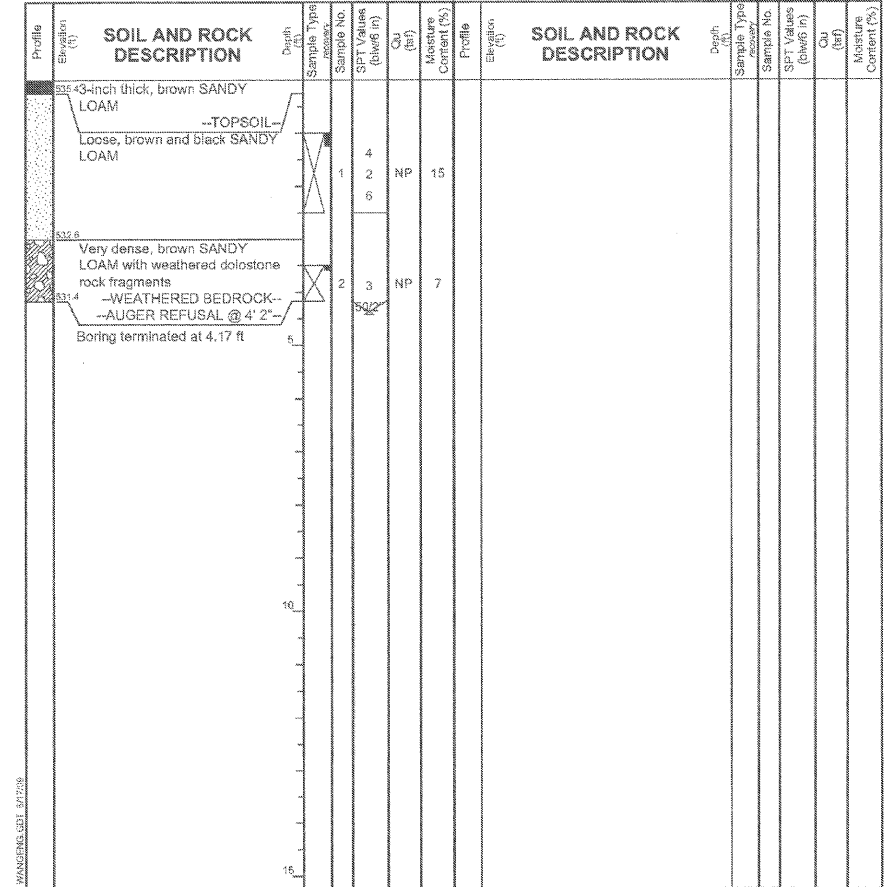

GENERAL NOTES		WATER LEVEL DATA	
Begin Drilling	08-21-2008	Complete Drilling	08-21-2008
Drilling Contractor	Wang Testing Service	Drill Rig	Mobile B-57 TMR
Driller	K & J	Logger	F. Bozga
Checked by	E. Datz	Time After Drilling	NA
Drilling Method	3.25" IDA HSA; Boring backfilled with bentonite upon completion	Depth to Water	NA

DESIGNED	PMH
CHECKED	MJL
DRAWN	PMH
CHECKED	MJL

**SOIL BORINGS
STRUCTURE NO. 099-W027**

McDonough Associates Inc.
Engineers / Architects
130 East Randolph Street
Chicago, Illinois 60601
(312) 946-8600

SHEET NO. RW2-21 SHEETS RW2-31	F.A.I. RTE.	SECTION	COUNTY	TOTAL SHEETS	SHEET NO.
	55	(99-1&2) R-6	WILL	756	485
FED. ROAD DIST. NO.			ILLINOIS FED. AID PROJECT		
CONTRACT NO. 60F12					

STATE OF ILLINOIS
DEPARTMENT OF TRANSPORTATION

BORING LOG RWN-07
WEI Job No.: 201-34-01
Client: McDonough Associates, Inc.
Project: I-55 Interchange at Arsenal Road
Location: T34, R9E, Sec. 21, 22, 28, 27, Will Co., Illinois

Datum: NAVD
Elevation: 535.91 ft
North: 1724709.08 ft
East: 1022773.84 ft
Station: 906+92.52
Offset: 32.5 LT

Profile Elevation (ft)	SOIL AND ROCK DESCRIPTION	Depth (ft)	Sample No.	SPT Values (blows/in)	Qu (tsf)	Moisture Content (%)	Profile Elevation (ft)	SOIL AND ROCK DESCRIPTION	Depth (ft)	Sample No.	SPT Values (blows/in)	Qu (tsf)	Moisture Content (%)
533.94	4-inch thick, brown and black SILTY LOAM --TOPSOIL--												
	Very stiff, brown and black SILTY CLAY LOAM --A-6 (11)-- --LL=40%, PL=21%-- --GRAVEL=11.6%-- --SAND=22.8%-- --SILT=46.0%-- --CLAY=19.3%--	1	3	3.25	18								
532.9	Very dense, brown SANDY LOAM, with dolostone rock fragments --WEATHERED BEDROCK-- --AUGER REFUSAL @ 5' 0"--	2	6	NP	11								
530.9	Boring terminated at 5.00 ft												

GENERAL NOTES	WATER LEVEL DATA
Begin Drilling: 08-21-2008 Complete Drilling: 08-21-2008 Drilling Contractor: Wang Testing Service Drill Rig: Mobile B-57 TMR Driller: K & J Logger: F. Bozga Checked by: E. Datz Drilling Method: 3.25" IDA HSA; Boring backfilled with bentonite upon completion.	While Drilling: <input checked="" type="checkbox"/> DRY At Completion of Drilling: <input checked="" type="checkbox"/> DRY Time After Drilling: NA Depth to Water: <input checked="" type="checkbox"/> NA The stratification lines represent the approximate boundary between soil types; the actual transition may be gradual.

BORING LOG RWN-08
WEI Job No.: 201-34-01
Client: McDonough Associates, Inc.
Project: I-55 Interchange at Arsenal Road
Location: T34, R9E, Sec. 21, 22, 28, 27, Will Co., Illinois

Datum: NAVD
Elevation: 535.88 ft
North: 1724854.88 ft
East: 1022768.88 ft
Station: 908+39.71
Offset: 35.8 LT

Profile Elevation (ft)	SOIL AND ROCK DESCRIPTION	Depth (ft)	Sample No.	SPT Values (blows/in)	Qu (tsf)	Moisture Content (%)	Profile Elevation (ft)	SOIL AND ROCK DESCRIPTION	Depth (ft)	Sample No.	SPT Values (blows/in)	Qu (tsf)	Moisture Content (%)
533.4	6-inch thick, brown and black SILTY LOAM --TOPSOIL--												
	Very stiff, brown and black SILTY CLAY LOAM with gravel --A-7-6 (16)-- --LL=44%, PL=20%-- --GRAVEL=5.7%-- --SAND=19.0%-- --SILT=49.2%-- --CLAY=26.1%--	1	3	3.75	16								
532.6	Boring terminated at 15.50 ft												
532.6	Brown GRAVELLY SAND with dolostone rock fragments --WEATHERED BEDROCK-- --AUGER REFUSAL @ 5' 6"--	2	5	2.00	13								
532.6	Poor, brown and gray, weathered DOLOSTONE --BEDROCK-- --RUN #1 (5.5' to 10.5')-- --REC=100%-- --RQD=35%--	3											
525.4	--RUN #2 (10.5' to 15.5')-- --REC=100%-- --RQD=72%--	4											

GENERAL NOTES	WATER LEVEL DATA
Begin Drilling: 08-18-2008 Complete Drilling: 08-18-2008 Drilling Contractor: Wang Testing Service Drill Rig: Mobile B-57 TMR Driller: K & J Logger: E. Datz Checked by: E. Datz Drilling Method: 3.25" IDA HSA; Boring backfilled with bentonite upon completion.	While Drilling: <input checked="" type="checkbox"/> DRY At Completion of Drilling: <input checked="" type="checkbox"/> DRY Time After Drilling: NA Depth to Water: <input checked="" type="checkbox"/> NA The stratification lines represent the approximate boundary between soil types; the actual transition may be gradual.

BORING LOG RWN-09
WEI Job No.: 201-34-01
Client: McDonough Associates, Inc.
Project: I-55 Interchange at Arsenal Road
Location: T34, R9E, Sec. 21, 22, 28, 27, Will Co., Illinois

Datum: NAVD
Elevation: 536.28 ft
North: 1725002.53 ft
East: 1022764.59 ft
Station: 910+59.88
Offset: 14.20 LT

Profile Elevation (ft)	SOIL AND ROCK DESCRIPTION	Depth (ft)	Sample No.	SPT Values (blows/in)	Qu (tsf)	Moisture Content (%)	Profile Elevation (ft)	SOIL AND ROCK DESCRIPTION	Depth (ft)	Sample No.	SPT Values (blows/in)	Qu (tsf)	Moisture Content (%)
535.93	13-inch thick, brown SANDY LOAM --TOPSOIL--												
	Loose, brown SANDY LOAM, with gravel --FILL--	1	4	NP	12								
533.3	Stiff, brown, black and gray SANDY CLAY LOAM with gravel, sand and dolostone rock fragments	2	4										
531.3	--WEATHERED BEDROCK-- --AUGER REFUSAL @ 5' 2"--	3	2		1.25								
528.3	Boring terminated at 5.17 ft												

GENERAL NOTES	WATER LEVEL DATA
Begin Drilling: 08-21-2008 Complete Drilling: 08-21-2008 Drilling Contractor: Wang Testing Service Drill Rig: Mobile B-57 TMR Driller: K & J Logger: F. Bozga Checked by: E. Datz Drilling Method: 3.25" IDA HSA; Boring backfilled with bentonite upon completion.	While Drilling: <input checked="" type="checkbox"/> DRY At Completion of Drilling: <input checked="" type="checkbox"/> DRY Time After Drilling: NA Depth to Water: <input checked="" type="checkbox"/> NA The stratification lines represent the approximate boundary between soil types; the actual transition may be gradual.

DESIGNED	PMH
CHECKED	MJL
DRAWN	PMH
CHECKED	MJL

**SOIL BORINGS
STRUCTURE NO. 099-W027**

McDonough Associates Inc.
Engineers / Architects
130 East Randolph Street
Chicago, Illinois 60601
(312) 946-8600

SHEET NO. RW2-22 SHEETS RW2-31	F.A.I. RTE.	SECTION	COUNTY	TOTAL SHEETS	SHEET NO.
	55	(99-1&2) R-6	WILL	756	486
CONTRACT NO. 60F12					
FED. ROAD DIST. NO. ILLINOIS FED. AID PROJECT					

STATE OF ILLINOIS
DEPARTMENT OF TRANSPORTATION

BORING LOG RWN-10
WEI Job No.: 201-34-01
Client: McDonough Associates, Inc.
Project: I-55 Interchange at Arsenal Road
Location: T34, R9E, Sec. 21, 22, 28, 27, Will Co., Illinois

Datum: NAVD
Elevation: 536.63 ft
North: 1725153.93 ft
East: 1022760.89 ft
Station: 011+38.8
Offset: 29.59 LT

Profile Elevation (ft)	SOIL AND ROCK DESCRIPTION	Depth (ft)	Sample No.	SPT Values (blows/in)	Qu (tsf)	Moisture Content (%)	Profile Elevation (ft)	SOIL AND ROCK DESCRIPTION	Depth (ft)	Sample No.	SPT Values (blows/in)	Qu (tsf)	Moisture Content (%)
536.63	3-4 inch thick, black SANDY LOAM --TOPSOIL--												
536.5	Brown, black and gray SANDY LOAM, with gravel --FILL--	1	3	NP	14								
	Stiff, brown, black and gray CLAY LOAM	4											
532.8	Medium dense, brown SANDY LOAM, some rock fragments --WEATHERED BEDROCK-- --AUGER REFUSAL @ 8--	2	2	1.25	11								
532.8	Boring terminated at 6.00 ft												

GENERAL NOTES	WATER LEVEL DATA
Begin Drilling: 08-21-2008 Complete Drilling: 08-21-2008 Drilling Contractor: Wang Testing Service Drill Rig: Mobile B-57 TMR Driller: K & J Logger: F. Bozga Checked by: E. Datz Drilling Method: 3.25" IDA HSA; Boring backfilled with bentonite upon completion	While Drilling: DRY At Completion of Drilling: DRY Time After Drilling: NA Depth to Water: NA

BORING LOG RWN-11
WEI Job No.: 201-34-01
Client: McDonough Associates, Inc.
Project: I-55 Interchange at Arsenal Road
Location: T34, R9E, Sec. 21, 22, 28, 27, Will Co., Illinois

Datum: NAVD
Elevation: 537.19 ft
North: 1725294.78 ft
East: 1022757.90 ft
Station: 012+79.63
Offset: 25.89 LT

Profile Elevation (ft)	SOIL AND ROCK DESCRIPTION	Depth (ft)	Sample No.	SPT Values (blows/in)	Qu (tsf)	Moisture Content (%)	Profile Elevation (ft)	SOIL AND ROCK DESCRIPTION	Depth (ft)	Sample No.	SPT Values (blows/in)	Qu (tsf)	Moisture Content (%)
535.5	4-inch thick, black SILTY LOAM --TOPSOIL--												
	Stiff, brown CLAY LOAM --FILL--	1	7	1.75	25								
604.2	Medium dense to very dense, brown GRAVELLY SAND	2	6	NP	5								
631.7	Medium dense to very dense, brown GRAVELLY SAND with DOLOSTONE rock fragments --WEATHERED BEDROCK-- --AUGER REFUSAL @ 7--	3	12	NP	7								
632.2	Boring terminated at 7.00 ft												

GENERAL NOTES	WATER LEVEL DATA
Begin Drilling: 08-27-2008 Complete Drilling: 08-27-2008 Drilling Contractor: Wang Testing Service Drill Rig: Mobile B-57 TMR Driller: K & J Logger: F. Bozga Checked by: E. Datz Drilling Method: 3.25" IDA HSA; Boring backfilled with bentonite upon completion	While Drilling: DRY At Completion of Drilling: DRY Time After Drilling: NA Depth to Water: NA

BORING LOG RWN-12
WEI Job No.: 201-34-01
Client: McDonough Associates, Inc.
Project: I-55 Interchange at Arsenal Road
Location: T34, R9E, Sec. 21, 22, 28, 27, Will Co., Illinois

Datum: NAVD
Elevation: 538.24 ft
North: 1725451.18 ft
East: 1022753.50 ft
Station: 014+35.50
Offset: 24.79 LT

Profile Elevation (ft)	SOIL AND ROCK DESCRIPTION	Depth (ft)	Sample No.	SPT Values (blows/in)	Qu (tsf)	Moisture Content (%)	Profile Elevation (ft)	SOIL AND ROCK DESCRIPTION	Depth (ft)	Sample No.	SPT Values (blows/in)	Qu (tsf)	Moisture Content (%)
538.24	3-4 inch thick, black SILTY LOAM --TOPSOIL--												
	Black and brown SANDY CLAY LOAM	1	3	2.00	16								
535.2	Medium dense, brown SANDY LOAM	2	4	NP	17								
532.7	Stiff, black SANDY CLAY LOAM with DOLOSTONE rock fragments --WEATHERED BEDROCK-- --AUGER REFUSAL @ 7.5--	3	10	1.75	22								
532.7	Boring terminated at 7.50 ft												

GENERAL NOTES	WATER LEVEL DATA
Begin Drilling: 08-27-2008 Complete Drilling: 08-27-2008 Drilling Contractor: Wang Testing Service Drill Rig: Mobile B-57 TMR Driller: K & J Logger: F. Bozga Checked by: E. Datz Drilling Method: 3.25" IDA HSA; Boring backfilled with bentonite upon completion	While Drilling: DRY At Completion of Drilling: DRY Time After Drilling: NA Depth to Water: NA

DESIGNED	PMH
CHECKED	MJL
DRAWN	PMH
CHECKED	MJL

**SOIL BORINGS
STRUCTURE NO. 099-W027**



SHEET NO. RW2-23 SHEETS RW2-31	F.A.I. RTE.	SECTION	COUNTY	TOTAL SHEETS	SHEET NO.
	55	(99-1&2) R-6	WILL	756	487
CONTRACT NO. 60F12					
FED. ROAD DIST. NO. ILLINOIS FED. AID PROJECT					

STATE OF ILLINOIS
DEPARTMENT OF TRANSPORTATION

BORING LOG RWN-13 Page 1 of 1

Wang Engineering, Inc.
wangeng@wangeng.com
1145 Main Street
Lombard, IL 60148
Telephone: 630 953-9928
Fax: 630 953-9938

WEI Job No.: 201-34-01

Datum: NAVD
Elevation: 539.18 ft
North: 1725635.72 ft
East: 1022747.48 ft
Station: 916+20.22
Offset: 25.76 LT

Client: **McDonough Associates, Inc.**
Project: **I-55 Interchange at Arsenal Road**
Location: **T34, R9E, Sec. 21, 22, 28, 27, Will Co., Illinois**

Profile Elevation (ft)	SOIL AND ROCK DESCRIPTION	Depth (ft)	Sample Type	Sample No.	SPT Values (blows/in)	Cu (tsf)	Moisture Content (%)	Profile Elevation (ft)	SOIL AND ROCK DESCRIPTION	Depth (ft)	Sample Type	Sample No.	SPT Values (blows/in)	Cu (tsf)	Moisture Content (%)
535.5	7-inch thick, brown SILTY LOAM --TOPSOIL--														
	Very stiff, brown CLAY LOAM	1	4	5	2.00	13									
535.6	Very dense, brown GRAVELLY SAND with dolostone rock fragments* --WEATHERED BEDROCK-- --AUGER REFUSAL @ 4'--	2	3	NP		20									
	Very poor to poor, highly weathered, light gray DOLOSTONE --BEDROCK-- --RUN #1 (4' to 9')-- --REC=67%-- --ROD=16%--	3													
530.2	Boring terminated at 9.00 ft	10													

GENERAL NOTES		WATER LEVEL DATA	
Begin Drilling: 08-13-2008	Complete Drilling: 08-13-2008	While Drilling: <input checked="" type="checkbox"/> DRY	
Drilling Contractor: Wang Testing Service	Drill Rig: Mobile B-57 TMR	At Completion of Drilling: <input checked="" type="checkbox"/> DRY	
Driller: K & J	Logger: E. Datz	Time After Drilling: NA	
Checked by: E. Datz		Depth to Water: <input checked="" type="checkbox"/> NA	
Drilling Method: 3.25" IDA HSA; Boring backfilled with bentonite upon completion.		The stratification lines represent the approximate boundary between soil types; the actual transition may be gradual.	

BORING LOG RWN-14 Page 1 of 1

Wang Engineering, Inc.
wangeng@wangeng.com
1145 Main Street
Lombard, IL 60148
Telephone: 630 953-9928
Fax: 630 953-9938

WEI Job No.: 201-34-01

Datum: NAVD
Elevation: 540.84 ft
North: 1725763.91 ft
East: 1022745.01 ft
Station: 917+68.43
Offset: 24.14 LT

Client: **McDonough Associates, Inc.**
Project: **I-55 Interchange at Arsenal Road**
Location: **T34, R9E, Sec. 21, 22, 28, 27, Will Co., Illinois**

Profile Elevation (ft)	SOIL AND ROCK DESCRIPTION	Depth (ft)	Sample Type	Sample No.	SPT Values (blows/in)	Cu (tsf)	Moisture Content (%)	Profile Elevation (ft)	SOIL AND ROCK DESCRIPTION	Depth (ft)	Sample Type	Sample No.	SPT Values (blows/in)	Cu (tsf)	Moisture Content (%)
539.8	12-inch thick SILTY LOAM --TOPSOIL--														
	Stiff, black CLAY to CLAY LOAM	1	4	3	1.25	15									
537.6	Very dense, black SILTY LOAM with dolostone rock fragments --WEATHERED BEDROCK-- --AUGER REFUSAL @ 5' 4"--	2	39	NP		8									
535.1	Boring terminated at 5.33 ft	5													

GENERAL NOTES		WATER LEVEL DATA	
Begin Drilling: 08-20-2008	Complete Drilling: 08-20-2008	While Drilling: <input checked="" type="checkbox"/> DRY	
Drilling Contractor: Wang Testing Service	Drill Rig: Mobile B-57 TMR	At Completion of Drilling: <input checked="" type="checkbox"/> DRY	
Driller: K & J	Logger: E. Datz	Time After Drilling: NA	
Checked by: E. Datz		Depth to Water: <input checked="" type="checkbox"/> NA	
Drilling Method: 3.25" IDA HSA; Boring backfilled with bentonite upon completion.		The stratification lines represent the approximate boundary between soil types; the actual transition may be gradual.	

BORING LOG RWN-15 Page 1 of 1

Wang Engineering, Inc.
wangeng@wangeng.com
1145 Main Street
Lombard, IL 60148
Telephone: 630 953-9928
Fax: 630 953-9938

WEI Job No.: 201-34-01

Datum: NAVD
Elevation: 541.44 ft
North: 1725624.27 ft
East: 1022741.01 ft
Station: 919+08.85
Offset: 24.29 LT

Client: **McDonough Associates, Inc.**
Project: **I-55 Interchange at Arsenal Road**
Location: **T34, R9E, Sec. 21, 22, 28, 27, Will Co., Illinois**

Profile Elevation (ft)	SOIL AND ROCK DESCRIPTION	Depth (ft)	Sample Type	Sample No.	SPT Values (blows/in)	Cu (tsf)	Moisture Content (%)	Profile Elevation (ft)	SOIL AND ROCK DESCRIPTION	Depth (ft)	Sample Type	Sample No.	SPT Values (blows/in)	Cu (tsf)	Moisture Content (%)
540.4	12-inch thick BLACK SILTY LOAM --TOPSOIL--														
	Very stiff, black CLAY LOAM with gravel --A-7-6 (3)-- --LL=47%, PL=25%-- --GRAVEL=46.5%-- --SAND=17.2%-- --SILT=23.8%-- --CLAY=12.5%--	1	4	2.00	29										
537.7	Very dense, black SILTY LOAM with dolostone rock fragments --WEATHERED BEDROCK-- --AUGER REFUSAL @ 5.5'--	2	10	2.90	27										
535.8	Boring terminated at 5.50 ft	5													

GENERAL NOTES		WATER LEVEL DATA	
Begin Drilling: 08-20-2008	Complete Drilling: 08-20-2008	While Drilling: <input checked="" type="checkbox"/> DRY	
Drilling Contractor: Wang Testing Service	Drill Rig: Mobile B-57 TMR	At Completion of Drilling: <input checked="" type="checkbox"/> DRY	
Driller: K & J	Logger: E. Datz	Time After Drilling: NA	
Checked by: E. Datz		Depth to Water: <input checked="" type="checkbox"/> NA	
Drilling Method: 3.25" IDA HSA; Boring backfilled with bentonite upon completion.		The stratification lines represent the approximate boundary between soil types; the actual transition may be gradual.	

DESIGNED	PMH
CHECKED	MJL
DRAWN	PMH
CHECKED	MJL

SOIL BORINGS
STRUCTURE NO. 099-W027

McDonough Associates Inc.
Engineers / Architects
130 East Randolph Street
Chicago, Illinois 60601
(312) 946-8600

SHEET NO. RW2-24 SHEETS RW2-31	F.A.I. RTE.	SECTION	COUNTY	TOTAL SHEETS	SHEET NO.
	55	(99-1&2) R-6	WILL	756	488
FED. ROAD DIST. NO.			ILLINOIS	FED. AID PROJECT	
CONTRACT NO. 60F12					

STATE OF ILLINOIS
DEPARTMENT OF TRANSPORTATION

BORING LOG RWN-16 Page 1 of 1

Wang Engineering, Inc.
wangeng@wangeng.com
1145 Main Street
Lombard, IL 60148
Telephone: 630 953-9928
Fax: 630 953-9938

WEI Job No.: 201-34-01
Client: McDonough Associates, Inc.
Project: I-55 Interchange at Arsenal Road
Location: T34, R9E, Sec. 21, 22, 28, 27, Will Co., Illinois

Datum: NAVD
Elevation: 541.70 ft
North: 1726053.40 ft
East: 1022736.84 ft
Station: 920+38.05
Offset: 25.1 LT

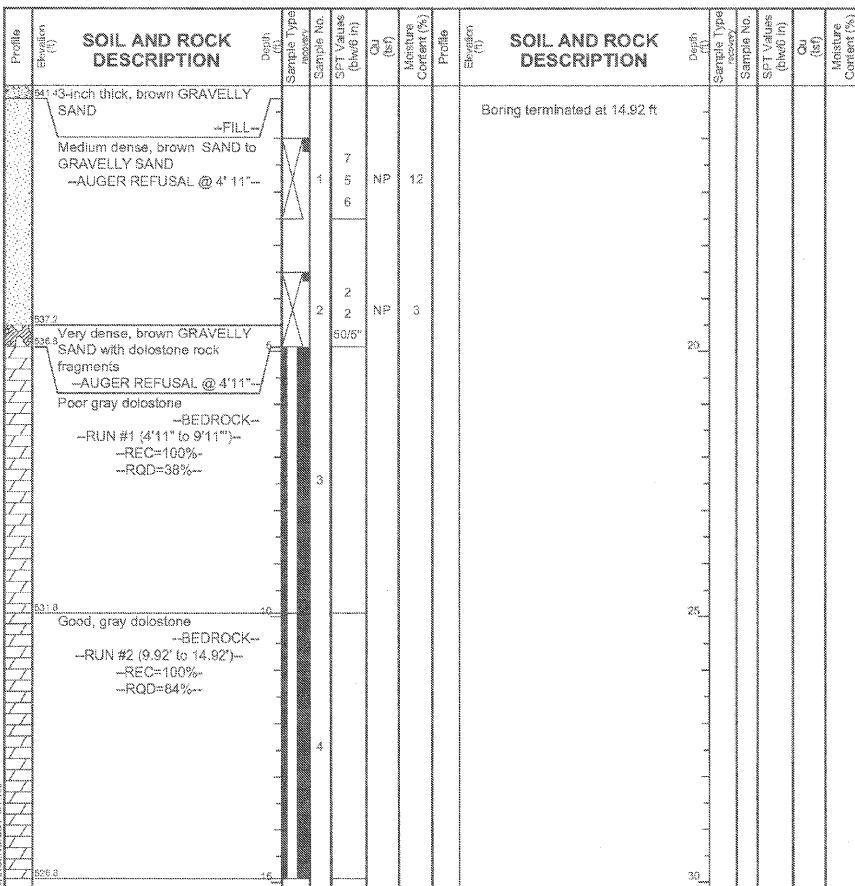

GENERAL NOTES		WATER LEVEL DATA	
Begin Drilling	08-21-2008	Complete Drilling	08-21-2008
Drilling Contractor	Wang Testing Service	Drill Rig	Mobile B-57 TMR
Driller	K & J	Logger	F. Bozga
Checked by	E. Datz	Depth to Water	NA
Drilling Method	3.25" IDA HSA; Boring backfilled with bentonite upon completion	At Completion of Drilling	DRY
		Time After Drilling	NA
		Drilling Method	3.25" IDA HSA; Boring backfilled with bentonite upon completion

BORING LOG RWN-17 Page 1 of 1

Wang Engineering, Inc.
wangeng@wangeng.com
1145 Main Street
Lombard, IL 60148
Telephone: 630 953-9928
Fax: 630 953-9938

WEI Job No.: 201-34-01
Client: McDonough Associates, Inc.
Project: I-55 Interchange at Arsenal Road
Location: T34, R9E, Sec. 21, 22, 28, 27, Will Co., Illinois

Datum: NAVD
Elevation: 541.88 ft
North: 1726178.41 ft
East: 1022731.85 ft
Station: 921+63.14
Offset: 26.48 LT

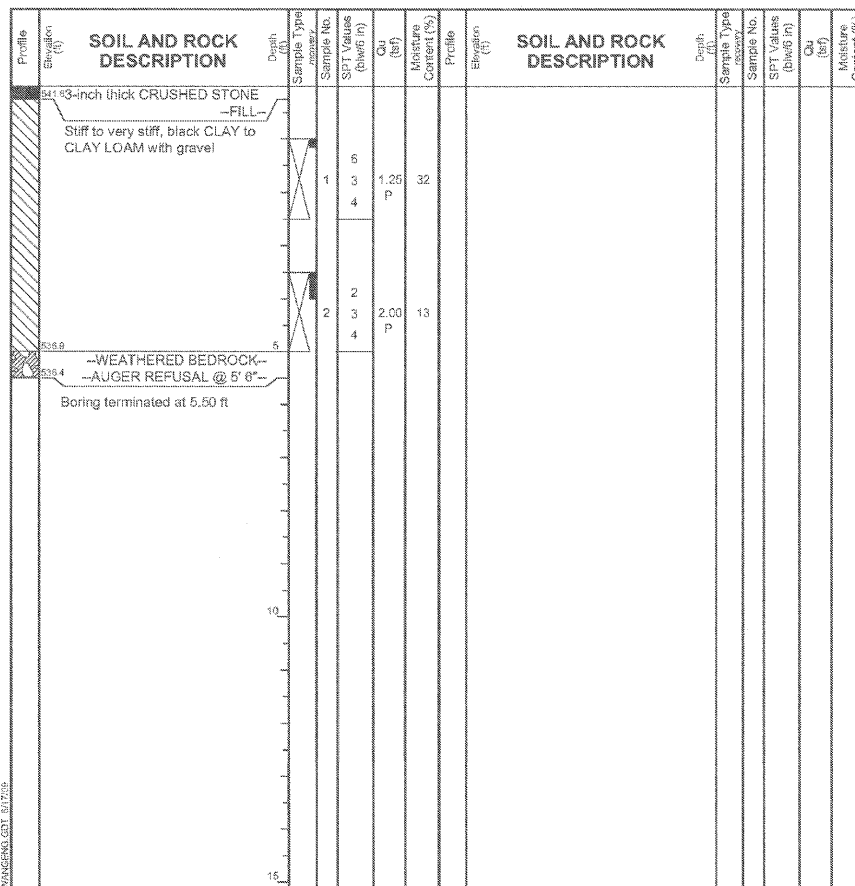

GENERAL NOTES		WATER LEVEL DATA	
Begin Drilling	08-20-2008	Complete Drilling	08-20-2008
Drilling Contractor	Wang Testing Service	Drill Rig	Mobile B-57 TMR
Driller	K & J	Logger	E. Datz
Checked by	E. Datz	Depth to Water	NA
Drilling Method	3.25" IDA HSA; Boring backfilled with bentonite upon completion	At Completion of Drilling	DRY
		Time After Drilling	NA
		Drilling Method	3.25" IDA HSA; Boring backfilled with bentonite upon completion

BORING LOG RWN-18 Page 1 of 1

Wang Engineering, Inc.
wangeng@wangeng.com
1145 Main Street
Lombard, IL 60148
Telephone: 630 953-9928
Fax: 630 953-9938

WEI Job No.: 201-34-01
Client: McDonough Associates, Inc.
Project: I-55 Interchange at Arsenal Road
Location: T34, R9E, Sec. 21, 22, 28, 27, Will Co., Illinois

Datum: NAVD
Elevation: 542.42 ft
North: 1726347.52 ft
East: 1022728.14 ft
Station: 923+32.21
Offset: 21.32 LT

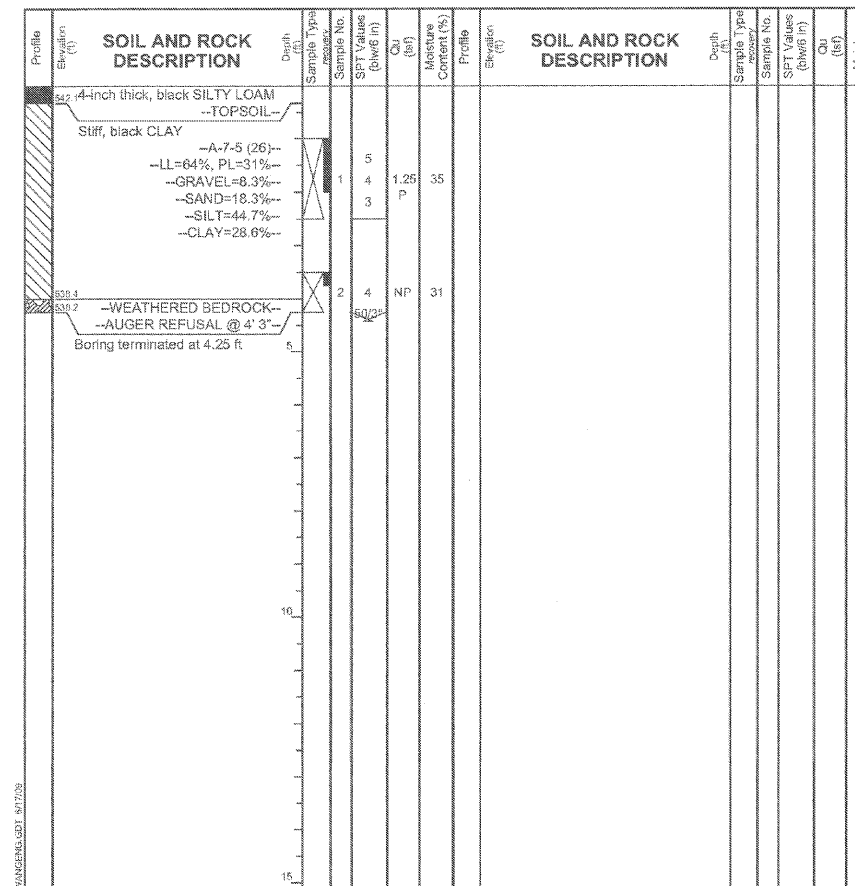

GENERAL NOTES		WATER LEVEL DATA	
Begin Drilling	08-20-2008	Complete Drilling	08-20-2008
Drilling Contractor	Wang Testing Service	Drill Rig	Mobile B-57 TMR
Driller	K & J	Logger	E. Datz
Checked by	E. Datz	Depth to Water	NA
Drilling Method	3.25" IDA HSA; Boring backfilled with bentonite upon completion	At Completion of Drilling	DRY
		Time After Drilling	NA
		Drilling Method	3.25" IDA HSA; Boring backfilled with bentonite upon completion

DESIGNED	PMH
CHECKED	MJL
DRAWN	PMH
CHECKED	MJL

SOIL BORINGS
STRUCTURE NO. 099-W027

McDonough Associates Inc.
Engineers / Architects
130 East Randolph Street
Chicago, Illinois 60601
(312) 946-8600

SHEET NO. RW2-25 SHEETS RW2-31	F.A.I. RTE.	SECTION	COUNTY	TOTAL SHEETS	SHEET NO.
	55	(99-1&2) R-6	WILL	756	489
FED. ROAD DIST. NO.			ILLINOIS FED. AID PROJECT		

CONTRACT NO. 60F12

STATE OF ILLINOIS
DEPARTMENT OF TRANSPORTATION

BORING LOG RWN-19
WEI Job No.: 201-34-01
Client: McDonough Associates, Inc.
Project: I-55 Interchange at Arsenal Road
Location: T34, R9E, Sec. 21, 22, 28, 27, Will Co., Illinois

Datum: NAVD
Elevation: 543.05 ft
North: 1726497.37 ft
East: 1022724.24 ft
Station: 924+82.08
Offset: 21.41 LT

Profile Elevation (ft)	SOIL AND ROCK DESCRIPTION	Depth (ft)	Sample No.	SPT Values (blows/ft)	Qu (tsf)	Moisture Content (%)	Profile Elevation (ft)	SOIL AND ROCK DESCRIPTION	Depth (ft)	Sample No.	SPT Values (blows/ft)	Qu (tsf)	Moisture Content (%)
542.0	33-inch thick, black SILTY LOAM --TOPSOIL-- Medium stiff, brown and black SANDY CLAY LOAM with gravel	0	1	2 3 13	0.75	27	543.0		0				
540.0	Very dense, gray DOLOSTONE rock fragments --WEATHERED BEDROCK-- --AUGER REFUSAL @ 4"-- Boring terminated at 4.00 ft	4	2	50	NP	6	538.0		4				

GENERAL NOTES	WATER LEVEL DATA
Begin Drilling: 08-27-2008 Complete Drilling: 08-27-2008 Drilling Contractor: Wang Testing Service Drill Rig: Mobile B-57 TMR Driller: K & J Logger: F. Bozga Checked by: E. Datz Drilling Method: 3.25" IDA HSA; Boring backfilled with bentonite upon completion	While Drilling: DRY At Completion of Drilling: DRY Time After Drilling: NA Depth to Water: NA The stratification lines represent the approximate boundary between soil types; the actual transition may be gradual.

BORING LOG RWN-20
WEI Job No.: 201-34-01
Client: McDonough Associates, Inc.
Project: I-55 Interchange at Arsenal Road
Location: T34, R9E, Sec. 21, 22, 28, 27, Will Co., Illinois

Datum: NAVD
Elevation: 543.62 ft
North: 1726844.23 ft
East: 1022719.93 ft
Station: 926+28.99
Offset: 21.27 LT

Profile Elevation (ft)	SOIL AND ROCK DESCRIPTION	Depth (ft)	Sample No.	SPT Values (blows/ft)	Qu (tsf)	Moisture Content (%)	Profile Elevation (ft)	SOIL AND ROCK DESCRIPTION	Depth (ft)	Sample No.	SPT Values (blows/ft)	Qu (tsf)	Moisture Content (%)
543.0	33-inch thick, black SILTY LOAM --TOPSOIL-- Loose, brown and black SANDY LOAM, with gravel	0	1	3 3 4	NP	24	543.0		0				
540.0	Very dense, brown SAND and dolostone rock fragments --WEATHERED BEDROCK-- --AUGER REFUSAL @ 4"-- Boring terminated at 4.00 ft	4	2	17	NP	17	538.0		4				

GENERAL NOTES	WATER LEVEL DATA
Begin Drilling: 08-27-2008 Complete Drilling: 08-27-2008 Drilling Contractor: Wang Testing Service Drill Rig: Mobile B-57 TMR Driller: K & J Logger: F. Bozga Checked by: E. Datz Drilling Method: 3.25" IDA HSA; Boring backfilled with bentonite upon completion	While Drilling: DRY At Completion of Drilling: DRY Time After Drilling: NA Depth to Water: NA The stratification lines represent the approximate boundary between soil types; the actual transition may be gradual.

BORING LOG RWN-21
WEI Job No.: 201-34-01
Client: McDonough Associates, Inc.
Project: I-55 Interchange at Arsenal Road
Location: T34, R9E, Sec. 21, 22, 28, 27, Will Co., Illinois

Datum: NAVD
Elevation: 543.43 ft
North: 1726798.04 ft
East: 1022716.27 ft
Station: 927+82.87
Offset: 21.35 LT

Profile Elevation (ft)	SOIL AND ROCK DESCRIPTION	Depth (ft)	Sample No.	SPT Values (blows/ft)	Qu (tsf)	Moisture Content (%)	Profile Elevation (ft)	SOIL AND ROCK DESCRIPTION	Depth (ft)	Sample No.	SPT Values (blows/ft)	Qu (tsf)	Moisture Content (%)
543.0	33-inch thick GRAVELLY SAND --FILL-- Stiff, brown and black CLAY LOAM	0	1	5 4 4	1.75	46	543.0		0				
540.0	Very dense, gray DOLOSTONE rock fragments --WEATHERED BEDROCK-- --AUGER REFUSAL @ 4' 1"-- Boring terminated at 4.08 ft	4	2	23	NP	3	538.4		4				

GENERAL NOTES	WATER LEVEL DATA
Begin Drilling: 08-27-2008 Complete Drilling: 08-27-2008 Drilling Contractor: Wang Testing Service Drill Rig: Mobile B-57 TMR Driller: K & J Logger: F. Bozga Checked by: E. Datz Drilling Method: 3.25" IDA HSA; Boring backfilled with bentonite upon completion	While Drilling: DRY At Completion of Drilling: DRY Time After Drilling: NA Depth to Water: NA The stratification lines represent the approximate boundary between soil types; the actual transition may be gradual.

DESIGNED	PMH
CHECKED	MJL
DRAWN	PMH
CHECKED	MJL

**SOIL BORINGS
STRUCTURE NO. 099-W027**

McDonough Associates Inc.
Engineers / Architects
130 East Randolph Street
Chicago, Illinois 60601
(312) 946-8600

SHEET NO. RW2-26 SHEETS RW2-31	F.A.I. RTE.	SECTION	COUNTY	TOTAL SHEETS	SHEET NO.
	55	(99-1&2) R-6	WILL	756	490
FED. ROAD DIST. NO.			ILLINOIS FED. AID PROJECT		
CONTRACT NO. 60F12					

STATE OF ILLINOIS
DEPARTMENT OF TRANSPORTATION

BORING LOG RWN-22 Page 1 of 1

Wang Engineering, Inc.
Computing Geotechnical and
Environmental Engineers
wangeng@wangeng.com
1145 Main Street
Lombard, IL 60148
Telephone: 630 953-9928
Fax: 630 953-9938

WEI Job No.: 201-34-01
Client: McDonough Associates, Inc.
Project: I-55 Interchange at Arsenal Road
Location: T34, R9E, Sec. 21, 22, 28, 27, Will Co., Illinois

Datum: NAVD
Elevation: 544.07 ft
North: 1726972.18 ft
East: 1022710.95 ft
Station: 929+57.04
Offset: 20.22 LT

Profile Elevation (ft)	SOIL AND ROCK DESCRIPTION	Depth (ft)	Sample No.	SPT Values (blows/ft)	Qu (tsf)	Moisture Content (%)	Profile Elevation (ft)	SOIL AND ROCK DESCRIPTION	Depth (ft)	Sample No.	SPT Values (blows/ft)	Qu (tsf)	Moisture Content (%)
543.1	12-inch thick, brown GRAVELLY SAND --FILL--												
541.1	Loose, brown and black SANDY LOAM	1	4	NP	9								
541.1	Very dense, brown SANDY LOAM with dolostone rock fragments	2	NP	3									
539.3	--WEATHERED BEDROCK-- --AUGER REFUSAL @ 4' 3"-- Boring terminated at 4.25 ft	5											

GENERAL NOTES		WATER LEVEL DATA	
Begin Drilling: 08-27-2008	Complete Drilling: 08-27-2008	While Drilling: <input checked="" type="checkbox"/> DRY	
Drilling Contractor: Wang Testing Service	Drill Rig: Mobile B-57 TMR	At Completion of Drilling: <input checked="" type="checkbox"/> DRY	
Driller: K & J	Logger: F. Bozga	Time After Drilling: NA	
Checked by: E. Datz		Depth to Water: <input checked="" type="checkbox"/> NA	
Drilling Method: 3.25" IDA HSA; Boring backfilled with bentonite upon completion		The stratification lines represent the approximate boundary between soil types; the actual transition may be gradual.	

BORING LOG RWN-23 Page 1 of 1

Wang Engineering, Inc.
Computing Geotechnical and
Environmental Engineers
wangeng@wangeng.com
1145 Main Street
Lombard, IL 60148
Telephone: 630 953-9928
Fax: 630 953-9938

WEI Job No.: 201-34-01
Client: McDonough Associates, Inc.
Project: I-55 Interchange at Arsenal Road
Location: T34, R9E, Sec. 21, 22, 28, 27, Will Co., Illinois

Datum: NAVD
Elevation: 544.08 ft
North: 1727111.74 ft
East: 1022708.08 ft
Station: 930+96.69
Offset: 21.71 LT

Profile Elevation (ft)	SOIL AND ROCK DESCRIPTION	Depth (ft)	Sample No.	SPT Values (blows/ft)	Qu (tsf)	Moisture Content (%)	Profile Elevation (ft)	SOIL AND ROCK DESCRIPTION	Depth (ft)	Sample No.	SPT Values (blows/ft)	Qu (tsf)	Moisture Content (%)
543.1	5-inch thick GRAVELLY SAND --SHOULDER COURSE--												
541.1	Stiff, brown CLAY LOAM with gravel --AUGER REFUSAL @ 4'0"--	1	5	2.25	10								
541.1		11											
541.1	Poor, highly weathered, light gray DOLOSTONE	2	NP	14									
535.1	--BEDROCK-- --RUN #1 (4' to 9')-- --REC=98%-- --RQD=43%-- --Qu=1121.0 tsf--	5											
535.1	Boring terminated at 9.00 ft	10											

GENERAL NOTES		WATER LEVEL DATA	
Begin Drilling: 08-18-2008	Complete Drilling: 08-18-2008	While Drilling: <input checked="" type="checkbox"/> DRY	
Drilling Contractor: Wang Testing Service	Drill Rig: Mobile B-57 TMR	At Completion of Drilling: <input checked="" type="checkbox"/> DRY	
Driller: K & J	Logger: E. Datz	Time After Drilling: NA	
Checked by: E. Datz		Depth to Water: <input checked="" type="checkbox"/> NA	
Drilling Method: 3.25" IDA HSA; Boring backfilled with bentonite upon completion		The stratification lines represent the approximate boundary between soil types; the actual transition may be gradual.	

BORING LOG RWN-24 Page 1 of 1

Wang Engineering, Inc.
Computing Geotechnical and
Environmental Engineers
wangeng@wangeng.com
1145 Main Street
Lombard, IL 60148
Telephone: 630 953-9928
Fax: 630 953-9938

WEI Job No.: 201-34-01
Client: McDonough Associates, Inc.
Project: I-55 Interchange at Arsenal Road
Location: T34, R9E, Sec. 21, 22, 28, 27, Will Co., Illinois

Datum: NAVD
Elevation: 544.51 ft
North: 1727256.40 ft
East: 1022702.75 ft
Station: 932+41.38
Offset: 20.6 LT

Profile Elevation (ft)	SOIL AND ROCK DESCRIPTION	Depth (ft)	Sample No.	SPT Values (blows/ft)	Qu (tsf)	Moisture Content (%)	Profile Elevation (ft)	SOIL AND ROCK DESCRIPTION	Depth (ft)	Sample No.	SPT Values (blows/ft)	Qu (tsf)	Moisture Content (%)
543.5	12-inch thick, brown GRAVELLY SAND --FILL--												
541.5	Very stiff, brown and black CLAY LOAM --GRAVEL=13.5%-- --SAND=20.5%-- --SILT=42.2%-- --CLAY=23.9%--	1	5	2.25	26								
541.5		3											
541.5	Very dense, brown SANDY LOAM with dolostone rock fragments	5											
539.5	--WEATHERED BEDROCK-- --AUGER REFUSAL @ 4' 6"-- Boring terminated at 4.50 ft	2	8	NP	8								

GENERAL NOTES		WATER LEVEL DATA	
Begin Drilling: 08-27-2008	Complete Drilling: 08-27-2008	While Drilling: <input checked="" type="checkbox"/> DRY	
Drilling Contractor: Wang Testing Service	Drill Rig: Mobile B-57 TMR	At Completion of Drilling: <input checked="" type="checkbox"/> DRY	
Driller: K & J	Logger: F. Bozga	Time After Drilling: NA	
Checked by: E. Datz		Depth to Water: <input checked="" type="checkbox"/> NA	
Drilling Method: 3.25" IDA HSA; Boring backfilled with bentonite upon completion		The stratification lines represent the approximate boundary between soil types; the actual transition may be gradual.	

DESIGNED	PMH
CHECKED	MJL
DRAWN	PMH
CHECKED	MJL

**SOIL BORINGS
STRUCTURE NO. 099-W027**

McDonough Associates Inc.
Engineers / Architects
130 East Randolph Street
Chicago, Illinois 60601
(312) 946-8600

SHEET NO. RW2-27 SHEETS RW2-31	F.A.I. RTE.	SECTION	COUNTY	TOTAL SHEETS	SHEET NO.
	55	(99-1&2) R-6	WILL	756	491
CONTRACT NO. 60F12					
FED. ROAD DIST. NO. ILLINOIS FED. AID PROJECT					

STATE OF ILLINOIS
DEPARTMENT OF TRANSPORTATION

BORING LOG RWN-25
WEI Job No.: 201-34-01
Client: McDonough Associates, Inc.
Project: I-55 Interchange at Arsenal Road
Location: T34, R9E, Sec. 21, 22, 28, 27, Will Co., Illinois

Datum: NAVD
Elevation: 545.16 ft
North: 1727397.44 ft
East: 1022695.83 ft
Station: 933+82.51
Offset: 21.12 LT

Profile Elevation (ft)	SOIL AND ROCK DESCRIPTION	Depth (ft)	Sample No.	SPT Values (blows/in)	Qu (tsf)	Moisture Content (%)	Profile Elevation (ft)	SOIL AND ROCK DESCRIPTION	Depth (ft)	Sample No.	SPT Values (blows/in)	Qu (tsf)	Moisture Content (%)
544.2	12-inch thick, brown GRAVELLY SAND												
	--FILL--												
	Stiff, brown and black SANDY CLAY LOAM	4	1	6	1.25	27							
		6											
542.7	Dense, brown SANDY LOAM with dolostone rock fragments												
	--WEATHERED BEDROCK--												
	--AUGER REFUSAL @ 4' 6"--												
540.7	Boring terminated at 4.50 ft	5											

GENERAL NOTES
Begin Drilling: 08-27-2008
Complete Drilling: 08-27-2008
Drilling Contractor: Wang Testing Service
Drill Rig: Mobile B-57 TMR
Driller: K & J
Logger: F. Bozga
Checked by: E. Datz
Drilling Method: 3.25" IDA HSA; Boring backfilled with bentonite upon completion

WATER LEVEL DATA
While Drilling: DRY
At Completion of Drilling: DRY
Time After Drilling: NA
Depth to Water: NA
The stratification lines represent the approximate boundary between soil layers; the actual transition may be gradual.

BORING LOG RWN-26
WEI Job No.: 201-34-01
Client: McDonough Associates, Inc.
Project: I-55 Interchange at Arsenal Road
Location: T34, R9E, Sec. 21, 22, 28, 27, Will Co., Illinois

Datum: NAVD
Elevation: 548.26 ft
North: 1727545.05 ft
East: 1022695.85 ft
Station: 935+30.15
Offset: 20.93 LT

Profile Elevation (ft)	SOIL AND ROCK DESCRIPTION	Depth (ft)	Sample No.	SPT Values (blows/in)	Qu (tsf)	Moisture Content (%)	Profile Elevation (ft)	SOIL AND ROCK DESCRIPTION	Depth (ft)	Sample No.	SPT Values (blows/in)	Qu (tsf)	Moisture Content (%)
	12-inch thick, black and brown SANDY LOAM												
	--TOPSOIL--												
545.2	Loose to medium dense, brown Gravelly LOAM												
	--GRAVEL=66.9%--												
	--SAND=13.8%--												
	--SILT=14.3%--												
	--CLAY=5.0%--												
		8											
		1	5	NP	17								
		4											
		3											
		2											
541.8	--WEATHERED BEDROCK--												
	--AUGER REFUSAL @ 5' 6"--												
547.9	Boring terminated at 5.50 ft	5											

GENERAL NOTES
Begin Drilling: 08-27-2008
Complete Drilling: 08-27-2008
Drilling Contractor: Wang Testing Service
Drill Rig: Mobile B-57 TMR
Driller: K & J
Logger: F. Bozga
Checked by: E. Datz
Drilling Method: 3.25" IDA HSA; Boring backfilled with bentonite upon completion

WATER LEVEL DATA
While Drilling: DRY
At Completion of Drilling: DRY
Time After Drilling: NA
Depth to Water: NA
The stratification lines represent the approximate boundary between soil layers; the actual transition may be gradual.

BORING LOG RWN-27
WEI Job No.: 201-34-01
Client: McDonough Associates, Inc.
Project: I-55 Interchange at Arsenal Road
Location: T34, R9E, Sec. 21, 22, 28, 27, Will Co., Illinois

Datum: NAVD
Elevation: 548.37 ft
North: 1727695.65 ft
East: 1022690.76 ft
Station: 936+74.8
Offset: 21.79 LT

Profile Elevation (ft)	SOIL AND ROCK DESCRIPTION	Depth (ft)	Sample No.	SPT Values (blows/in)	Qu (tsf)	Moisture Content (%)	Profile Elevation (ft)	SOIL AND ROCK DESCRIPTION	Depth (ft)	Sample No.	SPT Values (blows/in)	Qu (tsf)	Moisture Content (%)
	12-inch thick, black and brown SANDY LOAM												
	--TOPSOIL--												
547.4	Medium dense, brown SANDY LOAM, trace gravel												
		7											
		8											
		6											
545.4	--WEATHERED BEDROCK--												
	--AUGER REFUSAL @ 3' 6"--												
544.9	Boring terminated at 3.59 ft	2											
		50/1"											

GENERAL NOTES
Begin Drilling: 08-27-2008
Complete Drilling: 08-27-2008
Drilling Contractor: Wang Testing Service
Drill Rig: Mobile B-57 TMR
Driller: K & J
Logger: F. Bozga
Checked by: E. Datz
Drilling Method: 3.25" IDA HSA; Boring backfilled with bentonite upon completion

WATER LEVEL DATA
While Drilling: DRY
At Completion of Drilling: DRY
Time After Drilling: NA
Depth to Water: NA
The stratification lines represent the approximate boundary between soil layers; the actual transition may be gradual.

DESIGNED	PMH
CHECKED	MJL
DRAWN	PMH
CHECKED	MJL

McDonough Associates Inc.
Engineers / Architects
130 East Randolph Street
Chicago, Illinois 60601
(312) 946-8600

SHEET NO. RW2-28 SHEETS RW2-31	F.A.I. RTE.	SECTION	COUNTY	TOTAL SHEETS	SHEET NO.
	55	(99-1&2) R-6	WILL	756	492
FED. ROAD DIST. NO.			ILLINOIS	FED. AID PROJECT	
CONTRACT NO. 60F12					

SOIL BORINGS
STRUCTURE NO. 099-W027

STATE OF ILLINOIS
DEPARTMENT OF TRANSPORTATION

BORING LOG RWN-31 Page 1 of 1
 WEI Job No.: 201-34-01
 Datum: NAVD
 Elevation: 555.28 ft
 North: 1728298.28 ft
 East: 1022672.68 ft
 Station: 042+83.72
 Offset: 23.42 LT
 Client: McDonough Associates, Inc.
 Project: I-55 Interchange at Arsenal Road
 Location: T34, R9E, Sec. 21, 22, 28, 27, Will Co., Illinois

Profile Elevation (ft)	SOIL AND ROCK DESCRIPTION	Depth (ft)	Sample No.	SPT Values (blows/ft)	Moisture Content (%)	Profile Elevation (ft)	SOIL AND ROCK DESCRIPTION	Depth (ft)	Sample No.	SPT Values (blows/ft)	Moisture Content (%)
555.28	3-inch thick, dark gray SILTY LOAM --TOPSOIL-- Medium dense, brown SAND and gravel	0-9	1	NP	5	555.28	3-inch thick, dark gray SILTY LOAM --TOPSOIL-- Medium dense, brown SAND and gravel	0-9	1	NP	5
549.5	Medium dense, brown GRAVELLY SAND with dolostone rock fragments --WEATHERED BEDROCK-- --AUGER REFUSAL @ 8"--	9-11	2	NP	5	549.5	Medium dense, brown GRAVELLY SAND with dolostone rock fragments --WEATHERED BEDROCK-- --AUGER REFUSAL @ 8"--	9-11	2	NP	5
547.3	Boring terminated at 8.00 ft	11-16	3	NP	4	547.3	Boring terminated at 8.00 ft	11-16	3	NP	4

GENERAL NOTES		WATER LEVEL DATA	
Begin Drilling	08-27-2008	Complete Drilling	08-27-2008
Drilling Contractor	Wang Testing Service	Drill Rig	Mobile B-57 TMR
Driller	K & J	Logger	F. Bozga
Checked by	E. Datz	Time After Drilling	NA
Drilling Method	3.25" IDA HSA; Boring backfilled with bentonite upon completion	Depth to Water	NA

BORING LOG RWN-32 Page 1 of 1
 WEI Job No.: 201-34-01
 Datum: NAVD
 Elevation: 554.45 ft
 North: 1728441.92 ft
 East: 1022668.80 ft
 Station: 944+27.42
 Offset: 23.23 LT
 Client: McDonough Associates, Inc.
 Project: I-55 Interchange at Arsenal Road
 Location: T34, R9E, Sec. 21, 22, 28, 27, Will Co., Illinois

Profile Elevation (ft)	SOIL AND ROCK DESCRIPTION	Depth (ft)	Sample No.	SPT Values (blows/ft)	Moisture Content (%)	Profile Elevation (ft)	SOIL AND ROCK DESCRIPTION	Depth (ft)	Sample No.	SPT Values (blows/ft)	Moisture Content (%)
554.45	3-inch thick, black SILTY LOAM --TOPSOIL-- Medium dense, brown SAND	0-10	1	NP	8	554.45	3-inch thick, black SILTY LOAM --TOPSOIL-- Medium dense, brown SAND	0-10	1	NP	8
550.5	Medium dense, brown SAND and dolostone rock fragments --WEATHERED BEDROCK-- --AUGER REFUSAL @ 5.5"--	10-15	2	NP	5	550.5	Medium dense, brown SAND and dolostone rock fragments --WEATHERED BEDROCK-- --AUGER REFUSAL @ 5.5"--	10-15	2	NP	5
549.0	Boring terminated at 5.50 ft	15-16	5	NP	5	549.0	Boring terminated at 5.50 ft	15-16	5	NP	5

GENERAL NOTES		WATER LEVEL DATA	
Begin Drilling	08-27-2008	Complete Drilling	08-27-2008
Drilling Contractor	Wang Testing Service	Drill Rig	Mobile B-57 TMR
Driller	K & J	Logger	F. Bozga
Checked by	E. Datz	Time After Drilling	NA
Drilling Method	3.25" IDA HSA; Boring backfilled with bentonite upon completion	Depth to Water	NA

BORING LOG RWN-33 Page 1 of 1
 WEI Job No.: 201-34-01
 Datum: NAVD
 Elevation: 553.88 ft
 North: 1728597.24 ft
 East: 1022660.72 ft
 Station: 945+81.2
 Offset: 25.3 LT
 Client: McDonough Associates, Inc.
 Project: I-55 Interchange at Arsenal Road
 Location: T34, R9E, Sec. 21, 22, 28, 27, Will Co., Illinois

Profile Elevation (ft)	SOIL AND ROCK DESCRIPTION	Depth (ft)	Sample No.	SPT Values (blows/ft)	Moisture Content (%)	Profile Elevation (ft)	SOIL AND ROCK DESCRIPTION	Depth (ft)	Sample No.	SPT Values (blows/ft)	Moisture Content (%)
553.88	6-inch thick, black SILTY LOAM --TOPSOIL-- Stiff, brown SILTY CLAY LOAM with gravel	0-5	1	NP	11	553.88	6-inch thick, black SILTY LOAM --TOPSOIL-- Stiff, brown SILTY CLAY LOAM with gravel	0-5	1	NP	11
552.3	Medium dense, brown SANDY LOAM with gravel	5-12	2	NP	11	552.3	Medium dense, brown SANDY LOAM with gravel	5-12	2	NP	11
550.5	Very stiff, brown CLAY with gravel	12-18	3	NP	18	550.5	Very stiff, brown CLAY with gravel	12-18	3	NP	18
549.0	Very dense, brown DOLOSTONE ROCK FRAGMENTS --WEATHERED BEDROCK-- --AUGER REFUSAL @ 4"--	18-20	4	NP	18	549.0	Very dense, brown DOLOSTONE ROCK FRAGMENTS --WEATHERED BEDROCK-- --AUGER REFUSAL @ 4"--	18-20	4	NP	18
547.3	Very poor, gray and white DOLOSTONE --BEDROCK-- --RUN #1 (4' to 9')-- --REC=90%-- --RQD=7%--	20-30	5	NP	18	547.3	Very poor, gray and white DOLOSTONE --BEDROCK-- --RUN #1 (4' to 9')-- --REC=90%-- --RQD=7%--	20-30	5	NP	18
514.8	Boring terminated at 9.00 ft	30-35	6	NP	18	514.8	Boring terminated at 9.00 ft	30-35	6	NP	18

GENERAL NOTES		WATER LEVEL DATA	
Begin Drilling	08-15-2008	Complete Drilling	08-15-2008
Drilling Contractor	Wang Testing Service	Drill Rig	Mobile B-57 TMR
Driller	K & J	Logger	R. Edelmann
Checked by	E. Datz	Time After Drilling	NA
Drilling Method	3.25" IDA HSA; Boring backfilled with bentonite upon completion	Depth to Water	NA

DESIGNED	PMH
CHECKED	MJL
DRAWN	PMH
CHECKED	MJL

SOIL BORINGS
STRUCTURE NO. 099-W027



McDonough Associates Inc.
Engineers / Architects
130 East Randolph Street
Chicago, Illinois 60601
(312) 946-8600

SHEET NO. RW2-30 SHEETS RW2-31	F.A.I. RTE.	SECTION	COUNTY	TOTAL SHEETS	SHEET NO.
	55	(99-1&2) R-6	WILL	756	494
CONTRACT NO. 60F12					
FED. ROAD DIST. NO.		ILLINOIS	FED. AID PROJECT		

STATE OF ILLINOIS
DEPARTMENT OF TRANSPORTATION

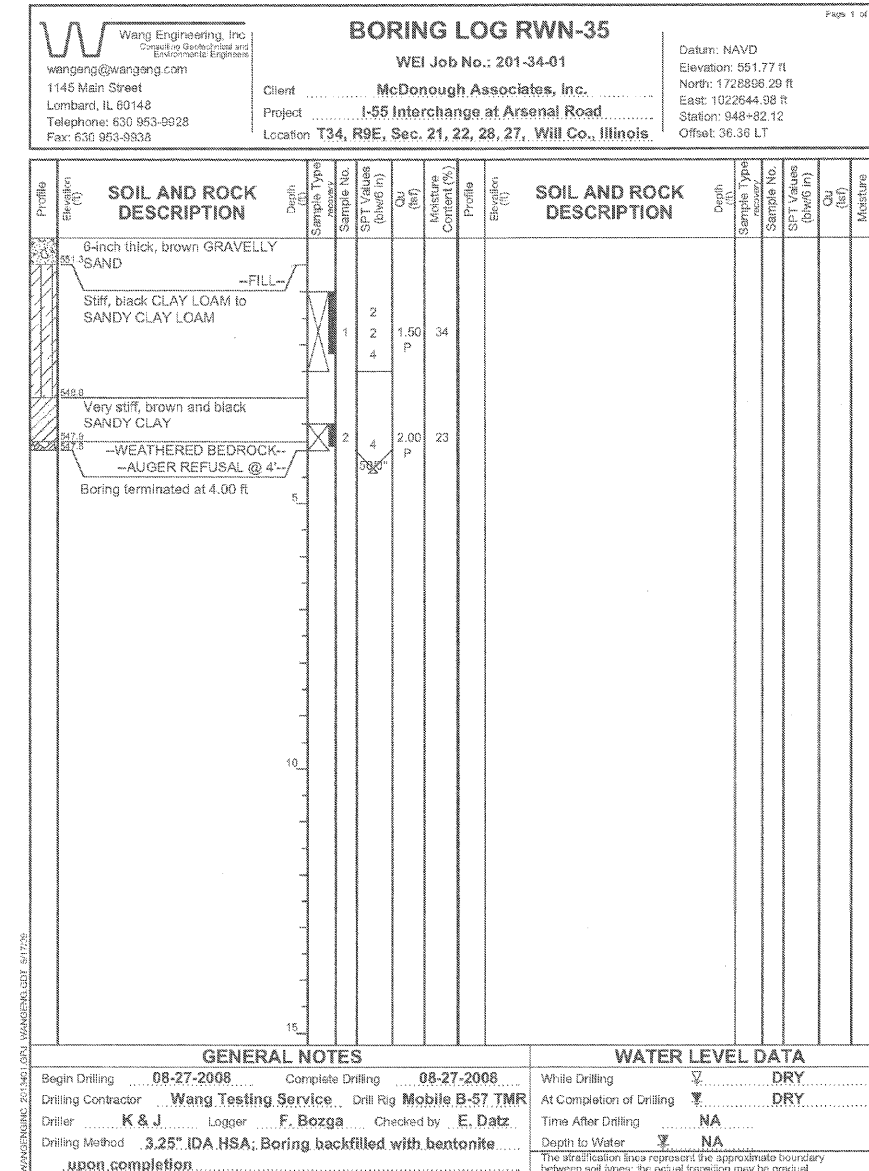
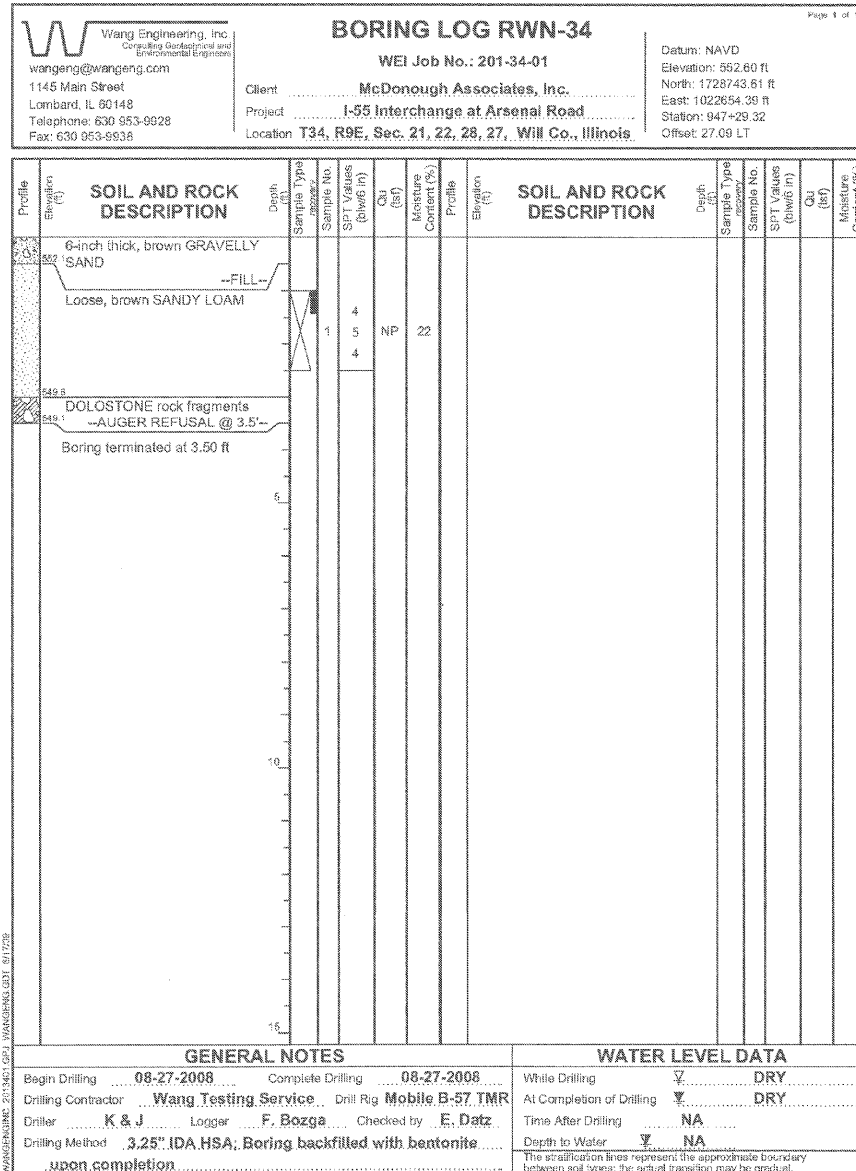

DESIGNED	PMH
CHECKED	MJL
DRAWN	PMH
CHECKED	MJL

SOIL BORINGS
STRUCTURE NO. 099-W027

McDonough Associates Inc.
Engineers / Architects
130 East Randolph Street
Chicago, Illinois 60601
(312) 946-8600

SHEET NO. RW2-31 SHEETS RW2-31	F.A.I. RTE.	SECTION	COUNTY	TOTAL SHEETS	SHEET NO.
	55	(99-1&2) R-6	WILL	756	495
CONTRACT NO. 60F12					
FED. ROAD DIST. NO.		ILLINOIS	FED. AID PROJECT		

STATE OF ILLINOIS
DEPARTMENT OF TRANSPORTATION

Bench Mark:
(BMRR) Box cut at top of S.E. wingwall of Grant Creek Bridge on E. Frontage Rd. of I-55, Elev. 520.80
Existing Structure:
None.

DESIGN STRESSES

FIELD UNITS

$f'_c = 3,500$ psi
 $f_y = 60,000$ psi (Reinforcement)

PRECAST UNITS

$f'_c = 4,500$ psi (pre-cast units)

DESIGN SPECIFICATIONS

2002 AASHTO Standard Specifications

CURVE DATA

Ramp C

PI STA. = 2037+82.40
 $\Delta = 132^\circ 56' 23.34"$ (LT)
 $D = 6^\circ 51' 42"$
 $R = 835.00'$
 $T = 1917.61'$
 $L = 1937.40'$
 $E = 1256.52'$
S.E. RUN = 0.06 Ft./Ft.
P.C. STA. = 2018+64.79
P.T. STA. = 2038+02.19

Full SE from Sta. 2019+76.79 to end of wall.
For transition of SE from Sta. 2019+76.79 to beginning of wall see Sheet RW3-2.

Only Parapet and Anchorage Slab are part of this Contract

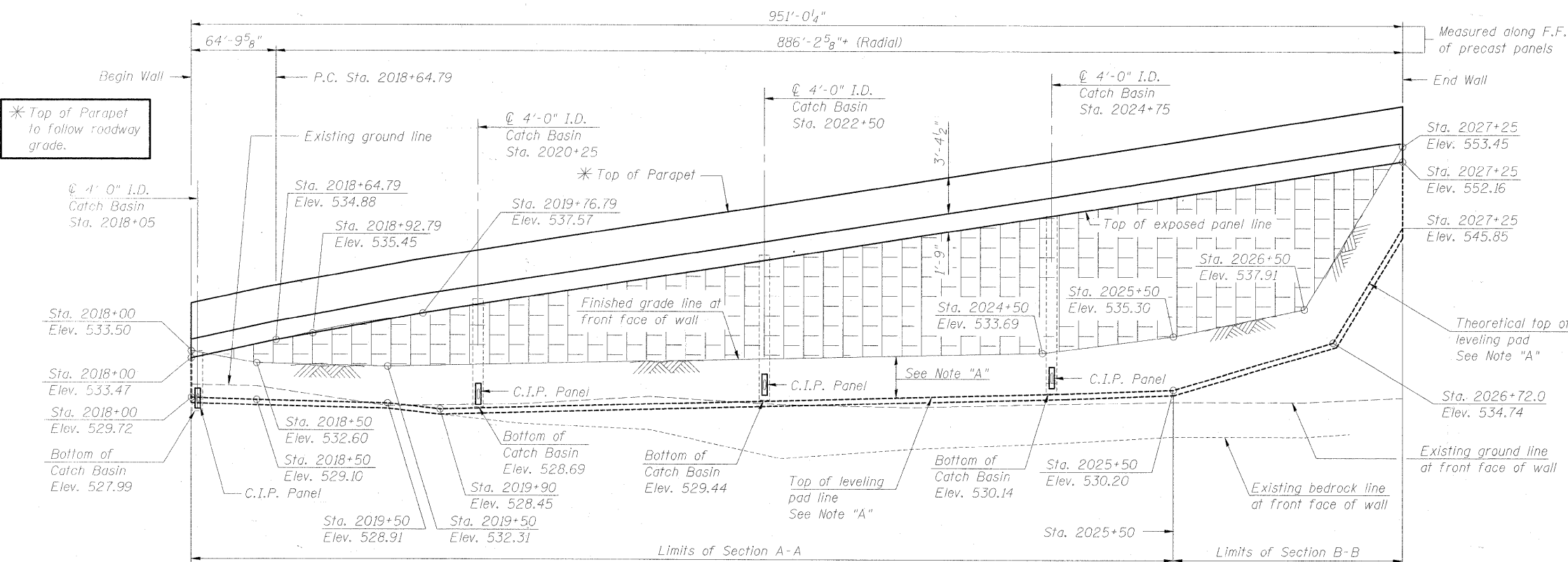

ELEVATION
(Looking at F.F. of wall)

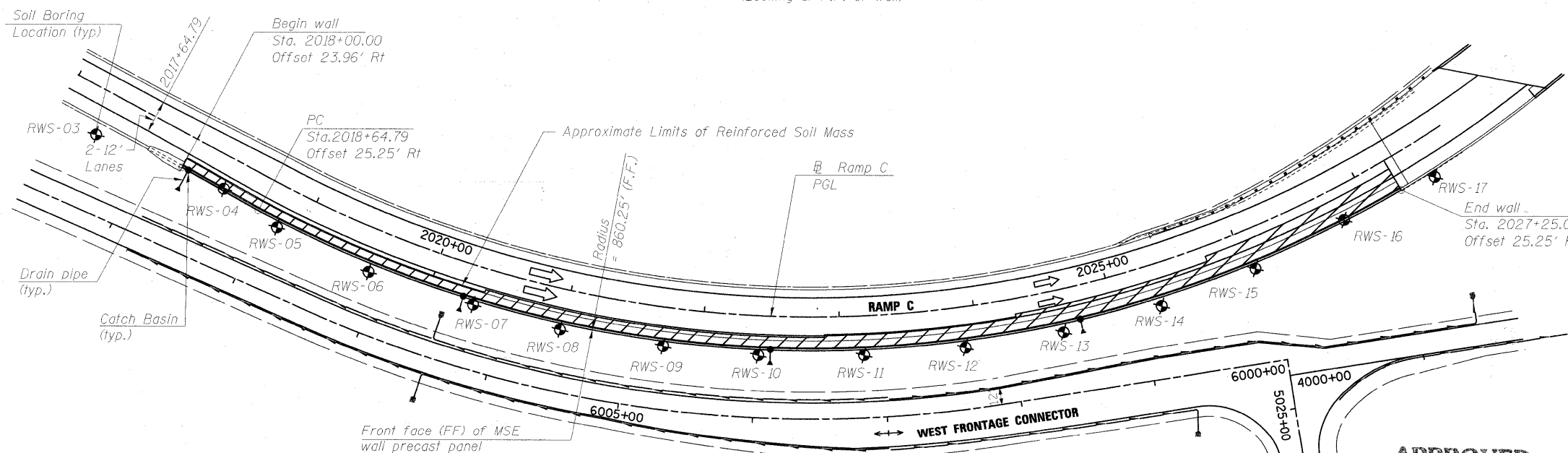

PLAN

Note:
Wall offsets are measured from the @ Ramp C to the front face of precast panels.

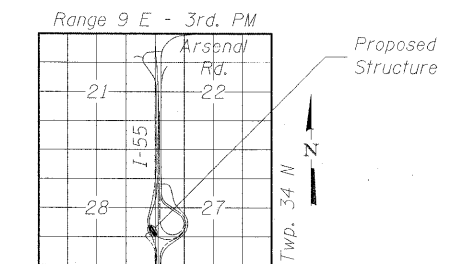

LOCATION SKETCH

DESIGNED	PMH
CHECKED	MJL
DRAWN	RJ
CHECKED	BKB

LEGEND

- ⊙ Manhole
- Catch Basin
- ⊕ Soil Boring
- F.F.=Front Face
- B.F.=Back Face
- E.F.=Each Face
- I.F.=Inside Face
- O.F.=Outside Face

APPROVED
FOR STRUCTURAL ADEQUACY ONLY
Gerald E. Koylass
ENGINEER OF BRIDGES AND STRUCTURES

SEAL
GERALD E. KOYLASS
091-005264
Exp: 11/30/2012

McDonough Associates Inc.
Engineers / Architects
130 East Randolph Street
Chicago, Illinois 60601
(312) 946-8600

SHEET NO. RW3-1 SHEETS RW3-7	F.A.I. RTE.	SECTION	COUNTY	TOTAL SHEETS	SHEET NO.
	55	(99-1&2) R-6	WILL	756	496
CONTRACT NO. 60F12					
FED. ROAD DIST. NO. 1 ILLINOIS FED. AID PROJECT					

GENERAL PLAN & ELEVATION
MSE WALL-RAMP C
F.A.I. RTE. 55 - SEC. (99-1&2) R-6
WILL COUNTY
STATION 2018+00 TO 2027+25
STRUCTURE NO. 099-W028

STATE OF ILLINOIS
DEPARTMENT OF TRANSPORTATION

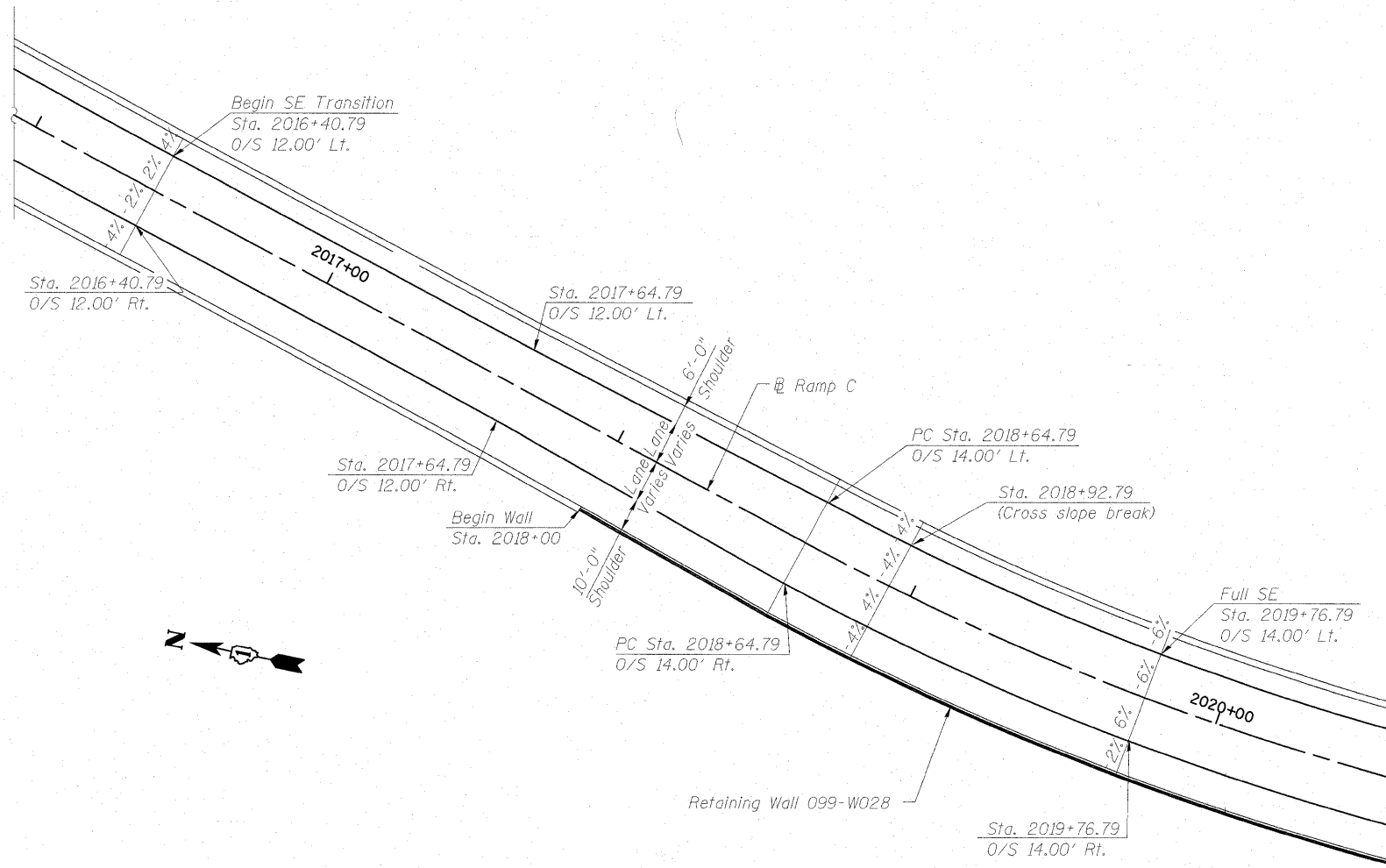

TRANSITION PLAN

INDEX OF SHEETS

1. General Plan & Elevation
2. General Details & Bill of Material
3. MSE Wall- Plan & Elevation
4. MSE Wall- Plan & Elevation
5. MSE Wall- Plan & Elevation
6. Sections and Details
7. Sections and Details

GENERAL NOTES

1. Reinforcement bars shall conform to the requirements of ASTM A 706 Gr 60. See Special Provisions.
2. Reinforcement bars designated (E) shall be epoxy coated.
3. Place the top most layer of soil reinforcement 3 feet below the gutter line elevation.
4. Verify all drainage information regarding catch basins, manholes & pipes from drainage plans prior to fabrication or construction.

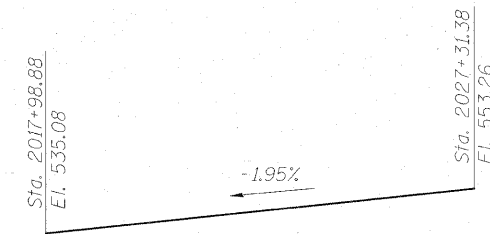

PROFILE GRADE - RAMP C

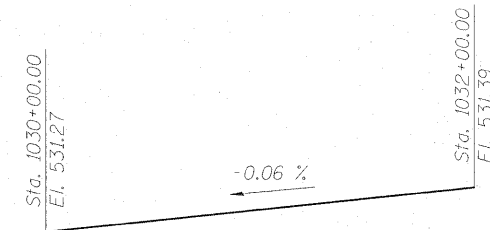

PROFILE GRADE - NB & SB I-55

TOTAL BILL OF MATERIAL

ITEM	UNIT	TOTAL
Concrete Structures	Cu. Yd.	473.9
Reinforcement Bars, Epoxy Coated	Pound	64,430

DESIGNED	PMH
CHECKED	MJL
DRAWN	RJ
CHECKED	BKB

**GENERAL DETAILS & BILL OF MATERIAL
STRUCTURE NO. 099-W028**

McDonough Associates Inc.
Engineers / Architects
130 East Randolph Street
Chicago, Illinois 60601
(312) 946-8600

SHEET NO. RW3-2 SHEETS RW3-7	F.A.I. RTE.	SECTION	COUNTY	TOTAL SHEETS	SHEET NO.
	55	(99-1&2) R-6	WILL	756	497
FED. ROAD DIST. NO.			ILLINOIS FED. AID PROJECT		
CONTRACT NO. 60F12					

STATE OF ILLINOIS
DEPARTMENT OF TRANSPORTATION

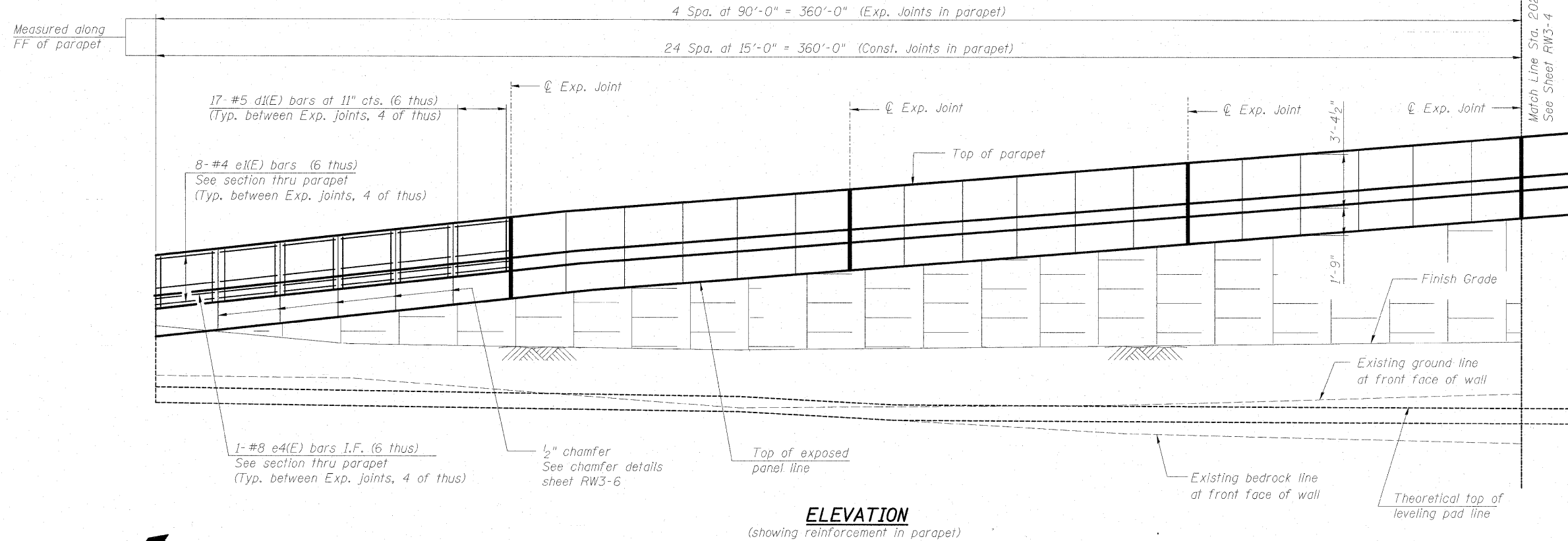

Note:
Slip forming of the parapet is not allowed.

Notes:
Parapet offsets are measured from the @ Ramp C to the front face of parapet.
For locations and sizes of manholes and pipes see drainage and utility plans.
Work this sheet with sheets RW3-1 & RW3-4.
For Bill of Material see sheet RW3-7.

Only Parapet and Anchorage Slab are part of this Contract

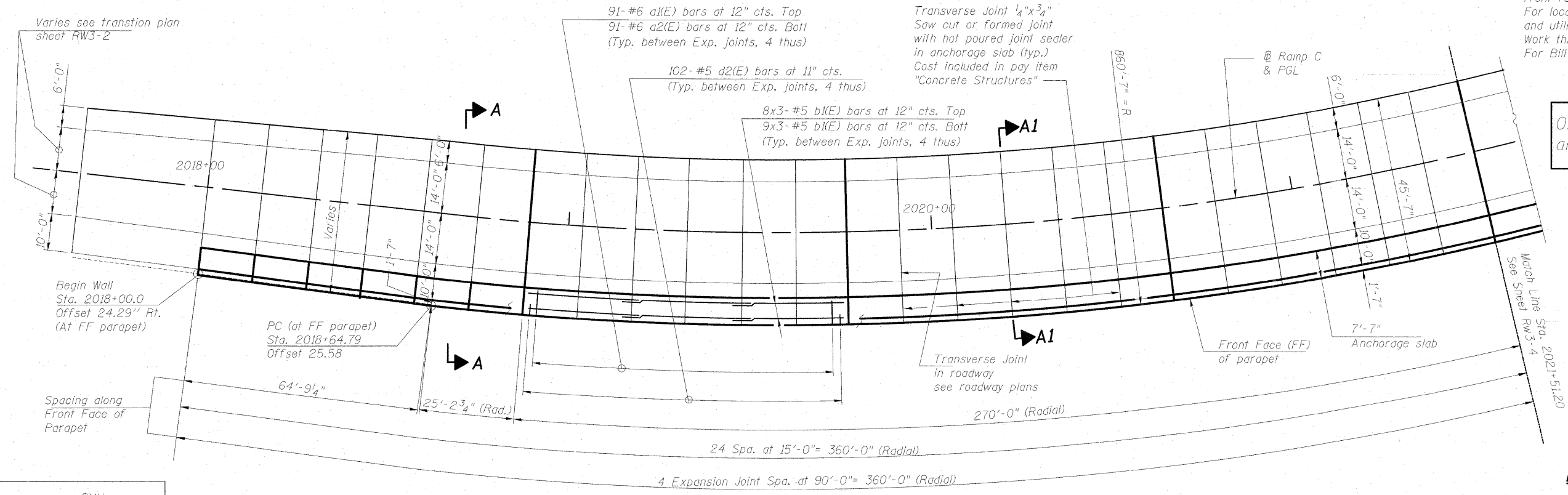

DESIGNED	PMH
CHECKED	MJL
DRAWN	RJ
CHECKED	BKB

MIN. LAP
#4 bar = 1'-4"
#5 bar = 1'-8"
#8 bar = 3'-8"

McDonough Associates Inc.
Engineers / Architects
130 East Randolph Street
Chicago, Illinois 60601
(312) 946-8600

SHEET NO. RW3-3 SHEETS RW3-7	F.A.I. RTE.	SECTION	COUNTY	TOTAL SHEETS	SHEET NO.
	55	(99-1&2) R-6	WILL	756	498
			CONTRACT NO. 60F12		
FED. ROAD DIST. NO.		ILLINOIS FED. AID PROJECT			

**MSE WALL- PLAN & ELEVATION
STRUCTURE NO. 099-W028**

STATE OF ILLINOIS
DEPARTMENT OF TRANSPORTATION

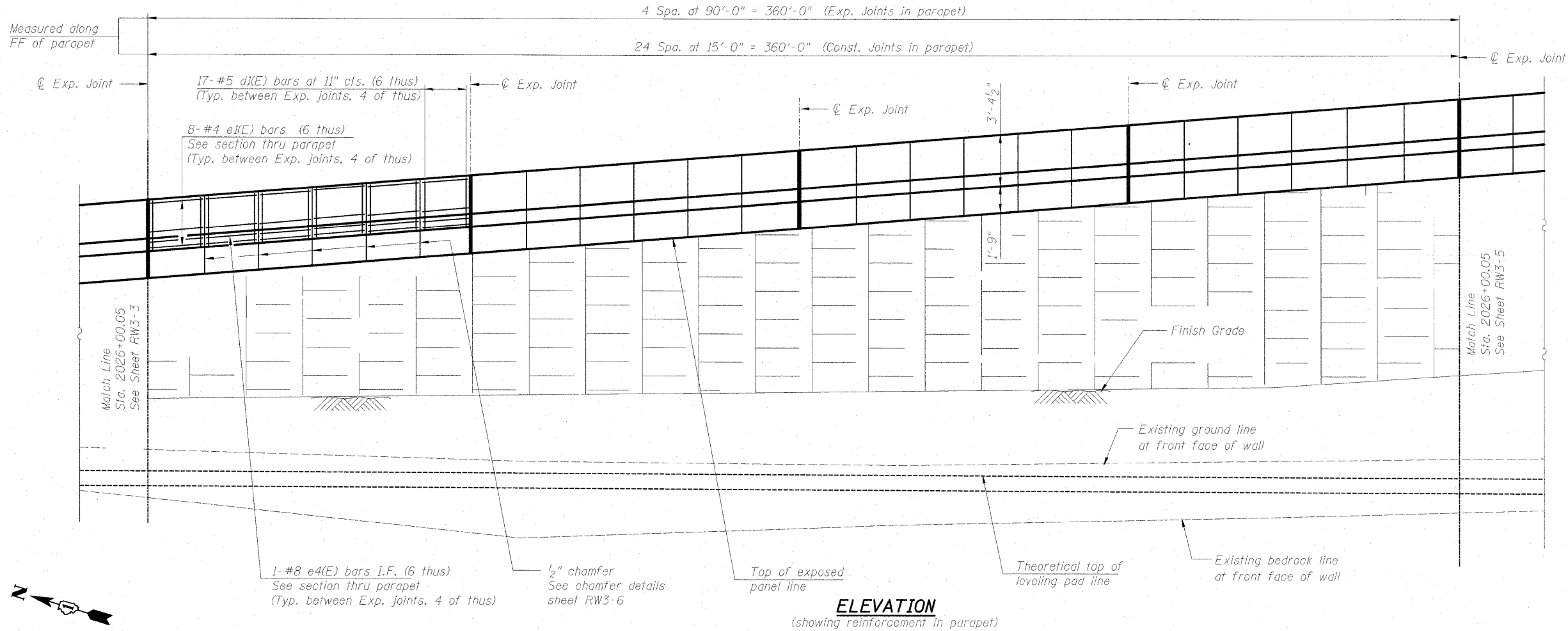

Note:
Slip forming of the parapet is not allowed.

Note:
Work this sheet with sheets RW3-1, RW3-3 & RW3-5.

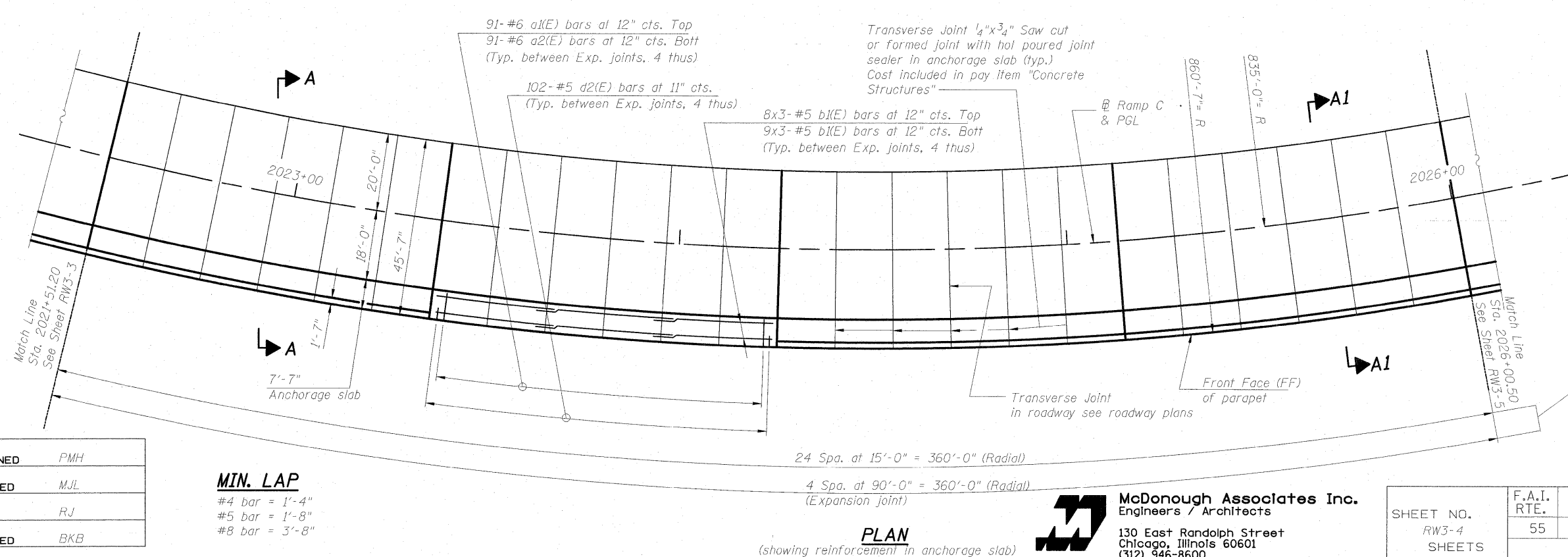

Only Parapet and Anchorage Slab are part of this Contract

DESIGNED	PMH
CHECKED	MJL
DRAWN	RJ
CHECKED	BKB

MIN. LAP
#4 bar = 1'-4"
#5 bar = 1'-8"
#8 bar = 3'-8"

McDonough Associates Inc.
Engineers / Architects
130 East Randolph Street
Chicago, Illinois 60601
(312) 946-8600

SHEET NO. RW3-4 SHEETS RW3-7	F.A.I. RTE.	SECTION	COUNTY	TOTAL SHEETS	SHEET NO.
	55	(99-1&2) R-6	WILL	756	499
CONTRACT NO. 60F12					
FED. ROAD DIST. NO.		ILLINOIS FED. AID PROJECT			

**MSE WALL - PLAN & ELEVATION
STRUCTURE NO. 099-W028**

STATE OF ILLINOIS
DEPARTMENT OF TRANSPORTATION

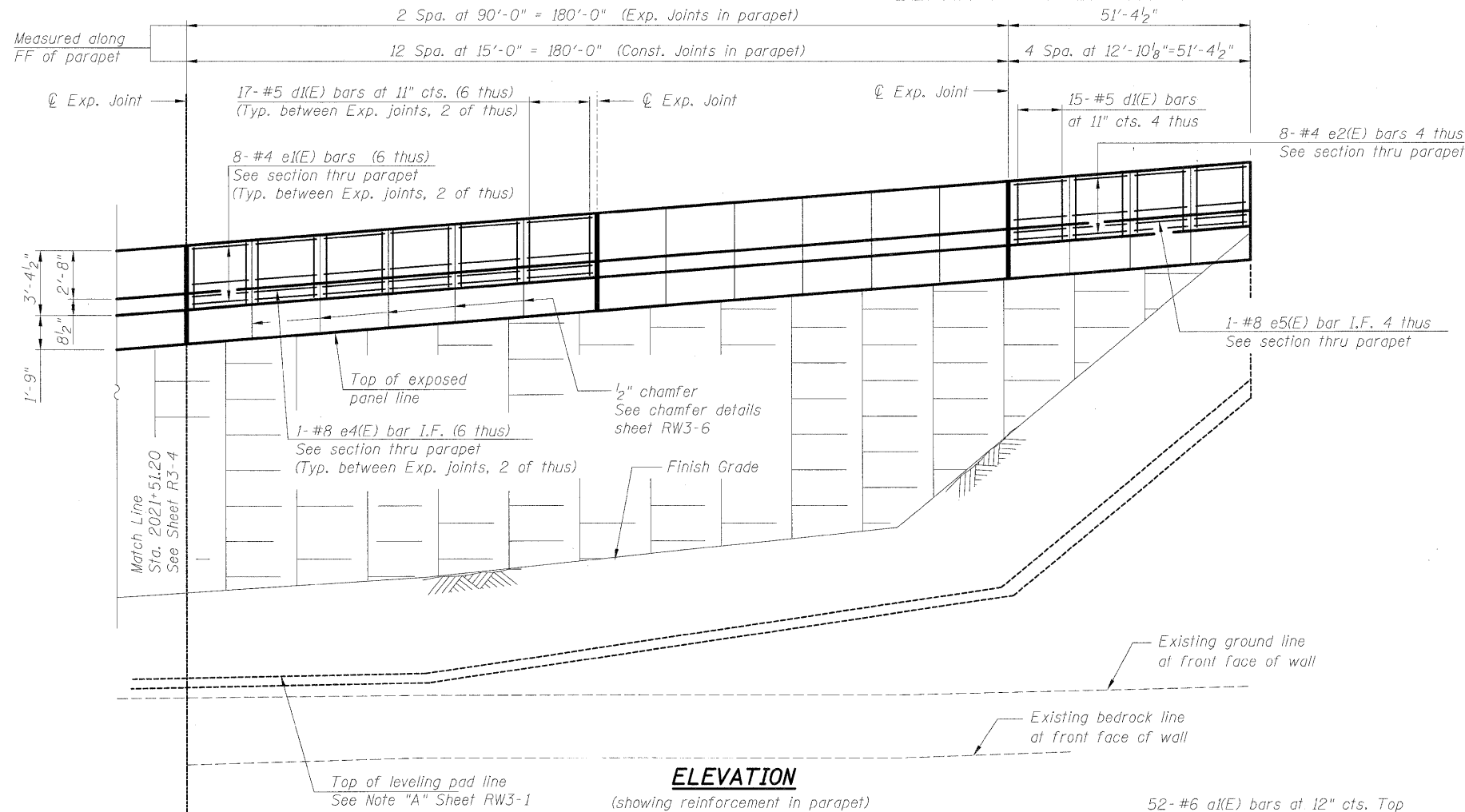

ELEVATION

(showing reinforcement in parapet)

Transverse Joint $\frac{1}{4} \times \frac{3}{4}$ " Saw cut or formed joint with hot poured joint sealer in anchorage slab (typ.)
Cost included in pay item "Concrete Structures"

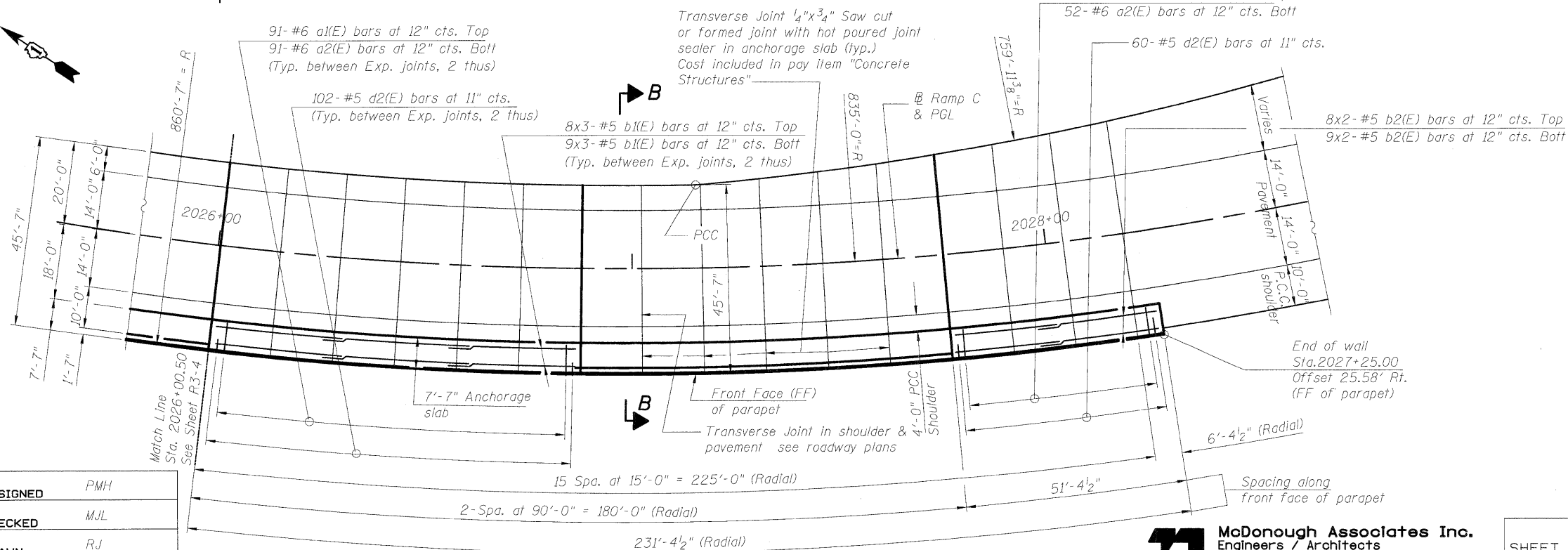

PLAN

(showing reinforcement in anchorage slab)

Only Parapet and Anchorage Slab are part of this Contract

Note:
Slip forming of the parapet is not allowed.

Note:
Work this sheet with sheets RW3-1 thru RW3-4.

DESIGNED	PMH
CHECKED	M.J.L.
DRAWN	RJ
CHECKED	BKB

McDonough Associates Inc.
Engineers / Architects
130 East Randolph Street
Chicago, Illinois 60601
(312) 946-8600

MSE WALL - PLAN & ELEVATION
STRUCTURE NO. 099-W028

SHEET NO.	F.A.I. RTE.	SECTION	COUNTY	TOTAL SHEETS	SHEET NO.
RW3-5	55	(99-1&2) AC-3	WILL	756	500
RW3-12					
CONTRACT NO. 60C31					
FED. ROAD DIST. NO. 1 ILLINOIS FED. AID PROJECT					