

**OPTION 1**

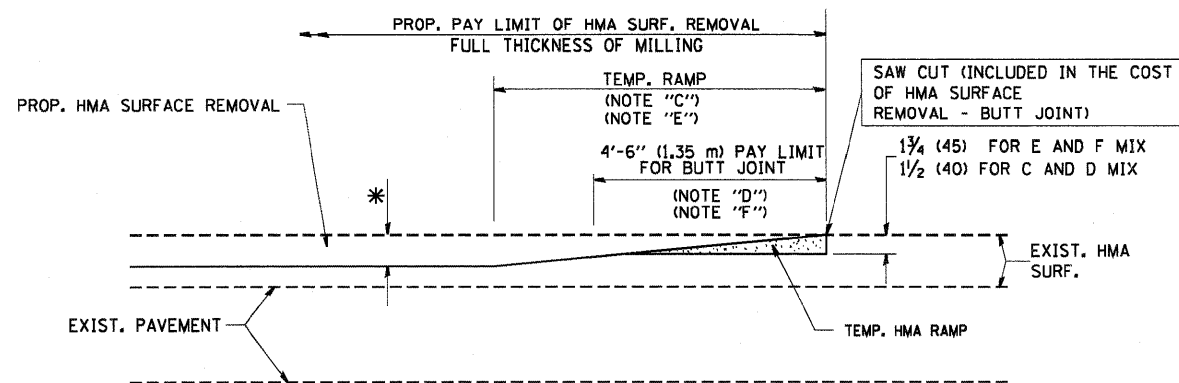

**OPTION 2  
TYPICAL TEMPORARY RAMP**

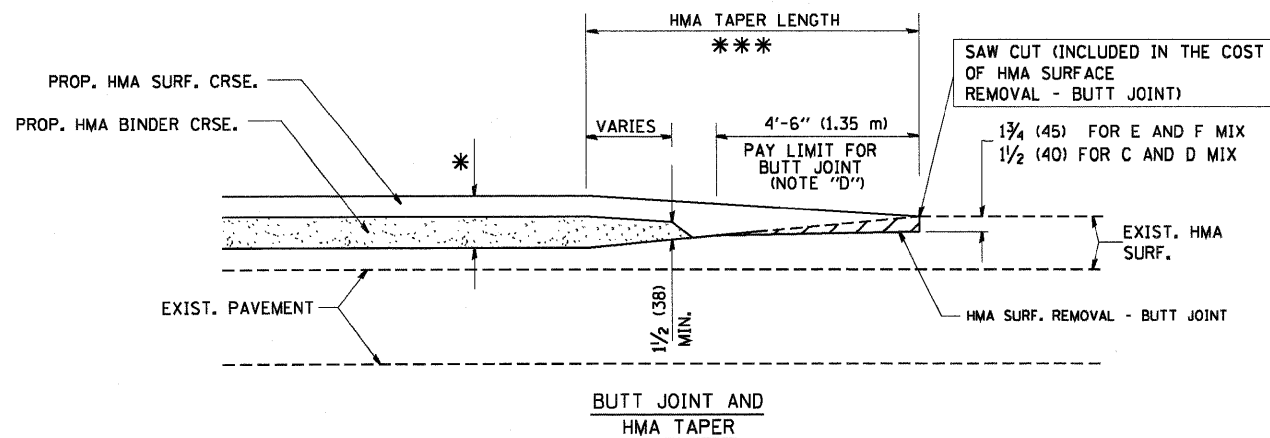

**TYPICAL BUTT JOINT AND HMA TAPER  
FOR MILLING AND RESURFACING**

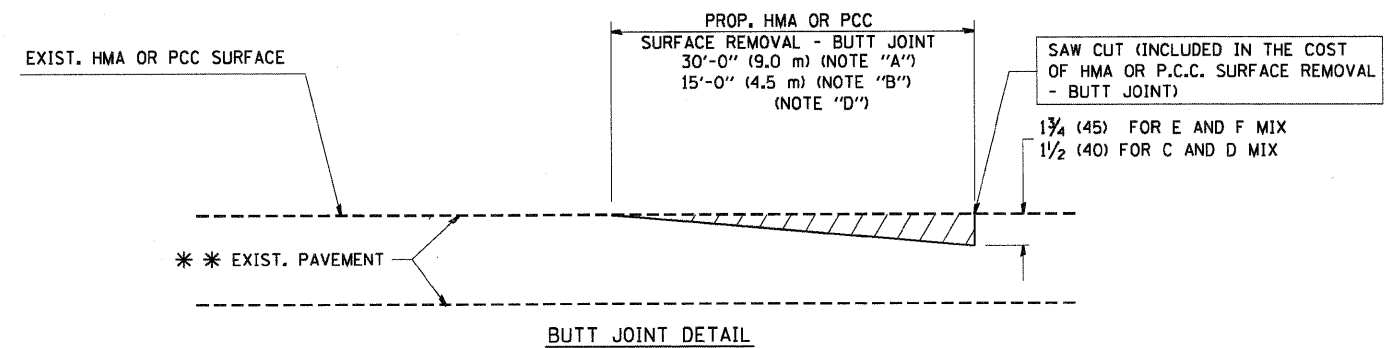

**BUTT JOINT DETAIL**

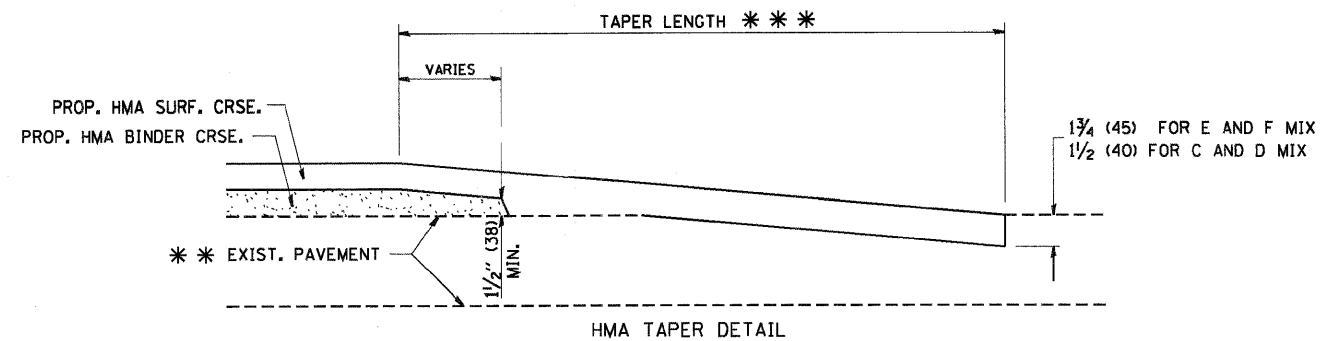

**HMA TAPER DETAIL**

**TYPICAL BUTT JOINT AND HMA TAPER  
FOR RESURFACING ONLY**

\*\*\* PC CONCRETE, HMA OR HMA RESURFACED PAVEMENT.

**NOTES**

- A: MAINLINE ROADWAYS AND MAJOR SIDE ROADS.
  - B: MINOR SIDE ROADS.
  - C: THE TEMP. RAMP SHALL BE CONSTRUCTED IMMEDIATELY UPON REMOVAL OF THE EXISTING HMA SURFACE.
  - D: THE BUTT JOINT SHALL BE CONSTRUCTED IMMEDIATELY PRIOR TO PLACING THE PROPOSED HMA COURSES.
  - E: TAPER THE TEMP. RAMP AT A RATE OF 3'-0" (900 mm) PER 1 INCH (25 mm) OF MILLING THICKNESS.
  - F: INSTALLATION AND REMOVAL OF THE 4'-6" (1.35 m) TEMP. RAMP IS INCLUDED IN COST OF HMA SURFACE REMOVAL - BUTT JOINT
  - G: SEE ARTICLE 406.08 AND 406.14 OF THE STANDARD SPECIFICATIONS FOR "HMA AND/OR PCC SURFACE REMOVAL, BUTT JOINT".
- \* SEE TYPICAL SECTIONS FOR MILLING THICKNESS.
- \*\*\* 20'-0" (6.1 m) PER 1 (25) RESURFACING (NOTE "A")  
10'-0" (3.0 m) PER 1 (25) RESURFACING (NOTE "B")

**BASIS OF PAYMENT:**

THE BUTT JOINT WILL BE PAID FOR AT THE CONTRACT UNIT PRICE PER SQUARE YARD (SQUARE METER) FOR "HOT-MIX ASPHALT SURFACE REMOVAL - BUTT JOINT" OR FOR "PORTLAND CEMENT CONCRETE SURFACE REMOVAL - BUTT JOINT".

ALL DIMENSIONS ARE IN INCHES (MILLIMETERS) UNLESS OTHERWISE SHOWN.

FILE NAME = F:\CBBEL\WEST Projects\2009\09-0147\_IL173\Civil\Drawings\Sheet\160123-9ht-01-16-032.dgn

FILE NAME =	USER NAME = gaglianobt
W:\d\stotd\22x34\bd32.dgn	
PLOT SCALE = 50.0000' / IN.	
PLOT DATE = 1/4/2008	

DESIGNED - M. DE YONG	REVISD - R. SHAH 10-25-94
DRAWN -	REVISD - A. ABBAS 03-21-97
CHECKED -	REVISD - M. GOMEZ 04-06-01
DATE - 06-13-90	REVISD - R. BORO 01-01-07

DESIGNED - M. DE YONG	REVISD - R. SHAH 10-25-94
DRAWN -	REVISD - A. ABBAS 03-21-97
CHECKED -	REVISD - M. GOMEZ 04-06-01
DATE - 06-13-90	REVISD - R. BORO 01-01-07

DESIGNED - M. DE YONG	REVISD - R. SHAH 10-25-94
DRAWN -	REVISD - A. ABBAS 03-21-97
CHECKED -	REVISD - M. GOMEZ 04-06-01
DATE - 06-13-90	REVISD - R. BORO 01-01-07

DESIGNED - M. DE YONG	REVISD - R. SHAH 10-25-94
DRAWN -	REVISD - A. ABBAS 03-21-97
CHECKED -	REVISD - M. GOMEZ 04-06-01
DATE - 06-13-90	REVISD - R. BORO 01-01-07

**STATE OF ILLINOIS  
DEPARTMENT OF TRANSPORTATION**

**BUTT JOINT AND  
HMA TAPER DETAILS**

SCALE: NONE SHEET NO. 1 OF 1 SHEETS STA. TO STA.

F.A.P. RTE.	SECTION	COUNTY	TOTAL SHEETS	SHEET NO.
303	132 B-2	McHENRY	106	83
BD400-05 BD32			CONTRACT NO. 60129	
FED. ROAD DIST. NO. 1 ILLINOIS FED. AID PROJECT				