

TYPICAL WING WALL SHEETING

(East Wing Walls Sheetting Shown, West Wing Walls Sheetting Opposite Hand)

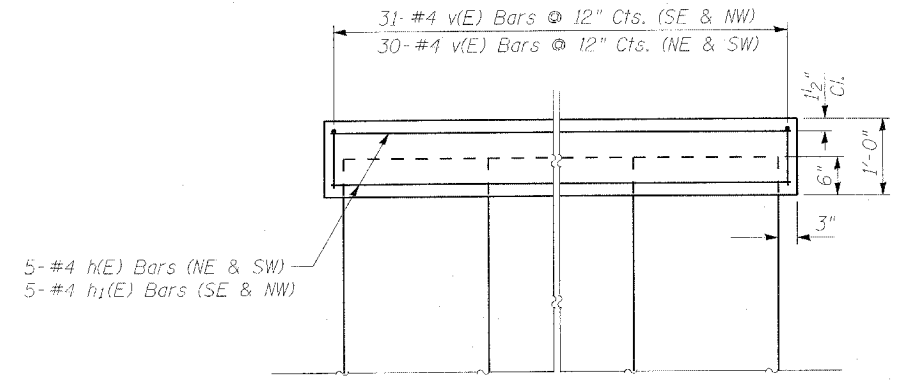

CAP DETAIL

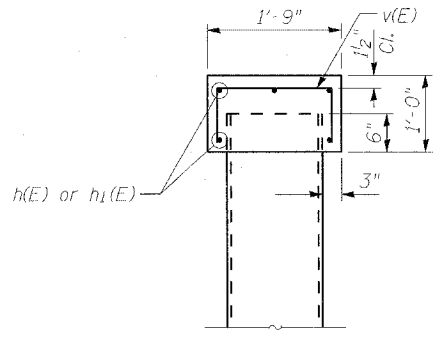

SECTION D-D

Note:
 Maximum Surcharge = 250 psf.
 Protective Coat Shall be Applied to the Concrete Cap.
 Contractor shall begin driving sheets at the ends of the wingwalls away from the Equestrian underpass. Porous granular embankment shall be backfilled behind the proposed wall as the sheeting installation progress to provide additional support to the existing leaning wingwalls. Contractor shall leave existing wingwall bracing in place as long as possible, until prohibited by the driving of sheeting at the bracing locations.

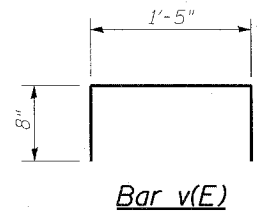

BILL OF MATERIAL

Bar	No.	Size	Length	Shape	
h(E)	10	#4	28'-8"	—	
h1(E)	10	#4	30'-2"	—	
v(E)	122	#4	2'-1"	⌊	
Concrete Structures				Cu. Yd.	7.8
Permanent Steel Sheet Piling				Sq. Ft.	2931
Reinforcement Bars, Epoxy Coated				Pound	620
Stud Shear Connector				Each	48
Protective Coat				Sq. Yd.	52
Porous Granular Embankment				Cu. Yd.	81.2