

PROJECT ENGINEER - REBECCA MARRUFFO

SQUAD LEADER - BRAD CUSHMAN (815)284-5996

F.A.U. RTE.	SECTION	COUNTY	TOTAL SHEETS	SHEET NO.
5857	1R-T	Rock Island	25	1
FED. ROAD DIST. NO.	ILLINOIS	CONTRACT NO. 64E31		

### INDEX

- 1 COVER SHEET
- 2-3 SUMMARY OF QUANTITIES
- 4-5 GENERAL NOTES
- 6 TYPICAL SECTIONS
- 7-8 SCHEDULE OF QUANTITIES
- 9-10 HORIZONTAL & VERTICAL CONTROL
- 11 PLAN & PROFILE
- 12-16 GABION WALL DETAIL
- 17 BORING LOGS
- 18 DETOUR ROUTE DETAIL
- 19 CURB AND GUTTER OUTLET, SPECIAL (18.4)
- DELINEATOR AND POST ORIENTATION (37.4)
- 20 WITNESS MARKER & PERMANENT SURVEY MARKERS, TYPE II (66.2)
- NAME PLATE FOR CULVERTS (88.2)
- 21 ENTRANCE APPROACHES - URBAN AREA (25.1)
- 22 TRAFFIC CONTROL FOR ROAD CLOSURE (40.1)
- 23 DETAILS OF PLANTING AND BRACING TREES (92.1)
- 24-25 CROSS SECTIONS

### STATE STANDARDS

- 280001-05 TEMPORARY EROSION CONTROL SYSTEMS
- 420001-07 PAVEMENT JOINTS
- 442201-03 CLASS C AND D PATCHES
- 606001-04 CONCRETE CURB TYPE B AND COMBINATION CONCRETE CURB AND GUTTER DELINEATORS
- 635001-01 TYPICAL APPLICATION OF TRAFFIC CONTROL STANDARD
- 701006-03 TYPICAL APPLICATION OF TRAFFIC CONTROL STANDARD
- 701301-04 TYPICAL APPLICATION OF TRAFFIC CONTROL STANDARD
- 701501-06 TYPICAL APPLICATION OF TRAFFIC CONTROL STANDARD
- 701311-03 TYPICAL APPLICATION OF TRAFFIC CONTROL STANDARD
- 701901-01 TRAFFIC CONTROL DEVICES
- 720011-01 METAL POST FOR SIGNS, MARKERS AND DELINEATORS
- 728001-01 TELESCOPING STEEL SIGN SUPPORT
- 729001-01 APPLICATIONS OF TYPES A & B METAL POSTS (FOR SIGNS & MARKERS)
- 780001-02 TYPICAL PAVEMENT MARKINGS

# STATE OF ILLINOIS

## DEPARTMENT OF TRANSPORTATION

### DIVISION OF HIGHWAYS

# PROPOSED HIGHWAY PLANS

**FAU ROUTE 5857 (IL 84)**  
**SECTION 1R-T**  
**PROJECT M - 5857(001)**

**ROCK ISLAND COUNTY**

D-92-084-08

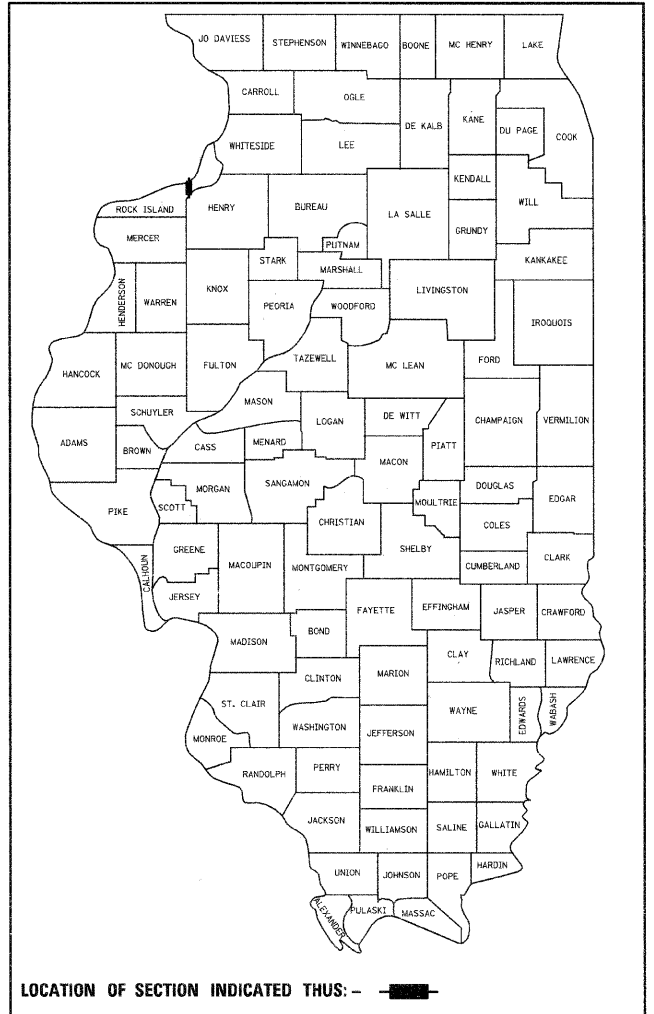

C-92-188-09

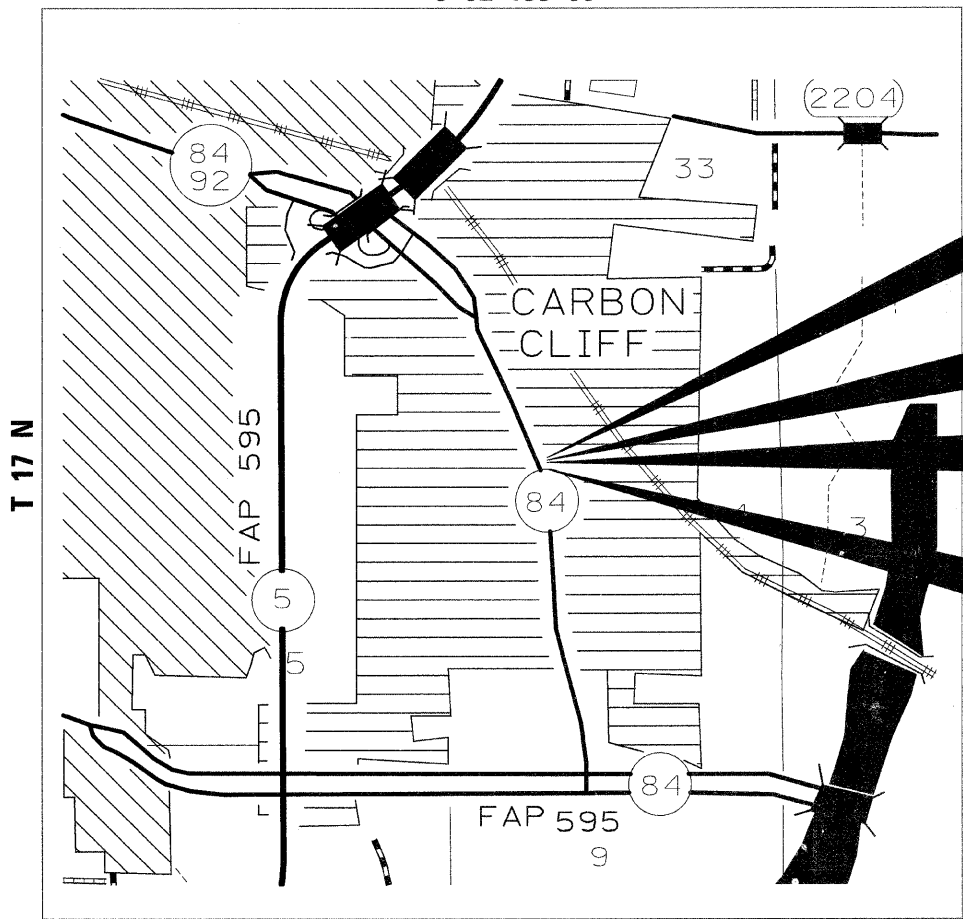

**IMPROVEMENT BEGINS**  
**STA. 67 + 77**

**SECTION BEGINS**  
**STA. 68 + 74**

**SECTION ENDS**  
**STA. 69 + 27**

**IMPROVEMENT ENDS**  
**STA. 70 + 00**

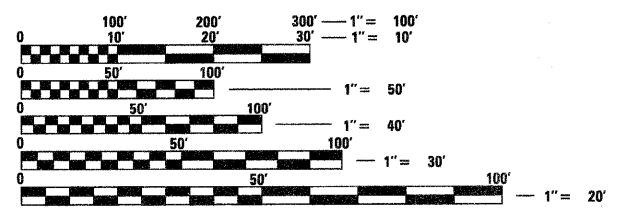

FULL SIZE PLANS HAVE BEEN PREPARED USING STANDARD ENGINEERING SCALES. REDUCED SIZED PLANS WILL NOT CONFORM TO STANDARD SCALES. IN MAKING MEASUREMENTS ON REDUCED PLANS, THE ABOVE SCALES MAY BE USED.

J.U.L.I.E.  
 JOINT UTILITY LOCATION INFORMATION FOR EXCAVATION  
 1-800-892-0123  
 OR 811

HAMPTON TOWNSHIP, SECTION 4

GROSS LENGTH = 53 FT. = 0.01 MILE  
 NET LENGTH = 53 FT. = 0.01 MILE

**CONTRACT NO. 64E31**

ROCK ISLAND COUNTY SECTION 1R-T FAU ROUTE 5857

STATE OF ILLINOIS  
 DEPARTMENT OF TRANSPORTATION  
 DIVISION OF HIGHWAYS

SUBMITTED Oct 8 20 10

George F. Ryan  
 DEPUTY DIRECTOR OF HIGHWAYS, REGION ENGINEER

December 10 20 10  
Scott E. Stitt, P.E. Ia  
 acting ENGINEER OF DESIGN AND ENVIRONMENT

December 10 20 10  
Christine M. Reed Ia  
 DIRECTOR OF HIGHWAYS, CHIEF ENGINEER

**PRINTED BY THE AUTHORITY  
 OF THE STATE OF ILLINOIS**

# SUMMARY OF QUANTITIES

			URBAN
			0040
			80% FED 20% STATE
CODE NUMBER	ITEM	UNIT	TOTAL QUANTITY
20100110	TREE REMOVAL (6 TO 15' DIAMETER (UNITS))	UNIT	48
20100210	TREE REMOVAL (OVER 15' DIAMETER (UNITS))	UNIT	54
20200100	EARTH EXCAVATION	CU YD	110
20200200	ROCK EXCAVATION	CU YD	22
* 25100630	EROSION CONTROL BLANKET	SQ YD	438
* 25200110	SODDING, SALT TOLERANT	SQ YD	278
* 25200200	SUPPLEMENTAL WATERING	UNIT	13
28000305	TEMPORARY DITCH CHECKS	FOOT	20
28000400	PERIMETER EROSION BARRIER	FOOT	171
28000500	INLET <sup>AND</sup> PIPE PROTECTION	EACH	1
28100107	STONE RIPRAP, CLASS A4	SQ YD	147
28200200	FILTER FABRIC	SQ YD	470
28400100	GABIONS	CU YD	288
40603335	HOT-MIX ASPHALT SURFACE COURSE, MIX "D", N50	TON	71
42300300	PORTLAND CEMENT CONCRETE DRIVEWAY PAVEMENT, 7 INCH	SQ YD	56
44000158	HOT-MIX ASPHALT SURFACE REMOVAL, 2 1/4"	SQ YD	214
44000400	GUTTER REMOVAL	FOOT	49
44201383	CLASS C PATCHES, TYPE IV, 12 INCH	SQ YD	155
48101200	AGGREGATE SHOULDERS, TYPE B	TON	32
50100300	REMOVAL OF EXISTING STRUCTURES NO.1	EACH	1
50200100	STRUCTURE EXCAVATION	CU YD	260

\* SPECIALTY ITEMS



# GENERAL NOTES

See cross sections for special ditches and backslopes.

The final top 100 mm (four inches) of soil in any right-of-way area disturbed by the Contractor must be capable of supporting vegetation. The soil must be from the A horizon (zero to 2' deep) of soil profiles of local soils.

All Borrow/Waste/Use sites must be approved by the Department prior to removing any material from the project or initiating any earthmoving activities, including temporary stockpiling outside the limits of construction.

The Contractor shall seed all disturbed areas within the project limits except where sodding is specified. Seeding Class 4 or 2A shall be used, except in front of properties where the grass will be mowed, then use Seeding, Class 1. Class 2A shall be used on front slopes and ditch bottoms. Class 4 shall be used behind Type A gutter, on all backslopes and areas behind the backslope, and beyond the toe of front slope on fill sections without ditches. This work will be included in the contract unit price per Cubic Meter (Cubic Yard) for EARTH EXCAVATION.

Fertilizer shall be applied to all disturbed areas and incorporated into the seedbed prior to seeding or placement of sod at the rate specified in Sections 250 and 252 of the Standard Specifications. This work shall be included in the cost of EARTH EXCAVATION.

Temporary Erosion Control Seeding shall be included in the cost of EARTH EXCAVATION.

Placement and compaction of the backfill for proposed across road culverts and existing across road culverts that are removed shall conform to Section 502.10 of the Standard Specifications, except that the material shall conform to Article 208.02 of the Standard Specifications, and shall be compacted to a minimum of 95% of the standard laboratory density. Any material conforming to the requirements of Article 1003.04 or 1004.05 which has been excavated from the trenches shall be used for backfilling the trenches. The entire excavation, within 2 feet outside of each shoulder, shall be backfilled with trench backfill material to the bottom of the proposed subgrade. Impervious material shall be used on the outer 3 feet of each end of the culvert. This trench backfill material will not be measured for payment, but shall be included in the contract unit price for the class of concrete involved or other unit price item of the work for which it is required.

The following Mixture Requirements are applicable for this project:

Mixture Uses(s):	Surface
PG:	PG 64-22
Design Air Voids	4.0 @ N50
Mixture Composition (Gradation Mixture)	IL 9.5 or 12.5
Friction Aggregate	D
20 Year ESAL	0.5
Mix Unit Weight	112 lb/sy/in

A Nationwide 404 Permit has been issued for this project and the conditions of that permit must be adhered to.

The new number for this structure will be SN 081-1129.

The boring logs for this structure indicate that groundwater levels may encroach on the construction limits of this culvert. It shall be the responsibility of the contractor to control the ground water and divert the stream flow during construction in order to keep the construction area free of water. The method of controlling the water shall be subject to approval of the Engineer and the cost shall be included in the contract unit price for Precast Concrete Box Culverts.

Culvert & bridge flows must be maintained throughout the project. Normal flow shall be allowed to pass at the rate it enters the jobsite. High flows shall be allowed to pass without causing damage to upstream properties.

Delineators shall be installed as shown in Standard 635001, except that the post shall be rotated 180° and only metal-backed delineators shall be permitted. Delineators shall be placed at the ends of approach guardrail terminal sections, and at each headwall or end section of AR Culverts. This work will be paid for at the contract unit price each for DELINEATORS.

PERMANENT SURVEY MARKERS, TYPE II, shall be set at intervals of 1.6 Km (1 mile) or as directed by the Engineer. Bridge or culvert projects shall have one survey marker placed near the structure. Estimated: 2 Each.

Permanent Survey Markers, Type II shall be cast-in-place as shown on District Standard 66.2. The bottom of the marker shall be 5'-0" below the ground surface.

The Contractor shall submit to the Engineer a description of location, elevation, and coordinates for each permanent survey marker. The horizontal and vertical coordinates must be derived by GPS and the elevation derived by a closed level circuit. The Engineer shall submit this information to the Survey Crew.

Tree planting layout shall be performed by the District Landscape Architect. Mulch shall be placed 4" thick and to the diameter around the tree as shown on District Standard 92.1. The mulch shall be hardwood wood chips placed on weed barrier fabric. This work shall be included in the cost of the tree.

The Contractor shall be responsible for protecting utility property during construction operations as outlined in Article 107.31 of the Standard Specifications. A minimum of 48 hours advance notice is required for non-emergency work. The JULIE number is 800-892-0123. The following listed utilities located within the project limits or immediately adjacent to the project construction limits are members of JULIE:

AT&T (Telephone) Attn: Mr. Dave Creen 309/793-4456	MidAmerican Energy Co. (Electric) Attn: Mr. Jeff Berry 309/793-3833
MidAmerican Energy Co. (Gas) Attn: Steve Hampton 309/793-3707	Paetec (Telephone) Attn: Mr. Paul Baumann 630/925-4751
Mediacom (CATV) Attn: Mr. Dennis Jarding 309/743-4750	MCI World Com (Telephone) Attn: Mr. Bailey Ken 972/729-6016
Village of Carbon Cliff (Water & Sewer) Attn: Ms. Dawn Tubbs 309/792-8297	

The applicable portions of Article 105.07 of the Standard Specification shall apply except for the following: The Contractor shall be responsible to locate the vertical depths of the underground utilities which may interfere with construction operations. This work will not be measured or paid for separately, but shall be considered as included in the unit bid price for the item of construction involved.

Bituminous and Aggregate prime coat shall be placed in accordance with Section 406 of the Standard Specifications. The cost of the prime coats shall be included in the contract unit price per metric ton (ton) for HOT-MIX ASPHALT SURFACE COURSE, MIX "D", N50.

Per SB 699 (90 day utility relocation law), once right-of-way is clear to award the project, a notice will be sent to the utility companies instructing them to have their facilities relocated within 90 days. Estimated date relocation complete = Letting Date + 135 days.

FILE NAME = 64E31 GN.DOCX	USER NAME =	DESIGNED - Engineering Systems	REVISED -	<b>STATE OF ILLINOIS DEPARTMENT OF TRANSPORTATION</b>	<b>GENERAL NOTES</b>	ROUTE	SECTION	COUNTY	TOTAL SHEETS	SHEET NO.
		DRAWN -	REVISED -			FAU 5857	1R-T	Rock Island	25	4
	PLOT SCALE =	CHECKED -	REVISED -			(IL 84)		CONTRACT NO. 64E31		
	PLOT DATE = 10/8/2010 7:43 AM	DATE - 11/5/2009 12:06 PM	REVISED -			SCALE:	SHEET NO.	OF	SHEETS	STA.

# GENERAL NOTES

CADD data will be available to Contractors and Consultants working on this project. This information will be provided upon request as MicroStation CADD files and Geopak coordinate geometry files ONLY. If data is required in other formats it will be your responsibility to make these conversions. If any discrepancy or inconsistency arises between the electronic data and the information on the hard copy, the information on the hard copy should be used. Contact the District's Project Engineer to request these files.

It shall be the Contractor's responsibility to contact the municipality to determine approved methods of utility structure adjustment. Utility structures may include, but are not limited to, manholes, water valves, handholes, etc. All materials and work necessary to complete adjustments per municipality requirements shall be considered included in the cost of the associated adjustment pay item.

FILE NAME = 64E31 GN.DOCX	USER NAME =	DESIGNED - Engineering Systems	REVISED -	<b>STATE OF ILLINOIS DEPARTMENT OF TRANSPORTATION</b>	<b>GENERAL NOTES</b>	ROUTE	SECTION	COUNTY	TOTAL SHEETS	SHEET NO.		
		DRAWN -	REVISED -			FAU 5857	1R-T	Rock Island	25	5		
	PLOT SCALE =	CHECKED -	REVISED -			(IL 84)	CONTRACT NO. 64E31					
	PLOT DATE = 10/6/2010 7:43 AM	DATE = 11/5/2009 12:06 PM	REVISED -			SCALE: SHEET NO. OF SHEETS STA. TO STA.		ILLINOIS	FED. AID PROJECT			

# TYPICAL SECTIONS

STA. 68+74 - 69+27

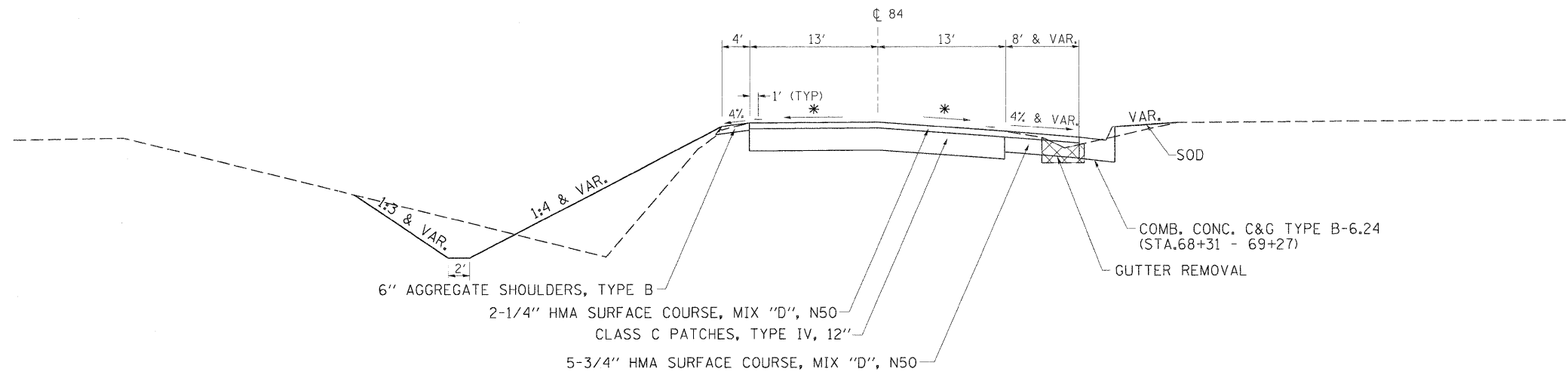

STA. 68+31 - 68+74

\* MATCH EXISTING CROSS SLOPE

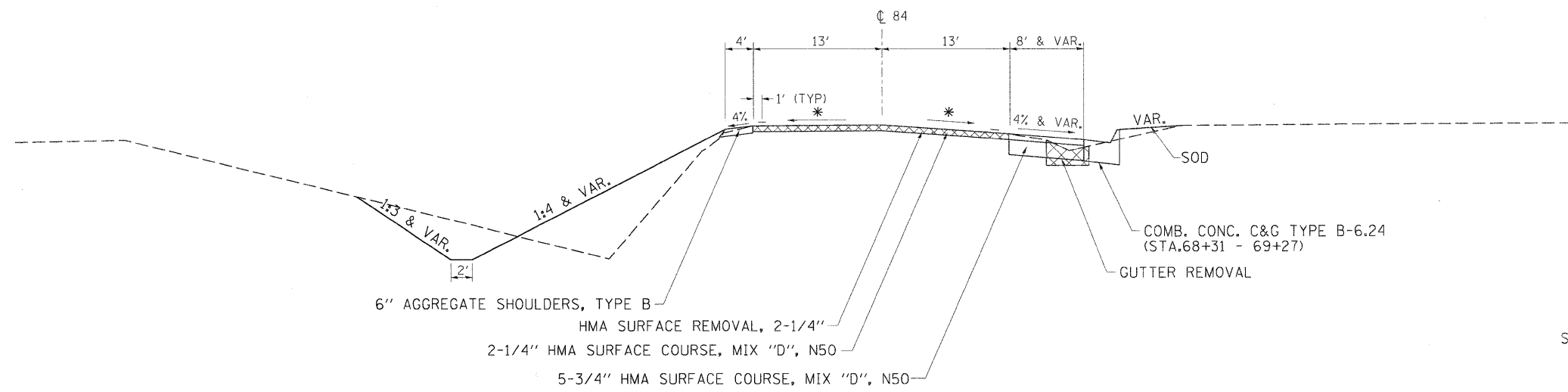

STA. 69+27 - 70+00

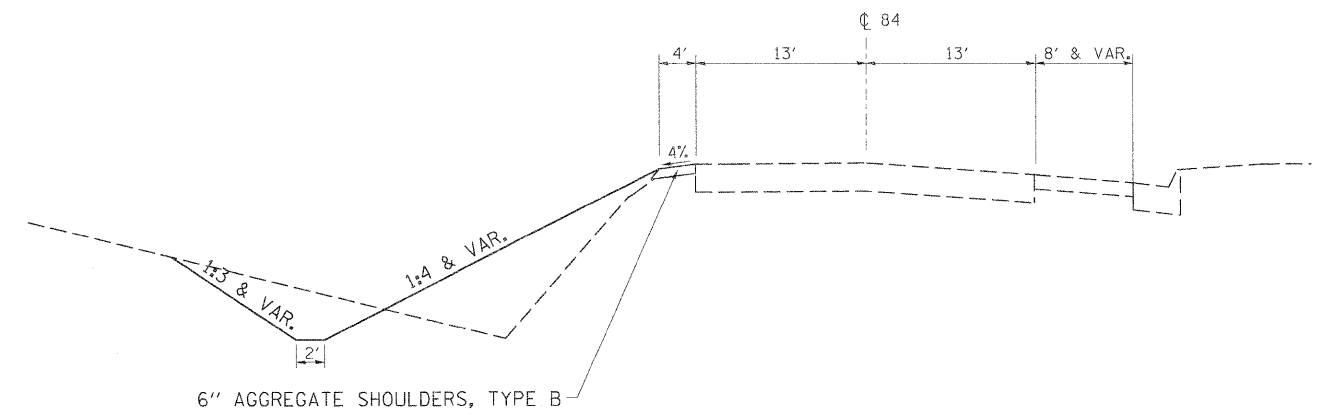

FILE NAME =	USER NAME = cushmanbw	DESIGNED -	REVISED -
c:\pwork\pwork\cushmanbw\ad0133431\0264408-shr-typ10e1.dgn		DRAWN -	REVISED -
PLOT SCALE = 20.0000' / IN.		CHECKED -	REVISED -
PLOT DATE = Wed Oct 06 07:52:29 2010		DATE -	REVISED -

STATE OF ILLINOIS  
DEPARTMENT OF TRANSPORTATION

## TYPICAL SECTIONS

SCALE: SHEET NO. OF SHEETS STA. TO STA.

F.A.U. RTE.	SECTION	COUNTY	TOTAL SHEETS	SHEET NO.
5857	1R-T	ROCK ISLAND	25	6
CONTRACT NO. 64E31			ILLINOIS FED. AID PROJECT	



# SCHEDULE OF QUANTITIES

63500105	DELINEATORS EACH <u>2</u> 2	LT/RT TOTAL	LOCATION 69 + 0	REMARK'S		
66700305	PERMANENT SURVEY MARKERS, TYPE II EACH <u>2</u> 2		LOCATION TO BE DETERMINED BY FIELD ENGINEER TOTAL	REMARK'S		
78001110	PAINTE PAVEMENT MARKING - LINE 4" EQUI 676 <u>100</u> 776	LT & RT STA CL STA.	68 + 31 68 + 31	TO TO	70 + 0 70 + 0	REMARK'S WHITE EOP (2) APPLICATIONS YELLOW SKIP DASH (2) APPLICATIONS
X2070302	POROUS GRANULAR EMBANKMENT, SPECIAL TON <u>60.0</u> 60.0	LT & RT. STA.	69 + 0			REMARK'S Used as sub-base for PreCast Box Culvert
Z0025500	FURNISHING AND INSTALLING PROPERTY MARKERS EACH 1 1 1 1 1 1 1 1 1 1 <u>10</u>	STA.	68 + 65 68 + 74.64 68 + 75 68 + 65 68 + 95.37 69 + 0.00 69 + 26.58 69 + 38 70 + 15 70 + 15 TOTAL	30' RT 86.44' RT 50' RT 85' RT 89.37' RT 90' RT 80' LT 25' RT 55' LT 30' LT	REMARK'S	





# HORIZONTAL & VERTICAL CONTROL

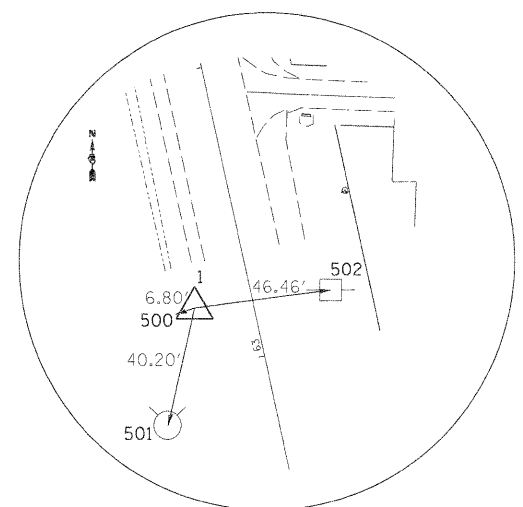
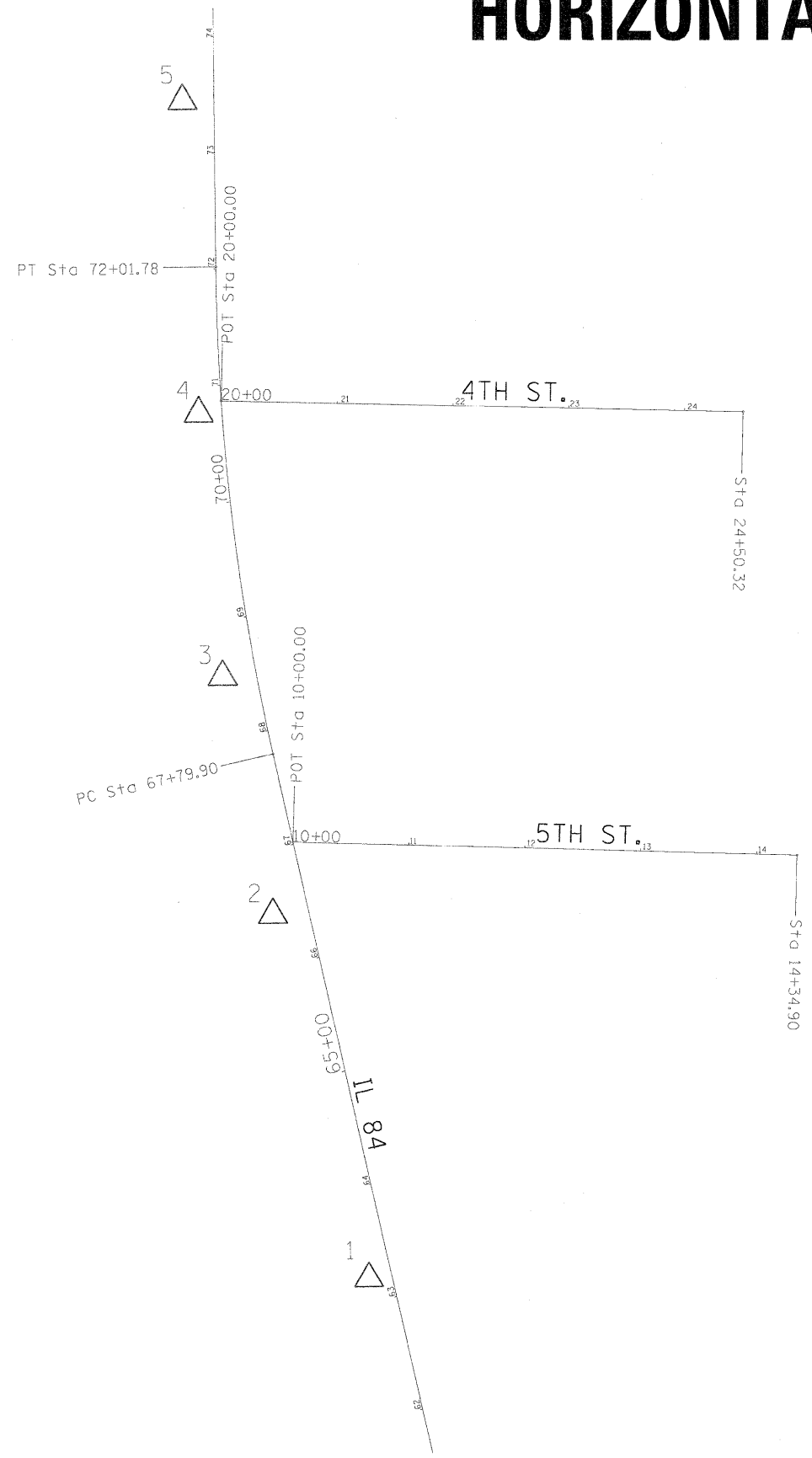

HORIZONTAL CONTROL POINT 1

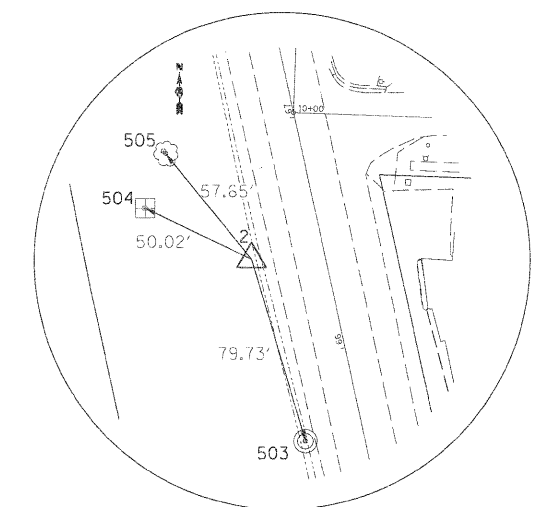

HORIZONTAL CONTROL POINT 2

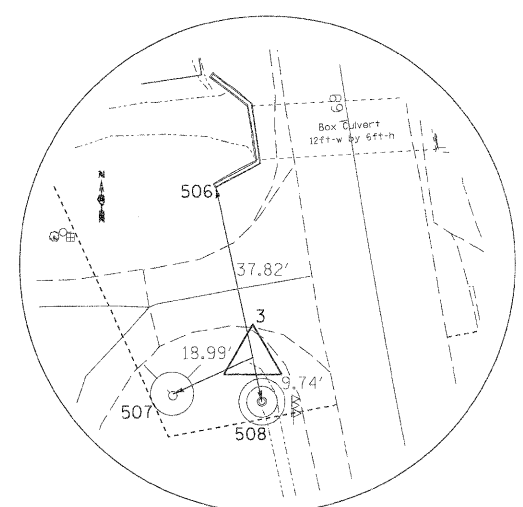

HORIZONTAL CONTROL POINT 3

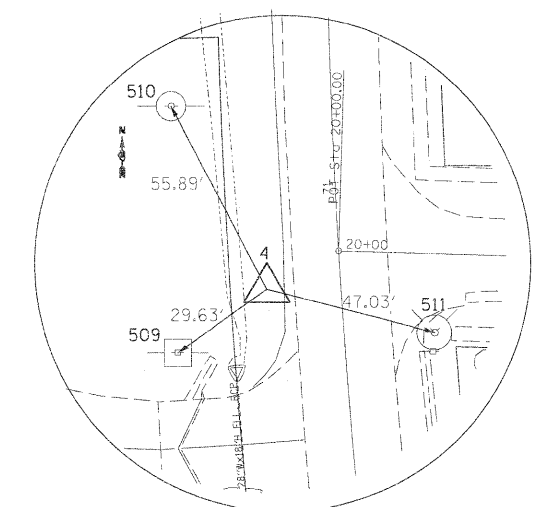

HORIZONTAL CONTROL POINT 4

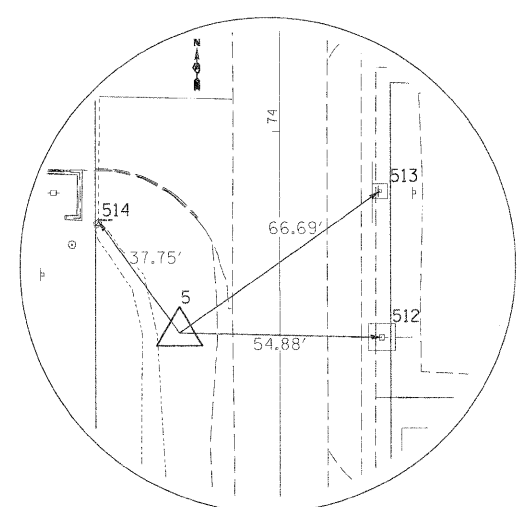

HORIZONTAL CONTROL POINT 5

Curve Data

Curve 250  
 P.I. Station 69+91.6558 N 1,757,760.0823 E 2,235,299.7178  
 Delta = 12° 17' 50.7463" (RT)  
 Degree = 2° 54' 53.7421"  
 Tangent = 211.7523'  
 Length = 421.8776'  
 Radius = 1,965.5982'  
 External = 11.3730'  
 Long Chord = 421.0683'  
 Mid. Ord. = 11.3076'  
 P.C. Station 67+79.9034 N 1,757,553.2168 E 2,235,344.9474  
 P.T. Station 72+01.7810 N 1,757,971.8345 E 2,235,299.5855  
 C.C. N 1,757,973.0625 E 2,237,265.1833

Course from PT 250 to PC 260 359° 57' 51.1422" Dist 866.1301'

DRAWING NTS

FILE NAME =	USER NAME = cushmanbw	DESIGNED -	REVISED -	<b>STATE OF ILLINOIS DEPARTMENT OF TRANSPORTATION</b>	<b>HORIZONTAL &amp; VERTICAL CONTROL</b>	F.A.U. RTE.	SECTION	COUNTY	TOTAL SHEETS	SHEET NO.
ca:\pwork\pwork\dot\cushmanbw\d0133431\0204\04-08-sh-t-ATB.dgn	DRAWN -	REVISED -	5857			IR-T	ROCK ISLAND	25	10	
PLOT SCALE = 50.0000' / IN.	CHECKED -	REVISED -	CONTRACT NO. 64E31							
PLOT DATE = Wed Oct 06 08:07:47 2010	DATE -	REVISED -	ILLINOIS FED. AID PROJECT							
				SCALE:	SHEET NO. OF SHEETS	STA. TO STA.				

# STA. 69+00 DOUBLE 8' x 5' BOX CULVERT



Drainage Area = 609 Acres				
Existing Low Grade Elevation: 592.00 ft. @ 68+70				
Proposed Low Grade Elevation: 592.00 ft. @ 68+70				
FLOOD	FREQUENCY	DISCHARGE	HEADWATER ELEV. (ft)	
	Year	cfs	Existing	Proposed
Ten-Year	10	356	589.50	587.14
Design	50	595	591.57	589.37
Base	100	706	592.25	590.60
OVT (E)	63	642	592.00	
OVT (P)	185	816		592.00

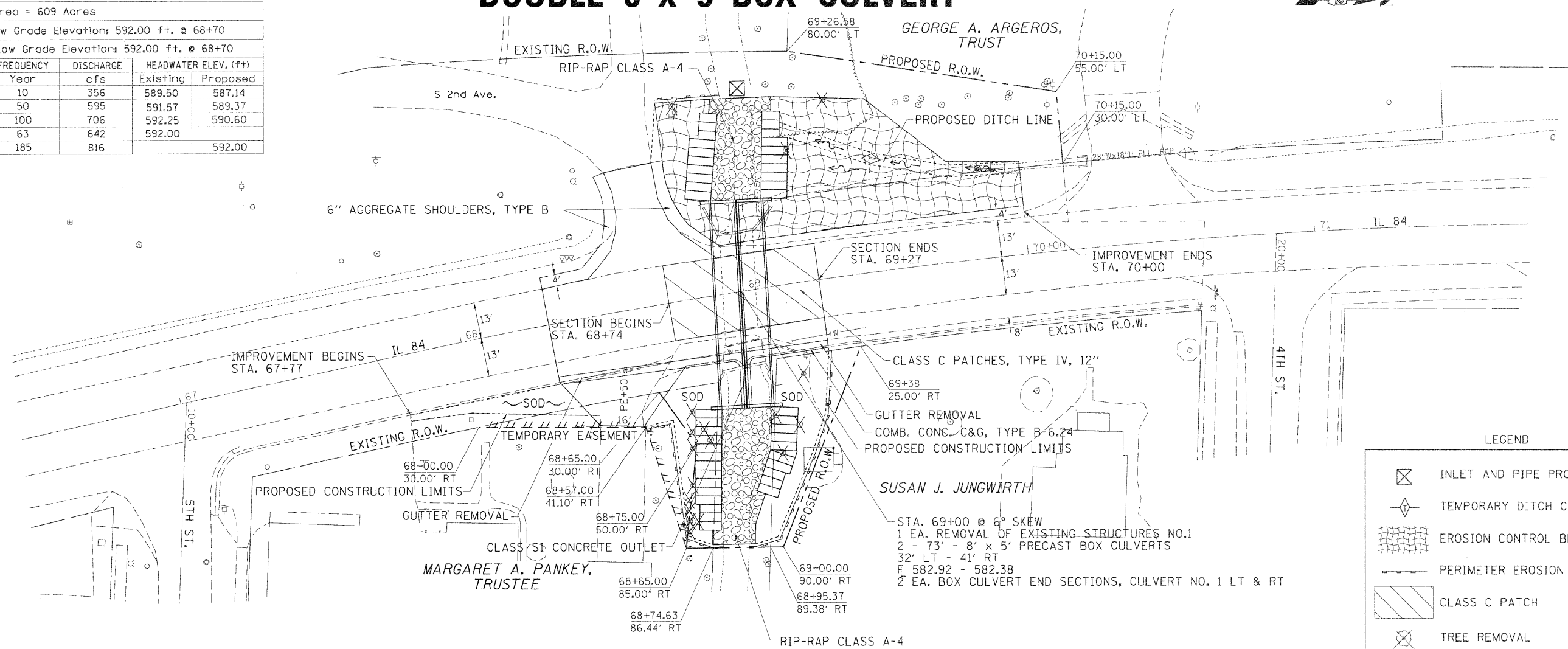

- LEGEND**
- INLET AND PIPE PROTECTION
  - TEMPORARY DITCH CHECK
  - EROSION CONTROL BLANKET
  - PERIMETER EROSION BARRIER
  - CLASS C PATCH
  - TREE REMOVAL

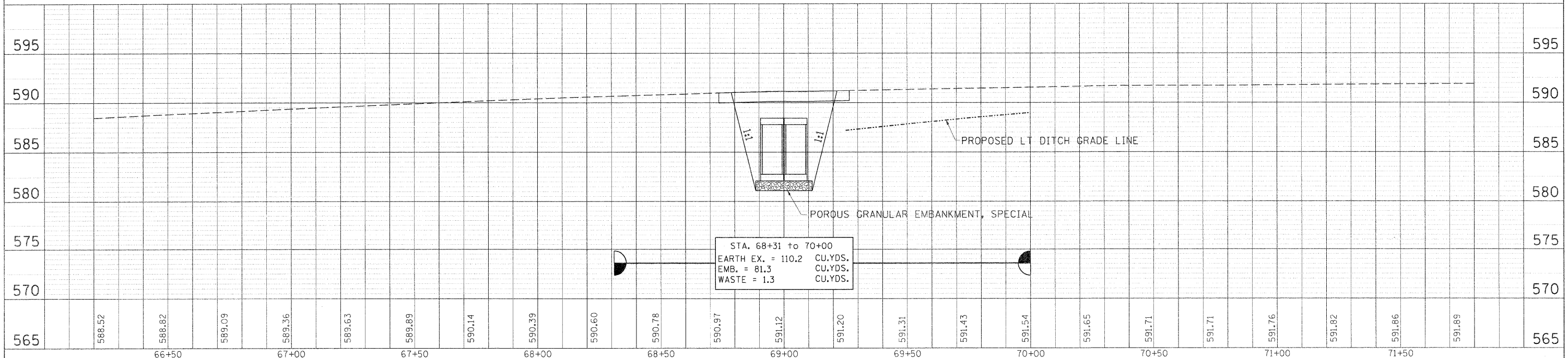

FILE NAME =	USER NAME = cushmanbw	DESIGNED -	REVISED -	<b>STATE OF ILLINOIS</b>		<b>STA. 69+00</b>		F.A.U. RTE.	SECTION	COUNTY	TOTAL SHEETS	SHEET NO.
c:\pwork\pwork\cushmanbw\d8133431\0208	08-shit-plnpr-f.dgn	DRAWN	REVISED	<b>DEPARTMENT OF TRANSPORTATION</b>		<b>DOUBLE 8' x 5' BOX CULVERT</b>		5857	1R-T	ROCK ISLAND	25	11
PLOT SCALE = 20.0000' / IN.	CHECKED	REVISED	REVISED					CONTRACT NO. 64E31				
PLOT DATE = Wed Oct 26 08:08:46 2010	DATE	REVISED	REVISED					ILLINOIS FED. AID PROJECT				

NOTE BOOK NO. \_\_\_\_\_  
 ALIGNED CHECKED BY: \_\_\_\_\_  
 RT. OF WAY CHECKED BY: \_\_\_\_\_  
 GRID FILE NAME: \_\_\_\_\_  
 NOTE BOOK NO. \_\_\_\_\_  
 GRASS CHECKED BY: \_\_\_\_\_  
 S.M. NOTED BY: \_\_\_\_\_  
 STRUCTURE NOTES CHD: \_\_\_\_\_

**GENERAL NOTES**

This work shall be done according to the applicable portion of 284, 503 and 508 of the Standard Specifications.  
 Reinforcement bars shall conform to the requirements of ASTM A 706 Gr 60.  
 Layout of slope protection system may be varied to suit ground conditions in the field as directed by the Engineer.  
 Filter fabric shall be placed underneath and on the back face of the gabion walls.  
 Exposed edges shall be beveled 3/4"

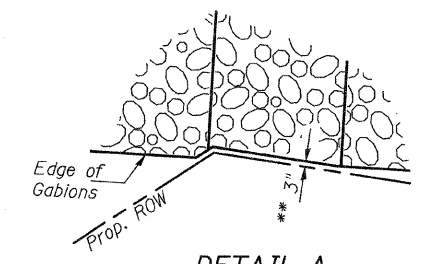
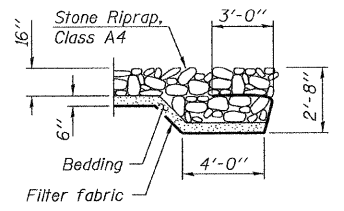
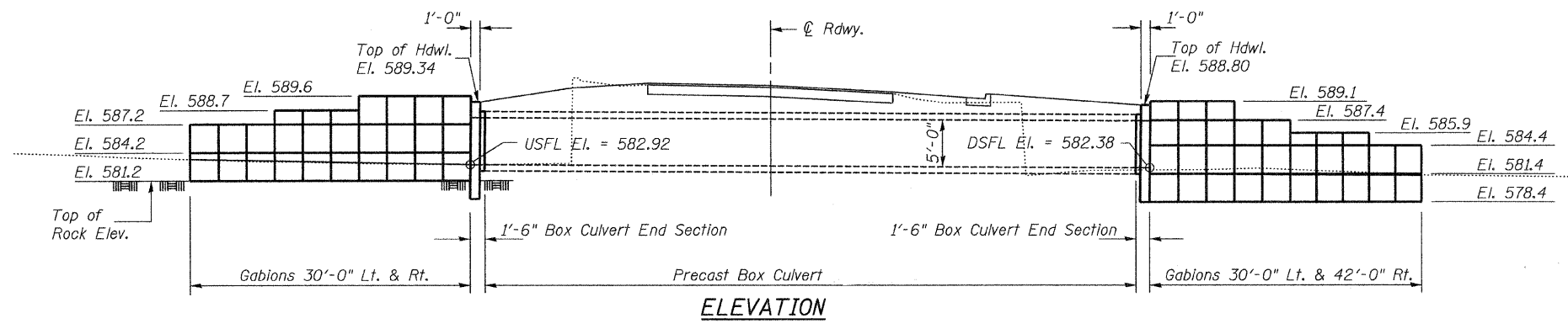

**TOTAL BILL OF MATERIAL**

ITEM	UNIT	TOTAL
Structure Excavation	Cu. Yd.	260.0
Rock Excavation	Cu. Yd.	2.0
Stone Riprap, Class A4	Sq. yd.	147.0
Filter Fabric	Sq. yd.	470.0
<del>Removal of Existing Structures</del>	<del>Each</del>	<del>1</del>
Box Culvert End Sections, Culvert No. 1	Each	2
Gabions	Cu. Yd.	288.0

**DESIGN STRESSES**

**FIELD UNITS**  
 f'c = 3,500 psi  
 fy = 60,000 psi (Reinforcement)

**DESIGN SPECIFICATIONS**

2007 AASHTO LRFD Bridge Design Specifications with 2008 and 2009 Interims

**LOADING HL-93**

Allow 50#/Sq. Ft. For future wearing surface.

**INDEX OF SHEETS**

- 1 - General Plan & Elevation
- 2-3 - Box Culvert End Section Details
- 4 - Gabion Wall Details
- 5 - Bar Splicer Assembly Details

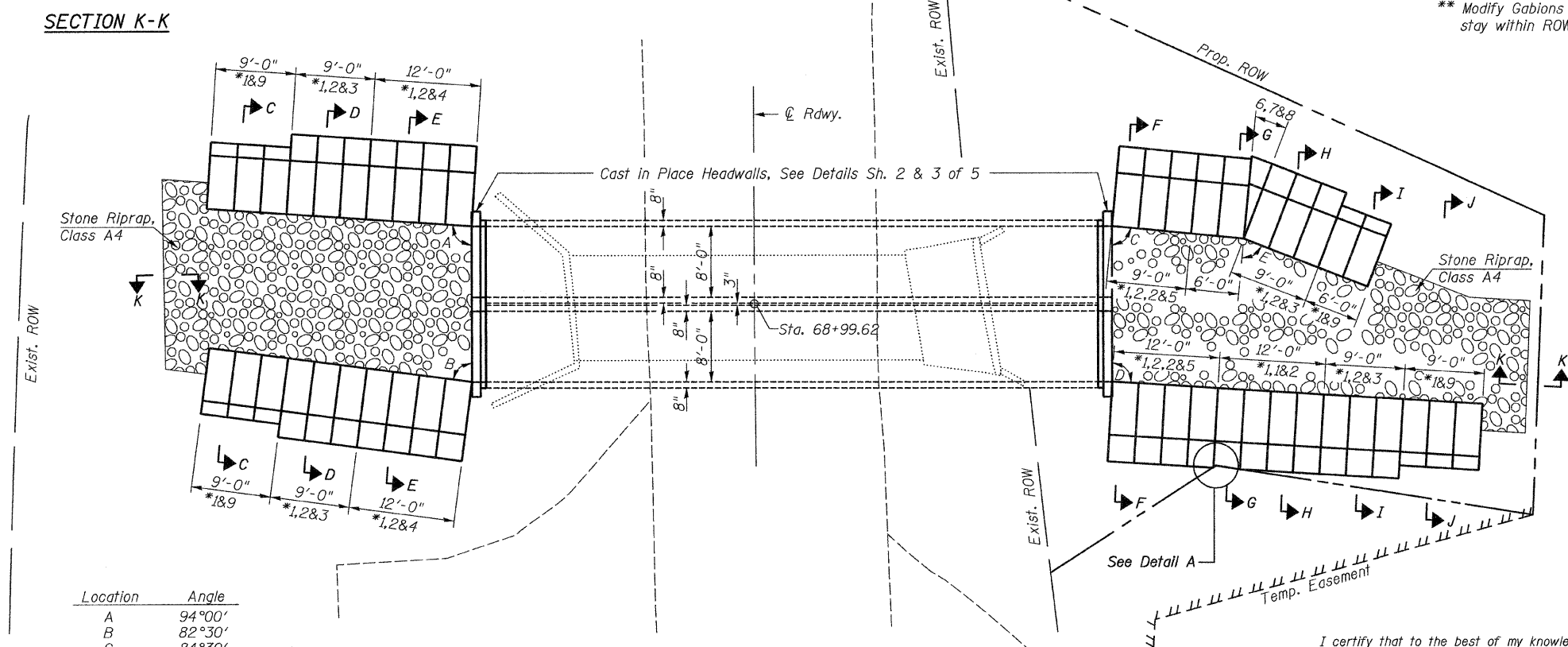

Location	Angle
A	94°00'
B	82°30'
C	84°30'
D	93°30'
E	74°30'

\* Gabions, See Sheet 4 of 5 For Details

I certify that to the best of my knowledge, information and belief, this bridge design is structurally adequate for the design loading shown on the plans. The design is an economical one for the style of structure and complies with requirements of the current AASHTO LRFD Bridge Design Specifications.

*Benjamin A. Nebel* 7/27/2010  
 Illinois Structural No. 6527  
 Expires 11/30/2010

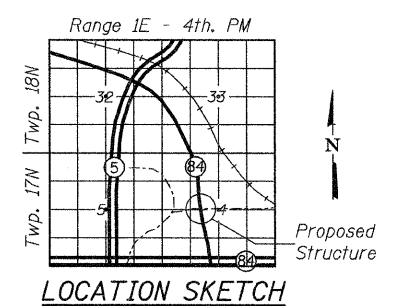

**GENERAL PLAN & ELEVATION**  
**IL. RTE. 84 OVER UNNAMED CREEK**  
**F.A.S. RTE. 5857 - SEC. 1R-T**  
**ROCK ISLAND COUNTY**  
**STATION 68+99.62**

DESIGNED - BAN	EXAMINED _____	DATE - ____	<b>STATE OF ILLINOIS DEPARTMENT OF TRANSPORTATION</b>	<b>BOX CULVERT END SECTION &amp; GABION WALL DETAILS</b>	F.A.S. RTE. 5857	SECTION 1R-T	COUNTY ROCK ISLAND	TOTAL SHEETS 25	SHEET NO. 12
CHECKED - _____	ENGINEER OF BRIDGE DESIGN				ILLINOIS FED. AID PROJECT				
DRAWN - TAC	PASSED _____				CONTRACT NO. 64E31				
CHECKED - _____	ENGINEER OF BRIDGES AND STRUCTURES				SHEET NO. 1 OF 5 SHEETS				

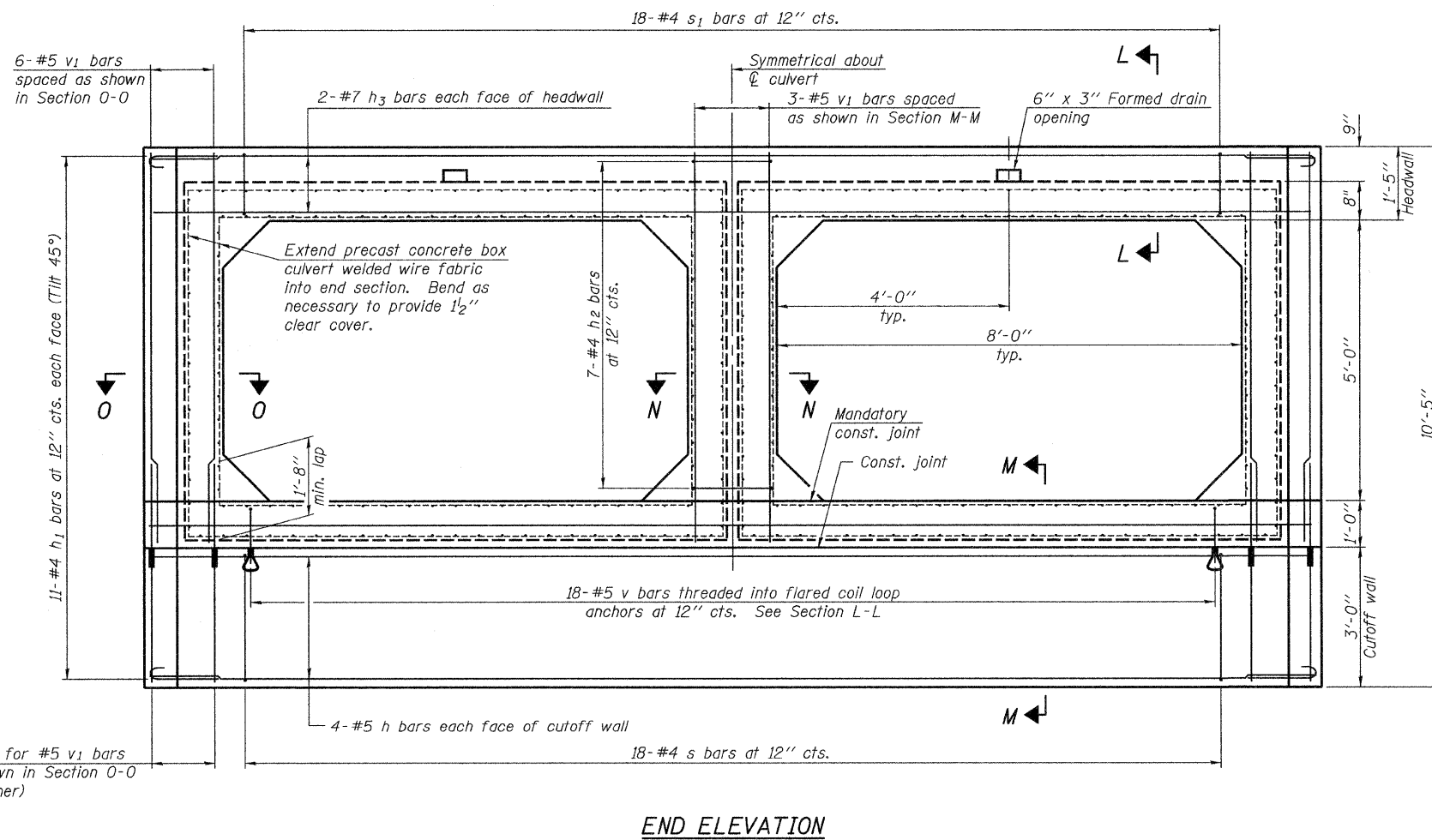
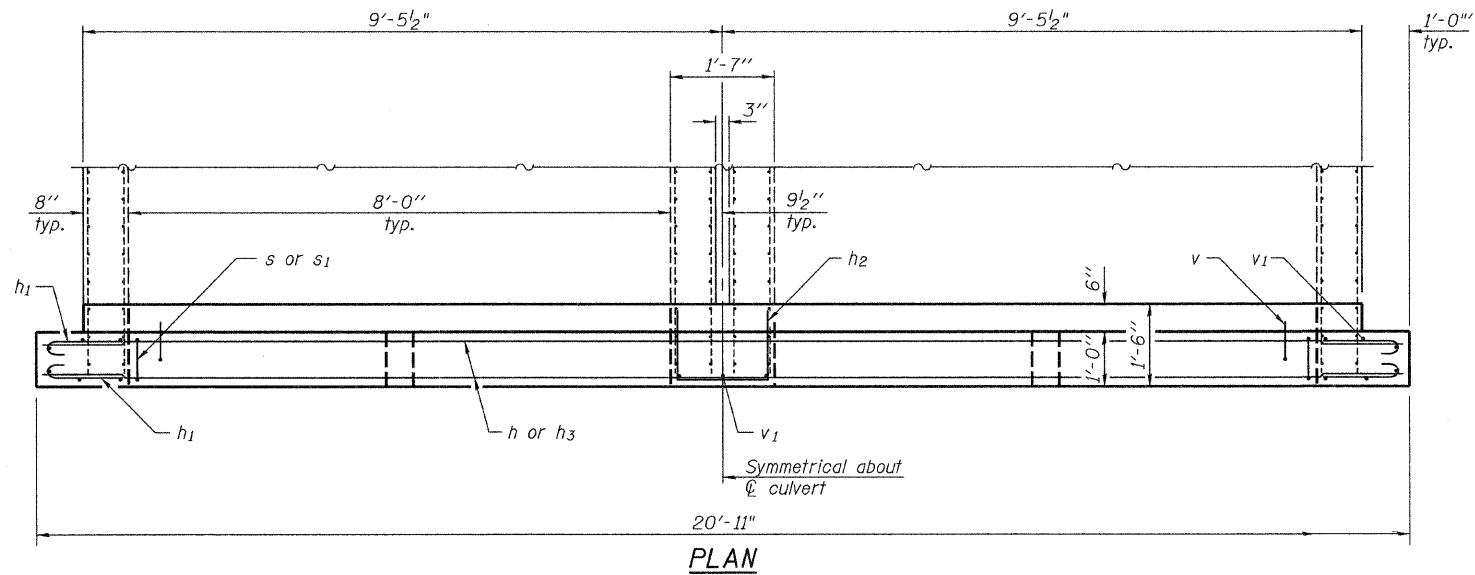

6 Bar Splicers for #5 v<sub>1</sub> bars spaced as shown in Section O-O (Typ. each corner)

**BOX CULVERT END SECTION DETAILS**  
**IL. RTE. 84 OVER UNNAMED CREEK**  
**F.A.S. RTE. 5857 - SEC. 1R-T**  
**ROCK ISLAND COUNTY**  
**STATION 68+99.62**

DESIGNED - BAN	EXAMINED _____	DATE - ____	<b>STATE OF ILLINOIS</b> <b>DEPARTMENT OF TRANSPORTATION</b>	<b>BOX CULVERT END SECTION &amp;</b> <b>GABION WALL DETAILS</b>	F.A.S. RTE. 5857	SECTION 1R-T	COUNTY ROCK ISLAND	TOTAL SHEETS 25	SHEET NO. 13	
CHECKED - _____	ENGINEER OF BRIDGE DESIGN				CONTRACT NO. 64E31					
DRAWN - TAC	PASSED _____				ILLINOIS FED. AID PROJECT					
CHECKED - _____	ENGINEER OF BRIDGES AND STRUCTURES				SHEET NO. 2 OF 5 SHEETS					

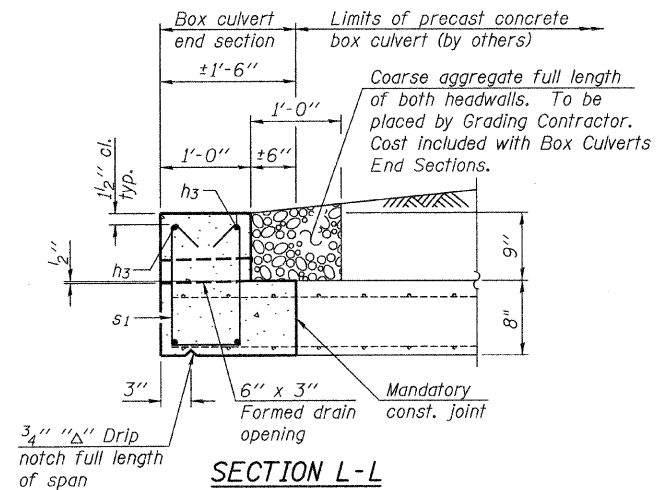

SECTION L-L

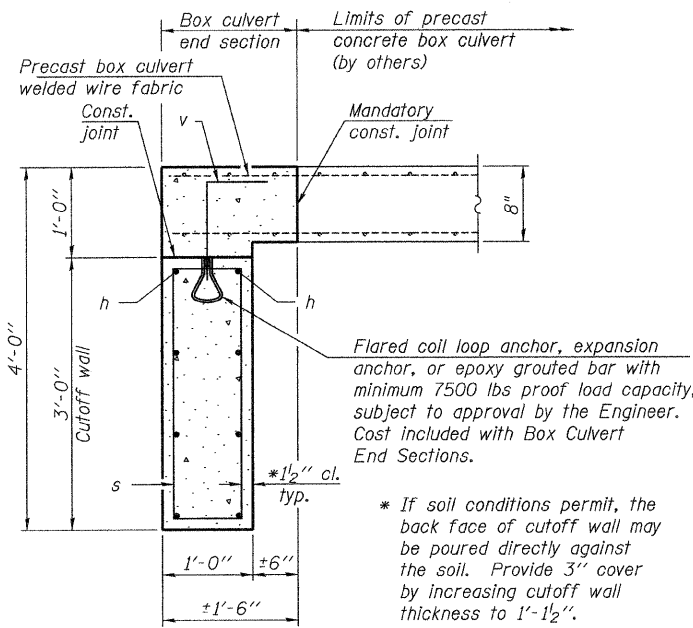

SECTION M-M

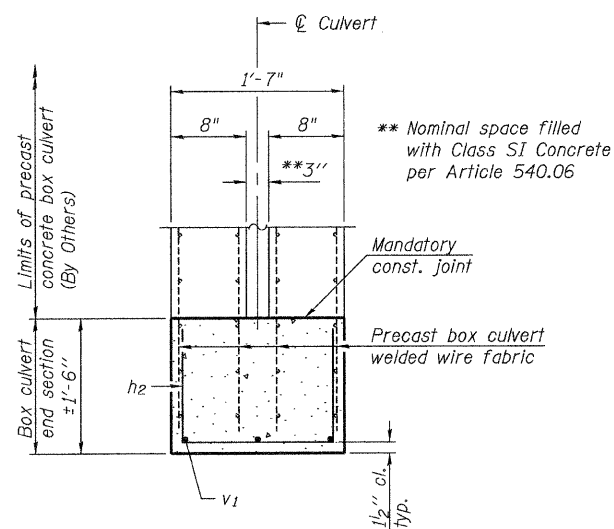

SECTION N-N

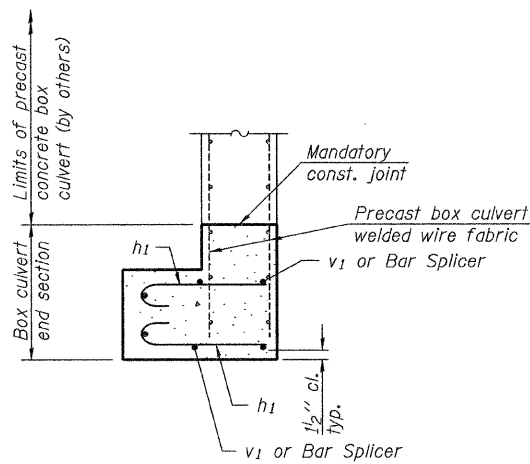

SECTION O-O (Showing reinforcement)

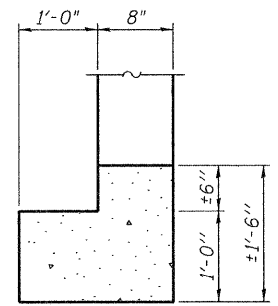

SECTION O-O (Showing dimensions)

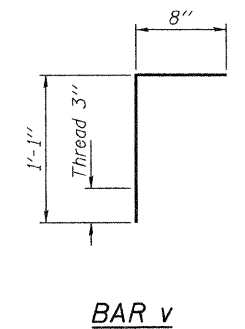
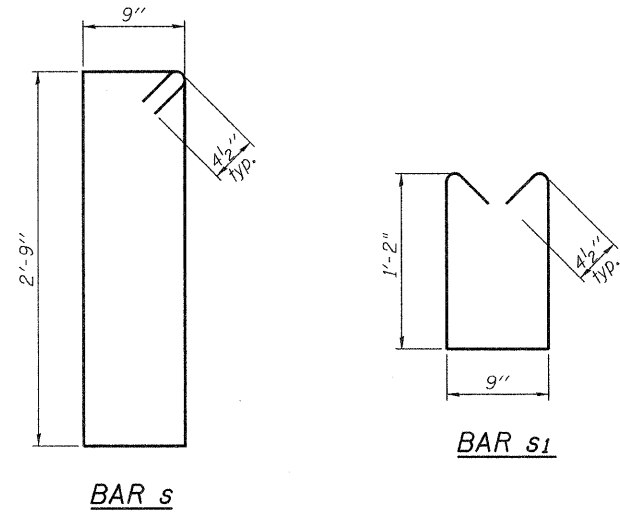
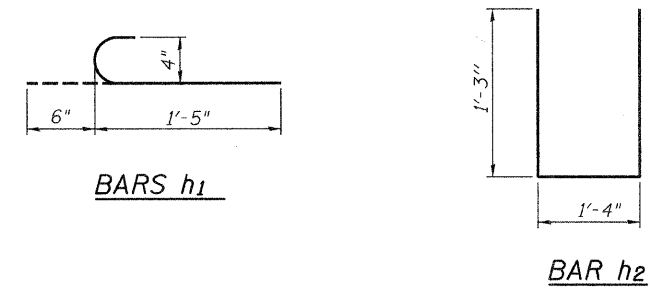

ONE END SECTION BILL OF MATERIAL (For information only)

Bar	No.	Size	Length	Shape	
h	8	#5	19'-8"	—	
h <sub>1</sub>	44	#4	1'-11"	C	
h <sub>2</sub>	7	#4	3'-10"	U	
h <sub>3</sub>	4	#7	19'-8"	—	
s	18	#4	7'-9"	□	
s <sub>1</sub>	18	#4	3'-10"	□	
v	18	#5	1'-9"	—	
v <sub>1</sub>	15	#5	7'-2"	—	
Concrete Box Culverts				Cu. Yd.	5.9
Reinforcement Bars				Pound	680
Bar Splicers				Each	12

BOX CULVERT END SECTION DETAILS  
 IL. RTE. 84 OVER UNNAMED CREEK  
 F.A.S. RTE. 5857 - SEC. 1R-T  
 ROCK ISLAND COUNTY  
 STATION 68+99.62

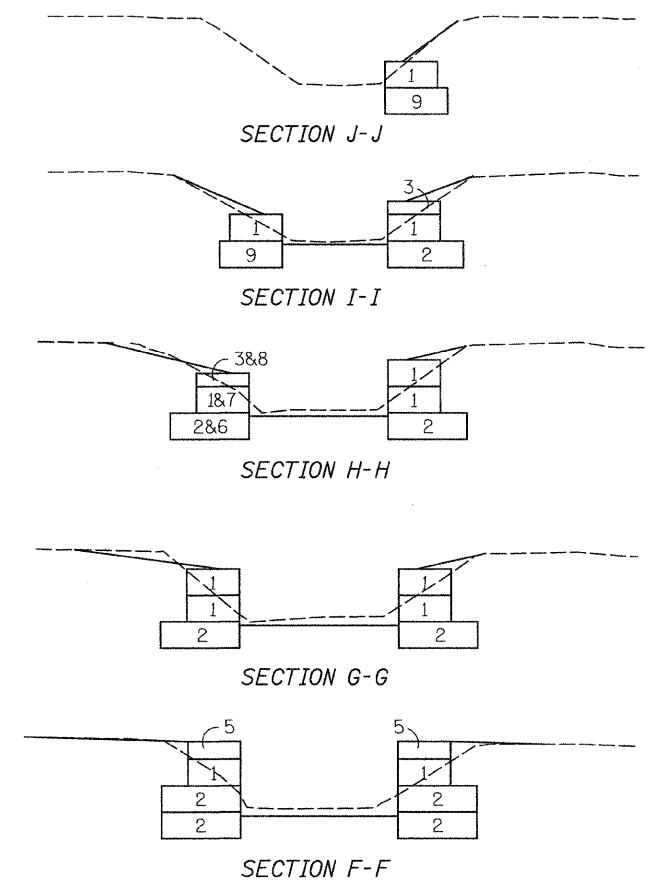
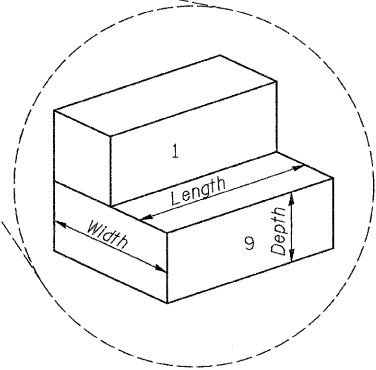
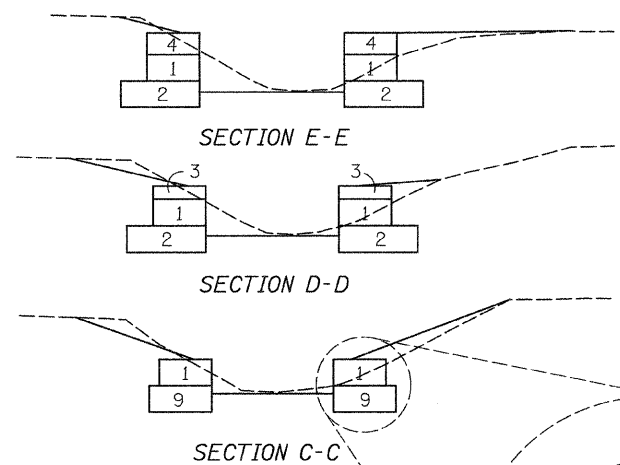

**GABIONS**

Gabion	Length	Width	Depth
1	3'-0"	6'-0"	3'-0"
2	3'-0"	9'-0"	3'-0"
3	3'-0"	6'-0"	1'-6"
4	3'-0"	6'-0"	2'-5"
5	3'-0"	6'-0"	1'-9"
6	varies	9'-0"	3'-0"
7	varies	6'-0"	3'-0"
8	varies	6'-0"	1'-6"
9	3'-0"	7'-6"	3'-0"

**GABION WALL DETAILS**  
**IL. RTE. 84 OVER UNNAMED CREEK**  
**F.A.S. RTE. 5857 - SEC. 1R-T**  
**ROCK ISLAND COUNTY**  
**STATION 68+99.62**

DESIGNED - BAN	EXAMINED _____ DATE - ___-___-___
CHECKED - ___	ENGINEER OF BRIDGE DESIGN
DRAWN - TAC	PASSED _____
CHECKED - ___	ENGINEER OF BRIDGES AND STRUCTURES

**STATE OF ILLINOIS**  
**DEPARTMENT OF TRANSPORTATION**

**BOX CULVERT END SECTION &**  
**GABION WALL DETAILS**  
 SHEET NO. 4 OF 5 SHEETS

F.A.S. RTE. 5857	SECTION 1R-T	COUNTY ROCK ISLAND	TOTAL SHEETS 25	SHEET NO. 15
CONTRACT NO. 64E31			ILLINOIS FED. AID PROJECT	

The diameter of this part is the same as the diameter of the bar spliced.

The diameter of this part is equal or larger than the diameter of bar spliced.

**ROLLED THREAD DOWEL BAR**



**\*\* ONE PIECE**

Wire Connector



**WELDED SECTIONS**

**BAR SPLICER ASSEMBLY ALTERNATIVES**

\*\*Heavy Hex Nuts conforming to ASTM A 563, Grade C, D or DH may be used.

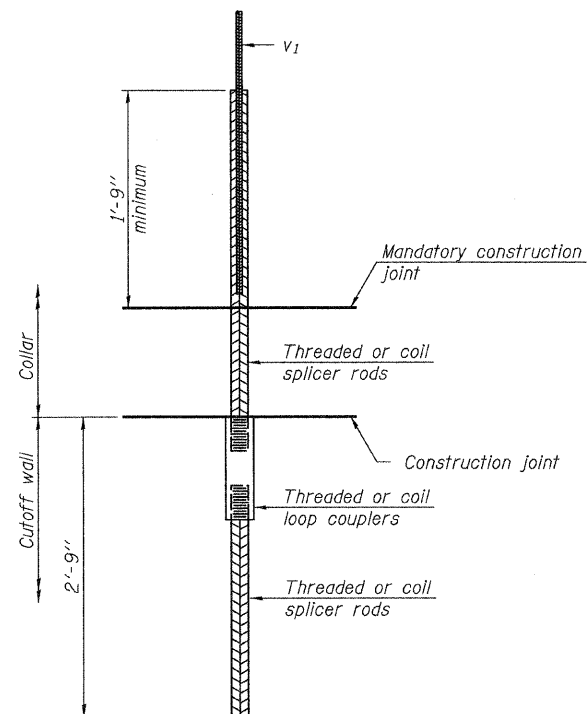

**FOR BOX CULVERT END SECTIONS**

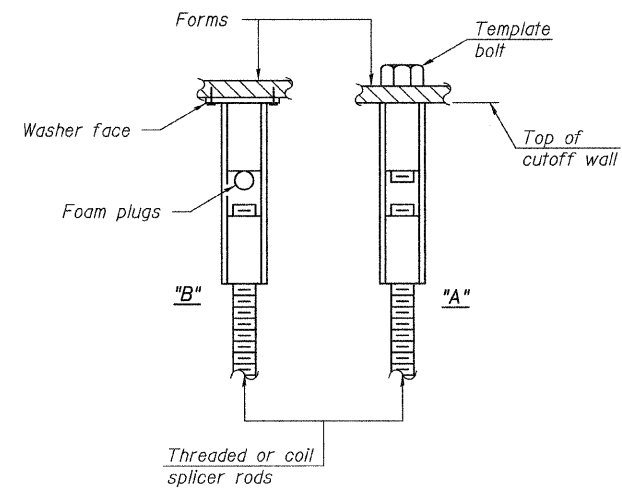

**INSTALLATION AND SETTING METHODS**

"A" : Set bar splicer assembly by means of a template bolt.  
 "B" : Set bar splicer assembly by nailing to wood forms or cementing to steel forms.

**NOTES**

Bar splicer assemblies shall be of an approved type and shall develop in tension at least 125 percent of the yield strength of the lapped reinforcement bars.  
 Splicer rods shall be of minimum 60 ksi yield strength, threaded or coiled full length.  
 All reinforcement bars shall be lapped and tied to the splicer rods or dowel bars.  
 Other systems of similar design may be submitted to the Engineer for approval. Approval shall be based on certified test results from an approved testing laboratory that the proposed bar splicer assembly satisfies the following requirements:

- ① Minimum Capacity =  $1.25 \times f_y \times A_s$   
 (Tension in kips)
  - ② Minimum \*Pull-out Strength =  $0.66 \times f_y \times A_s$   
 (Tension in kips)
- Where  $f_y$  = Yield strength of lapped reinforcement bars in ksi.  
 $A_s$  = Tensile stress area of lapped reinforcement bars.  
 \* = 28 day concrete

Bar Splicer for #5 bar	
Min. Capacity =	23.0 kips - tension
Min. Pull-out Strength =	12.3 kips - tension
No. Required =	24

**BAR SPLICER ASSEMBLY DETAILS**  
**IL. RTE. 84 OVER UNNAMED CREEK**  
**F.A.S. RTE. 5857 - SEC. 1R-T**  
**ROCK ISLAND COUNTY**  
**STATION 68+99.62**

DESIGNED - BAN	EXAMINED _____ DATE - ___	<b>STATE OF ILLINOIS DEPARTMENT OF TRANSPORTATION</b>	<b>BOX CULVERT END SECTION &amp; GABION WALL DETAILS</b>	F.A.S. RTE.	SECTION	COUNTY	TOTAL SHEETS	SHEET NO.
CHECKED - ---	ENGINEER OF BRIDGE DESIGN			5857	1R-T	ROCK ISLAND	25	16
DRAWN - TAC	PASSED _____			CONTRACT NO. 64E31				
CHECKED - ---	ENGINEER OF BRIDGES AND STRUCTURES			SHEET NO. 5 OF 5 SHEETS		ILLINOIS FED. AID PROJECT		



# BORING LOGS



**Illinois Department of Transportation**  
Division of Highways  
Illinois Department of Transportation/D-2

## SOIL BORING LOG

Page 1 of 1  
Date 7/10/08

ROUTE FAU 5857 DESCRIPTION P92-084-08 Culvert on IL 84, .6 m. N. of Colona Road LOGGED BY W. Garza

SECTION 1 R-T LOCATION Hampton Twp. - 4W1/2, SEC. , TWP. 17N, RNG. 1E

COUNTY Rock Island DRILLING METHOD Hollow Stem Auger HAMMER TYPE CME-45 Automatic

STRUCT. NO. Station	D E P T H	B L O W S	U C S	M O D E	Surface Water Elev. _____ ft	
					Stream Bed Elev. <u>583.10</u> ft	
BORING NO. Station Offset	(ft)	(1/8")	(tsf)	(%)	Groundwater Elev.: _____ ft	
					First Encounter _____ ft	Upon Completion _____ ft
Ground Surface Elev. <u>592.10</u> ft	After _____ Hrs. _____ ft					
STIFF black LOAM			1.0 P	15.0		
VERY LOOSE brown/black LOAM	590.10	2		16.0		
	588.60	2				
MEDIUM brown/tan LOAM		2				
	586.10	3 5	0.5 P	22.0		
VERY STIFF gray CLAY LOAM		2				
	583.10	3 5	2.7 B	19.0		
DENSE gray SHALE		10				
	581.10	21 12				
MEDIUM gray SHALE		9		17.0		
	578.60	9 12				
VERY DENSE gray SAND STONE		100/1"				
	576.10					
End of Boring						

The Unconfined Compressive Strength (UCS) Failure Mode is indicated by (B-Bulge, S-Shear, P-Penetrometer)  
The SPT (N value) is the sum of the last two blow values in each sampling zone (AASHTO T206)

BBS, from 137 (Rev. 8-99)



**Illinois Department of Transportation**  
Division of Highways  
Illinois Department of Transportation/D-2

## SOIL BORING LOG

Page 1 of 1  
Date 7/10/08

ROUTE FAU 5857 DESCRIPTION P92-084-08 Culvert on IL 84, .6 m. N. of Colona Road LOGGED BY W. Garza

SECTION 1 R-T LOCATION Hampton Twp. - 4W1/2, SEC. , TWP. 17N, RNG. 1E

COUNTY Rock Island DRILLING METHOD Hollow Stem Auger HAMMER TYPE CME-45 Automatic

STRUCT. NO. Station	D E P T H	B L O W S	U C S	M O D E	Surface Water Elev. _____ ft	
					Stream Bed Elev. <u>583.74</u> ft	
BORING NO. Station Offset	(ft)	(1/8")	(tsf)	(%)	Groundwater Elev.: _____ ft	
					First Encounter <u>584.2</u> ft	Upon Completion <u>584.2</u> ft
Ground Surface Elev. <u>591.20</u> ft	After _____ Hrs. _____ ft					
Road Rock						
MEDIUM dark gray LOAM	589.20	2		19.0		
	587.70	3	0.5 P			
STIFF brown LOAM with ROCKS		1				
	584.70	1 1	1.1 P	16.0		
SOFT gray CLAY LOAM/SHALE		0				
	582.70	0 1	0.5 B	32.0		
VERY DENSE gray SAND STONE		6				
	580.20		100/4"			
End of Boring						



The Unconfined Compressive Strength (UCS) Failure Mode is indicated by (B-Bulge, S-Shear, P-Penetrometer)  
The SPT (N value) is the sum of the last two blow values in each sampling zone (AASHTO T206)

BBS, from 137 (Rev. 8-99)

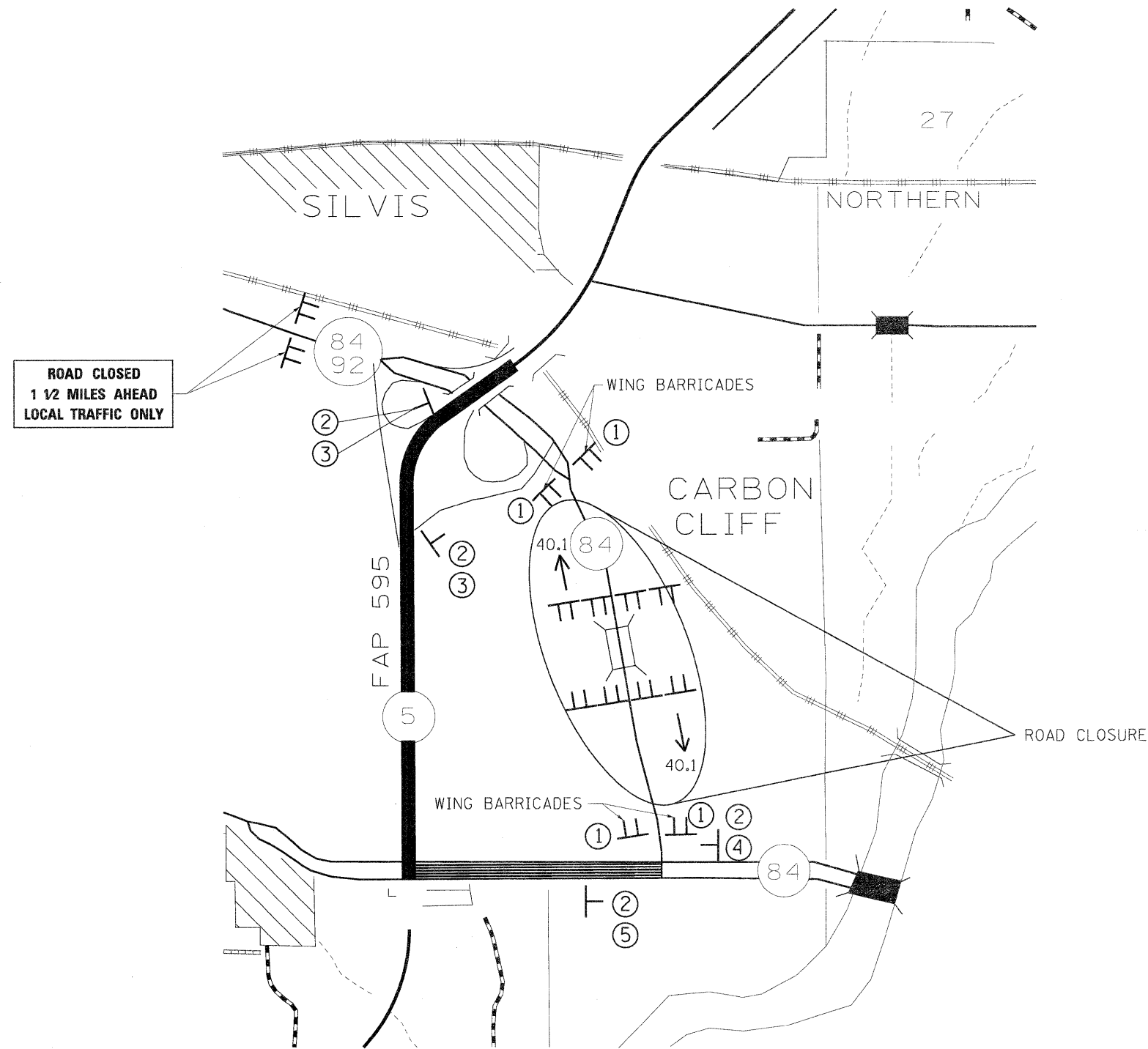



# DETOUR ROUTE

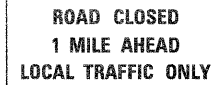

## LEGEND

-  DETOUR ROUTE
-  TYPE III BARRICADES WITH FLASHERS PLACED AS SHOWN IN STANDARD 701901.
-  ROAD CLOSED X MILE(S) SIGN WITH SUPPLEMENTAL PLATES AS REQUIRED IN THE SPECIAL PROVISIONS.

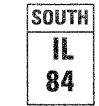
THIS SHALL BE PAID FOR AT THE CONTRACT UNIT PRICE PER LUMP SUM FOR TRAFFIC CONTROL FOR ROAD CLOSURE.

- ①  ROAD CLOSED 1 MILE AHEAD LOCAL TRAFFIC ONLY
- ②  ROAD CLOSED 1 MILE
- ③  SOUTH IL 84
- ④ 
- ⑤ 

FILE NAME =	USER NAME = cushmanbw	DESIGNED -	REVISED -
c:\pwork\pwork\cushmanbw\d0133431\0269400-shr-detail1.dgn		DRAWN -	REVISED -
PLOT SCALE = 50.0000 / / IN.		CHECKED -	REVISED -
PLOT DATE = Wed Oct 06 08:10:50 2010		DATE -	REVISED -

STATE OF ILLINOIS  
DEPARTMENT OF TRANSPORTATION

## DETOUR ROUTE

SCALE: SHEET NO. OF SHEETS STA. TO STA.

F.A.U. RTE.	SECTION	COUNTY	TOTAL SHEETS	SHEET NO.
5787	1R-T	ROCK ISLAND	25	18
				CONTRACT NO. 64E31
ILLINOIS FED. AID PROJECT				

# CURB AND GUTTER OUTLET, SPECIAL

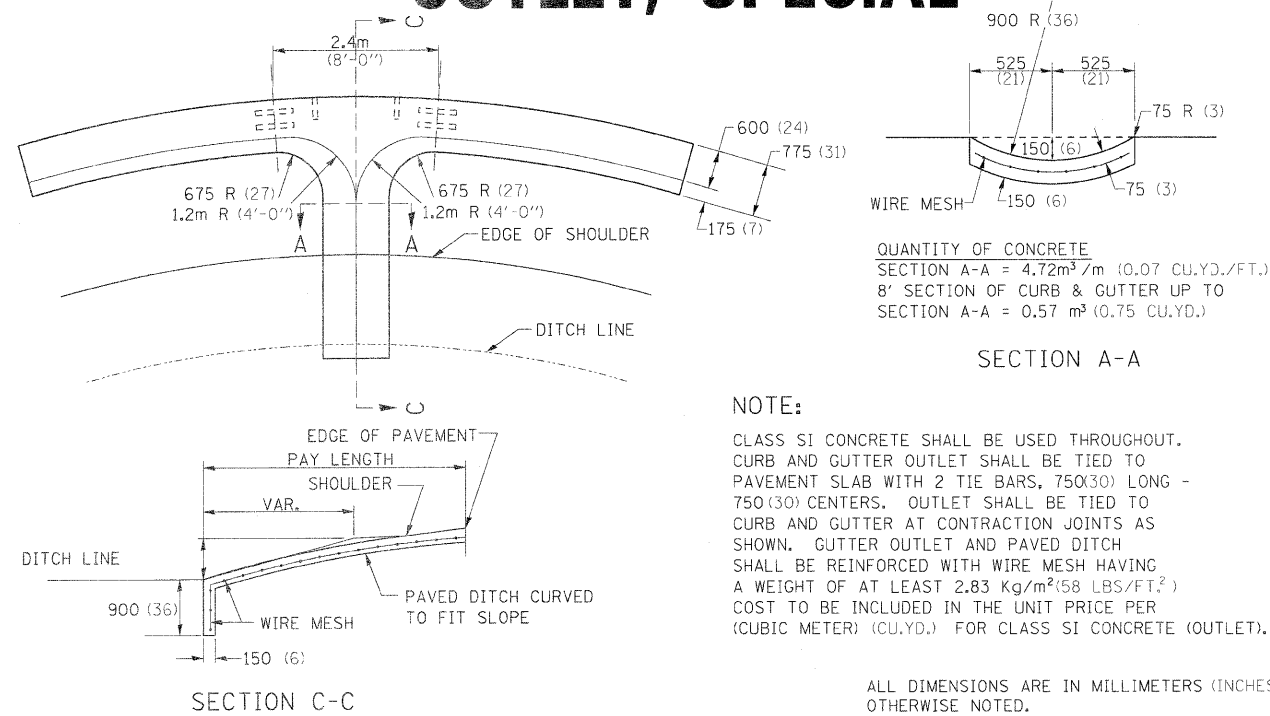

REVISED - 9-5-95

**CURB AND GUTTER OUTLET, SPECIAL 18.4**

# DELINEATOR AND POST ORIENTATION

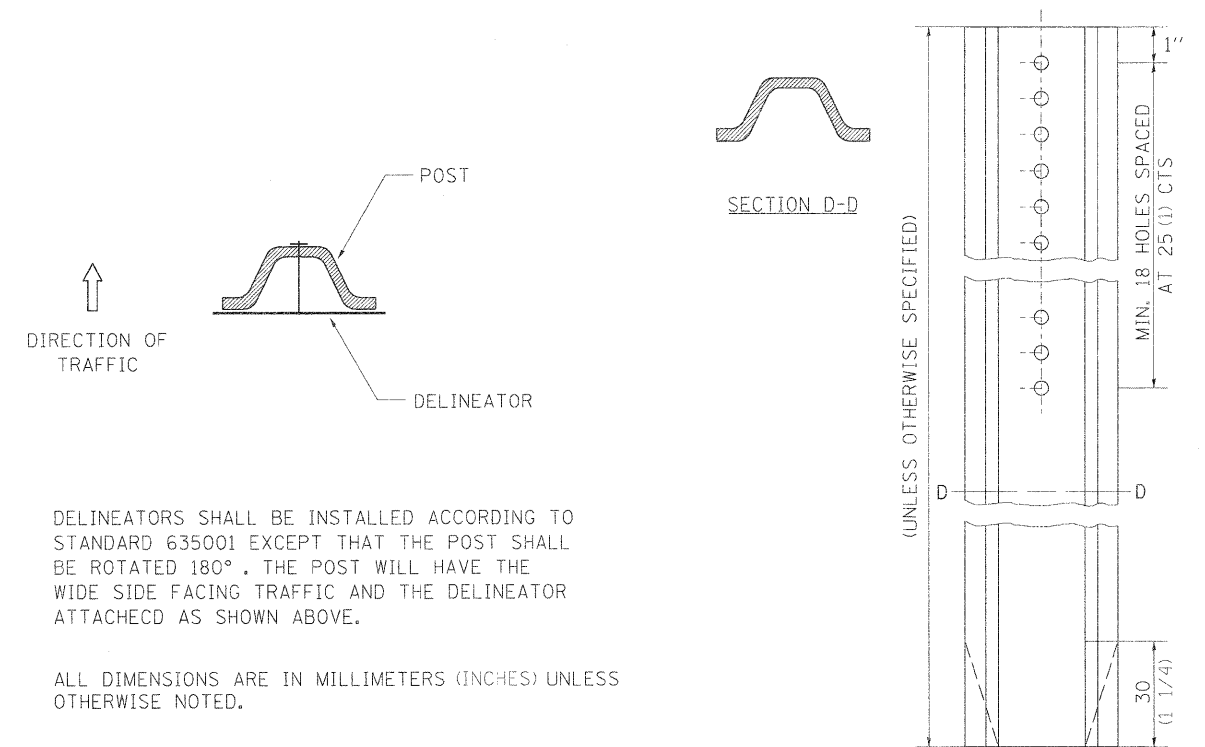

REVISED - 11-01-07

**DELINEATOR AND POST ORIENTATION 37.4**

REVISED -	<b>REGION 2 / DISTRICT 2 STANDARD</b>	F.A.U. RTE.	SECTION	COUNTY	TOTAL SHEETS	SHEET NO.
REVISED -		5787	IR-T	ROCK ISLAND	25	19
REVISED -		CONTRACT NO. 64E31				
REVISED -		SCALE: 50.0000' / 1" IN	SHEET NO.	OF	SHEETS	STA.

# WITNESS MARKER FOR PERMANENT SURVEY MARKERS, TYPE II

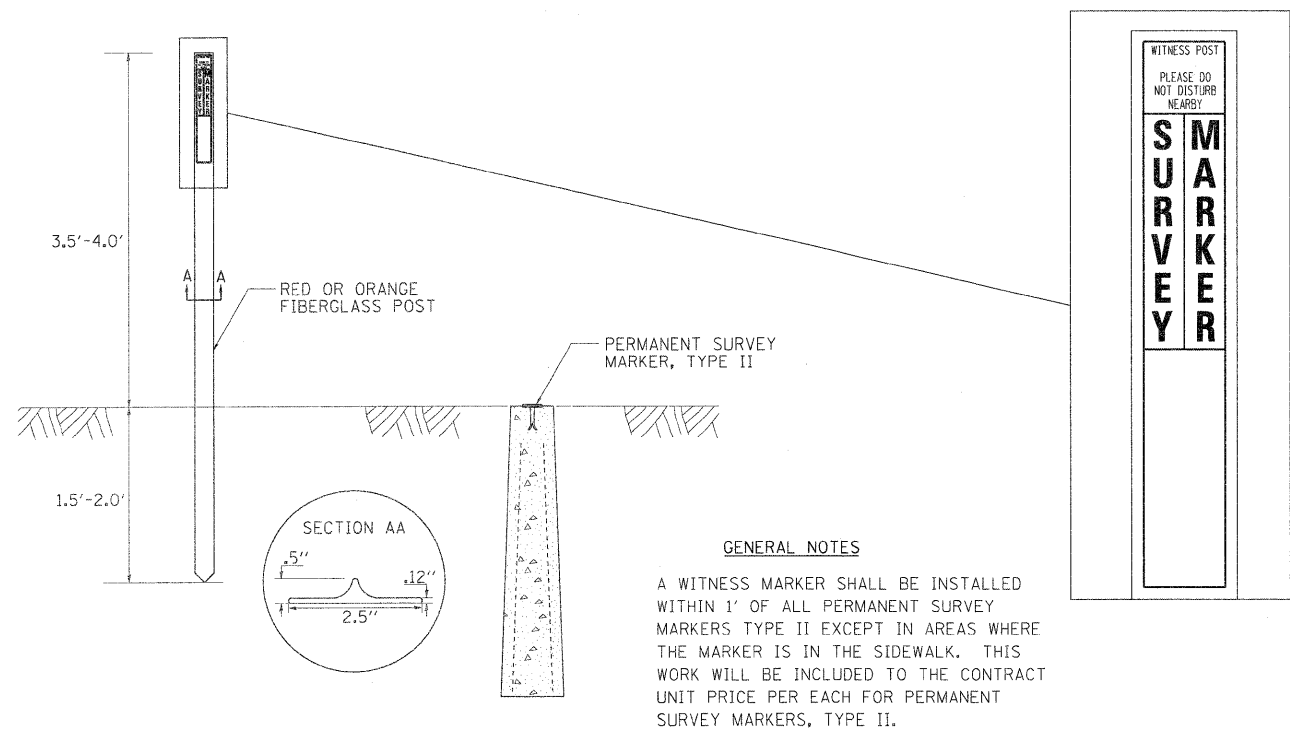

**GENERAL NOTES**  
 A WITNESS MARKER SHALL BE INSTALLED WITHIN 1' OF ALL PERMANENT SURVEY MARKERS TYPE II EXCEPT IN AREAS WHERE THE MARKER IS IN THE SIDEWALK. THIS WORK WILL BE INCLUDED TO THE CONTRACT UNIT PRICE PER EACH FOR PERMANENT SURVEY MARKERS, TYPE II.

# PERMANENT SURVEY MARKERS, TYPE II

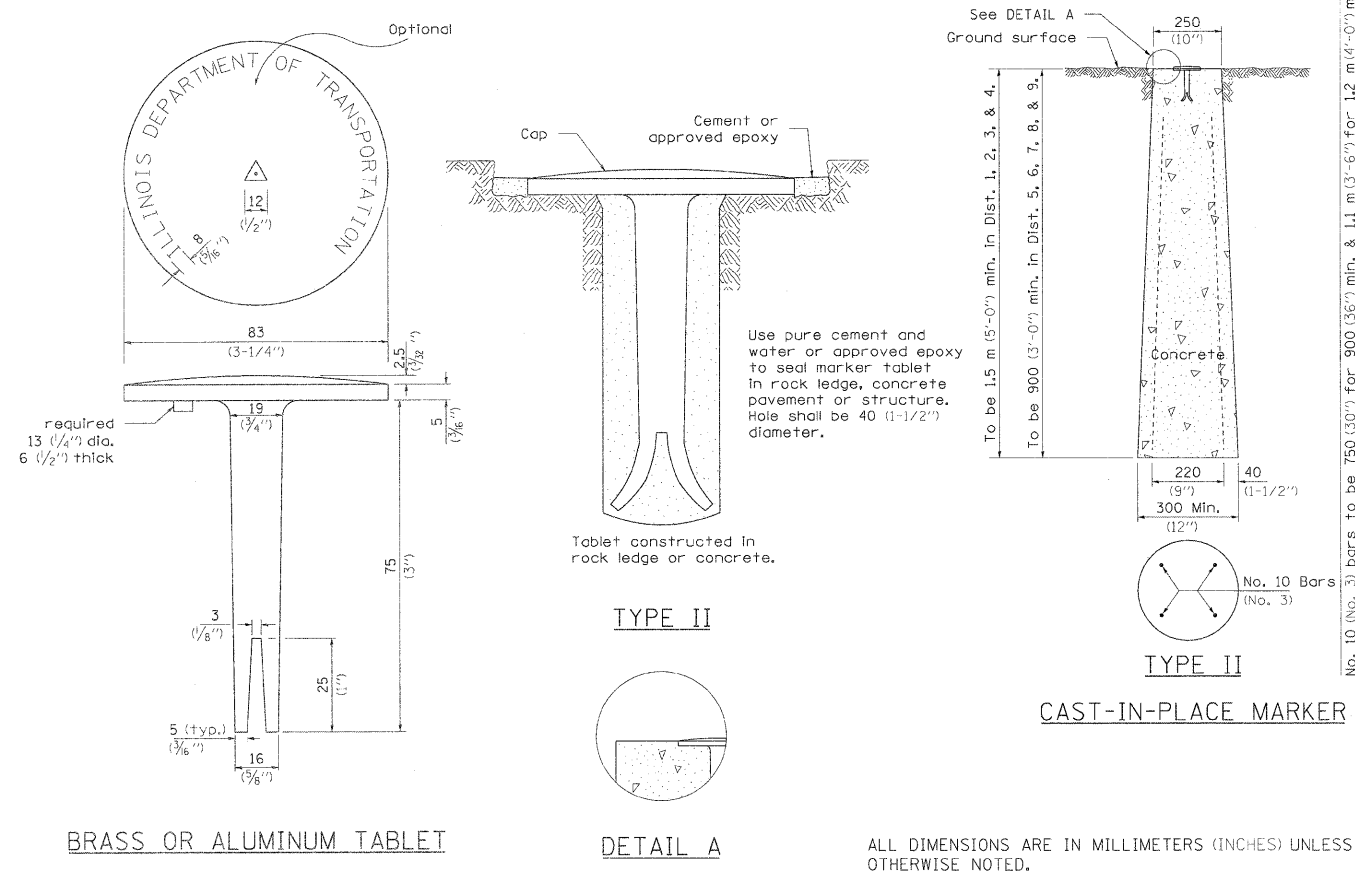

Use pure cement and water or approved epoxy to seal marker tablet in rock ledge, concrete pavement or structure. Hole shall be 40 (1-1/2)\"/>

ALL DIMENSIONS ARE IN MILLIMETERS (INCHES) UNLESS OTHERWISE NOTED.

# NAME PLATE FOR CULVERTS

FOR 24\"/>

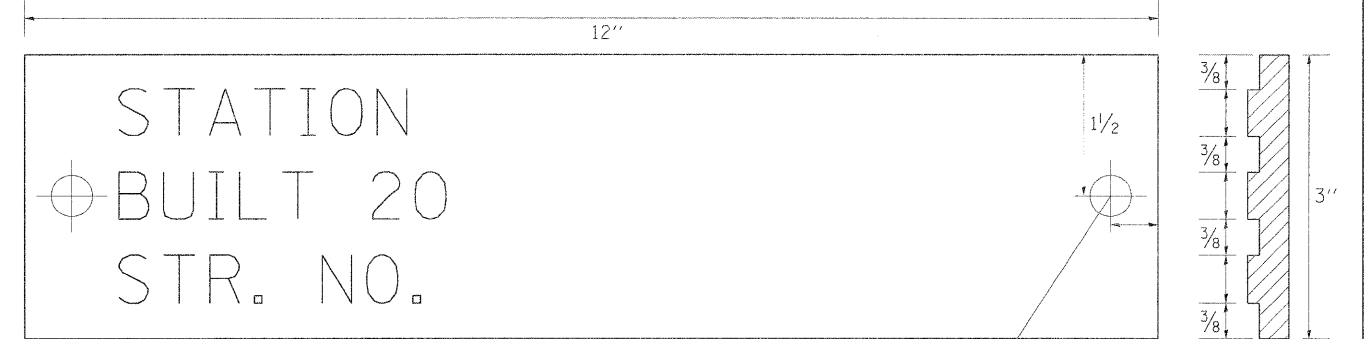

FOR 48\"/>



NOTE: LETTERING RAISED 1/8, SQUARE CUT AND NOT TAPERED

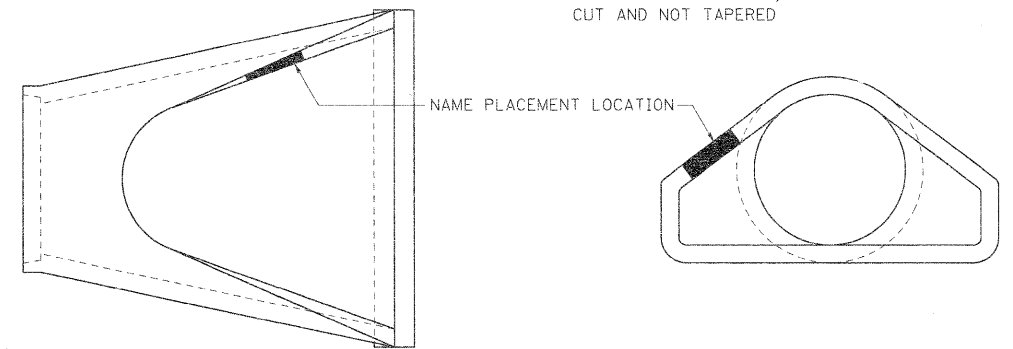

**DESIGNERS NOTE**

NAME PLATES SHALL BE FURNISHED & INSTALLED ACCORDING TO SECTION 515 OF THE STANDARD SPECIFICATIONS, EXCEPT 2 BOLTS SHALL BE USE TO FASTEN THE PLATE TO THE END SECTION.

USE STANDARD 515001 FOR BRIDGES AND MULTI-CELL CULVERTS WITH SPANS OF 20' OR MORE MEASURED ALONG THE CENTERLINE AT THE HIGHWAY.

USE THIS DETAIL FOR ALL OTHER PIPE CULVERTS & BOX CULVERTS WITH STRUCTURE NUMBERS. INCLUDE THE INFORMATION TO FILL OUT THE NAME PLATE FOR EACH CULVERT.

IN BOTH CASES INCLUDE A PAY ITEM FOR NAME PLATES.

STATION	STRUCTURE NO.
69+00	SN 081-1129

REVISED - 10-21-08

REVISED - 5-27-09

REGION 2 / DISTRICT 2 STANDARD  
 SCALE: 50.0000 1" = 10' SHEET NO. OF SHEETS STA. TO STA.

F.A.U. RTE.	SECTION	COUNTY	TOTAL SHEETS	SHEET NO.
5787	IR-T	ROCK ISLAND	25	20
CONTRACT NO. 64E31				
ILLINOIS FED. AID PROJECT				

# ENTRANCE APPROACHES – URBAN AREA

TYPICAL APPLICATION OF ENTRANCES

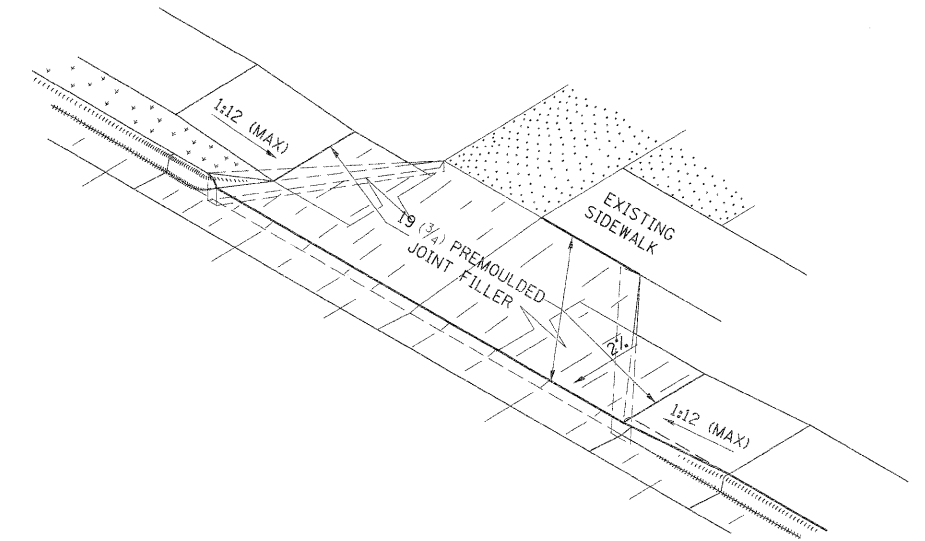
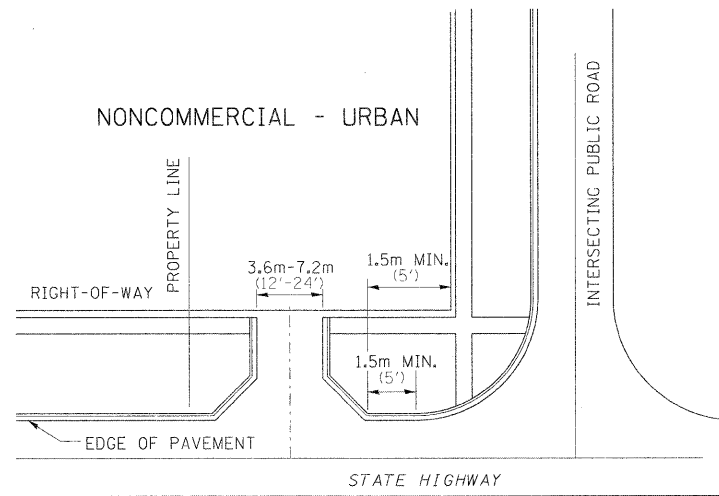
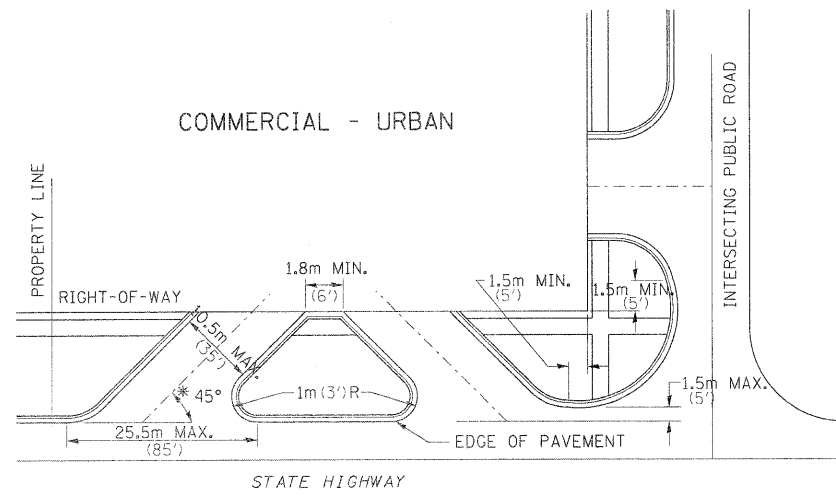

WHEN THE ISLAND BETWEEN DRIVES IS LESS THAN 7.5m (25') LONG OR LESS THAN 10 FEET WIDE, IT SHALL BE DEFINED BY CURBS, MASONRY, OR OTHER DEVICES.  
 \* 45° MIN. ANGLE PERMITTED ONLY FOR ONE-WAY DRIVEWAYS.  
 60° MIN. ANGLE FOR TWO-WAY DRIVEWAYS.

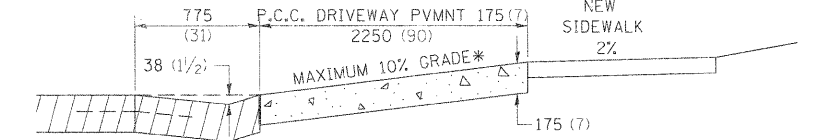
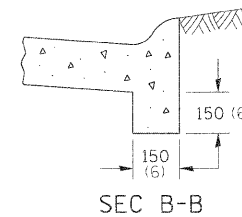
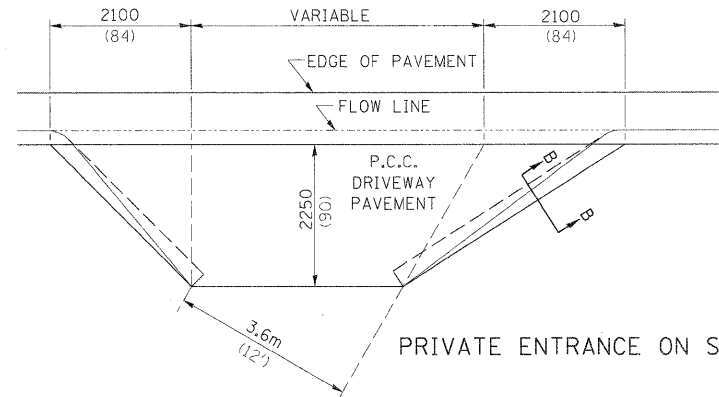
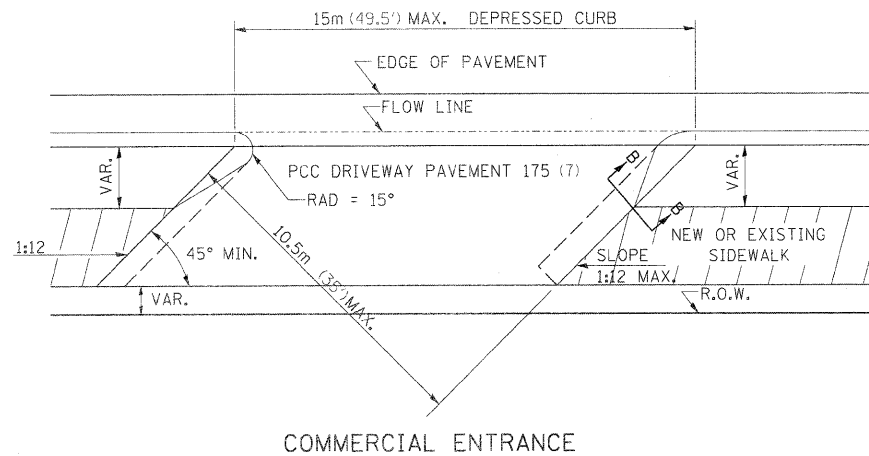

ASCENDING APPROACH

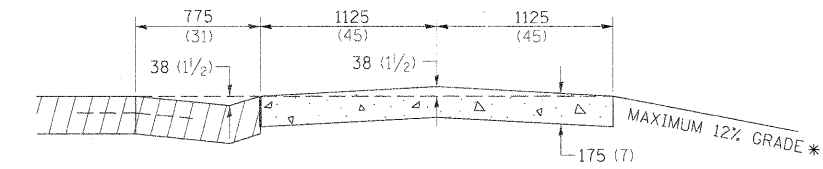

DESCENDING APPROACH

\* IN CASES WHERE GRADE EXCEEDS 10%, THE RESIDENT ENGINEER SHALL CHECK WITH DISTRICT DESIGN OFFICE TO DETERMINE NEW APPROACH GRADE, PARTICULAR ATTENTION SHALL BE PAID TO THE NEGATIVE GRADE TO PREVENT DRAINAGE FROM OVER FLOWING INTO THE PRIVATE ENTRANCE.

COMMERCIAL ENTRANCE

PRIVATE ENTRANCE ON SKEW

SECTION A-A

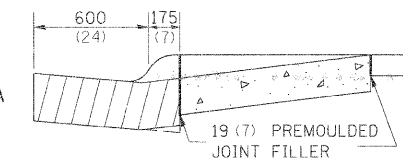

THE VARIABLE HEIGHT INTEGRAL CURB AND PREMOULDED JOINT FILLER WILL NOT BE PAID FOR SEPARATELY, BUT SHALL BE INCLUDED IN THE CONTRACT UNIT PRICE OF DRIVEWAY PAVEMENT OF THE THICKNESS SPECIFIED.

ALL DIMENSIONS ARE IN MILLIMETERS (INCHES) UNLESS OTHERWISE NOTED.

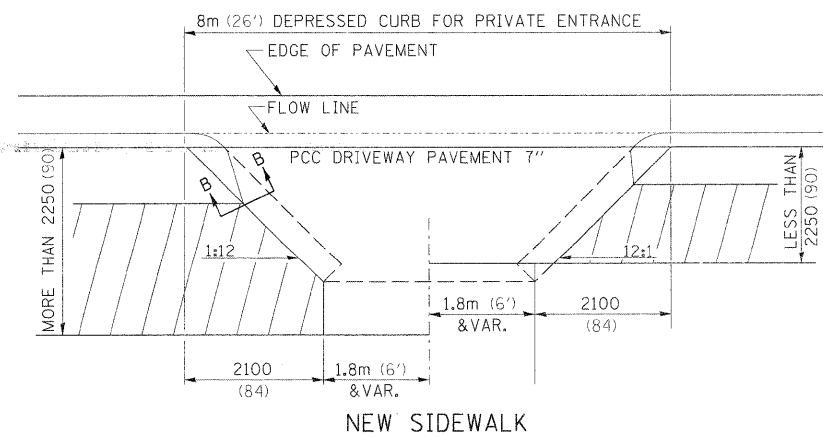
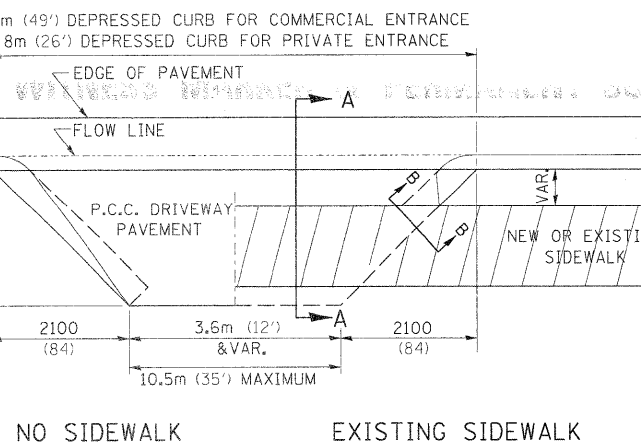

NEW SIDEWALK

FILE NAME =	USER NAME = cushmanbw	DESIGNED -	REVISED - 1-11-08	<b>STATE OF ILLINOIS DEPARTMENT OF TRANSPORTATION</b>	<b>REGION 2 / DISTRICT 2 STANDARD</b>			F.A.U. RTE.	SECTION	COUNTY	TOTAL SHEETS	SHEET NO.
cd:\pwork\pwork\cushmanbw\0133431\028408-shr-deta\ls.dgn	DRAWN -	REVISED -	F.5787					IR-T	ROCK ISLAND	25	21	
PLOT SCALE = 30.0000' / IN.	CHECKED -	REVISED -	CONTRACT NO. 64E31									
PLOT DATE = Wed Oct 06 08:11:41 2010	DATE -	REVISED -	ILLINOIS FED. AID PROJECT									
					SCALE:	SHEET NO.	OF	SHEETS	STA.	TO STA.		

# TRAFFIC CONTROL FOR ROAD CLOSURE

## CONDITION II

Minor Sideroad Closure

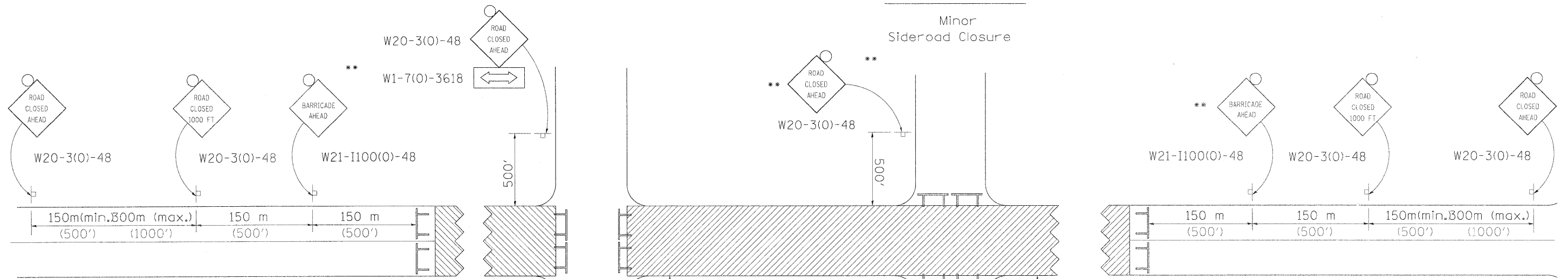

## CONDITION I

Major Sideroad Closure

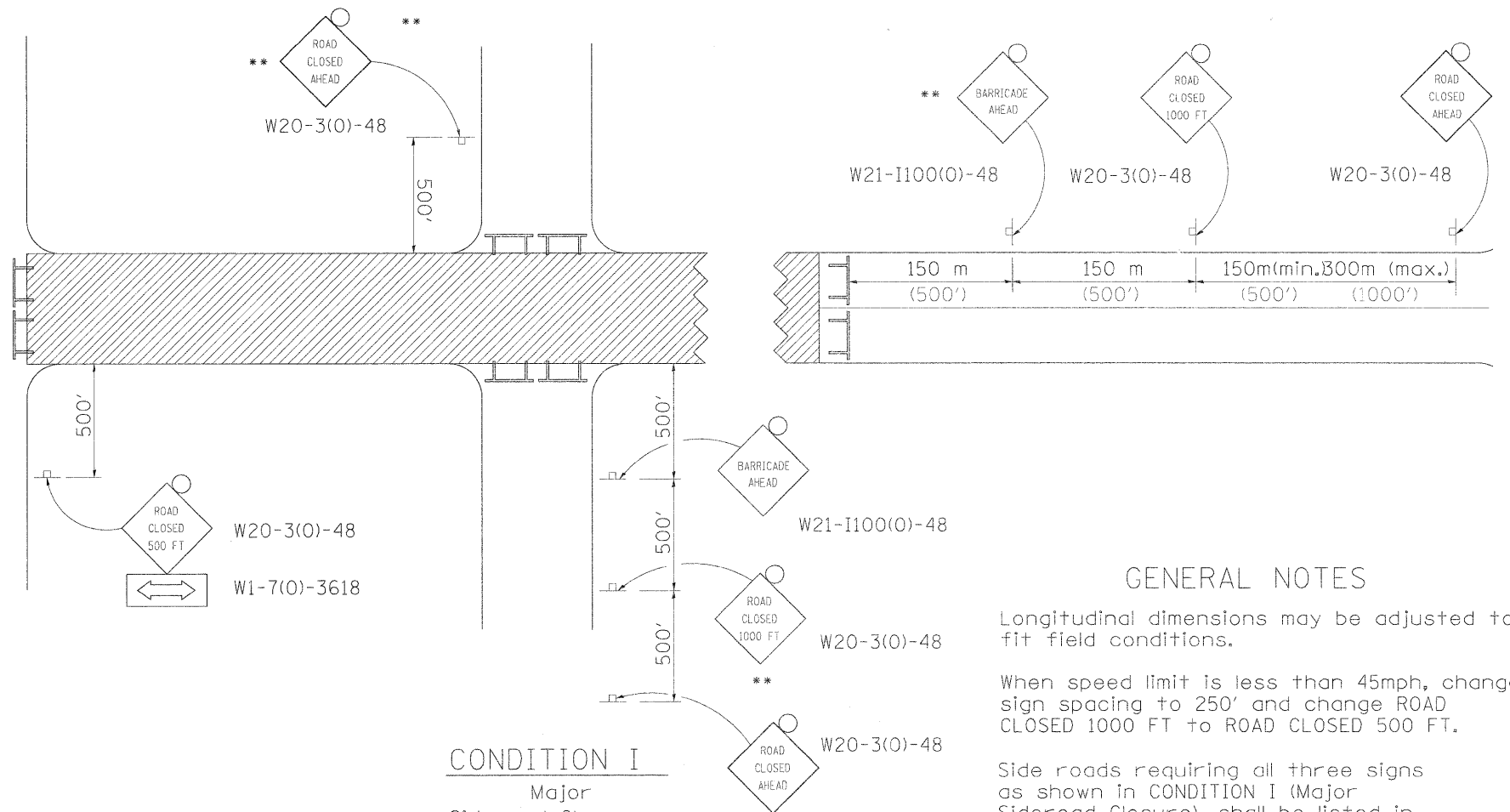

### GENERAL NOTES

Longitudinal dimensions may be adjusted to fit field conditions.

When speed limit is less than 45mph, change sign spacing to 250' and change ROAD CLOSED 1000 FT to ROAD CLOSED 500 FT.

Side roads requiring all three signs as shown in CONDITION I (Major Sideroad Closure), shall be listed in the special provision.

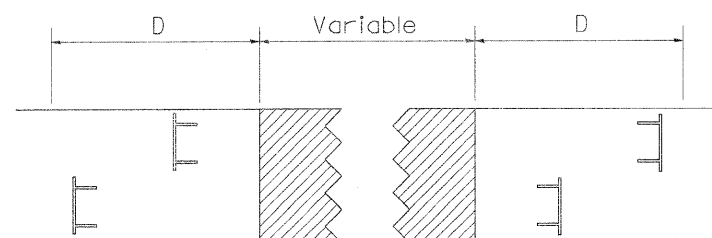

\*\* Where local access is to be maintained, barricades are to be set up as shown in Road Closed to thru traffic. Type III Barricades and R11-2-4830 signs shall be as shown in "Road Closed To All Traffic" detail on Highway Standard 701901.

### ROAD CLOSED TO THRU TRAFFIC BARRICADE SET UP

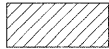

Type III Barricades and R11-4-4830 signs shall be as shown in "Road Closed To All Thru Traffic" detail on Highway Standard 701901. If the distance "D" exceeds 600 m (2000') an additional set of barricades and R11-4-4830 shall be placed at each end of the work area.

### SYMBOLS

-  Work area
-  Type III Barricade with Flashers
-  Sign with flashing light

All dimensions are in millimeters (inches) unless otherwise shown.

### TYPICAL APPLICATION FOR ROAD CLOSURE

FILE NAME =	USER NAME = cushmanbw	DESIGNED -	REVISED - 1-11-08	<b>STATE OF ILLINOIS DEPARTMENT OF TRANSPORTATION</b>	<b>REGION 2 / DISTRICT 2 STANDARD</b>			F.A.U. RTE.	SECTION	COUNTY	TOTAL SHEETS	SHEET NO.
c:\pwwork\pwwork\cushmanbw\01133431\0268408-shr-detail1.s.dgn		DRAWN -	REVISED -					5787	IR-T	ROCK ISLAND	25	22
		CHECKED -	REVISED -		CONTRACT NO. 64E31							
		DATE = Wed Oct 06 08:11:52 2010	REVISED -		SCALE:	SHEET NO.	OF SHEETS	STA.	TO STA.	FED. ROAD DIST. NO.	ILLINOIS FED. AID PROJECT	

# DETAILS OF PLANTING AND BRACING TREES

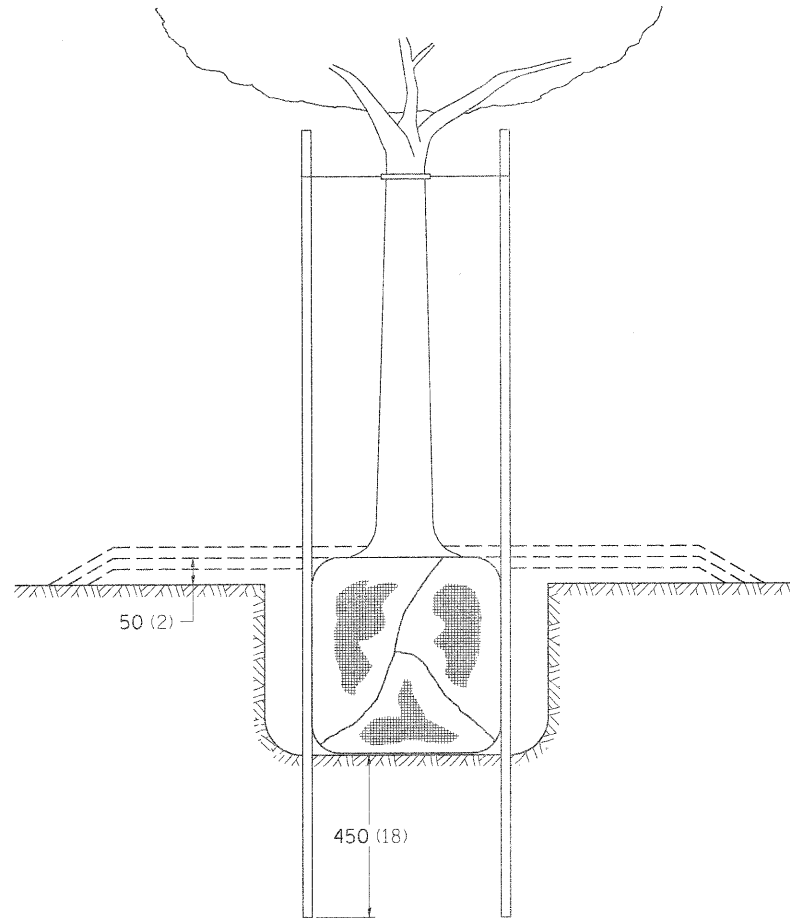

TREES SMALLER THAN 115 (4 1/2) IN DIAMETER

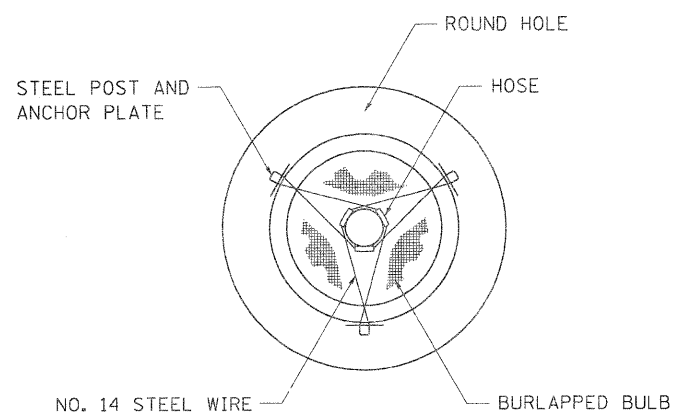

SMALL	A	B	C	D	E	F
TREE SIZE	DIAMETER OF BALL OR ROOT SYS.	DEPTH OF HOLE EXCAVATION	WIDTH OF HOLE EXCAVATION	THICKNESS OF MULCH COVER	DEPTH OF BALL OR ROOT SYS.	VOLUME OF MULCH COVER m <sup>3</sup> (CU. YDS.)
1.5-1.8m (5'-6')	400 (16)	250 (10)	750 (30)	100 (4)	300 (12)	0.41 (0.54)
1.5-1.8m (5'-6') BB	400 (16)	250 (10)	750 (30)	100 (4)	300 (12)	0.41 (0.54)
1.8-2.0m (6'-7') BB	450 (18)	300 (12)	750 (30)	100 (4)	350 (14)	0.41 (0.54)
2.0-2.4m (7'-8') BB	500 (20)	275 (11)	750 (30)	100 (4)	325 (13)	0.41 (0.54)
2.4-3.0m (8'-10') BB	600 (24)	350 (14)	900 (36)	100 (4)	400 (16)	0.47 (0.61)
3.0-3.6m (10'-12') BB	650 (26)	375 (15)	900 (36)	100 (4)	425 (17)	0.47 (0.61)

LARGE	A	B	C	D	E	F
TREE SIZE	DIAMETER OF BALL OR ROOT SYS.	DEPTH OF HOLE EXCAVATION	WIDTH OF HOLE EXCAVATION	THICKNESS OF MULCH COVER	DEPTH OF BALL OR ROOT SYS.	VOLUME OF MULCH COVER m <sup>3</sup> (CU. YDS.)
0-50 (0-2)	500 (20)	275 (11)	900 (36)	100 (4)	325 (13)	0.47 (0.61)
50-65 (2-2 1/2) BB	600 (24)	350 (14)	1200 (48)	100 (4)	400 (16)	0.60 (0.78)
65-75 (2 1/2-3) BB	700 (28)	425 (17)	1200 (48)	100 (4)	475 (19)	0.60 (0.78)
75-90 (3-3 1/2) BB	800 (32)	425 (17)	1500 (60)	100 (4)	475 (19)	0.73 (0.96)
90-100 (3 1/2-4) BB	900 (36)	500 (20)	1500 (60)	100 (4)	550 (22)	0.73 (0.96)
100-115 (4-4 1/2) BB	1000 (40)	550 (22)	1800 (72)	100 (4)	600 (24)	0.89 (1.16)
115-125 (4 1/2-5) BB	1100 (44)	600 (24)	1800 (72)	100 (4)	650 (26)	0.89 (1.16)
125-140 (5-5 1/2) BB	1200 (48)	675 (27)	2100 (84)	100 (4)	725 (29)	1.06 (1.38)

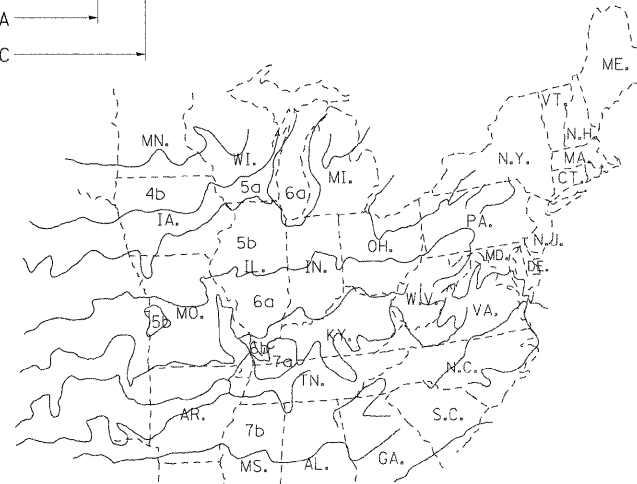
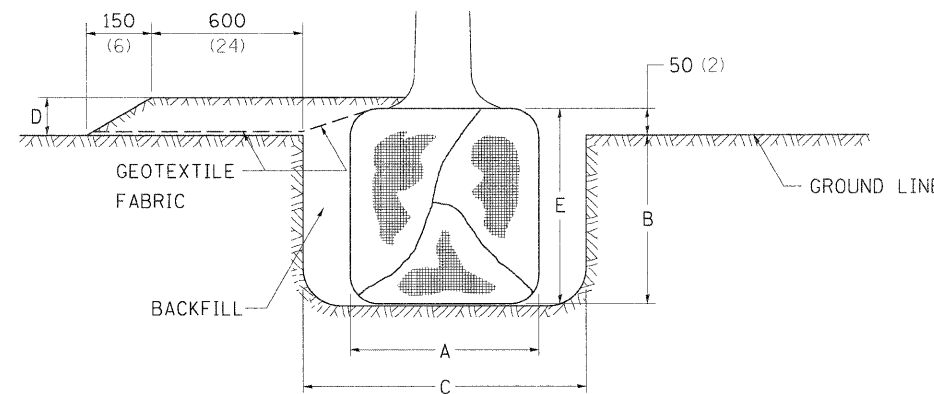

PLANT HARDINESS ZONE MAP  
U.S. DEPARTMENT OF AGRICULTURE  
AGRICULTURAL RESEARCH SERVICE  
PUBLICATION NO. 814

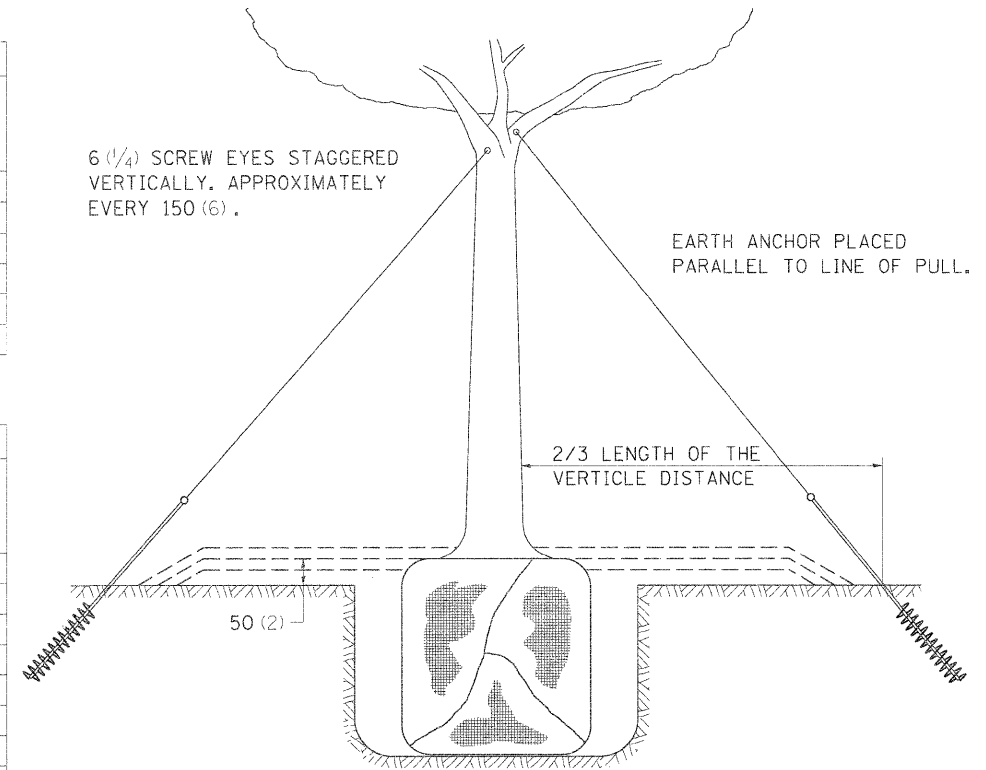

TREES OVER 115 (4 1/2) IN DIAMETER

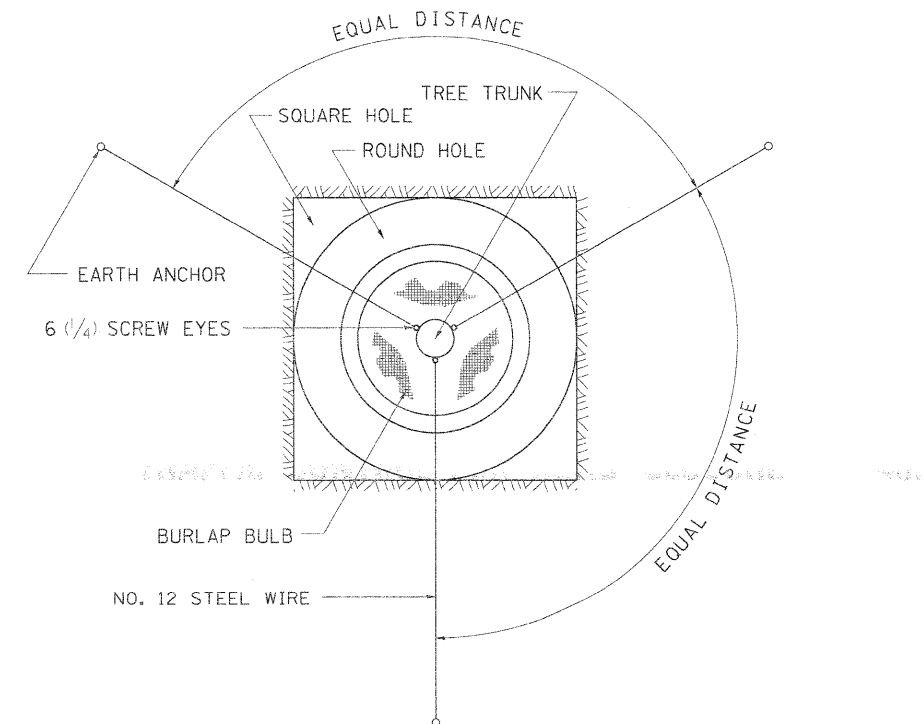

ALL DIMENSIONS ARE IN MILLIMETERS (INCHES)  
UNLESS OTHERWISE NOTED.

FILE NAME =	USER NAME = cushmanbw	DESIGNED -	REVISED - 10-15-04	<b>STATE OF ILLINOIS DEPARTMENT OF TRANSPORTATION</b>	<b>REGION 2 / DISTRICT 2 STANDARD</b>	F.A.U. RTE.	SECTION	COUNTY	TOTAL SHEETS	SHEET NO.
c:\pw\work\pws\dct\cushmanbw\08133431\0228408-shr-det-1.dgn	DRAWN -	REVISED -	5787			IR-T	ROCK ISLAND	25	23	
PLDT SCALE = 50.0000' / IN.	CHECKED -	REVISED -	CONTRACT NO. 64E31							
PLDT DATE = Wed Oct 06 08:12:04 2010	DATE -	REVISED -	FED. ROAD DIST. NO. ILLINOIS FED. AID PROJECT							

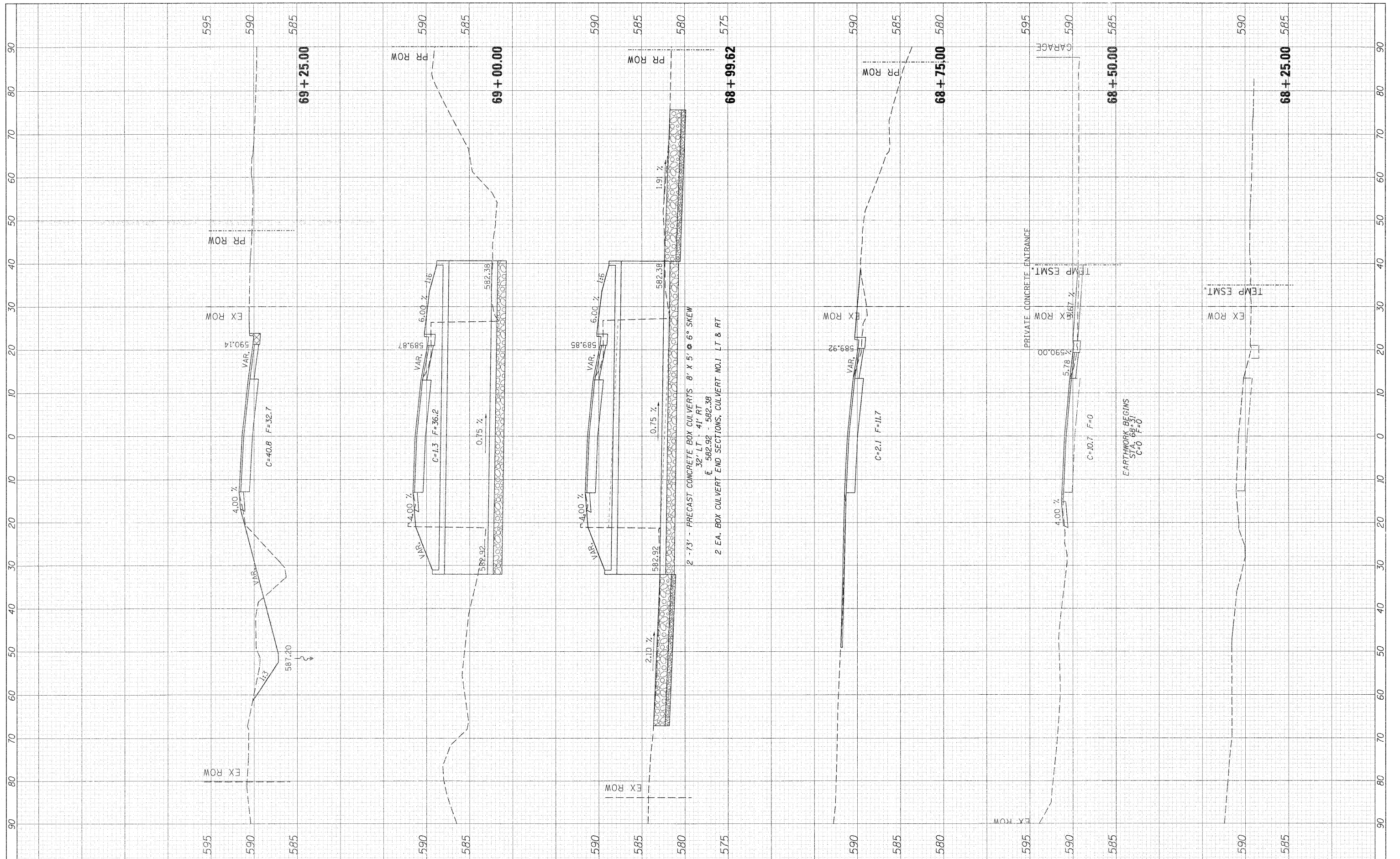

STATE OF ILLINOIS  
DEPARTMENT OF TRANSPORTATION

IL 84 CROSS SECTIONS

FILE NAME =  
c:\pwwork\pwwork\cushmenibw\id0133457\0208408-1\11.dgn

USER NAME = cushmenibw  
PLOT SCALE = 10.0000' / IN.  
PLOT DATE = Wed Oct 06 08:57:42 2010

DESIGNED -  
DRAWN -  
CHECKED -  
DATE -

REVISED -  
REVISED -  
REVISED -  
REVISED -

SCALE: SHEET NO. OF SHEETS STA. 68+25.00 TO STA. 69+00.00

F.A.U. RTE.	SECTION	COUNTY	TOTAL SHEETS	SHEET NO.
5857	1R-T	ROCK ISLAND	25	24
CONTRACT NO. 64E31				
ILLINOIS FED. AID PROJECT				



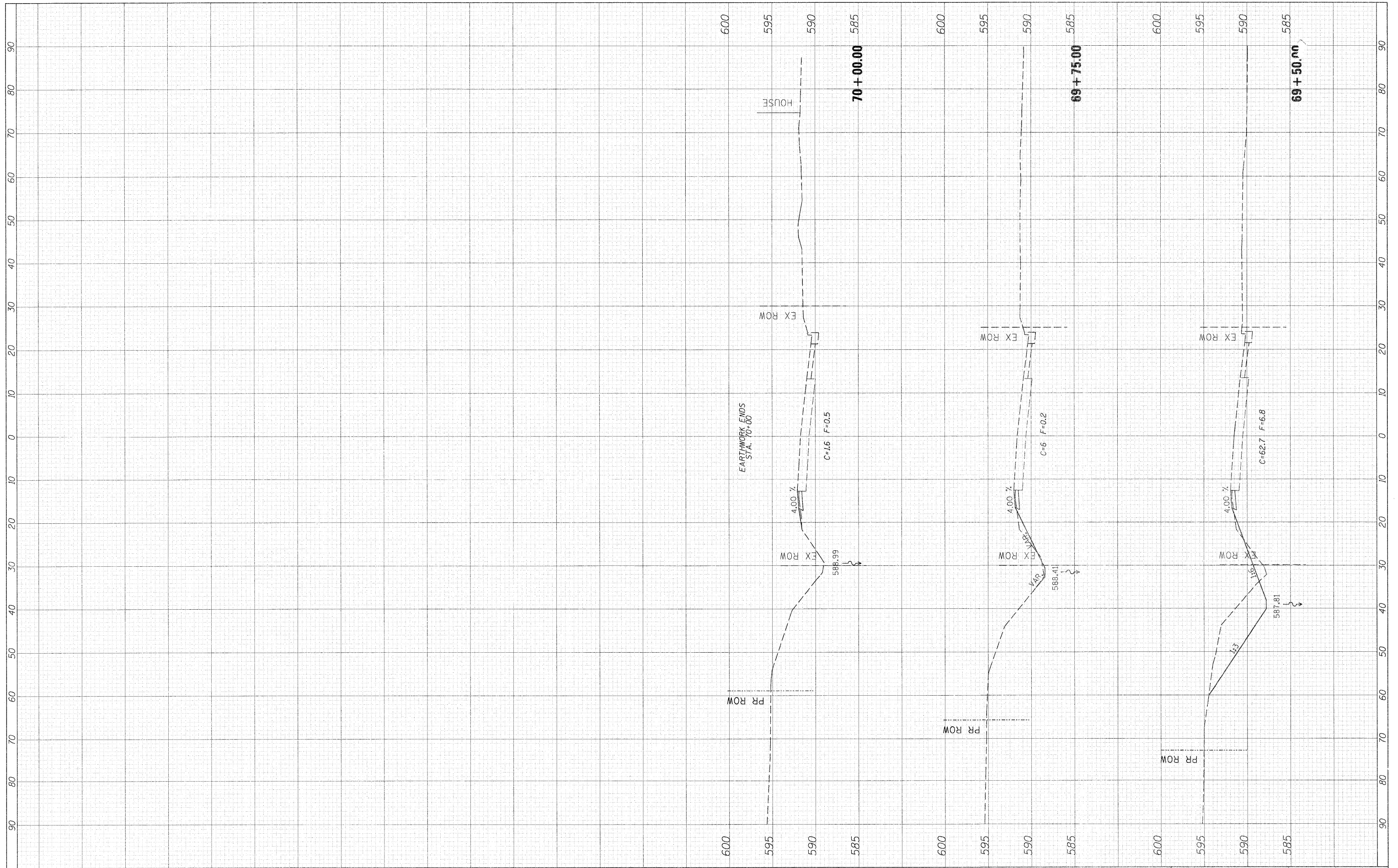

FILE NAME \*  
 c:\pwwork\pki\dot\cushmanbw\0133457\0288408\pki\m.dgn

USER NAME \* cushmanbw  
 DESIGNED -  
 DRAWN -  
 CHECKED -  
 DATE -  
 PLOT SCALE = 10.0000' / IN.  
 PLOT DATE = Wed Oct 06 08:57:58 2010

DESIGNED -  
 DRAWN -  
 CHECKED -  
 DATE -

REVISED -  
 REVISED -  
 REVISED -  
 REVISED -

STATE OF ILLINOIS  
 DEPARTMENT OF TRANSPORTATION

IL 84 CROSS SECTIONS

SCALE: SHEET NO. OF SHEETS STA. 69+98.00 TO STA. 70+06.00

F.A.U. RTE.	SECTION	COUNTY	TOTAL SHEETS	SHEET NO.
5857	1R-T	ROCK ISLAND	25	25
CONTRACT NO. 64E31				
ILLINOIS FED. AID PROJECT				