

**MILLING LIMITS AT SIDE STREETS**

NOTE: THESE LIMITS ARE FOR THE FOLLOWING SIDESTREETS:  
 PIKE STREET (NORTH SIDE ONLY)  
 FULTON STREET (SOUTH SIDE ONLY)  
 WALNUT STREET (NORTH SIDE ONLY)  
 BUCKLIN STREET (NORTH AND SOUTH SIDES)  
 TONTI STREET (SOUTH SIDE ONLY)  
 LAHHARPE (NORTH SIDE ONLY)

ON ALL OTHER SIDE STREETS, MILL BACK TO RADIUS RETURNS

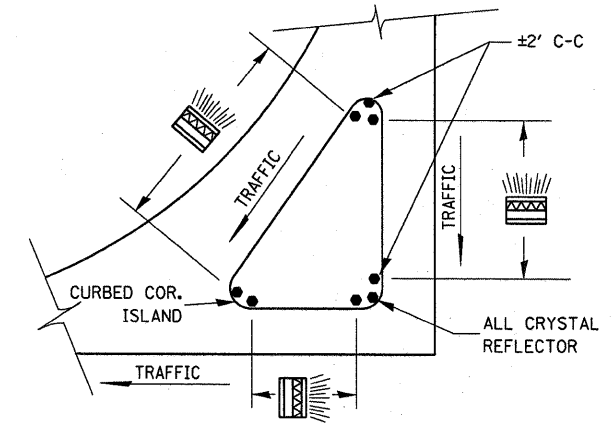

**PRISMATIC REFLECTORS**

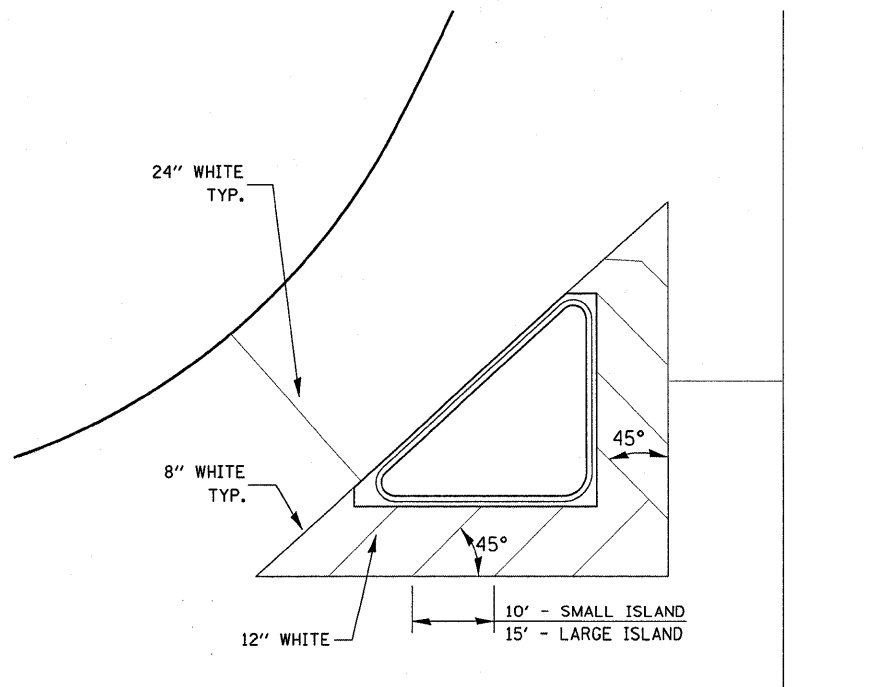

**TYPICAL ISLAND**

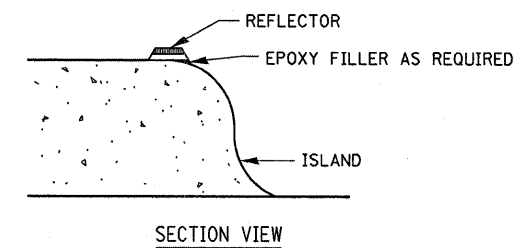
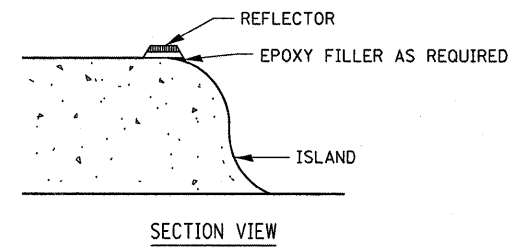

**NOTES**

1. PRISMATIC REFLECTORS SHALL BE MONO-DIRECTIONAL AND POSITIONED SO THAT THE REFLECTIVE FACE IS FACING THE APPROACHING TRAFFIC.
2. PRISMATIC REFLECTORS SHALL BE SECURED IN PLACE WITH AN EPOXY ADHESIVE.
3. PRISMATIC REFLECTORS SHALL BE EITHER AMBER OR CRYSTAL IN COLOR.

FILE NAME =	USER NAME = braboypa	DESIGNED -	REVISED -	<b>STATE OF ILLINOIS DEPARTMENT OF TRANSPORTATION</b>	<b>DETAILS</b>	F.A.P. RTE.	SECTION	COUNTY	TOTAL SHEETS	SHEET NO.	
c:\pwork\pwork\braboypa\d8173862\d36810-sht-details.dgn		DRAWN -	REVISED -			623	17RS-3; 33RS-5; (34R)RS	*	55	47	
PLOT SCALE = 50.0000' / IN.		CHECKED -	REVISED -			CONTRACT NO. 66A10					
PLOT DATE = Feb 10, 2011 - 02:49:27 PM		DATE -	REVISED -			ILLINOIS FED. AID PROJECT • BUREAU/LASALLE					
					SCALE:	SHEET NO. OF SHEETS		STA. TO STA.			