

PROPOSED TYPICAL SECTION
STA. 6+80.00 TO STA. 13+57.57

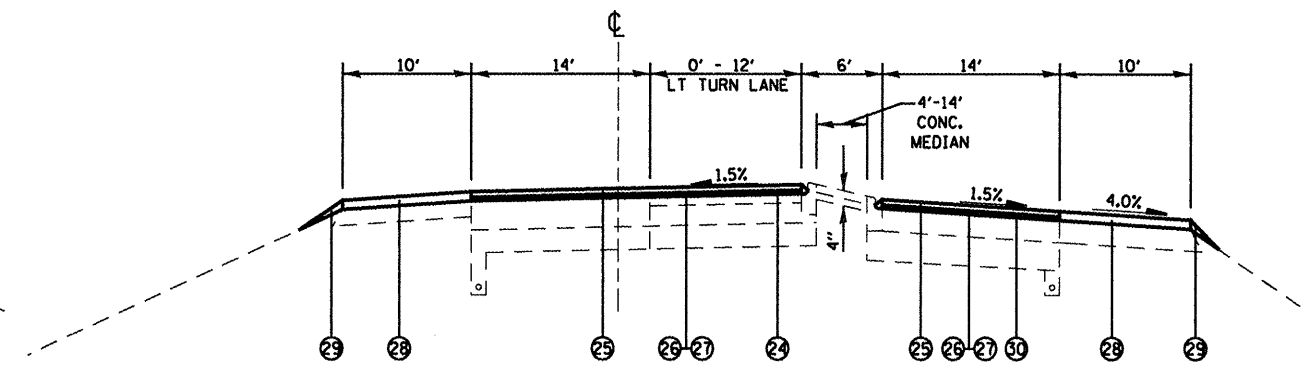

PROPOSED TYPICAL SECTION
STA. 16+66.82 TO STA. 20+09.25

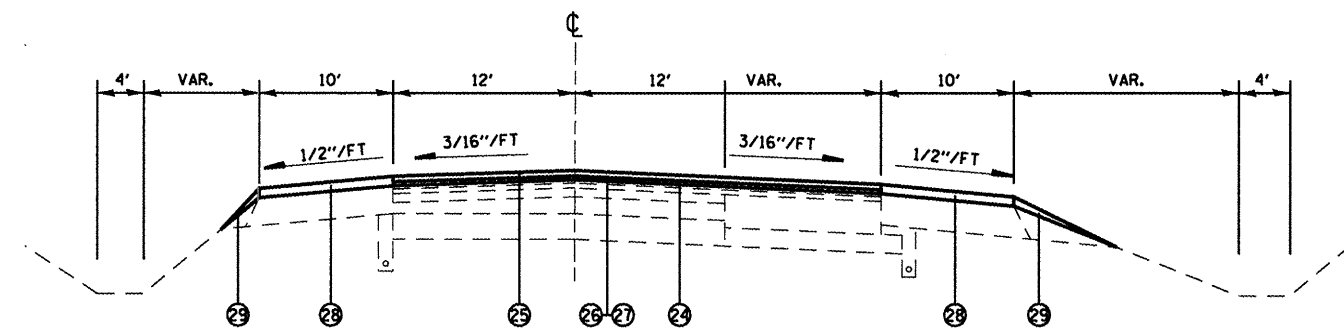

PROPOSED TYPICAL SECTION
STA. 13+57.57 TO STA. 14+52.43

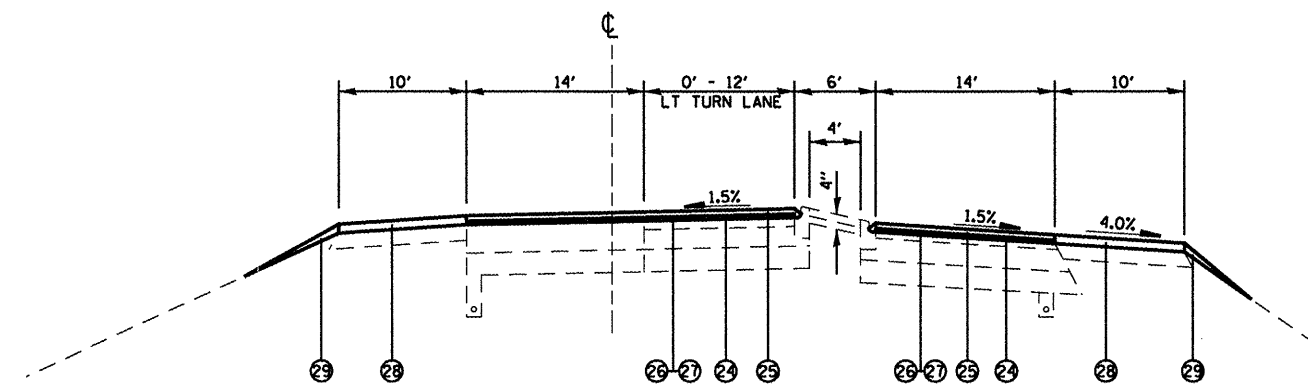

PROPOSED TYPICAL SECTION
STA. 14+52.00 TO STA. 16+66.82

LEGEND

- 24 PROPOSED LEVELING BINDER (MACHINE METHOD), N70, 3/4"
- 25 PROPOSED POLY HMA SRFCR CRSE, MIX "D", N70, 1 1/2"
- 26 PROPOSED BITUMINOUS MATERIAL (PRIME COAT)
- 27 PROPOSED AGGREGATE (PRIME COAT)
- 28 PROPOSED HMA SHOULDER
- 29 PROPOSED AGGREGATE WEDGE SHOULDER
- 30 PROPOSED LEVELING BINDER (MACHINE METHOD), N70, 1"

FILE NAME =	USER NAME = #USER#	DESIGNED -	REVISED -
#FILE#		DRAWN -	REVISED -
	PLDT SCALE = #SCALE#	CHECKED -	REVISED -
	PLDT DATE = #DATE#	DATE -	REVISED -

STATE OF ILLINOIS
DEPARTMENT OF TRANSPORTATION

PROPOSED TYPICAL SECTION LOCATION #2
IL 162 @ 1255

F.A.P. RTE.	SECTION	COUNTY	TOTAL SHEET NO.
586	5785-4157-1.5185-3	MADISON	33 12
			CONTRACT NO. 78E49
FED. ROAD DIST. NO. ILLINOIS FED. AID PROJECT			

SCALE: SHEET NO. OF SHEETS STA. TO STA.