

SECTION A-A

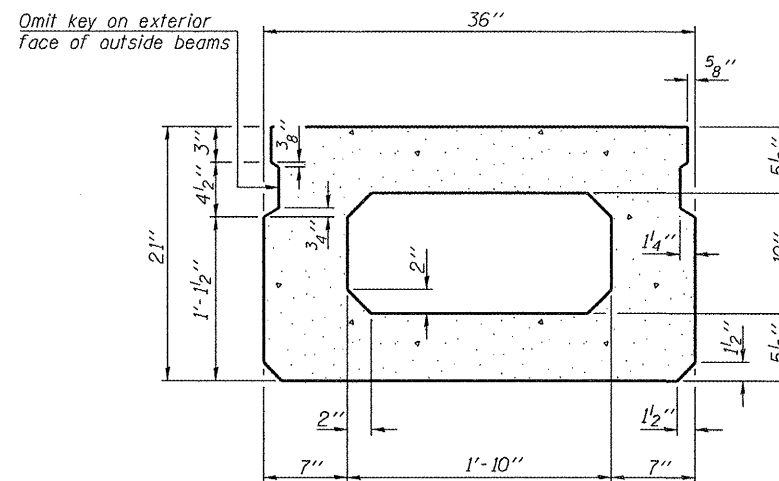

SECTION B-B
(Showing dimensions)

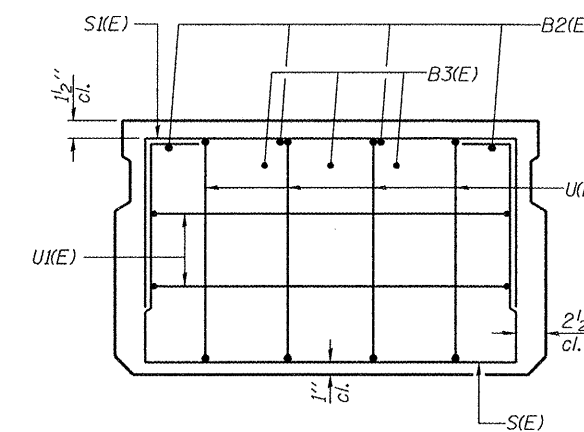

VIEW C-C

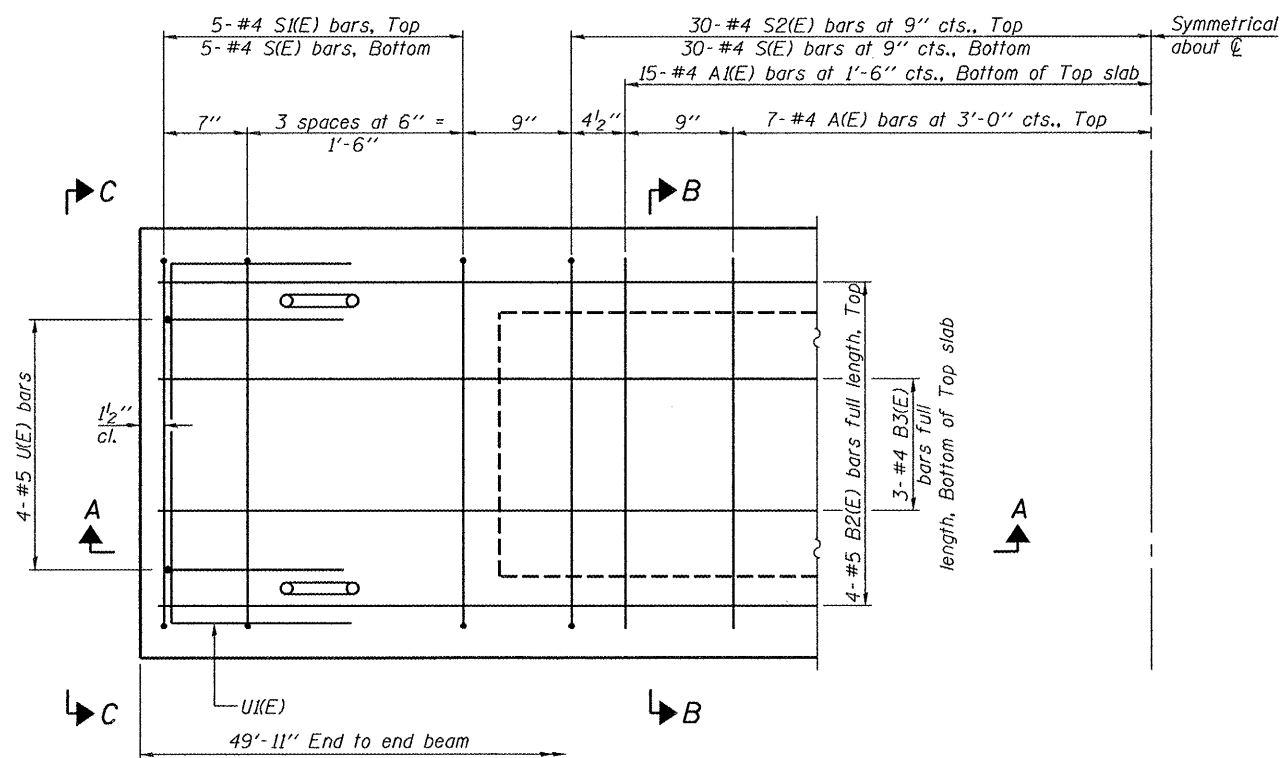

PLAN VIEW

Note: Spacing of S(E) and S2(E) bars may be adjusted up to 4" in the immediate area of the transverse tie diaphragms to miss the block outs for the transverse ties.

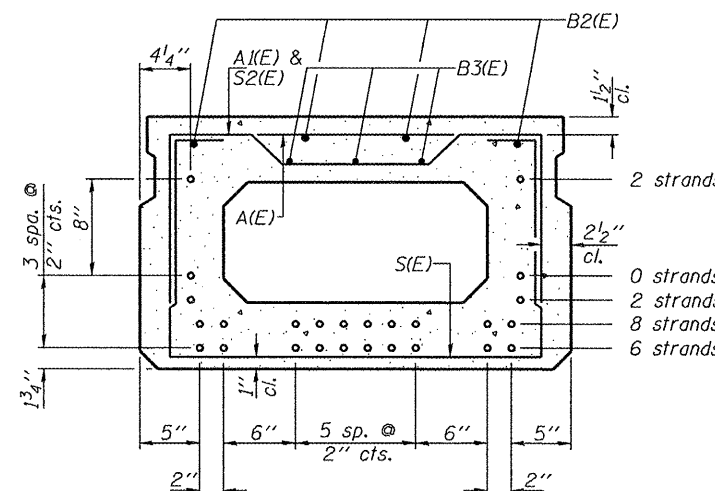

SECTION B-B
(Showing reinforcement and permissible strand locations)

Note: Place the number of strands specified in each row symmetrically about the centerline of beam in the permissible strand locations shown.

DESIGN STRESSES

PRECAST PRESTRESSED UNITS

$f'_c = 6,000$ psi
 $f'_{ci} = 5,000$ psi
 $f_{pu} = 270,000$ psi ($1/2$ " ϕ low-lax strands)
 $f_{pbt} = 201,960$ psi ($1/2$ " ϕ low-lax strands)

BAR LIST
ONE BEAM ONLY
(For information only)

Bar	No.	Size	Length	Shape
A(E)	14	#4	2'-7"	—
A1(E)	30	#4	2'-10"	—
B2(E)	4	#5	49'-8"	—
B3(E)	3	#4	49'-8"	—
S1(E)	70	#4	6'-5"	U
S2(E)	60	#4	5'-2"	U
U(E)	8	#5	4'-0"	U
U1(E)	4	#4	5'-0"	U

Note: See sheet 5 of 14 for additional details and Bill of Material.

MINIMUM BAR LAP

#4 bar = 2'-0"
 #5 bar = 2'-6"

PD-2136-0

7-1-10



ELKHART
 Elkhart Business Center 1
 100 Larkin Court, Suite 1
 Elkhart, IN 46524
 Tel: 818.345.2200
 Fax: 818.345.7223
 www.gatesassociates.com

MADISON
 Madison Gas Building
 720 Olive, Suite 1500
 St. Louis, MO 63101
 Tel: 314.588.8381
 Fax: 314.588.9808

USER NAME =	DESIGNED - JAD	REVISED -
	CHECKED - MAG	REVISED -
PLOT SCALE =	DRAWN - JAD	REVISED -
PLOT DATE =	CHECKED - MAG	REVISED -

STATE OF ILLINOIS
DEPARTMENT OF TRANSPORTATION

21" x 36" PPC DECK BEAM (SPAN 2)
STRUCTURE NO. 060-3346

SHEET NO. 4 OF 14 SHEETS

TWP Road	SECTION	COUNTY	TOTAL SHEETS	SHEET NO.
305A	06-11114-00-BR	MADISON	25	11
CONTRACT NO.				

ILLINOIS FED. AID PROJECT