

**UNDERDRAIN NOTES**

THE CONTRACTOR SHALL INSTALL THE PROPOSED 4" P.E. TUBING UNDERDRAINS TO THE DEPTH AND GRADES SHOWN ON THIS SHEET. THE UNDERDRAINS SHALL BE INSTALLED AFTER THE LIME SUBGRADE PROCESSING HAS BEEN COMPLETED.

THE 4" P.E. TUBING SHALL BE CAPPED AT THE ENDS WHICH DO NOT CONNECT INTO EXISTING STRUCTURES.

THE TRENCH SHALL BE BACKFILLED AND COMPACTED WITH POROUS BACKFILL NO. 1 MATERIAL. THE TRENCH LOCATED IN TURF AREAS SHALL BE BACKFILLED UP TO WITHIN 1 FT. OF THE EXISTING GROUND ELEVATION. THE REMAINING 1 FT. OF TRENCH WILL BE BACKFILLED AND COMPACTED WITH EARTH MATERIAL.

THE PROPOSED UNDERDRAINS AND BACKFILLED MATERIAL WILL BE PAID FOR UNDER THE FOLLOWING ITEMS:  
 AR705411 "POROUS BACKFILL NO. 1" \_\_\_\_\_ PER C.Y.  
 AR705524 "4" PERFORATED UNDERDRAIN W/SOCK" \_\_\_\_\_ PER L.F.

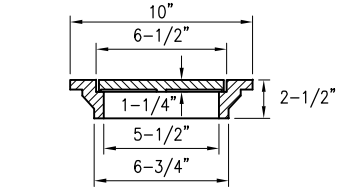
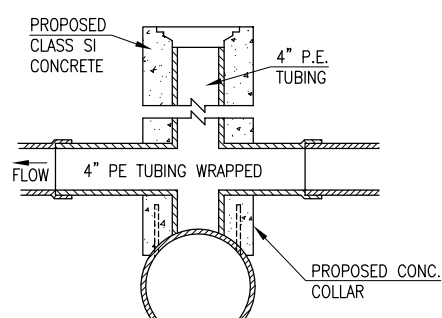
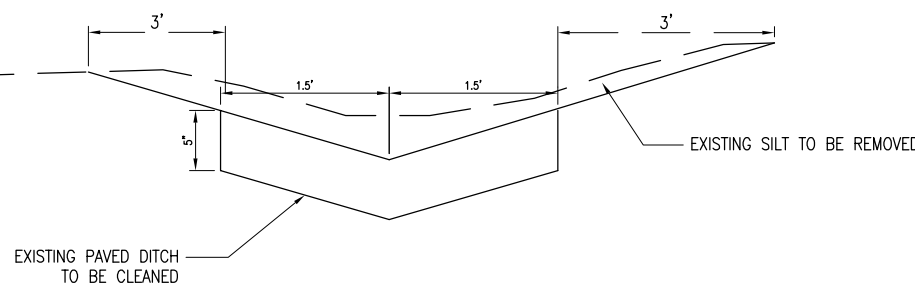

NEENAH R-6013, DEETER 1810, EAST JORDAN 2790-6 OR APPROVED EQUAL

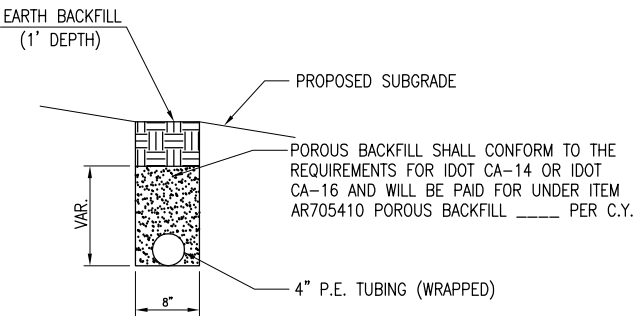

**LEGEND**

- EXISTING IMPROVEMENTS
- PROPOSED IMPROVEMENTS
- EXISTING STORM SEWER
- PROPOSED STORM SEWER
- EXISTING UNDERDRAIN
- PROPOSED UNDERDRAIN
- EXISTING PAVED DITCH
- EXISTING RIPRAP
- PROPOSED RIPRAP
- EXISTING UNDERDRAIN INSPECTION HOLE
- PROPOSED INSPECTION HOLE
- PROPOSED CONCRETE HEADWALL
- EXISTING CONCRETE FLARED END SECTION
- PROPOSED CONCRETE FLARED END SECTION

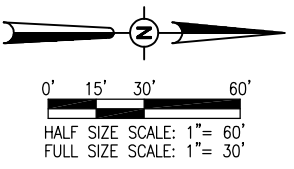

| REVISION | DATE | BY |
|----------|------|----|
|          |      |    |
|          |      |    |
|          |      |    |
|          |      |    |
|          |      |    |
|          |      |    |
|          |      |    |
|          |      |    |
|          |      |    |
|          |      |    |

**LITCHFIELD MUNICIPAL AIRPORT  
LITCHFIELD, ILLINOIS**

IL PROJ.: 31F-4046 A.I.P. PROJ.: 3-17-0063-B17

|                                  |          |     |          |
|----------------------------------|----------|-----|----------|
| Hanson Project No. 10A0094D_0800 | LAYOUT   | MDR | 02/15/11 |
| Filename: R-132DRN.DWG           | DRAWN    | MDR | 02/15/11 |
| Scale: 1"=30'                    | REVIEWED | CAH | 02/17/11 |
| Date: 02/04/11                   |          |     |          |

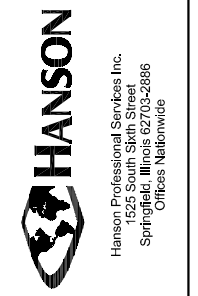

**TAXIWAY "C"  
EXTENSION**

PROPOSED DRAINAGE PLAN  
 STA. 72+00 TO STA. 80+00

MAR 14 2011 9:03 AM HAGL000382 I:\AIRPORTS\LITCHFIELD\10A0094\CADD\AIRPORT\PROJECT\132DRN.DWG - STA. 72+00 TO STA. 80+00