

STATE OF ILLINOIS
DEPARTMENT OF TRANSPORTATION

F.A.P. RTE.	SECTION	COUNTY	TOTAL SHEETS	SHEET NO.
317	(20,21)PP	IROQUOIS	9	1
		ILLINOIS	CONTRACT NO. 66M43	

INDEX OF SHEETS

1. COVER SHEET
2. GENERAL NOTES
3. SUMMARY OF QUANTITIES
4. TYPICAL SECTION
- 5-7. SCHEDULES
8. CLASS B PAVEMENT PATCHING DETAILS
9. TEMPORARY INFORMATION SIGNING

HIGHWAY STANDARDS

- | | |
|-----------|--|
| 000001-08 | STANDARD SYMBOLS, ABBREVIATIONS AND PATTERNS |
| 001001-02 | AREAS OF REINFORCEMENT BARS |
| 001006 | DECIMAL OF AN INCH AND OF A FOOT |
| 701001-02 | OFF-ROAD OPERATIONS 2L, 2W, MORE THAN 15' (4.5 m) AWAY |
| 701006-05 | OFF-ROAD OPERATIONS 2L, 2W, 15' (4.5 m) TO 24" (600 mm) FROM PAVEMENT EDGE |
| 701301-04 | LANE CLOSURE, 2L, 2W, SHORT TIME OPERATIONS |
| 701336-07 | LANE CLOSURE, 2L, 2W, WORK AREAS IN SERIES, FOR SPEEDS ≥ 45 MPH |
| 701501-06 | URBAN LANE CLOSURE, 2L, 2W, UNDIVIDED |
| 701901-08 | TRAFFIC CONTROL DEVICES |

PROPOSED HIGHWAY PLANS

FAP ROUTE 317 (US 24) SECTION (20,21)PP CLASS B PAVEMENT PATCHING IROQUOIS COUNTY C-93-068-22

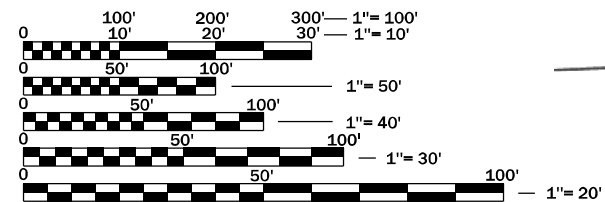
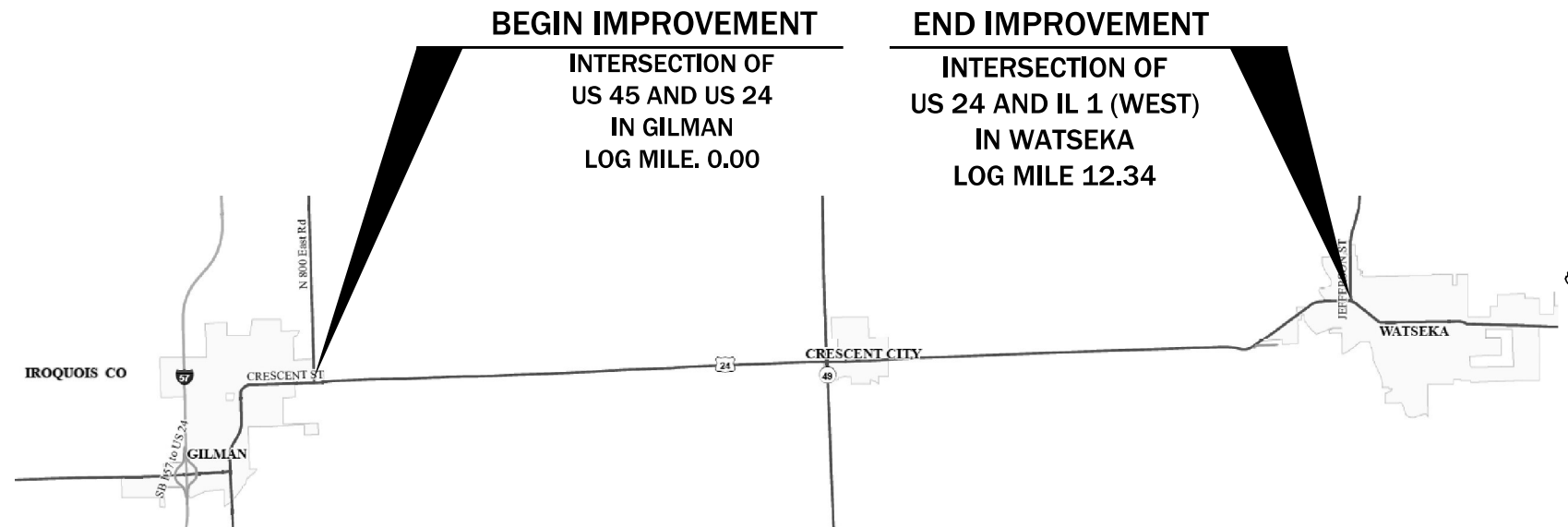
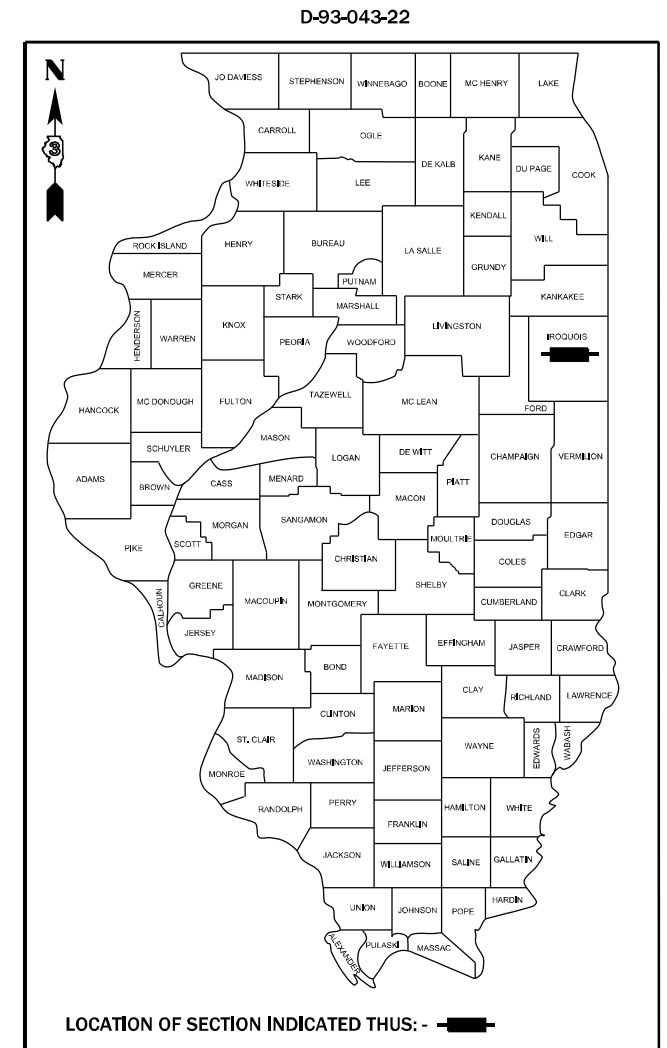

FULL SIZE PLANS HAVE BEEN PREPARED USING STANDARD ENGINEERING SCALES. REDUCED SIZED PLANS WILL NOT CONFORM TO STANDARD SCALES. IN MAKING MEASUREMENTS ON REDUCED PLANS, THE ABOVE SCALES MAY BE USED.

J.U.L.I.E.
JOINT UTILITY LOCATION INFORMATION FOR EXCAVATION
1-800-892-0123
OR 811

PROJECT ENGINEER YOGESH PATEL P.E.
UNIT CHIEF RON WOODSHANK
DISTRICT 3 NO. (815) 434-6131
CONTRACT NO. 66M43

GROSS LENGTH = 65,156 FT. = 12.34 MILES
NET LENGTH = 510 FT. = 0.10 MILES

FUNCTIONAL CLASSIFICATION
RURAL/URBAN OTHER PRINCIPAL ARTERIAL
F.A.P. ROUTE 317 US 24)
2019 ADT = 4650
P.V. 79.1 % S.U. 5.6 % M.U. 15.3 %

STATE OF ILLINOIS
DEPARTMENT OF TRANSPORTATION

SUBMITTED January 31, 2022
[Signature] REGIONAL ENGINEER

March 25, 2022
[Signature] ENGINEER OF DESIGN AND ENVIRONMENT

March 28, 2022
[Signature] DIRECTOR OF HIGHWAYS PROJECT IMPLEMENTATION

**PRINTED BY THE AUTHORITY
OF THE STATE OF ILLINOIS**

GENERAL NOTES

PLAN DIMENSIONS AND DETAILS RELATIVE TO EXISTING PLANS ARE SUBJECT TO NOMINAL CONSTRUCTION VARIATIONS. THE CONTRACTOR SHALL FIELD VERIFY EXISTING DIMENSIONS AND DETAILS AFFECTING NEW CONSTRUCTION AND MAKE NECESSARY APPROVED ADJUSTMENTS PRIOR TO CONSTRUCTION OR ORDERING OF MATERIALS. SUCH VARIATIONS SHALL NOT BE CAUSE FOR ADDITIONAL COMPENSATION FOR A CHANGE IN SCOPE OF WORK; HOWEVER, THE CONTRACTOR WILL BE PAID FOR THE QUANTITY ACTUALLY FURNISHED AT THE UNIT PRICE BID FOR THE WORK.

ALL EXCAVATED MATERIAL, WHICH INCLUDES DIGGING OR GRADING OF ANY SOIL OR FILL MATERIAL, WITH THE EXCEPTION OF AGGREGATE FILLS, MUST BE INCORPORATED WITHIN THE IDOT RIGHT OF WAY.

THE CONTRACTOR SHALL CONTACT JULIE AT LEAST 48 HOURS PRIOR TO EXCAVATION TO DETERMINE WHICH UTILITIES ARE IN THE AREA.

COMMITMENTS

STATE OF ILLINOIS
DEPARTMENT OF TRANSPORTATION
DISTRICT THREE
AS BUILT INFORMATION

SUPERVISING CONSTRUCTION FIELD ENGINEER

RESIDENT ENGINEER / TECHNICIAN

START & END DATES
OF CONSTRUCTION:

INSPECTORS:

STATE OF ILLINOIS
DEPARTMENT OF TRANSPORTATION
DISTRICT THREE

PREPARED BY: _____
DISTRICT STUDIES & PLANS ENGINEER

DATE: _____

EXAMINED BY: _____
DISTRICT CONSTRUCTION ENGINEER

DISTRICT MATERIALS ENGINEER

DISTRICT OPERATIONS ENGINEER

FILE NAME =	USER NAME = woodshank1	DESIGNED - EVAN MARINI	REVISED -	STATE OF ILLINOIS DEPARTMENT OF TRANSPORTATION	GENERAL NOTES	F.A.P. RTE.	SECTION	COUNTY	TOTAL SHEETS	SHEET NO.	
pw:\idot\pw\berkeley.com\PWIDOT\Documents\IDOT Office\District 3\Projects\0366M43\CADData\0366M43 - PLANS.dgn	DRAWN - EVAN MARINI	REVISED -	317			(20,21)PP	IROQUOIS	10	2		
Default	PLOT SCALE = 100,0000' / in.	CHECKED - RON WOODSHANK	REVISED -			CONTRACT NO. 66M43					
	PLOT DATE = 1/25/2022	DATE - 1/22/2019	REVISED -			SCALE:	SHEET 1	OF 1	SHEETS	STA.	TO STA.

CODE NO.	ITEM	UNIT	TOTAL QUANTITY	CONSTRUCTION CODE	
				CONTRACT MAINTENANCE 100% STATE ROADWAY 0006 RURAL	
44200050	WELDED WIRE REINFORCEMENT	SQ YD	85	85	
44200982	CLASS B PATCHES, TYPE II, 11 INCH	SQ YD	24	24	
44201019	CLASS B PATCHES, TYPE II, 14 INCH	SQ YD	559	559	
44201023	CLASS B PATCHES, TYPE III, 14 INCH	SQ YD	33	33	
44201025	CLASS B PATCHES, TYPE IV, 14 INCH	SQ YD	35	35	
44201043	CLASS B PATCHES, TYPE II, 16 INCH	SQ YD	617	617	
44201047	CLASS B PATCHES, TYPE III, 16 INCH	SQ YD	17	17	
44201299	DOWEL BARS 1 1/2"	EACH	2940	2940	
44213200	SAW CUTS	FOOT	7216	7216	
44213204	TIE BARS 3/4"	EACH	30	30	
67100100	MOBILIZATION	L SUM	1	1	
70100600	TRAFFIC CONTROL AND PROTECTION, STANDARD 701336	L SUM	1	1	
70102620	TRAFFIC CONTROL AND PROTECTION, STANDARD 701501	L SUM	1	1	
Z0030850	TEMPORARY INFORMATION SIGNING	SQ FT	42	42	

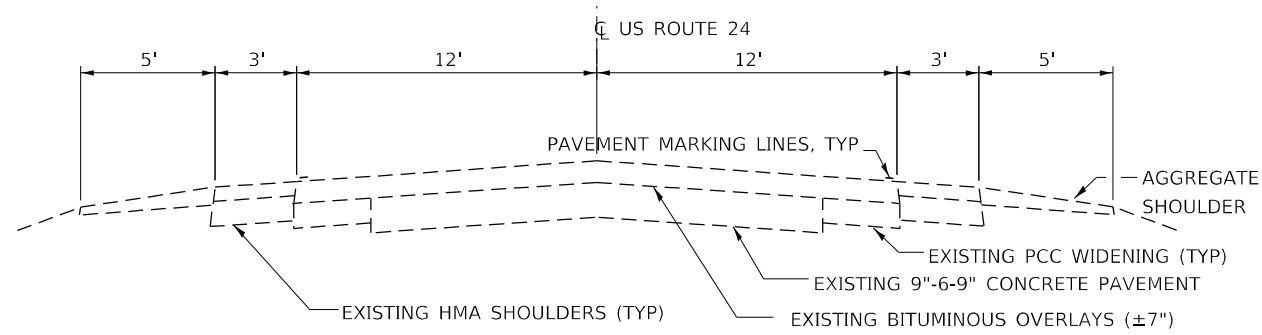

TYPICAL SECTION NO. 1

LOG MILE 0.00 TO LOG MILE 6.01

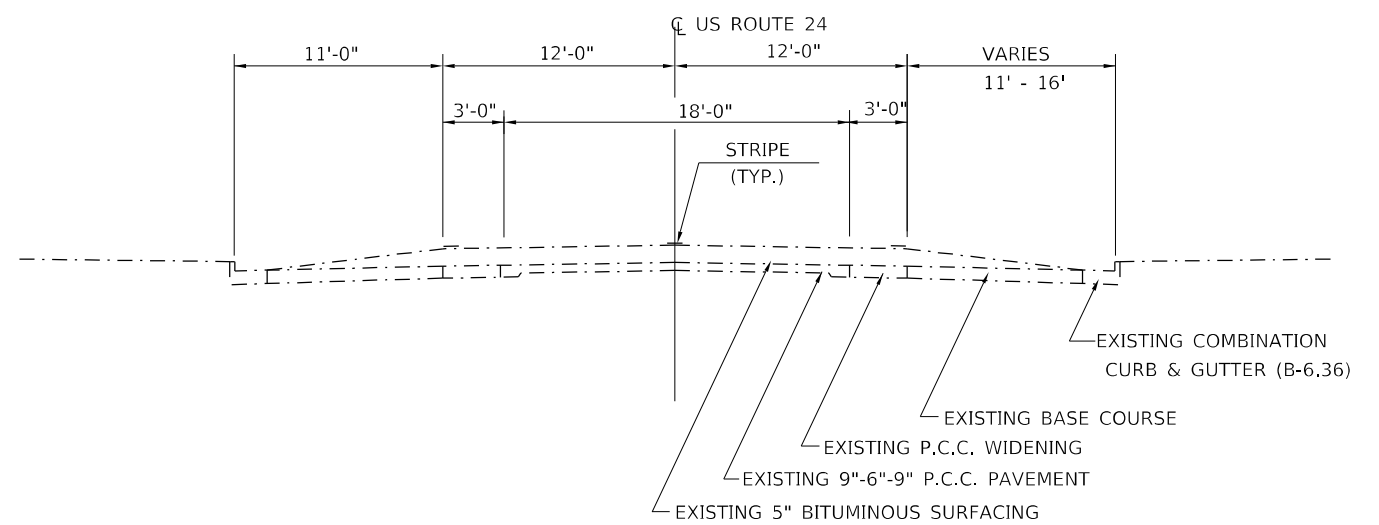

TYPICAL SECTION NO. 5

LOG MILE 6.10 TO LOG MILE 6.23

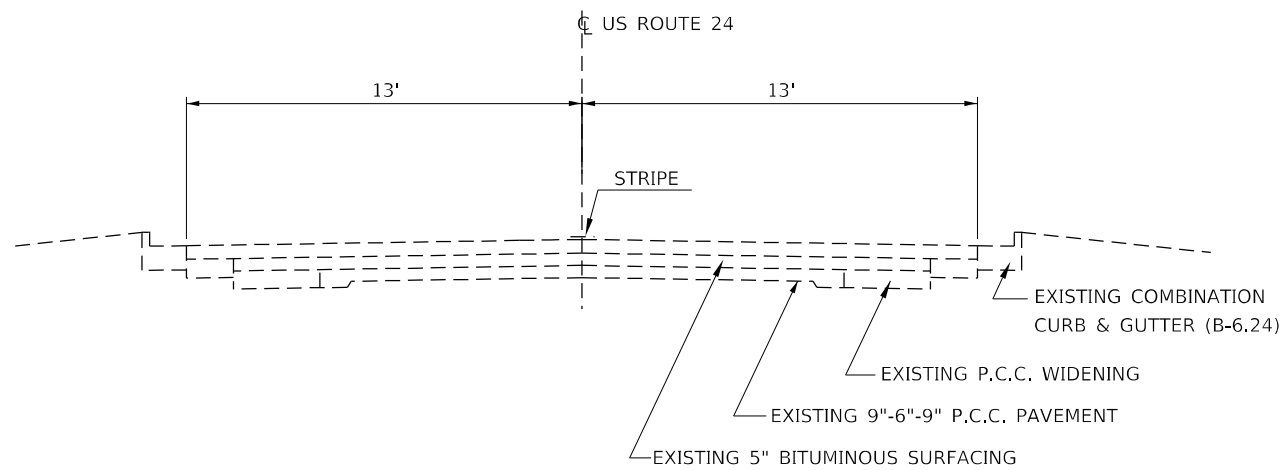

TYPICAL SECTION NO. 3

LOG MILE 6.01 TO LOG MILE 6.02

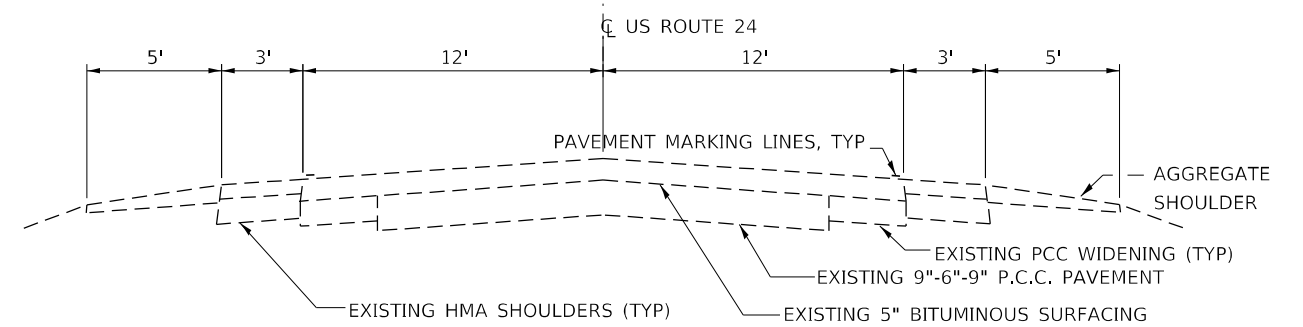

TYPICAL SECTION NO. 2

LOG MILE 6.23 TO LOG MILE 12.03

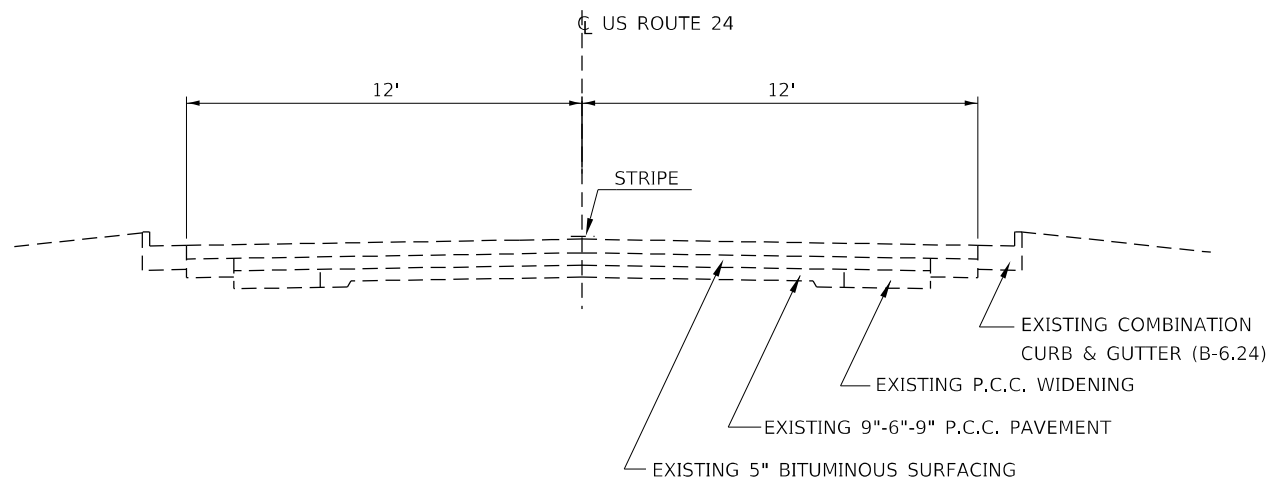

TYPICAL SECTION NO. 4

LOG MILE 6.02 TO LOG MILE 6.10

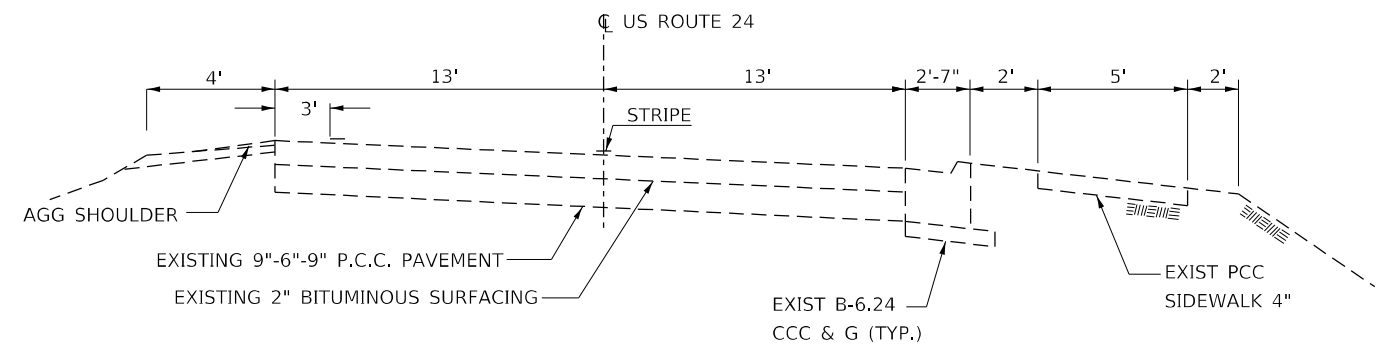

TYPICAL SECTION NO. 6

LOG MILE 12.03 TO LOG MILE 12.34

FILE NAME =	USER NAME = woodshank1	DESIGNED - EVAN MARINI	REVISED -
pw:\idol-pw\berkeley.com\PWIDOT\Documents\IDOT Office\District 3\Projects\ID366M43\CADData\ID366M43 - PLANS.dwg		DRAWN - EVAN MARINI	REVISED -
Default	PLOT SCALE = 100,0000' / in.	CHECKED - RON WOODSHANK	REVISED -
	PLOT DATE = 1/25/2022	DATE - 1/22/2019	REVISED -

**STATE OF ILLINOIS
DEPARTMENT OF TRANSPORTATION**

TYPICAL SECTIONS

SCALE: SHEET 1 OF 1 SHEETS STA. TO STA.

F.A.P. RTE.	SECTION	COUNTY	TOTAL SHEETS	SHEET NO.
317	(20,21)PP	IROQUOIS	10	4
CONTRACT NO. 66M43			ILLINOIS FED. AID PROJECT	

PATCHING SCHEDULE

EASTBOUND LANE						
LOCATION	PATCH LENGTH	CLASS B		DOWEL BARS 1 1/2"	SAW CUTS	WELDED WIRE REINF.
		TYPE II 16"	TYPE III 16"			
LOG MILE	(FT)	SQ YD	SQ YD	EACH	FOOT	SQ YD
0.30	6	8		20	48	
0.40	8	11		20	52	
0.45	13		17	20	62	17
0.60	6	8		20	48	
0.70	6	8		20	48	
0.80	6	8		20	48	
0.80	6	8		20	48	
0.90	6	8		20	48	
0.90	6	8		20	48	
1.05	6	8		20	48	
1.10	6	8		20	48	
1.15	6	8		20	48	
1.20	6	8		20	48	
1.30	6	8		20	48	
1.35	6	8		20	48	
1.60	8	11		20	52	
1.60	6	8		20	48	
1.70	8	11		20	52	
1.70	6	8		20	48	
1.90	6	8		20	48	
2.20	6	8		20	48	
2.40	6	8		20	48	
2.50	6	8		20	48	
2.70	8	11		20	52	
2.70	6	8		20	48	
2.80	8	11		20	52	
3.10	8	11		20	52	
3.50	6	8		20	48	
3.50	6	8		20	48	
3.70	6	8		20	48	
4.20	6	8		20	48	
4.30	6	8		20	48	
4.40	8	11		20	52	
4.90	6	8		20	48	
5.50	6	8		20	48	
5.70	6	8		20	48	
5.90	6	8		20	48	
6.40	6	8		20	48	
TOTAL	249	317	17	760	1866	17

PATCHING SCHEDULE

WESTBOUND LANE						
LOCATION	PATCH LENGTH	CLASS B		DOWEL BARS 1 1/2"	SAW CUTS	WELDED WIRE REINF.
		TYPE II 16"	TYPE III 16"			
LOG MILE	(FT)	SQ YD	SQ YD	EACH	FOOT	SQ YD
5.50	6	8		20	48	
5.30	6	8		20	48	
4.80	8	11		20	52	
4.70	6	8		20	48	
4.60	8	11		20	52	
4.50	6	8		20	48	
4.40	6	8		20	48	
4.30	6	8		20	48	
4.40	6	8		20	48	
4.10	6	8		20	48	
4.10	6	8		20	48	
4.10	6	8		20	48	
3.95	6	8		20	48	
3.90	6	8		20	48	
3.90	6	8		20	48	
3.90	6	8		20	48	
3.90	6	8		20	48	
3.80	8	11		20	52	
3.80	6	8		20	48	
3.70	6	8		20	48	
3.60	8	11		20	52	
3.60	6	8		20	48	
3.50	6	8		20	48	
3.40	6	8		20	48	
3.40	6	8		20	48	
3.20	6	8		20	48	
3.10	6	8		20	48	
3.00	6	8		20	48	
2.80	6	8		20	48	
2.60	6	8		20	48	
2.30	6	8		20	48	
2.20	6	8		20	48	
2.00	6	8		20	48	
2.00	6	8		20	48	
2.00	6	8		20	48	
TOTAL	224	300		720	1744	

PATCHING SCHEDULE

EASTBOUND LANE								
LOCATION	PATCH LENGTH	CLASS B			DOWEL BARS 1 1/2"	SAW CUTS FOOT	WELDED WIRE REINF. SQ YD	TIE BARS 3/4" SQ YD
		TYPE II 14"	TYPE III 14"	TYPE IV 14"				
LOG MILE	(FT)	SQ YD	SQ YD	SQ YD	EACH			
6.8	6	8			20	48		
6.9	6	8			20	48		
7.3	8	11			20	52		
7.5	8	11			20	52		
7.6	6	8			20	48		
7.7	6	8			20	48		
7.8	6	8			20	48		
7.9	26			35	20	88	35	13
8.15	6	8			20	48		
8.3	6	8			20	48		
8.3	6	8			20	48		
8.4	6	8			20	48		
8.4	6	8			20	48		
8.6	8	11			20	52		
8.6	6	8			20	48		
8.7	6	8			20	48		
8.7	6	8			20	48		
8.9	6	8			20	48		
9.0	6	8			20	48		
9.1	6	8			20	48		
9.1	6	8			20	48		
9.3	6	8			20	48		
9.4	6	8			20	48		
9.6	6	8			20	48		
9.9	6	8			20	48		
10.1	6	8			20	48		
10.15	6	8			20	48		
10.2	6	8			20	48		
10.3	6	8			20	48		
10.5	10	13			20	56		
10.6	8	11			20	52		
10.7	8	11			20	52		
10.8	6	8			20	48		
10.8	6	8			20	48		
11.0	6	8			20	48		
11.1	8	11			20	52		
11.2	6	8			20	48		
11.5	12	0	16		20	60		
11.80	6	8			20	48		
11.65	13		17		20	62	0	17
11.65	6	8			20	48		
11.60	6	8			20	48		
11.50	6	8			20	48		
11.50	6	8			20	48		
11.40	6	8			20	48		
TOTAL	319	359	33	35	900	2258	35	30

PATCHING SCHEDULE

WESTBOUND LANE								
LOCATION	PATCH LENGTH	CLASS B			DOWEL BARS 1 1/2"	SAW CUTS FOOT	WELDED WIRE REINF. SQ YD	TIE BARS 3/4" SQ YD
		TYPE II 14"	TYPE III 14"	TYPE IV 14"				
LOG MILE	(FT)	SQ YD	SQ YD	SQ YD	EACH			
11.30	6	8			20	48		
11.30	6	8			20	48		
11.20	6	8			20	48		
11.20	6	8			20	48		
11.10	6	8			20	48		
11.10	6	8			20	48		
11.00	6	8			20	48		
11.00	6	8			20	48		
10.90	6	8			20	48		
10.90	6	8			20	48		
10.80	6	8			20	48		
10.80	6	8			20	48		
10.70	6	8			20	48		
10.70	6	8			20	48		
10.60	6	8			20	48		
10.30	6	8			20	48		
9.00	6	8			20	48		
8.40	6	8			20	48		
7.80	6	8			20	48		
7.20	6	8			20	48		
6.60	6	8			20	48		
6.40	6	8			20	48		
6.30	6	8			20	48		
6.10	6	8			20	48		
5.70	6	8			20	48		
TOTAL	150	200			500	1200		

PATCHING SCHEDULE

EASTBOUND LANE				
LOCATION	PATCH LENGTH	CLASS B TYPE	DOWEL BARS	SAW CUTS
		II 11"	1 1/2"	
LOG MILE	(FT)	SQ YD	EACH	FOOT
12.1	6	8	20	48
12.1	6	8	20	48
TOTAL	12	16	40	96

PATCHING SCHEDULE

WESTBOUND LANE				
LOCATION	PATCH LENGTH	CLASS B TYPE	DOWEL BARS	SAW CUTS
		II 11"	1 1/2"	
LOG MILE	(FT)	SQ YD	EACH	FOOT
12.10	8	11	20	52
TOTAL	8	11	20	52

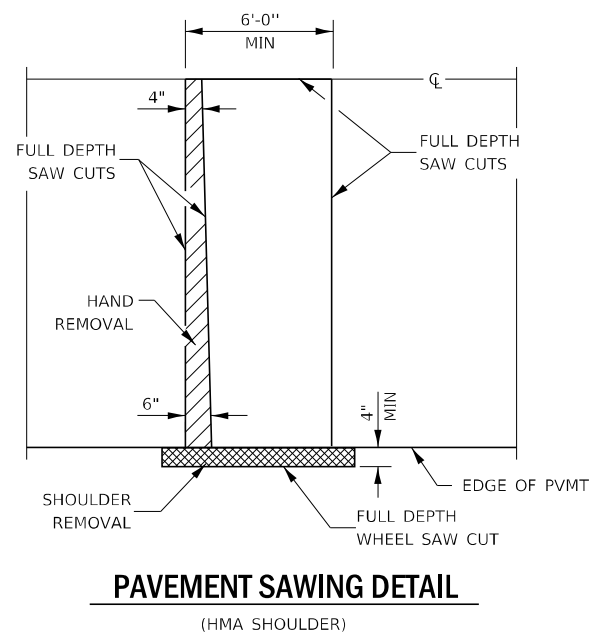

PAVEMENT SAWING DETAIL
(HMA SHOULDER)

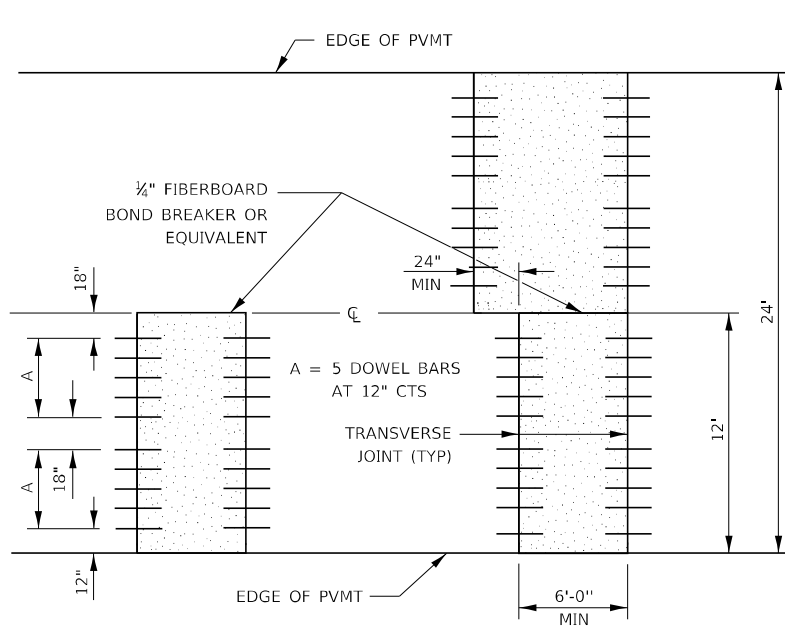

12' WIDE LANES

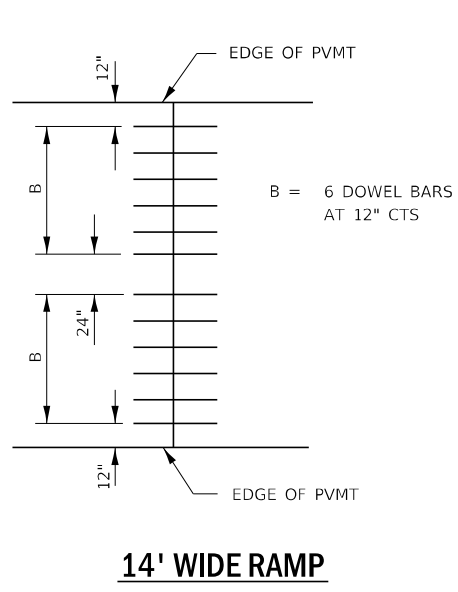

14' WIDE RAMP

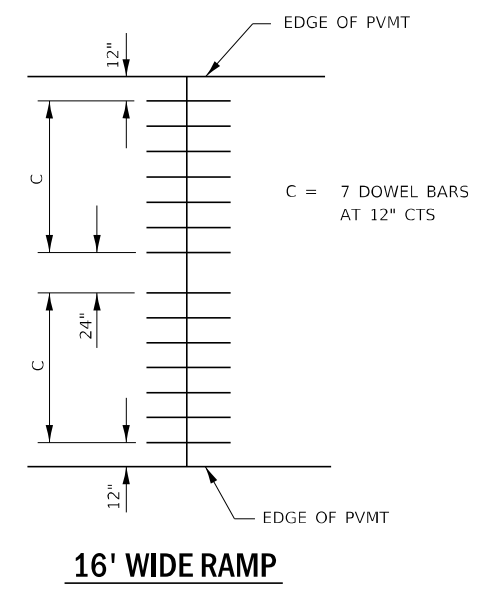

16' WIDE RAMP

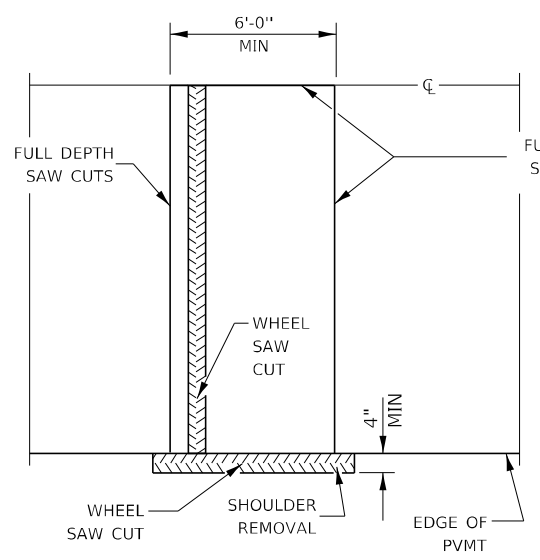

ALTERNATE SAWING DETAIL
(HMA SHOULDER)

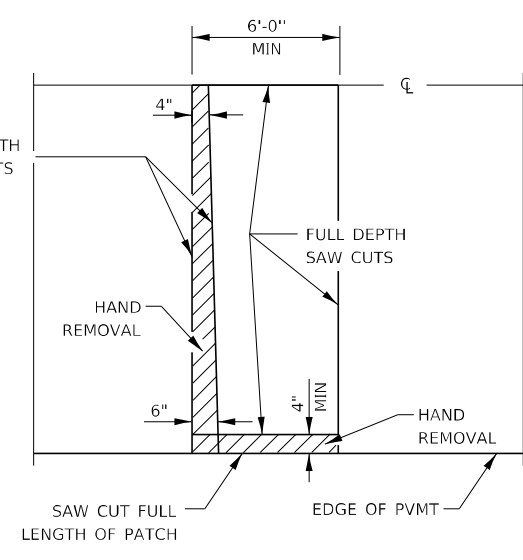

PAVEMENT SAWING DETAIL
(PCC SHOULDER)

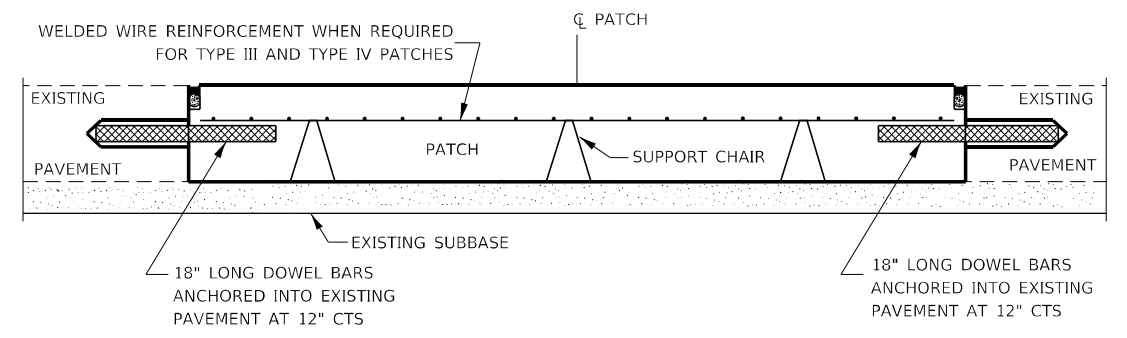

PATCHING WITHOUT HMA OVERLAY

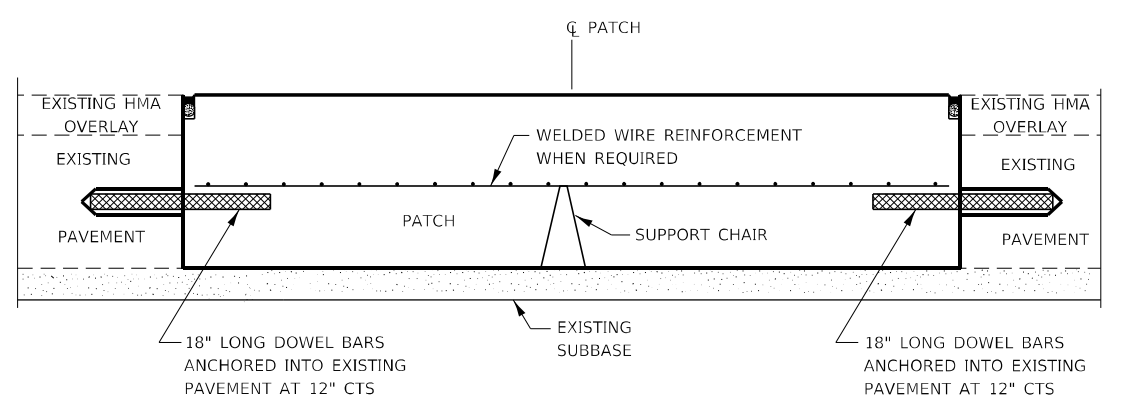

PATCHING WITH HMA OVERLAY

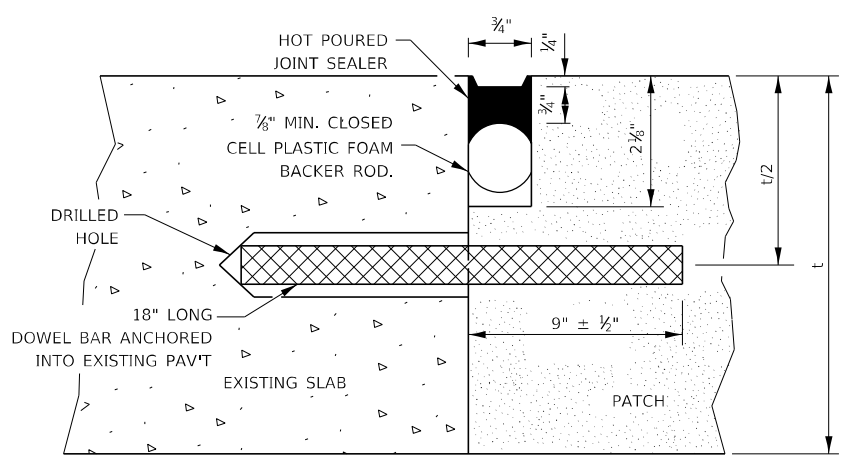

TRANSVERSE JOINT

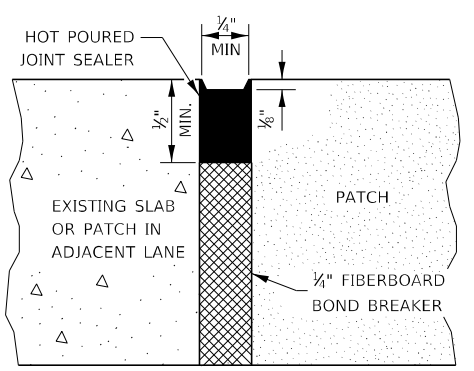

CENTERLINE JOINT

DOWEL BAR TABLE		
PAVEMENT THICKNESS	DOWEL BAR DIAMETER	HOLE DIAMETER
8" OR GREATER	1 1/2"	1 3/8"
7" THRU 7.99"	1 1/4"	1 3/8"
LESS THAN 7"	1"	1 3/8"

GENERAL NOTES

THE TRANSVERSE JOINTS FOR CLASS B PATCHES SHALL ALIGN WITH JOINTS OR CRACKS IN THE ADJACENT LANE WHENEVER POSSIBLE.
SEE STANDARD 420701 FOR DETAILS OF PAVEMENT WELDED WIRE REINFORCEMENT.

MODEL: Default
FILE: 66M43_PlanSheet-PAV.bentley.com/PWDOT/Document/1/DOT Office/Drawings/3/Project/ID366M43/000Data/ID366M43 - PLANS.dgn

USER NAME = woodshank	DESIGNED - EVAN MARINI	REVISED -
PLOT SCALE = 100,0000' / in.	DRAWN - EVAN MARINI	REVISED -
PLOT DATE = 1/25/2022	CHECKED - RON WOODSHANK	REVISED -
	DATE - 1/22/2019	REVISED -

**STATE OF ILLINOIS
DEPARTMENT OF TRANSPORTATION**

CLASS B PATCHING DETAILS

SCALE: SHEET 1 OF 2 SHEETS STA. TO STA.

F.A.P. RTE. 317	SECTION (20,21)PP	COUNTY IROQUOIS	TOTAL SHEETS 10	SHEET NO. 8
CONTRACT NO. 66M43				

ILLINOIS FED. AID PROJECT

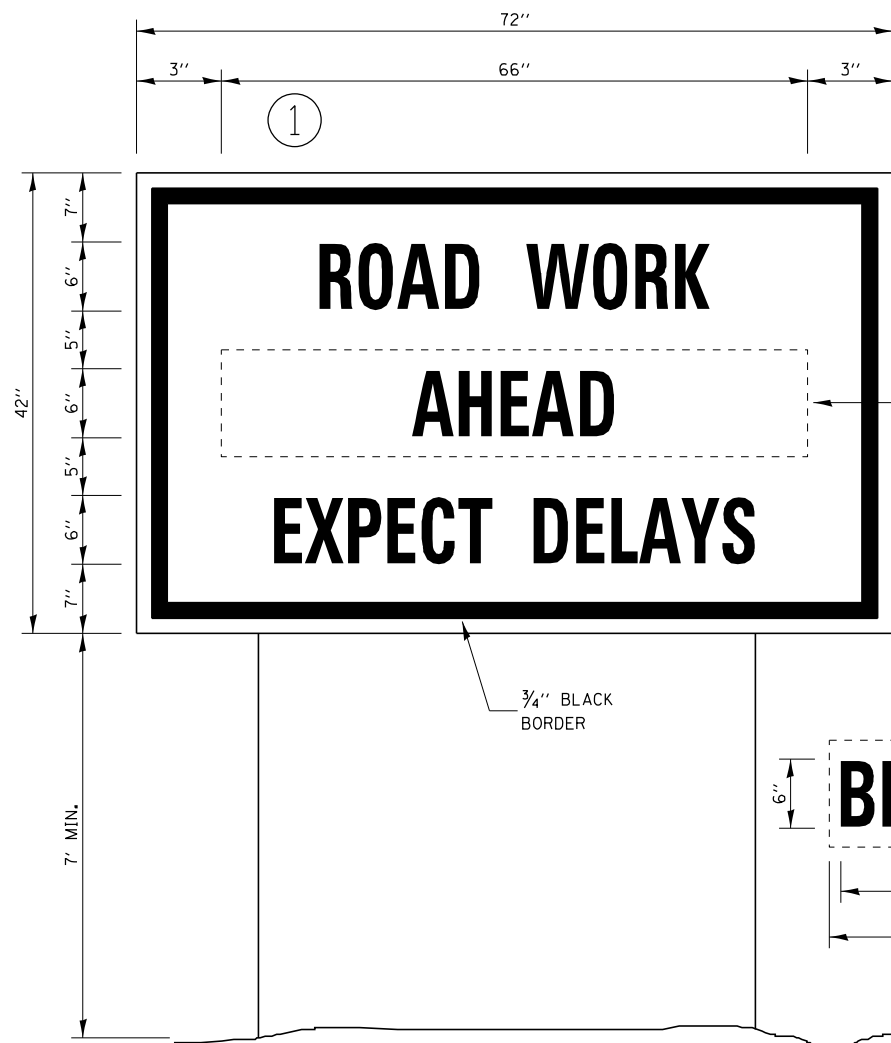

TEMPORARY INFORMATION SIGNING

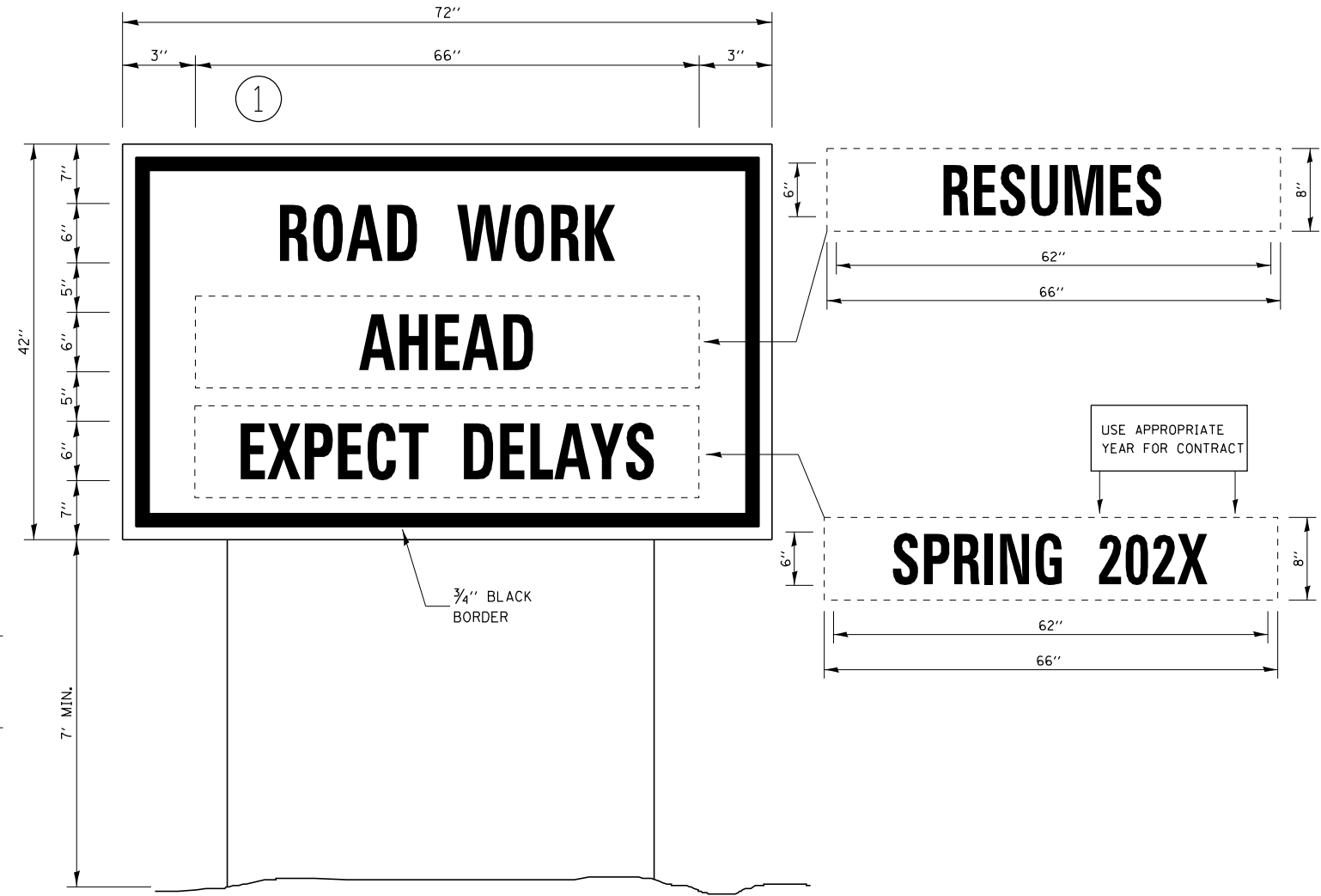

WINTER SHUT DOWN SIGNING

NOTES:

1. USE 6" D BLACK LETTERING ON FLOURESENT ORANGE BACKGROUND.
2. ERECT SIGNS AT LOCATIONS IN ADVANCE OF THE "ROAD CONSTRUCTION AHEAD" SIGNS AS DIRECTED BY THE ENGINEER.
3. ERECT SIGN ① WITH INSTALLED PANEL ② A MINIMUM OF ONE WEEK PRIOR TO THE START OF THE LANE CLOSURE.
4. REMOVE PANEL ② ON THAT DATE.
5. SEE SPECIAL PROVISION "TEMPORARY INFORMATION SIGNING" FOR ADDITIONAL INFORMATION.
6. WILL BE PAID FOR PER SQ FT AS "TEMPORARY INFORMATION SIGNING". EACH SIGN = 21 SQ FT AND THE DATE PANEL ② WILL NOT BE MEASURED SEPARATELY FOR PAYMENT.

FILE NAME =	USER NAME = woodshank1	DESIGNED - EVAN MARINI	REVISED -	STATE OF ILLINOIS DEPARTMENT OF TRANSPORTATION	TEMPORARY INFORMATION SIGNING			F.A.P. RTE.	SECTION	COUNTY	TOTAL SHEETS	SHEET NO.
pw:\illdot\pw\berntley.com\PWIDOT\Documents\IDOT Office\District 3\Projects\3186M43\CADData\3186M43 - PLANS.dwg	DRAWN - EVAN MARINI	REVISIED -	317					(20,21)PP	IROQUOIS	10	10	
Default	PLOT SCALE = 100,0000' / in.	CHECKED - RON WOODSHANK	REVISED -		CONTRACT NO. 66M43							
	PLOT DATE = 1/25/2022	DATE - 1/22/2019	REVISED -		SCALE:	SHEET 1	OF 1	SHEETS	STA.	TO STA.	ILLINOIS	FED. AID PROJECT