

STATE OF ILLINOIS
DEPARTMENT OF TRANSPORTATION

ROUTE NO.	SECTION	COUNTY	TOTAL SHEETS	SHEET NO.	SHEET NO. 28
FAP 301	177-2	STEPHENSON	386	168	47 SHEETS
FED. ROAD DIST. NO. 7	ILLINOIS	FED. AID PROJECT-			

Contract No. 64799

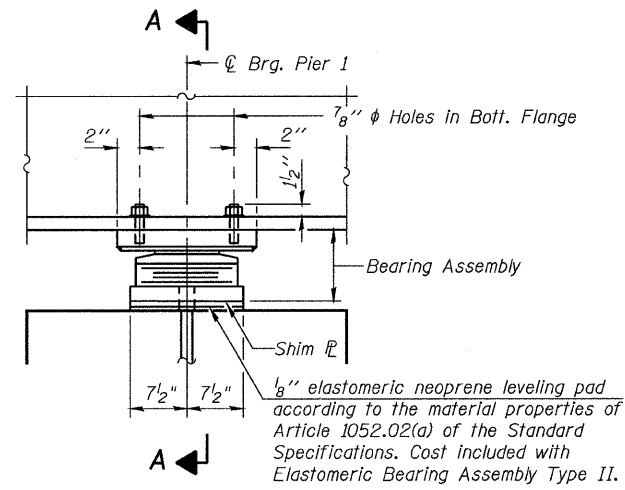

ELEVATION AT PIER 1

TYPE II ELASTOMERIC EXP. BRG. AT PIER 1

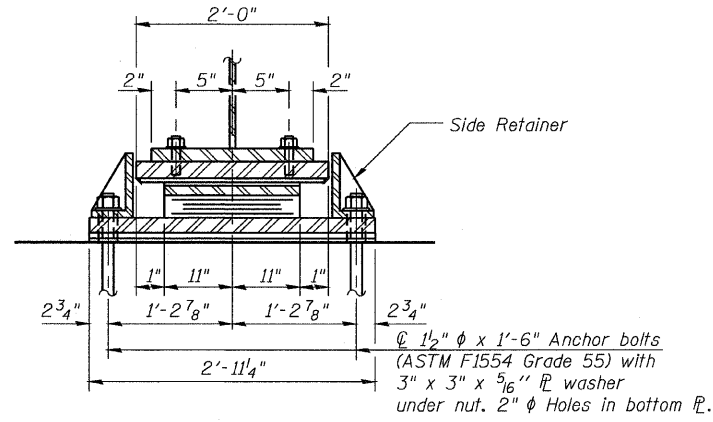

SECTION A-A

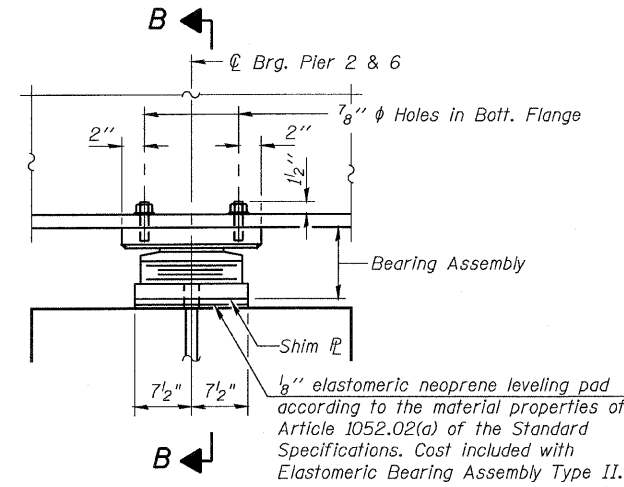

ELEVATION AT PIERS 2 & 6

TYPE II ELASTOMERIC EXP. BRG. AT PIERS 2 & 6

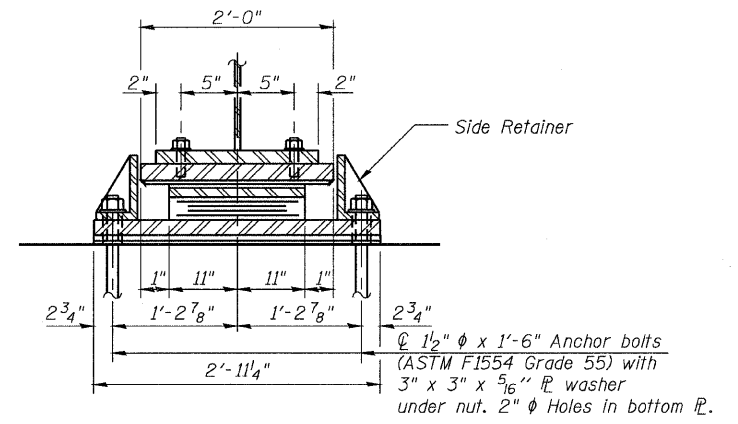

SECTION B-B

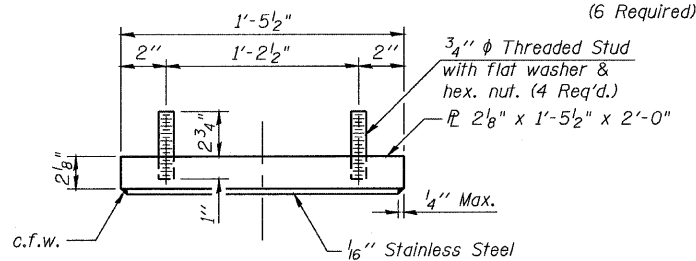

TOP BEARING ASSEMBLY

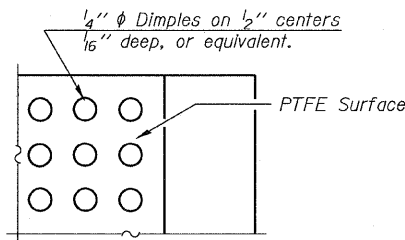

PLAN-PTFE SURFACE

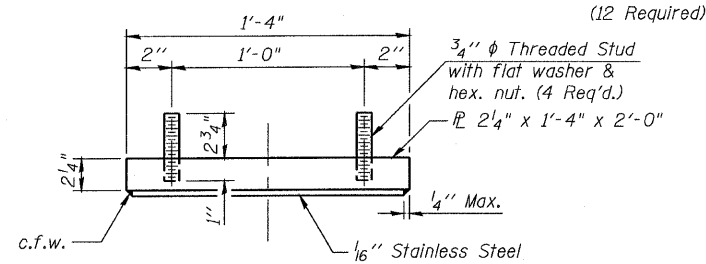

TOP BEARING ASSEMBLY

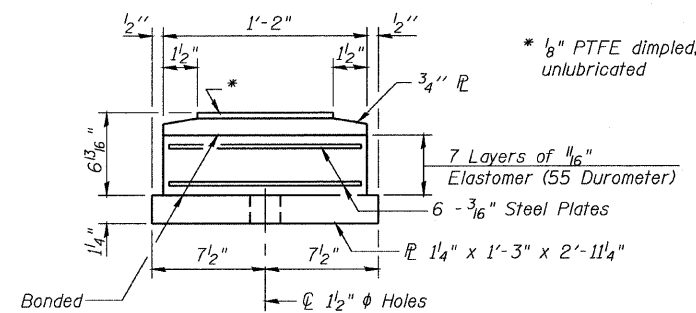

BOTTOM BEARING ASSEMBLY

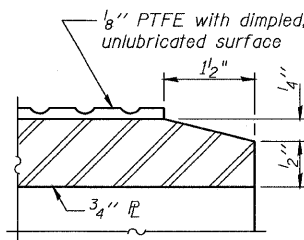

SECTION THRU PTFE

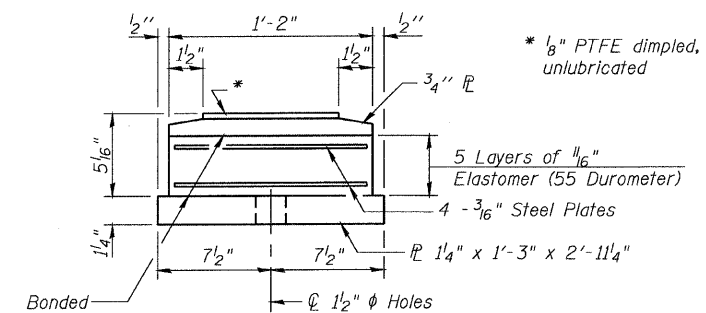

BOTTOM BEARING ASSEMBLY

Notes:

- Anchor bolts shall be ASTM F1554 all-thread (or an Engineer-approved alternate material) of the grade(s) and diameter(s) specified. ASTM A307 Grade C anchor bolts may be used in lieu of ASTM F1554 Grade 36 (Fy=36ksi). The corresponding specified grade of AASHTO M314 anchor bolts may be used in lieu of ASTM F1554.
- Anchor bolts for Type II bearings shall be placed in holes drilled through the bottom bearing plate after members are in place. Side retainers shall be placed after bolts are installed.
- Drilled and set anchor bolts shall be installed according to Article 521.06 of the Standard Specifications.
- Side retainers and other steel members required for the bearing assembly shall be included in the cost of Elastomeric Bearing Assembly, Type II.
- The 1/8" PTFE sheet shall be bonded directly to the top steel plate with a two-component, medium viscosity epoxy resin, conforming to the requirements of the Federal Specification MMM-A-134, Type I. The bond agent shall be applied on the full area of the contact surfaces.
- Bonding of 1/8" PTFE sheet during vulcanizing process will be permitted provided the process and method of adjusting assembly height is approved by the Engineer.
- Two 1/8 in. adjusting shims shall be provided for each bearing in addition to all other plates or shims and placed as shown on bearing details.

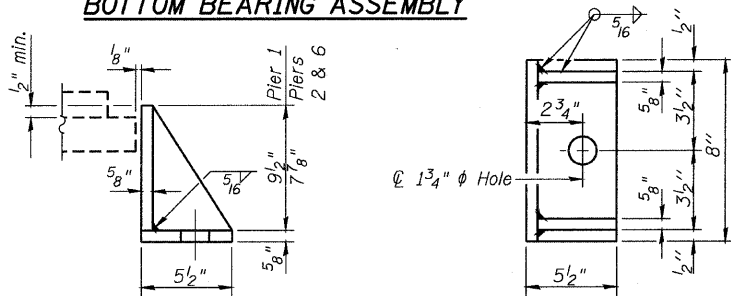

SIDE RETAINER

Equivalent rolled angle with stiffeners will be allowed in lieu of welded plates.

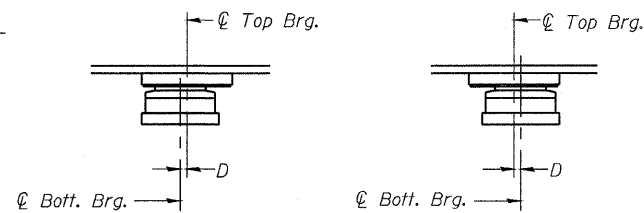

SETTING ANCHOR BOLTS AT EXP. BRG.

D=1/8" per each 100' of expansion for every 15° temp. change from the normal temp. of 50°F.

BILL OF MATERIAL

Item	Unit	Total
Elastomeric Bearing Assembly Type II	Each	18
Anchor Bolts 1/2" φ	Each	36

DESIGNED	S.CHELBIAN
CHECKED	J.BRISBOIS
DRAWN	D.C.PATEL
CHECKED	J.GRAINAWI

ELASTOMERIC BEARING
ASSEMBLY TYPE II
F.A.P. ROUTE 301 SECTION 177-2B-1
STEPHENSON COUNTY
STATION 540+65.71
STRUCTURE NO. 089-0082

