

F.A. RTE.	SECTION	COUNTY	TOTAL SHEETS	SHEET NO.
301	177-2 (-1A, B-1, VB-1)	STEPHENSON	386	222
STA.		TO STA.		
FED. ROAD DIST. NO.		ILLINOIS	FED. AID PROJECT	
P-92-029-02				

BITUMINOUS SHOULDER

GENERAL NOTES

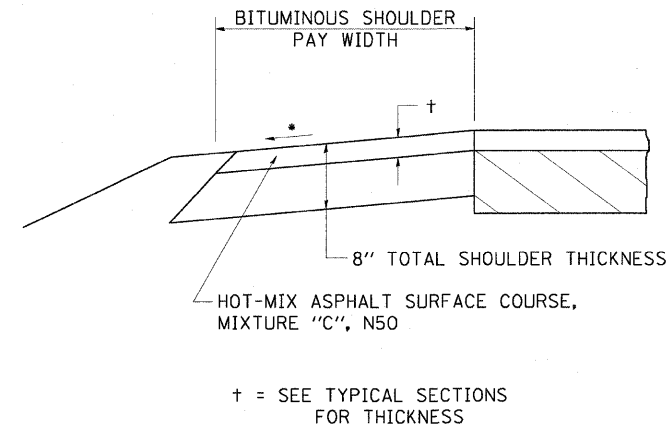

THE BITUMINOUS SHOULDER SHALL BE CONSTRUCTED IN ACCORDANCE WITH SECTION 482 EXCEPT THE TOP LIFT SHALL BE HOT-MIX ASPHALT SURFACE COURSE, MIXTURE "C", N50. THE WORK WILL BE PAID FOR AT THE CONTRACT UNIT PRICE PER TON FOR HOT-MIX ASPHALT SURFACE COURSE, MIXTURE "C", N50, AND SQUARE YARD FOR HOT-MIX ASPHALT SHOULDERS SUPERPAVE OF THE THICKNESS SPECIFIED.

USE HOT-MIX ASPHALT SURFACE COURSE, MIXTURE "C", N50 WHEN RESURFACING EXISTING BITUMINOUS SHOULDERS. THE THICKNESS IS SHOWN ON THE TYPICAL SECTIONS. THIS WORK WILL BE PAID FOR AT THE CONTRACT UNIT PRICE PER TON FOR HOT-MIX ASPHALT SURFACE COURSE, MIXTURE "C", N50.

REMOVAL OF MATERIAL FOR PLACEMENT OF THE BITUMINOUS SHOULDER TO BE PAID FOR IN UNITS FOR EXCAVATING AND GRADING EXISTING SHOULDERS OR IN CUBIC YARDS FOR EARTH EXCAVATION OR EARTH EXCAVATION WIDENING.

ALL DIMENSIONS ARE IN MILLIMETERS (INCHES) UNLESS OTHERWISE NOTED.

* 4% WHEN MAINLINE IS ON TANGENT. FOR CROSS SLOPE ON SUPERELEVATION SECTION, SEE HIGHWAY STANDARD 482001 OR 482006.

BITUMINOUS SHOULDER 23.4a

REVISED 5-30-03

DELINEATOR AND POST ORIENTATION

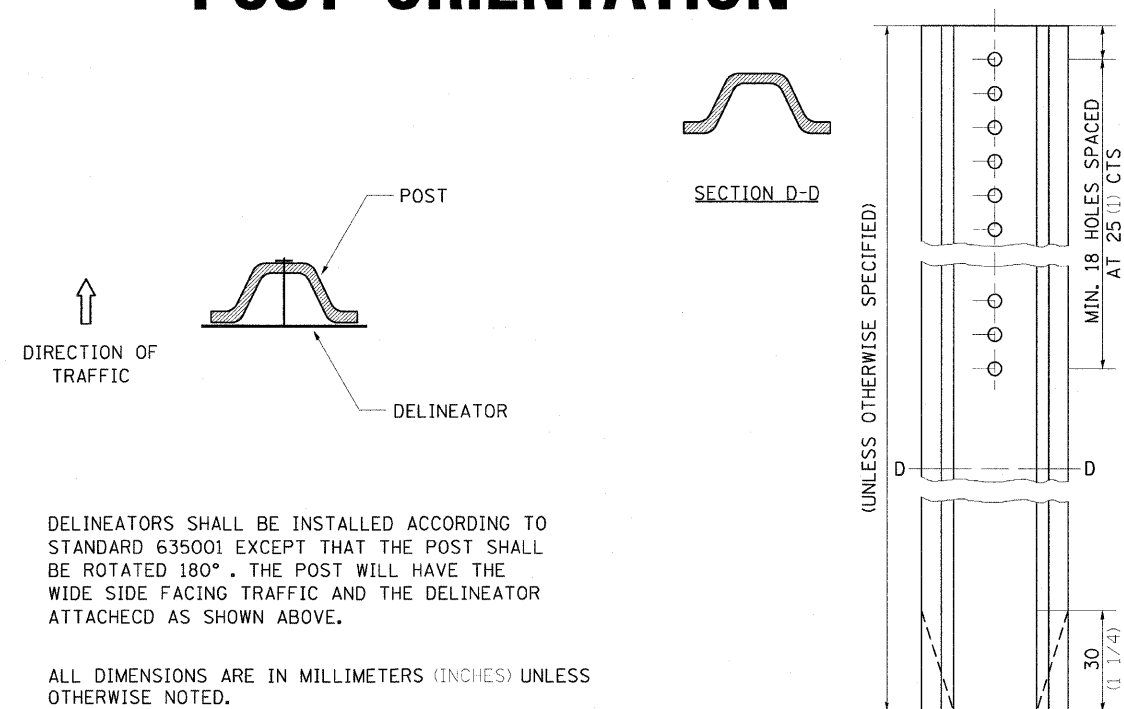

DELINEATORS SHALL BE INSTALLED ACCORDING TO STANDARD 635001 EXCEPT THAT THE POST SHALL BE ROTATED 180°. THE POST WILL HAVE THE WIDE SIDE FACING TRAFFIC AND THE DELINEATOR ATTACHED AS SHOWN ABOVE.

ALL DIMENSIONS ARE IN MILLIMETERS (INCHES) UNLESS OTHERWISE NOTED.

DELINEATOR AND POST ORIENTATION 37.4

REVISED 1-31-00