

(W10-1)

\* MINIMUM DISTANCE  
400' FOR 55 MPH  
250' FOR 45 MPH  
100' FOR 35 MPH OR LESS

### PAVEMENT MARKINGS AT RAILROAD-HIGHWAY GRADE CROSSING

NOTES:  
THE TRANSVERSE SPREAD OF THE "X" MAY VARY ACCORDING TO LANE WIDTH.

ON MULTI-LANE ROADS, THE STOP LINES SHALL EXTEND ACROSS ALL APPROACH LANES AND SEPARATE RXR SYMBOLS SHALL BE PLACED ADJACENT TO EACH OTHER IN EACH LANE.

WHEN THE PAVEMENT MARKING SYMBOL IS USED, A PORTION OF THE SYMBOL SHOULD BE LOCATED DIRECTLY ADJACENT TO THE ADVANCE WARNING SIGN (W10-1).

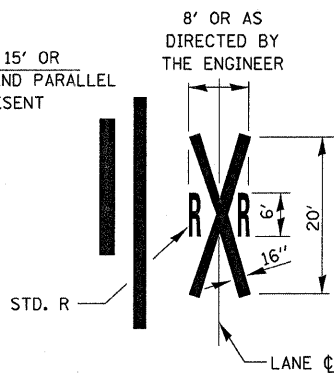

STD. R

LANE C

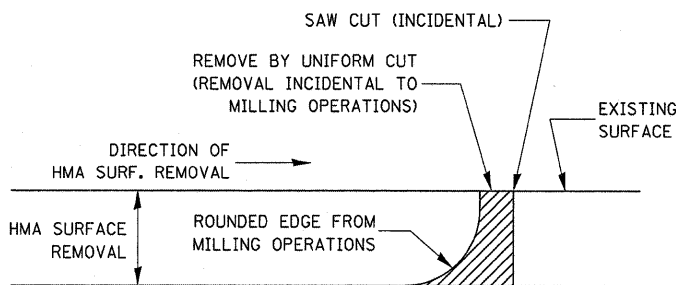

NOTE:  
WHEN MILLING OPERATIONS PRODUCE A ROUNDED EDGE, THEN A SAW CUT SHALL BE USED TO MANUFACTURE A PERPENDICULAR EDGE AS SHOWN IN THE DETAIL. THE ENGINEER SHALL BE THE SOLE JUDGE CONCERNING THE USE OF THIS DETAIL.

### HMA DETAIL AT BUTT JOINTS

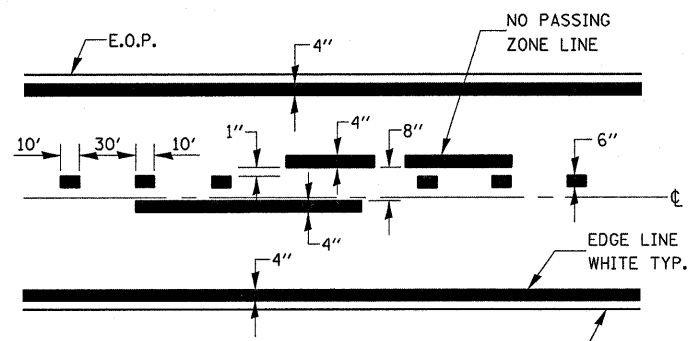

CENTERLINE & NO PASSING ZONE LINES - YELLOW

(SEE TYPICAL SECTIONS)

### PAVEMENT MARKING

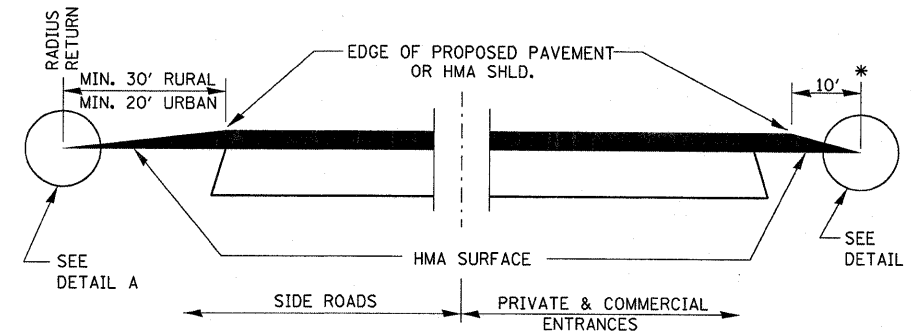

### SECTION A-A DETAILS AT ENTRANCES & SIDE ROADS

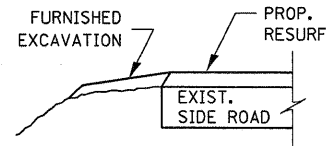

### SECTION B-B

THE COST OF REMOVAL AT EXISTING HMA OR P.C.C. LOCATIONS SHALL BE PAID FOR PER SQ. YD. BY THE APPROPRIATE PAY ITEM. REMOVAL AT THE EXISTING AGG. LOCATIONS SHALL BE INCIDENTAL TO THE HMA. A-3 LOCATIONS SHALL BE FEATHER TAPERED.

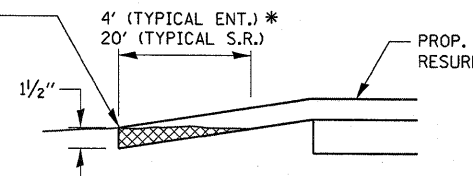

### DETAIL A

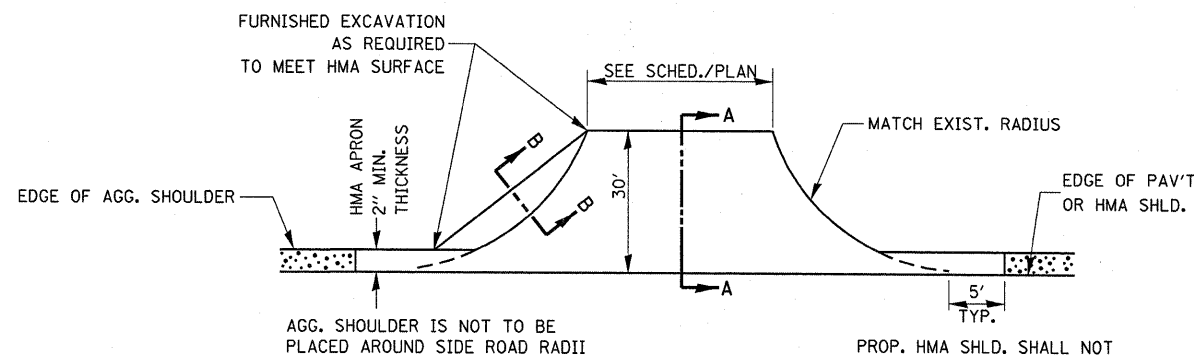

### PLAN AT SIDE ROADS

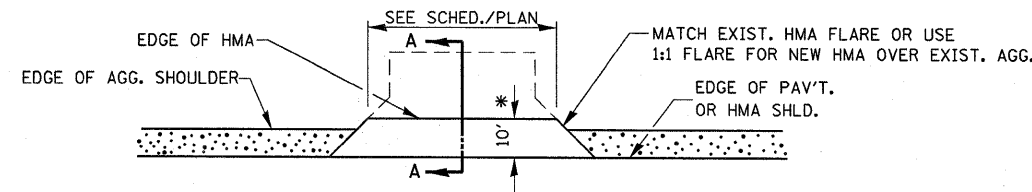

### PLAN AT PRIVATE & COMMERCIAL ENTRANCES

(DO NOT RESURFACE FIELD ENTRANCES)

\* PROPOSED HMA RESURFACING AT PUBLIC EDUCATIONAL FACILITY ENTRANCES SHALL BE EXTENDED TO THE RIGHT-OF-WAY LIMITS.

FILE NAME =	USER NAME = carpenterdj	DESIGNED -	REVISED -
ca:\pwork\pwidot\CARPENTERDJ\d0175591	3366643-sht-details.DGN	DRAWN -	REVISED -
	PLOT SCALE = 50,0000 ' / IN.	CHECKED -	REVISED -
	PLOT DATE = Jan 25, 2010 - 07:13:23 AM	DATE -	REVISED -

STATE OF ILLINOIS  
DEPARTMENT OF TRANSPORTATION

DETAILS			
SCALE: _____	SHEET NO. _____	OF _____ SHEETS	STA. _____ TO STA. _____

F.A.P. RTE.	SECTION	COUNTY	TOTAL SHEETS	SHEET NO.
332	(3, D-URS-2, (14, 15, 2)RS	IROQUOIS	15	14
CONTRACT NO. 66643				
ILLINOIS FED. AID PROJECT				