

MILLING TRANSITION DETAIL

- STATION 479+30.00 TO STATION 479+65.00
- STATION 494+40.00 TO STATION 494+75.00
- STATION 503+83.00 TO STATION 504+18.00
- STATION 653+45.00 TO STATION 653+80.00
- STATION 661+44.00 TO STATION 661+79.00
- STATION 666+84.00 TO STATION 667+19.00
- STATION 679+09.00 TO STATION 679+44.00
- STATION 714+11.00 TO STATION 714+46.00
- STATION 717+50.00 TO STATION 717+85.00
- STATION 722+31.00 TO STATION 722+66.00
- STATION 736+38.50 TO STATION 736+68.50
- STATION 740+05.00 TO STATION 740+40.00
- STATION 750+85.00 TO STATION 751+20.00

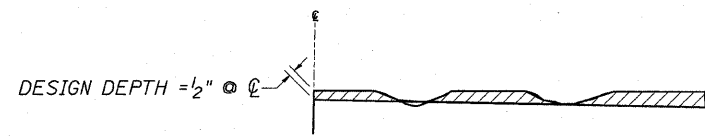

NOTES:

1. MILLING SHALL BE DONE TO ATTAIN A 3/16 "/FT. SLOPE IN CROWN SECTIONS
2. EXISTING S.E. AND S.E. TRANSITIONS SHALL BE MAINTAINED UNLESS OTHERWISE SHOWN ON THE PLANS.
3. MILLING TO THE BOTTOM OF WHEEL RUTS SHALL NOT BE NECESSARY UNLESS REQUIRED TO OBTAIN SLOPE OR THE DESIGN DEPTH AT CENTERLINE.
4. THE AVERAGE DEPTH OF MILLING IS ESTIMATED TO BE 1/2" BUT MAY VARY IN ISOLATED LOCATIONS.

HOT-MIX ASPHALT SURFACE REMOVAL (VARIABLE DEPTH) DETAIL

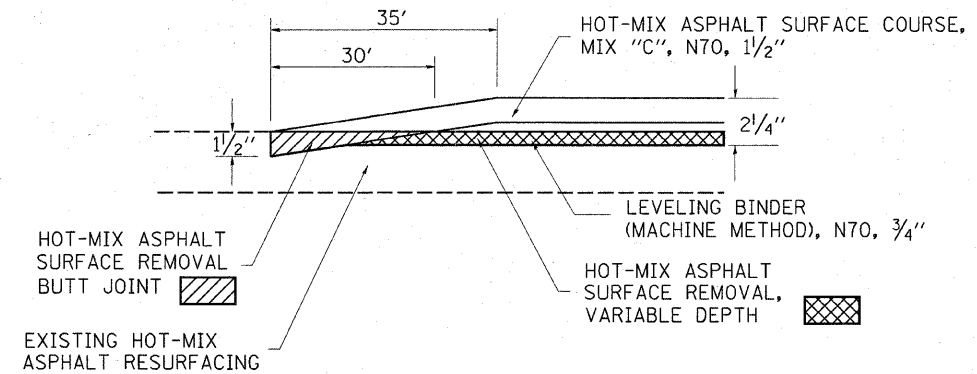

BUTT JOINT DETAIL

- STATION 706+28.00 TO STATION 706+63.00
- STATION 709+64.00 TO STATION 709+99.00
- STATION 761+65.00 TO STATION 762+00.00

PARTIAL DEPTH PATCHING DETAIL

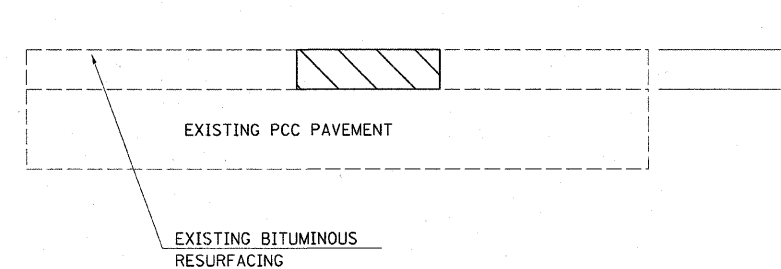
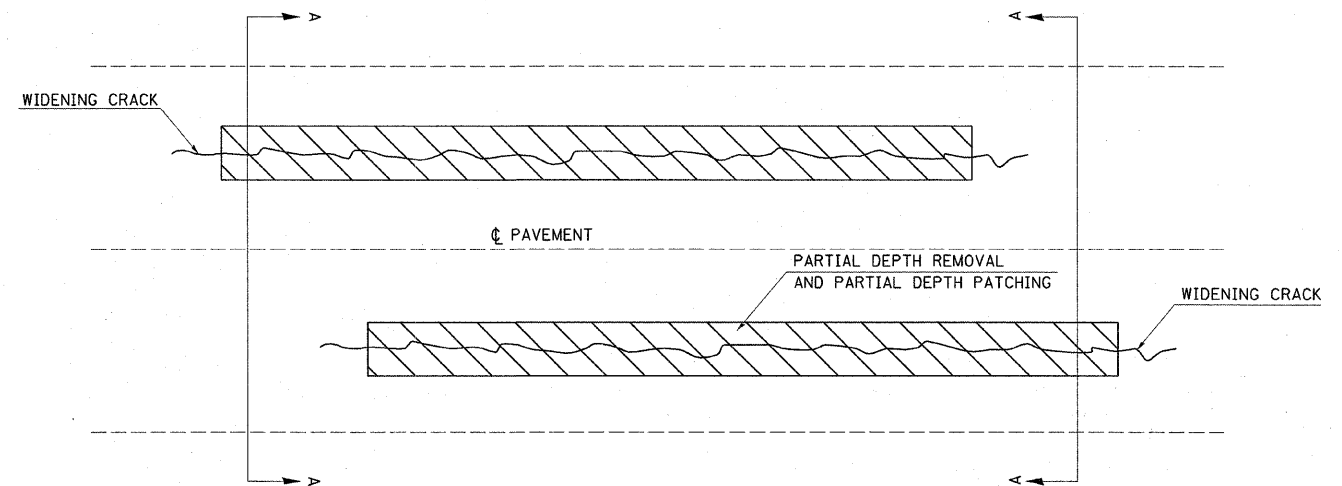

SECTION A-A

NOTE: THE MINIMUM WIDTH FOR PARTIAL DEPTH REMOVAL SHALL BE 24".

• (F-X)RS-1, (113,120)RS-1

FILE NAME =	USER NAME = swartzw	DESIGNED -	REVISED -	STATE OF ILLINOIS DEPARTMENT OF TRANSPORTATION	CONSTRUCTION DETAILS			F.A.P. RTE.	SECTION	COUNTY	TOTAL SHEETS	SHEET NO.
c:\pwork\PW1001\SWARTZRW\d0147989\d7	4410-shd-details.dgn	DRAWN -	REVISED -					116	*	CUMBERLAND	25	9
	PLOT SCALE = 20.0000' / IN.	CHECKED -	REVISED -					CONTRACT NO. 74410				
	PLOT DATE = 1/21/2010	DATE -	REVISED -					FED. ROAD DIST. NO. ILLINOIS FED. AID PROJECT				