

EXISTING TYPICAL SECTION
PARK AVENUE

STATION:
14+76 TO 49+04

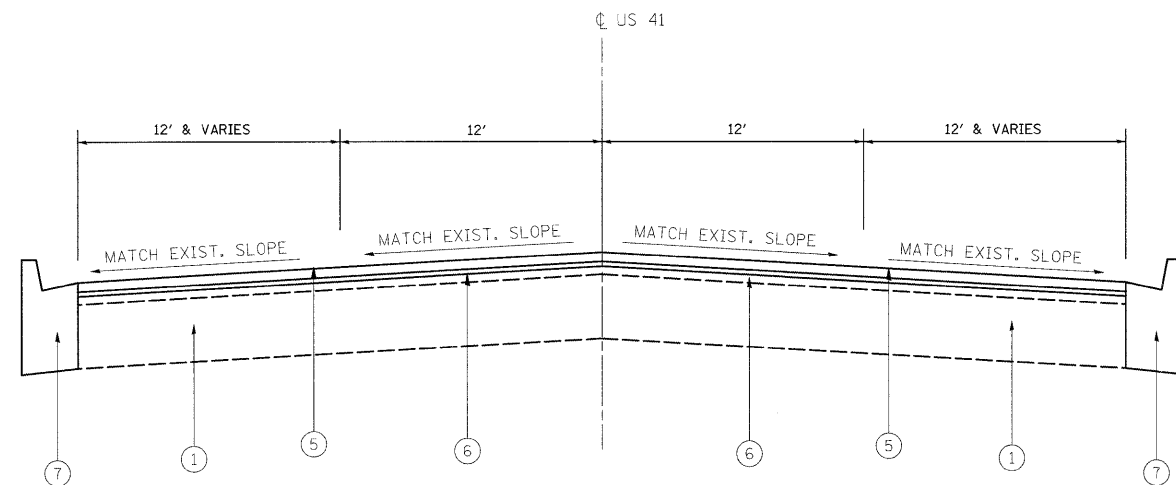

PROPOSED TYPICAL SECTION
PARK AVENUE

STATION:
14+76 TO 49+04

LEGEND

- ① EXIST. PCC BASE COURSE, 9''(±)
- ② EXIST. HOT-MIX ASPHALT SURFACE COURSE (BEFORE MILLING), 4 1/2''(±)
- ③ EXIST. CONCRETE CURB AND GUTTER
- ④ PROP. HOT-MIX ASPHALT SURFACE REMOVAL - 2 1/4''
(2 1/4'' OF HOT-MIX ASPHALT TO REMAIN)
- ⑤ PROP. POLYMERIZED HOT-MIX ASPHALT SURFACE COURSE, MIX "D",
N70, 1 3/4''
- ⑥ PROP. POLYMERIZED LEVELING BINDER (MM), IL-4.75, N50, 3/4''
- ⑦ PROP. CONCRETE CURB AND GUTTER REMOVAL AND REPLACEMENT
(LOCATIONS TO BE DETERMINED BY THE RESIDENT ENGINEER)

FILE NAME =	USER NAME = mitchell-f	DESIGNED -	REVISED -	STATE OF ILLINOIS DEPARTMENT OF TRANSPORTATION	PARK AVENUE : IL 1 /VINCENNES RD TO 154TH ST EXISTING AND PROPOSED TYPICAL SECTIONS	F.A.U. RTE.	SECTION	COUNTY	TOTAL SHEETS	SHEET NO.
ct:\pw\work\pwwid\mitchell-f\d0137633\01	6506-shr-plan.dgn	DRAWN -	REVISED -			3597	163RS	COOK	20	4
	PLOT SCALE = 50.5122' / IN.	CHECKED -	REVISED -			CONTRACT NO. 60A52				
	PLOT DATE = 4/17/2009	DATE -	REVISED -			ILLINOIS FED. AID PROJECT				
				SCALE:	SHEET NO. OF SHEETS	STA.	TO STA.			