

PROPOSED TYPICAL CROSS SECTION

STA. 35+69 TO 57+46  
 STA. 62+39 TO 84+67  
 STA. 88+32 TO 136+79  
 STA. 167+00 TO 191+69

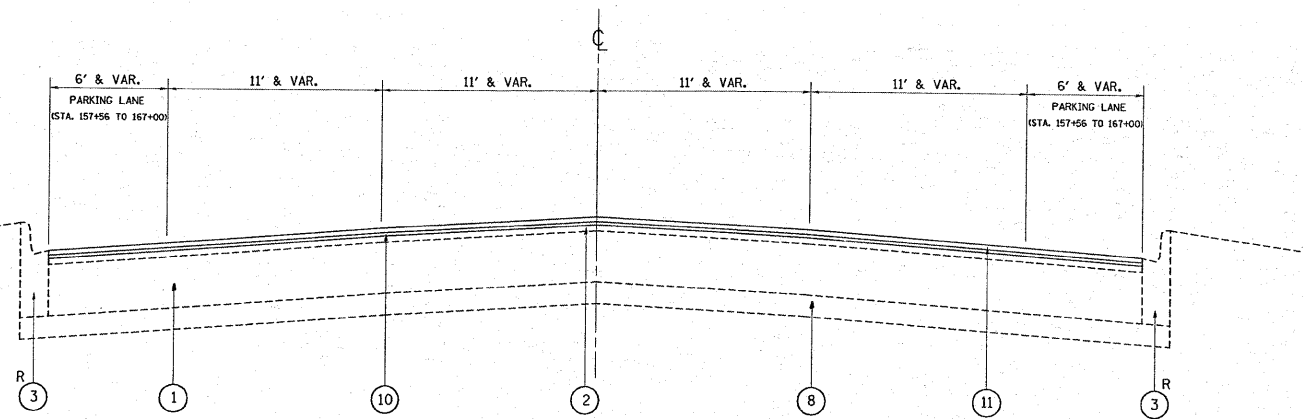

PROPOSED TYPICAL CROSS SECTION

STA. 142+47 TO 146+25  
 STA. 157+56 TO 167+00

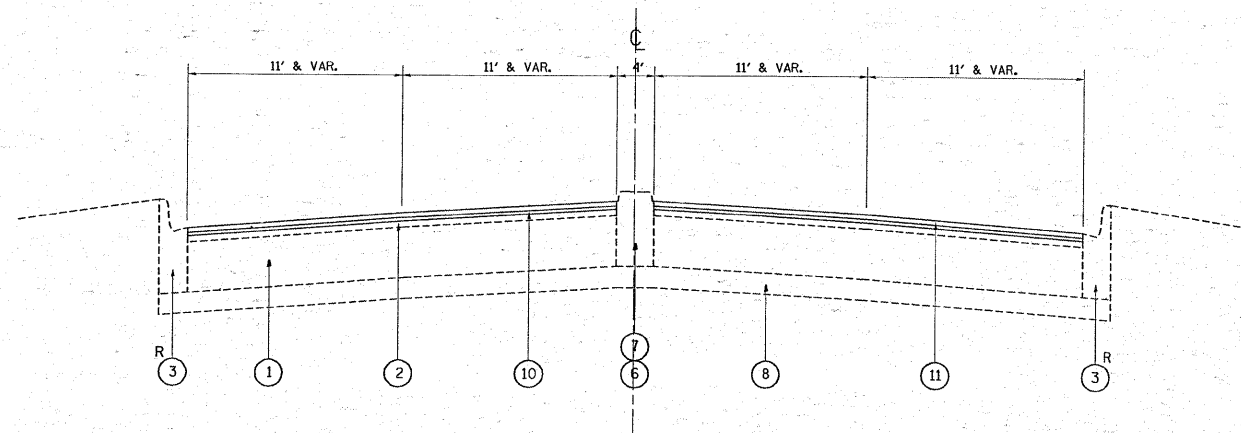

PROPOSED TYPICAL CROSS SECTION

STA. 146+25 TO 157+56

**LEGEND:**

- ① EXIST. P.C.C. PAVEMENT, ±9"
  - ② EXIST. HOT-MIX ASPHALT SURFACE, ±3"
  - ③ EXIST. COMB. CONC. CURB AND GUTTER, TYPE B-6.12
  - ④ EXIST. P.C.C. SIDEWALK
  - ⑤ EXIST. P.C.C. SHOULDER, 10'
  - ⑥ EXIST. CORRUGATED MEDIAN
  - ⑦ EXIST. BARRIER MEDIAN
  - ⑧ EXIST. STABILIZED SUB-BASE
  - ⑨ PROP. HOT-MIX ASPHALT SURFACE REMOVAL, 2 1/4"
  - ⑩ PROP. POLYMERIZED LEVELING BINDER (MACHINE METHOD), SUPERPAVE, IL-4.75, N50, 3/4"
  - ⑪ PROP. HOT-MIX ASPHALT SURFACE COURSE, MIX "D", N70, 1 1/2"
- R CURB AND GUTTER AND SIDEWALK REMOVAL AND REPLACEMENT  
 (LOCATION AS DIRECTED BY THE ENGINEER)

FILE NAME =	USER NAME = s teedpa	DESIGNED -	REVISED -	<b>STATE OF ILLINOIS DEPARTMENT OF TRANSPORTATION</b>	EXISTING AND PROPOSED TYPICAL SECTIONS MONTROSE AVE.--FOREST PRESERVE RD. TO PULASKI RD.	F.A.U. RTE.	SECTION	COUNTY	TOTAL SHEETS	SHEET NO.
c:\pwork\pwork\stedpa\0100515\0137306-sh1-plan.dgn	DRAWN -	REVISED -	1366			0101RS-5	COOK	34	7	
PLOT SCALE = 50.0000' / IN.	CHECKED -	REVISED -	CONTRACT NO. 60B60							
PLOT DATE = 3/25/2009	DATE -	REVISED -	FED. ROAD DIST. NO. 1 [ILLINOIS] FED. AID PROJECT							
					SCALE:	SHEET NO. OF SHEETS STA. TO STA.				