

IL. 21 (MILWAUKEE AVE)

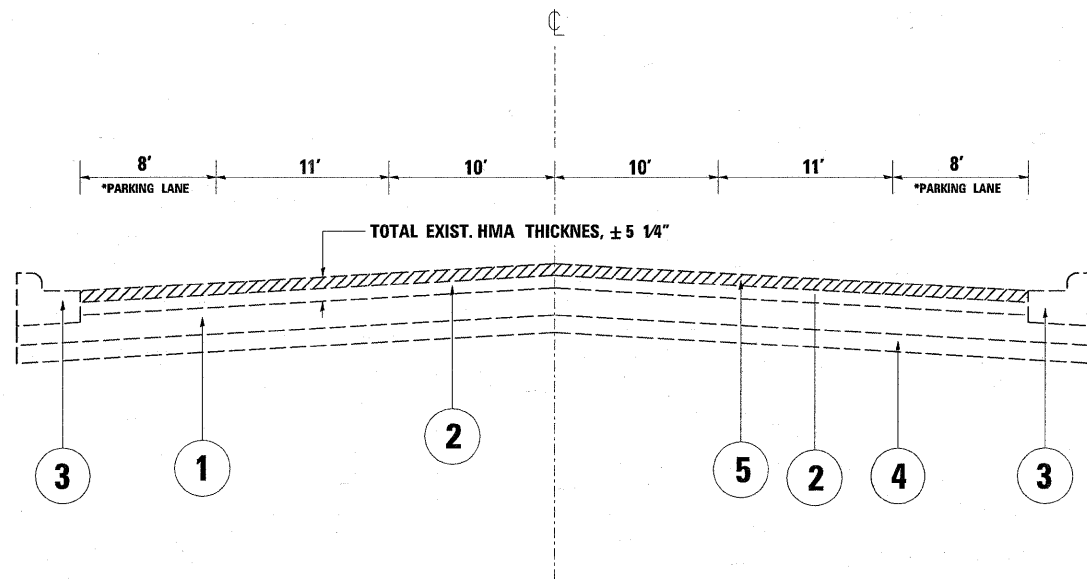

EXIST. TYPICAL SECTION

IL. 21
STA. 05+90 TO 18+00

IL. 21 (MILWAUKEE)

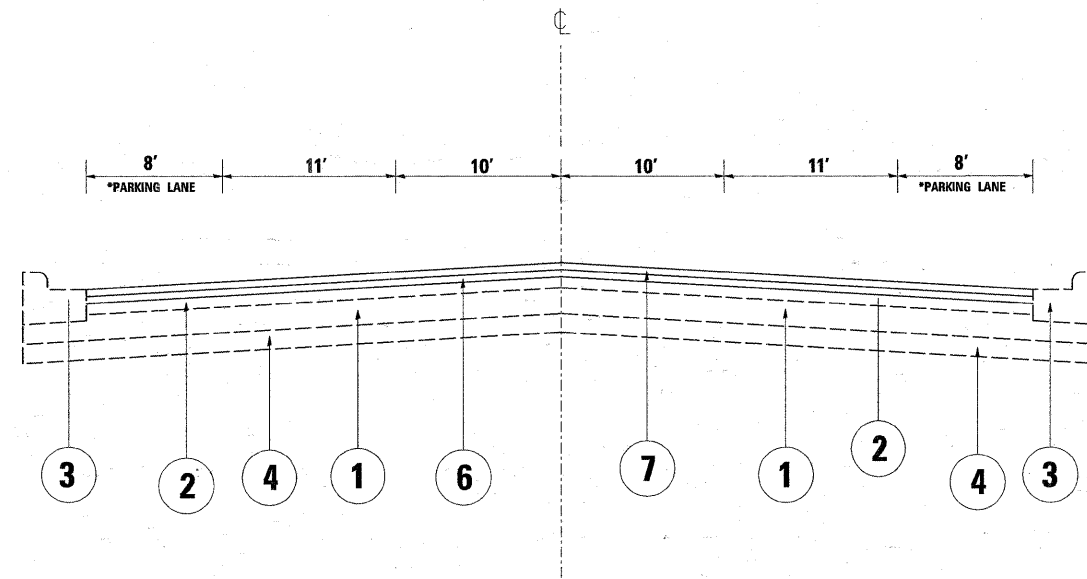

PROP. TYPICAL SECTION

IL. 21
STA. 05+90 TO 18+00

LEGEND

- ① EXISTING PCC BASE COURSE, ± 7"
- ② EXISTING HOT-MIX ASPHALT AFTER MILLING, ± 2 3/4"
- ③ EXISTING COMB. CURB AND GUTTER
- ④ EXISTING SUB-BASE GRANULAR MATERIAL, TYPE B, 4"
- ⑤ PROP. HMA SURFACE REMOVAL, 2 1/4"
- ⑥ PROP. POLY. LEVELING BINDER (MACHINE METHOD), IL-4.75, N50, 3/4"
- ⑦ PROP. HOT-MIX ASPHALT SURFACE COURSE, MIX "D", N70, 1 1/2"

NOTE:

THE CONTRACTOR SHALL MILL FIRST BEFORE PATCHING
*PARKING SPACE
ON THE RIGHT STA. 5+90 TO STA. 15+62
ON THE LEFT STA. 5+90 TO STA. 18+00

FILE NAME =	USER NAME = estumoblek	DESIGNED -	REVISED -	STATE OF ILLINOIS DEPARTMENT OF TRANSPORTATION	IL. 21 (MILWAUKEE AVE.) [IL. 137 (BUCKLEY RD.) TO CHURCH ST.] EXISTING AND PROPOSED TYPICAL SECTIONS	F.A.P. RTE.	SECTION	COUNTY	TOTAL SHEETS	SHEET NO.	
ct\pw_work\PW\DOT\ESTIMABLE\cms88969\sh_rdwg.dgn	PLOT SCALE = 50.0000' / IN.	DRAWN -	REVISED -			330	128 RS-4	LAKE	23	5	
PLOT DATE = 3/19/2009	DATE -	CHECKED -	REVISED -			CONTRACT NO. 60F30					
						SCALE:	SHEET NO. 2 OF 2 SHEETS	STA.	TO STA.	FED. ROAD DIST. NO.	ILLINOIS FED. AID PROJECT