

EXISTING TYPICAL SECTION
STA. 200+38 TO STA. 208+09

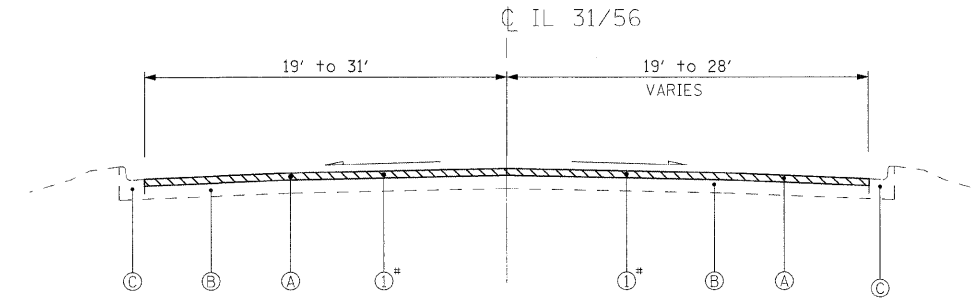

EXISTING TYPICAL SECTION
STA. 224+67 TO STA. 254+27

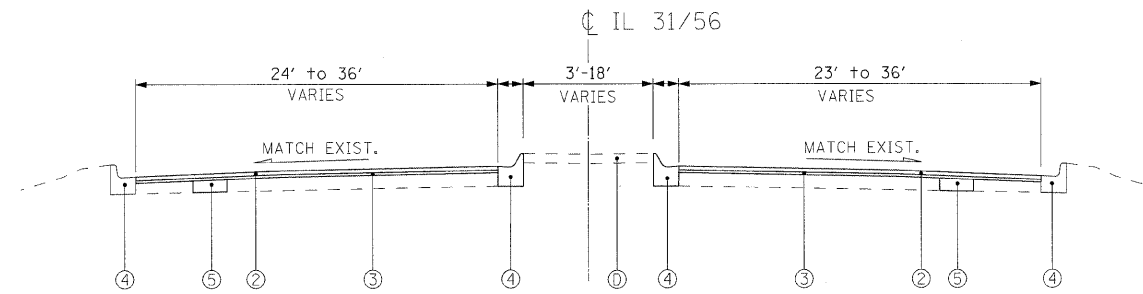

PROPOSED TYPICAL SECTION
STA. 200+38 TO STA. 208+09

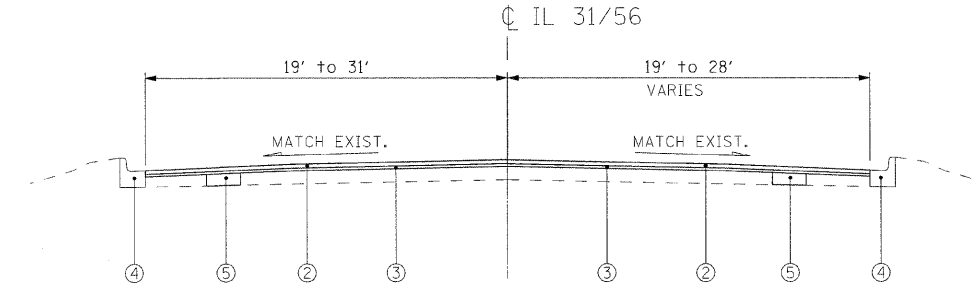

PROPOSED TYPICAL SECTION
STA. 224+67 TO STA. 254+27

HOT-MIX ASPHALT MIXTURE REQUIREMENTS CHART

OPERATIONS	MIXTURE TYPE	AC TYPE	PERCENT AIR VOIDS
ROADWAY RESURFACING	POLYMERIZED HOT-MIX ASPHALT SURFACE COURSE, MIX "F", N90 (IL-9.5MM)	SBS/SBR PG 70-22	4% @ 90 GYR
	POLYMERIZED LEVELING BINDER (MACHINE METHOD), IL-4.75, N50	SBS/SBR PG 76-28/-22	4% @ 50 GYR
MAINTENANCE OF TRAFFIC	LEVELING BINDER (HAND METHOD), N70 (IL-9.5MM)	PG 64-22 *	4% @ 70 GYR
PAVEMENT PATCHING	CLASS D PATCHES, 13" (HMA BINDER IL-19 MM)	PG 64-22 *	4% @ 70 GYR
DRIVES BEHIND CURB	HOT-MIX ASPHALT SURFACE COURSE MIX "C", N50 (IL-9.5MM)	PG 64-22 *	4% @ 50 GYR
	HOT-MIX ASPHALT BASE COURSE, 8" (HMA BINDER IL-19 MM)	PG 64-22/58-22	4% @ 50 GYR

THE UNIT WEIGHT USED TO CALCULATE ALL HMA SURFACE MIXTURE QUANTITIES IS 112 LBS/SO YD/IN.

* WHEN RAP EXCEEDS 20%, THE NEW ASPHALT BINDER IN THE MIX SHALL BE PG 58-22.

EXISTING CONDITIONS:

- (A) HOT-MIX ASPHALT SURFACE AND BINDER COURSE, 5" AND VARIES
- (B) PORTLAND CEMENT CONCRETE BASE COURSE, 10"
- (C) COMBINATION CONCRETE CURB AND GUTTER
- (D) RAISED CONCRETE MEDIAN

PROPOSED IMPROVEMENTS:

- (1) HOT-MIX ASPHALT SURFACE REMOVAL, 2 1/2"
- (2) POLYMERIZED HOT-MIX ASPHALT SURFACE COURSE, MIX "F", N90, 1 3/4"
- (3) POLYMERIZED LEVELING BINDER (MACHINE METHOD), IL-4.75, N50, 3/4"
- (4) COMBINATION CONCRETE CURB AND GUTTER REMOVAL AND REPLACEMENT (AS DIRECTED BY ENGINEER)
- (5) CLASS D PATCHES, 13" (DETERMINED BY ENGINEER IN FIELD)

* THE CONTRACTOR SHALL MILL FIRST BEFORE PATCHING

A QUANTITY FOR LEVELING BINDER (HAND METHOD) HAS BEEN PROVIDED FOR USE AT PRIVATE ENTRANCES, AROUND HAND HOLES, PRIVATE UTILITY STRUCTURE FRAMES, AND ANY OTHER STRUCTURE FRAMES THAT ARE NOT ABLE TO BE LOWERED UNDER THE ITEM "FRAMES AND LIDS TO BE ADJUSTED (SPECIAL)" AFTER GRINDING OF EXISTING PAVEMENT.

FILE NAME = m:\p\3365\3365_08\design\proposed\3365_08-04-Typical Sections.dgn