

EXISTING TYPICAL CROSS SECTION
STA. 73+92 TO 75+93
STA. 98+18 TO 101+90

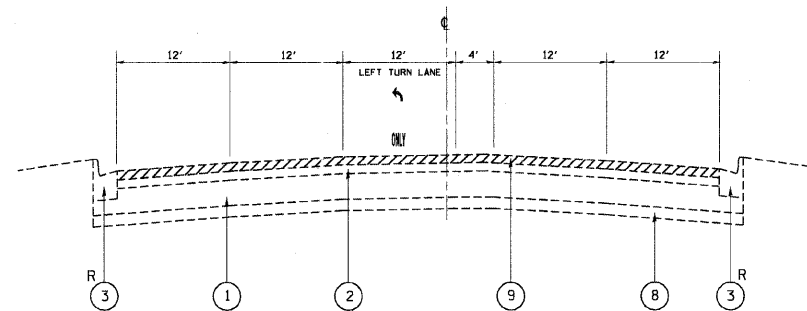

EXISTING TYPICAL CROSS SECTION
STA. 103+28 TO 106+58
STA. 113+30 TO 118+15

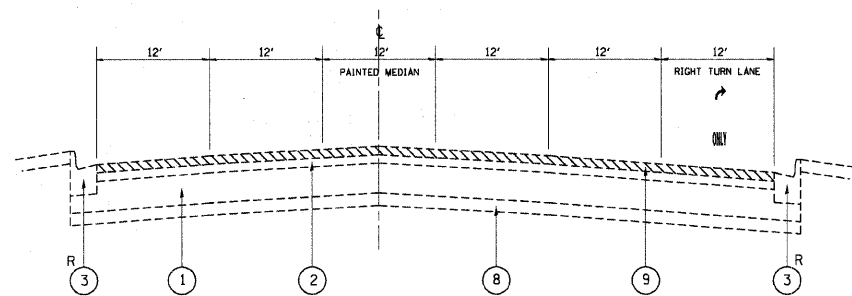

EXISTING TYPICAL CROSS SECTION
STA. 75+93 TO 79+64

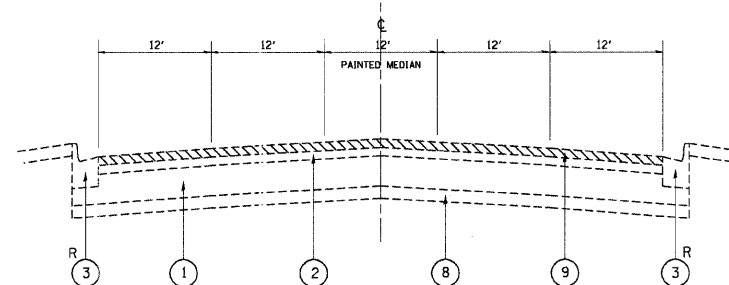

EXISTING TYPICAL CROSS SECTION
STA. 106+58 TO 110+59
STA. 118+15 TO 120+60

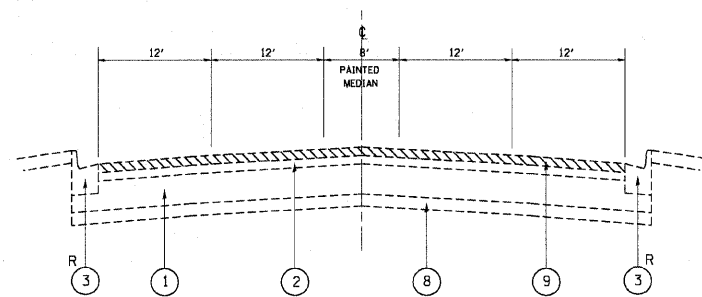

EXISTING TYPICAL CROSS SECTION
STA. 79+64 TO 98+18

LEGEND:

- ① EXIST. P.C.C. PAVEMENT, ±10"
 - ② EXIST. HOT-MIX ASPHALT SURFACE, ±3"
 - ③ EXIST. COMB. CONC. CURB AND GUTTER, TYPE B-6.12
 - ④ EXIST. P.C.C. SIDEWALK
 - ⑤ EXIST. BARRIER MEDIAN
 - ⑥ EXIST. CORRUGATED MEDIAN
 - ⑦ EXIST. LANDSCAPE MEDIAN
 - ⑧ EXIST. STABILIZED SUB-BASE
 - ⑨ PROP. HOT-MIX ASPHALT SURFACE REMOVAL, 2 1/2"
 - ⑩ PROP. POLYMERIZED LEVELING BINDER (MACHINE METHOD), SUPERPAVE, IL-4.75, N50, 3/4"
 - ⑪ PROP. POLYMERIZED HOT-MIX ASPHALT SURFACE COURSE, MIX "F", N90, 1 1/4"
- R CURB AND GUTTER REMOVAL AND REPLACEMENT
(LOCATION AS DIRECTED BY THE ENGINEER)

FILE NAME =	USER NAME = leyo	DESIGNED -	REVISED -
C:\pwork\KAPWIDOT\STEEDPA\0813722\0132209.sht.plt.dgn		DRAWN -	REVISED -
		CHECKED -	REVISED -
		DATE -	REVISED -

**STATE OF ILLINOIS
DEPARTMENT OF TRANSPORTATION**

EXISTING TYPICAL SECTIONS		F.A.P. RTE.	SECTION	COUNTY	TOTAL SHEETS	SHEET NO.
US 52 (JEFFERSON ST.)--JOYCE RD. TO EDEN LN.		607	128 RS-5	WILL	29	4
SCALE:	SHEET NO. OF SHEETS	STA.	TO STA.		CONTRACT NO. 60666	
		FED. ROAD DIST. NO. 1 ILLINOIS FED. AID PROJECT				