

PROPOSED TYPICAL CROSS SECTION
STA. 110+59 TO 112+34

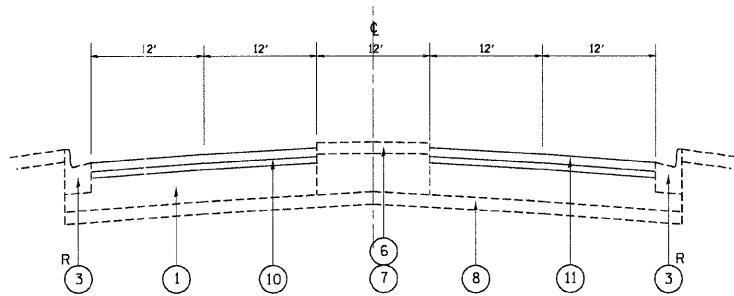

PROPOSED TYPICAL CROSS SECTION
STA. 127+36 TO 128+89

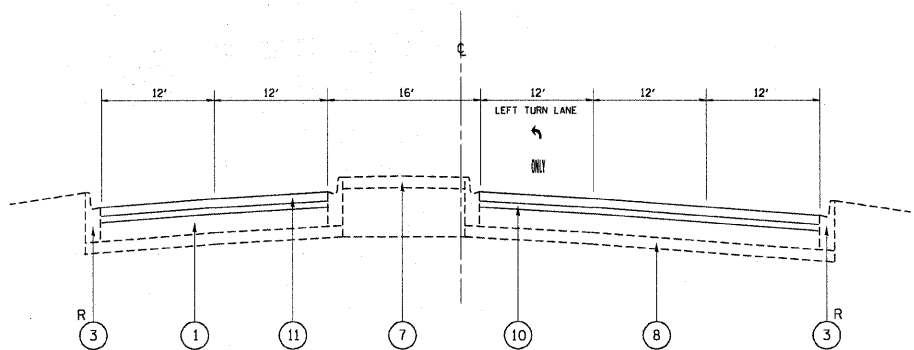

PROPOSED TYPICAL CROSS SECTION
STA. 120+60 TO 122+12

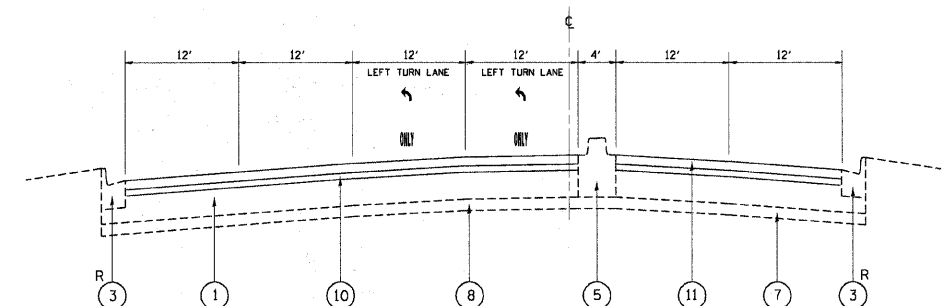

PROPOSED TYPICAL CROSS SECTION
STA. 123+06 TO 127+36

LEGEND:

- ① EXIST. P.C.C. PAVEMENT, ±10"
 - ② EXIST. HOT-MIX ASPHALT SURFACE, ±3"
 - ③ EXIST. COMB. CONC. CURB AND GUTTER, TYPE B-6.12
 - ④ EXIST. P.C.C. SIDEWALK
 - ⑤ EXIST. BARRIER MEDIAN
 - ⑥ EXIST. CORRUGATED MEDIAN
 - ⑦ EXIST. LANDSCAPE MEDIAN
 - ⑧ EXIST. STABILIZED SUB-BASE
 - ⑨ PROP. HOT-MIX ASPHALT SURFACE REMOVAL, 2 1/2"
 - ⑩ PROP. POLYMERIZED LEVELING BINDER (MACHINE METHOD), SUPERPAVE, IL-4.75, N50, 3/4"
 - ⑪ PROP. POLYMERIZED HOT-MIX ASPHALT SURFACE COURSE, MIX "F", N90, 1 3/4"
- R CURB AND GUTTER REMOVAL AND REPLACEMENT
(LOCATION AS DIRECTED BY THE ENGINEER)

FILE NAME =	USER NAME = lsgso	DESIGNED -	REVISED -
C:\pwork\p\DOT\STEEDPA\0137220\DIS2209-shr-plendgn		DRAWN -	REVISED -
		CHECKED -	REVISED -
		DATE -	REVISED -

DESIGNED -	REVISED -
DRAWN -	REVISED -
CHECKED -	REVISED -
DATE -	REVISED -

**STATE OF ILLINOIS
DEPARTMENT OF TRANSPORTATION**

PROPOSED TYPICAL SECTIONS			
US 52 (JEFFERSON ST.)--JOYCE RD. TO EDEN LN.			
SCALE:	SHEET NO.	OF SHEETS	STA. TO STA.

F.A.P. RTE.	SECTION	COUNTY	TOTAL SHEETS	SHEET NO.
607	128 RS-5	WILL	29	7
FED. ROAD DIST. NO. 1 ILLINOIS FED. AID PROJECT				

CONTRACT NO. 60666