

**ILL RTE 25
EXIST. TYPICAL SECTION**
STA. 90+77 TO STA. 102+11

LEGEND

- ① EXIST. PCC BASE COURSE, (±)9"
- ② EXIST. REMAINING HMA AFTER MILLING, (±)5"
- ③ EXIST. AGGREGATE SHOULDER
- ④ EXIST. COMBINATION CONCRETE CURB AND GUTTER TYPE B-6.24
- ⑤ PROP. HOT-MIX ASPHALT SURFACE REMOVAL - 2 1/4"
- ⑥ PROP. HOT-MIX ASPHALT SURFACE COURSE, MIX "D", N70, 1 1/2"
- ⑦ PROP. POLYMERIZED LEVELING BINDER (MM), IL-4.75, N50, 3/4"
- ⑧ PROP. AGGREGATE WEDGE SHOULDER, TYPE B

NOTE: CONTRACTOR SHALL MILL FIRST BEFORE PATCHING

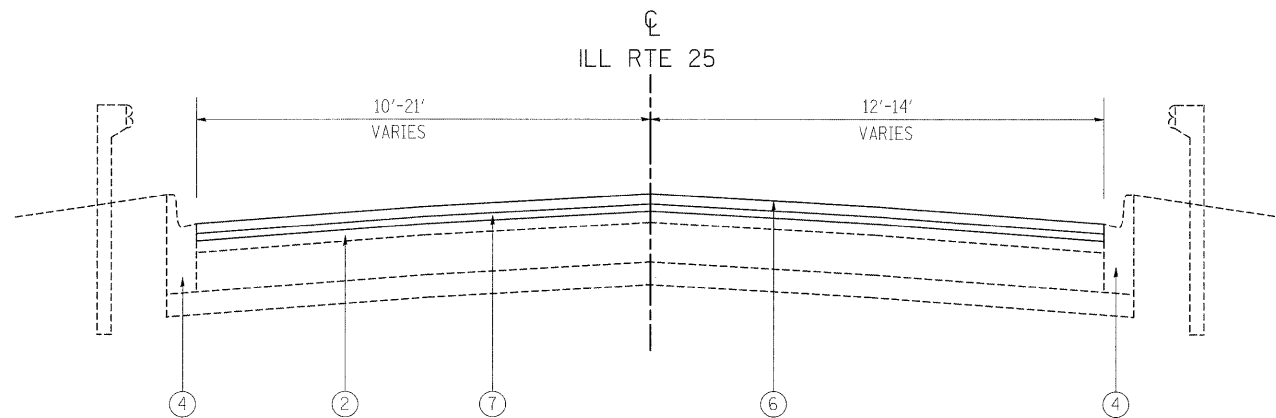

**ILL RTE 25
PROP. TYPICAL SECTION**
STA. 90+77 TO STA. 118+12

FILE NAME =	USER NAME = guillaumeff	DESIGNED -	REVISED -	STATE OF ILLINOIS DEPARTMENT OF TRANSPORTATION	ILL RTE 25 TYPICAL SECTIONS	F.A.U. RTE. 2503	SECTION TWP-2-RS-2	COUNTY KANE	TOTAL SHEETS 19	SHEET NO. 5	
cs:\pwork\pwidot\GUILLAUMEFF\0137752	D152409-sht-plan.dgn	DRAWN -	REVISED -			SCALE:	SHEET NO. OF SHEETS STA. TO STA.	FED. ROAD DIST. NO. 1 ILLINOIS FED. AID PROJECT			
	PLOT SCALE = 50,0000 ' / IN.	CHECKED -	REVISED -					CONTRACT NO. 60G68			
	PLOT DATE = 4/23/2009	DATE -	REVISED -								