

F.A.I. RTE.	SECTION	COUNTY	TOTAL SHEETS	SHEET NO.
55	22-1AC-RS-2	DUPAGE	10	1
D-91-557-09		ILLINOIS	CONTRACT NO. 60H01	

STATE OF ILLINOIS  
DEPARTMENT OF TRANSPORTATION  
DIVISION OF HIGHWAYS

PROPOSED HIGHWAY PLANS

F.A.I. 55 /I-55 (FRONTAGE RD.)

WILL COUNTY LINE TO WOODWARD AVE

SECTION: 22-1AC-RS-2

RESURFACING

DUPAGE COUNTY

C-91-557-09

FOR INDEX OF SHEETS, SEE SHEET NO. 2

IMPROVEMENT LOCATED IN  
THE VILLAGE OF WOODRIDGE

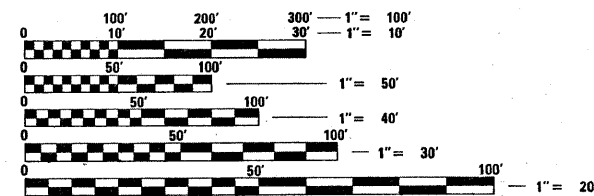

FULL SIZE PLANS HAVE BEEN PREPARED USING STANDARD ENGINEERING SCALES. REDUCED SIZED PLANS WILL NOT CONFORM TO STANDARD SCALES. IN MAKING MEASUREMENTS ON REDUCED PLANS, THE ABOVE SCALES MAY BE USED.

J.U.L.I.E.  
JOINT UTILITY LOCATION INFORMATION FOR EXCAVATION  
1-800-892-0123  
OR 811

PROJECT ENGINEER: JENPAI CHANG 847-705-4432  
PROJECT MANAGER: KEN ENG

CONTRACT NO. 60H01

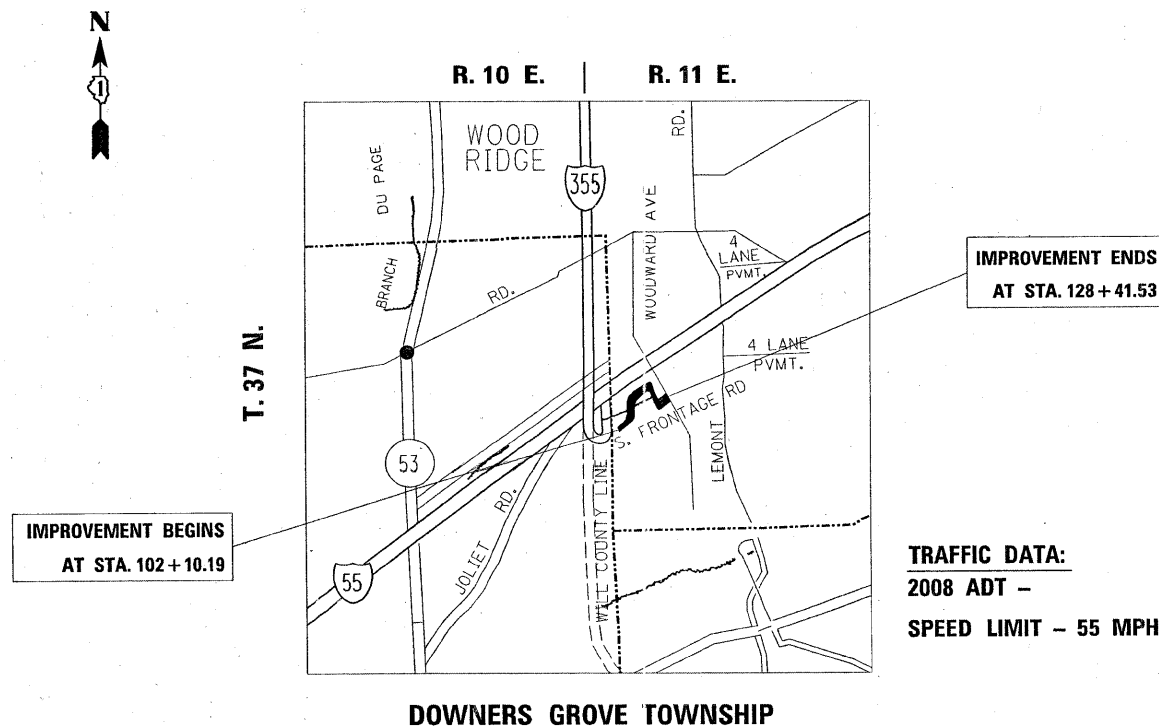
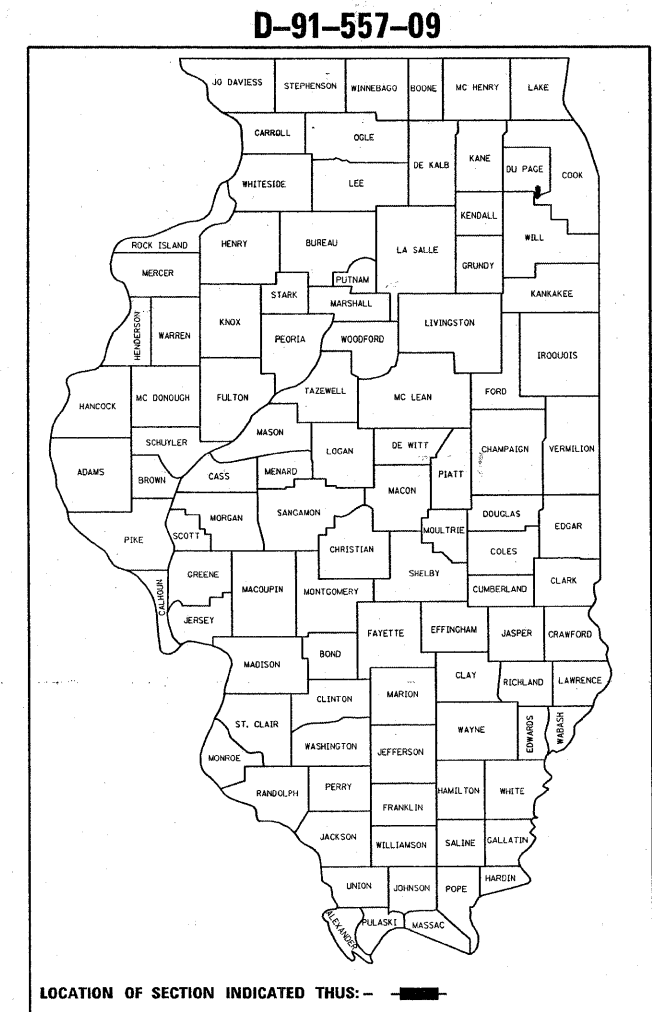

TRAFFIC DATA:  
2008 ADT -  
SPEED LIMIT - 55 MPH

STATE OF ILLINOIS  
DEPARTMENT OF TRANSPORTATION  
DIVISION OF HIGHWAYS

SUBMITTED APRIL 22, 2009

Diana M. O'Keefe  
DEPUTY DIRECTOR OF HIGHWAYS, REGION ENGINEER

May 1, 2009  
Charles G. Ingersoll  
ENGINEER OF DESIGN AND ENVIRONMENT

May 1, 2009  
Christine M. Reed  
DIRECTOR OF HIGHWAYS, CHIEF ENGINEER

PRINTED BY THE AUTHORITY  
OF THE STATE OF ILLINOIS

GROSS AND NET LENGTH OF IMPROVEMENT = 2631.34 FT. = .50 MILES

SHEET NO.      INDEX OF SHEETS DESCRIPTION

1	COVER SHEET
2	INDEX OF SHEETS, STATE STANDARDS, AND GENERAL NOTES
3	SUMMARY OF QUANTITIES
4	TYPICAL SECTIONS
5	ROADWAY AND PAVEMENT MARKING PLANS
6	BUTT JOINT AND HMA TAPER DETAILS (BD-32)
7	TRAFFIC CONTROL AND PROTECTION FOR SIDE ROADS, INTERSECTIONS, AND DRIVEWAYS (TC-10)
8	TYPICAL APPLICATIONS FOR RAISED REFLECTIVE PAVEMENT MARKERS (TC-11)
9	DISTRICT ONE TYPICAL PAVEMENT MARKINGS (TC-13)
10	ARTERIAL ROAD INFORMATION SIGNING (TC-22)

STATE STANDARDS

000001-05 STANDARD SYMBOLS, ABBREVIATIONS AND PATTERNS  
 701301-03 LANE CLOSURE 2L, 2W SHORT TIME OPERATIONS  
 701306-02 LANE CLOSURE 2L, 2W, SLOW MOVING OPERATIONS DAY ONLY, FOR SPEEDS > 45 MPH  
 701311-03 LANE CLOSURE 2L, 2W, MOVING OPERATIONS-DAY ONLY  
 701901-01 TRAFFIC CONTROL DEVICES  
 781001-03 TYPICAL RAISED REFLECTIVE PAVEMENT MARKERS

GENERAL NOTES

BEFORE STARTING ANY EXCAVATION, THE CONTRACTOR SHALL CALL "JULIE" AT 1-800-892-0123 OR "CUAN" (CHICAGO UTILITY ALERT NETWORK), (312)-744-7000 FOR FIELD LOCATIONS OF BURIED ELECTRIC, TELEPHONE AND GAS FACILITIES. (48 HOUR NOTIFICATION IS REQUIRED)

THE CONTRACTOR SHALL COORDINATE CONSTRUCTION ACTIVITIES WITH UTILITY COMPANIES

THE CONTRACTOR WILL NOT BE ALLOWED TO SET UP A YARD OR FIELD OFFICE ON STATE PROPERTY WITHOUT WRITTEN PERMISSON FROM THE DEPARTMENT.

THE RESIDENT ENGINEER SHALL CONTACT DON CHIARUGI, AT 847-741-9857 A MINIMUM OF 2 WEEKS PRIOR TO THE PLACEMENT OF FINAL PAVEMENT MARKINGS.

THE RESIDENT ENGINEER SHALL CONTACT THE TRAFFIC CONTROL SUPERVISOR AT 847-705-4470 A MINIMUM OF 72 HOURS PRIOR TO THE INSTALLATION OF ANY TEMPORARY TRAFFIC CONTROL DEVICES

HMA TAPERS WILL BE INSTALLED AT THE ENDS OF RESURFACING IN ACCORDANCE WITH THE "BUTT JOINT AND HMA TAPER DETAILS" SHEET INCLUDED IN THE PLANS UNLESS OTHERWISE SPECIFIED

BEFORE BEGINNING ANY WORK, THE CONTRACTOR SHALL RETAIN AND RECORD FOR FUTURE REFERENCE, ALL EXISTING PAVEMENT MARKING LINES (AND RAISED REFLECTIVE PAVEMENT MARKERS) IN ORDER THAT THESE LOCATIONS CAN BE RE-ESTABLISHED FOR STRIPING. EXACT LOCATIONS OF ALL PAVEMENT MARKINGS SHALL BE AS DIRECTED BY THE ENGINEER

FILE NAME =	USER NAME = aqeelff	DESIGNED -	REVISED -	<b>STATE OF ILLINOIS DEPARTMENT OF TRANSPORTATION</b>	<b>INDEX OF SHEETS, STATE STANDARDS, &amp; GENERAL NOTES I-55 FRONTAGE RD.</b>	F.A.I. RTE.	SECTION	COUNTY	TOTAL SHEETS	SHEET NO.
c:\pw_work\pwwdot\aqeelff\0136528\0159\09-sht-pln.dgn	DRAWN -	REVISED -	55			22-1AC-RS-2	DUPAGE	10	2	
PLOT SCALE = 50.0000' / IN.	CHECKED -	REVISED -	CONTRACT NO. 60H01							
PLOT DATE = 4/23/2009	DATE -	REVISED -	SCALE:			SHEET NO. 1 OF 1 SHEETS	STA.	TO STA.	ILLINOIS FED. AID PROJECT	

SUMMARY OF QUANTITIES			URBAN 100% STATE TOTAL QUANTITIES	CONSTRUCTION TYPE CODE					SUMMARY OF QUANTITIES			TOTAL QUANTITIES	CONSTRUCTION TYPE CODE				
CODE NO	ITEM	UNIT		I-000						CODE NO	ITEM		UNIT				
20201006	GRADING AND SHAPING SHOULDERS	UNIT	27	27													
31101300	SUB-BASE GRANULAR MATERIAL, TYPE B 5"	SO YD	4357	4357													
35800100	PREPARATION OF BASE	SO YD	4357	4357													
35800200	AGGREGATE BASE REPAIR	TON	1211	1211													
40600200	BITUMINOUS MATERIALS (PRIME COAT)	TON	2	2													
40600300	AGGREGATE (PRIME COAT)	TON	9	9													
40600895	CONSTRUCTING TEST STRIP	EACH	3	3													
40603085	HOT-MIX ASPHALT BINDER COURSE, IL-19.0, N70	TON	732	732													
40603340	HOT-MIX ASPHALT SURFACE COURSE, MIX "D", N70	TON	366	366													
48102100	AGGREGATE WEDGE SHOULDER, TYPE B	TON	211	211													
67000400	ENGINEER'S FIELD OFFICE, TYPE A	CAL MO	6	6													
67100100	MOBILIZATION	L SUM	1	1													
70100460	TRAFFIC CONTROL AND PROTECTION, STANDARD 701306	L SUM	1	1													
70300100	SHORT-TERM PAVEMENT MARKING	FOOT	3709	3709													
70300220	TEMPORARY PAVEMENT MARKING - LINE 4"	FOOT	6499	6499													
70301000	WORK ZONE PAVEMENT MARKING REMOVAL	SO FT	412	412													
* 78000200	THERMOPLASTIC PAVEMENT MARKING - LINE 4"	FOOT	6499	6499													
* 78100100	RAISED REFLECTIVE PAVEMENT MARKER	EACH	20	20													
X0322256	TEMPORARY INFORMATION SIGNING	SO FT	51.4	51.4													

\* SPECIALITY ITEMS

EXISTING TYPICAL CROSS SECTION

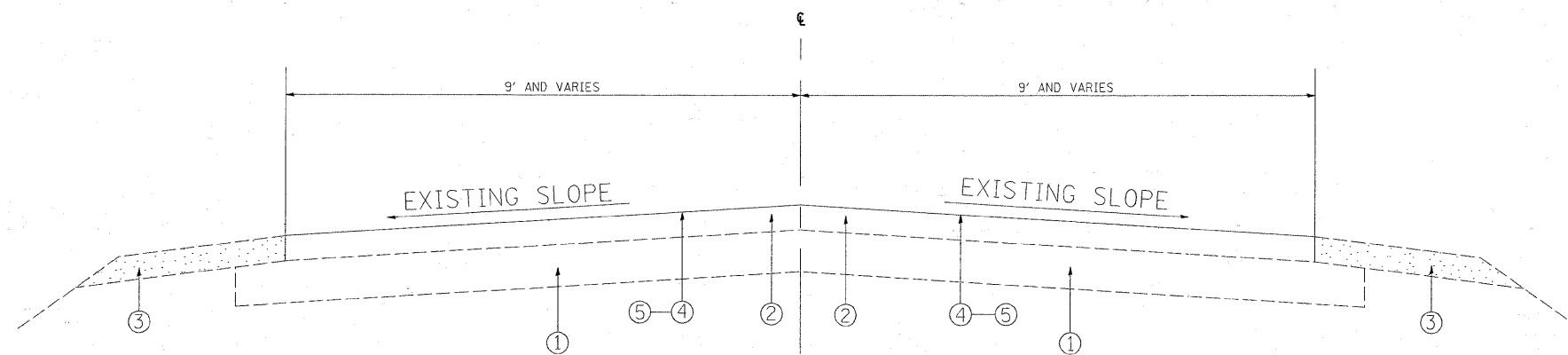

STA. 102+10.19 TO STA. 128+41.53

LEGEND

- ① EXISTING SOIL, (± 8")
- ② EXISTING COMPACTED GRAVEL/CRUSHED STONE BASE COURSE, TYPE A (± 5")
- ③ EXISTING AGGREGATE SHOULDERS
- ④ PROPOSED PREPARATION OF BASE
- ⑤ PROPOSED AGGREGATE BASE REPAIR
- ⑥ PROPOSED HMA SURFACE COURSE, MIX "D", N70, (1 1/2")
- ⑦ PROPOSED HMA BINDER COURSE, IL-19.0, N70 (3")
- ⑧ PROPOSED SUB-BASE GRANULAR MATERIAL, TYPE B, (5")
- ⑨ PROPOSED AGGREGATE WEDGE SHOULDERS, TYPE B
- ⑩ PROPOSED GRADING & SHAPING SHOULDERS

PROPOSED TYPICAL CROSS SECTION

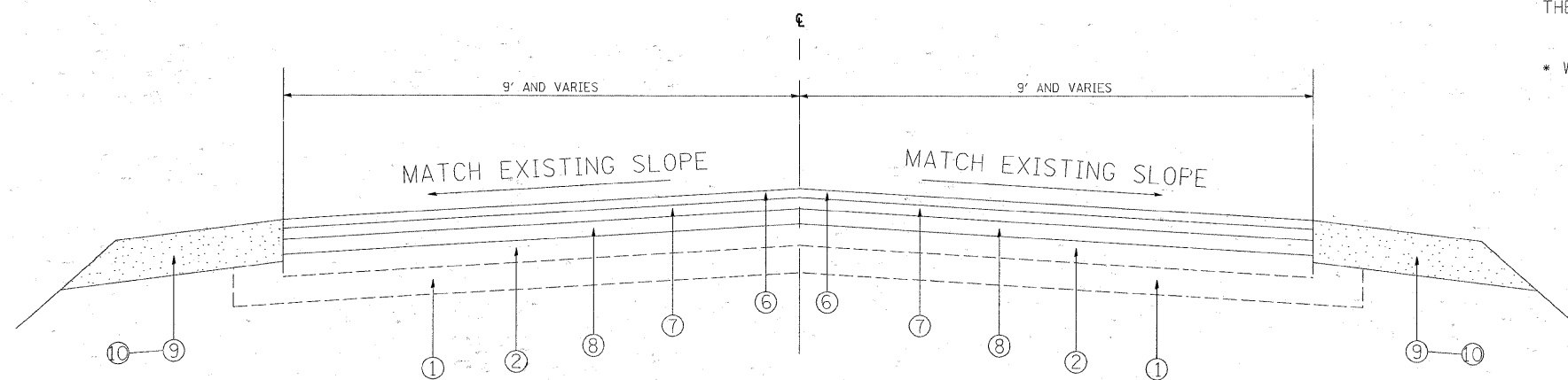

STA. 102+10.19 TO STA. 128+41.53

MIXTURE REQUIREMENTS		
MIXTURE USES	AC / PG	DESIGN AIR VOIDS
HMA SURFACE COURSE, MIX "D", N70 (IL-9.5mm)	PG 64-22	4% AT 70 GYRATIONS
HMA BINDER COURSE, IL-19.0 N70	PG 64-22*	4% AT 70 GYRATIONS

THE UNIT WEIGHT USED TO CALCULATE ALL SURFACE MIXTURE QUANTITIES IS 112 LBS/SY/IN

\* WHEN RAP EXCEEDS 20%, THE NEW ASPHALT BINDER IN THE MIX SHALL BE PG 58-22

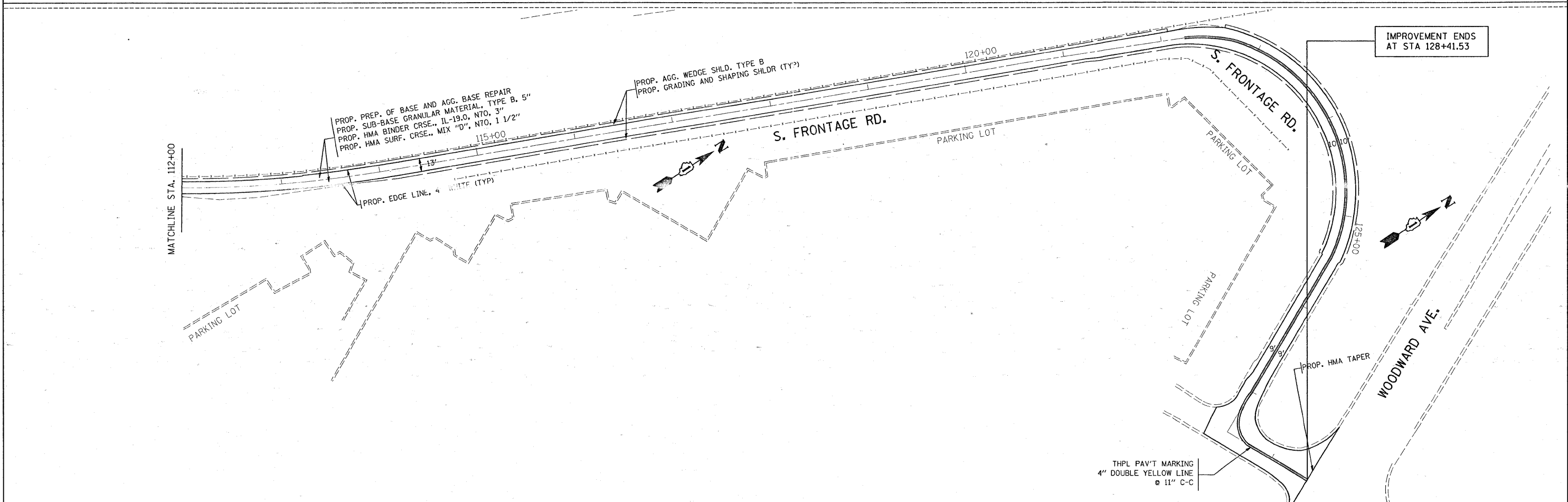
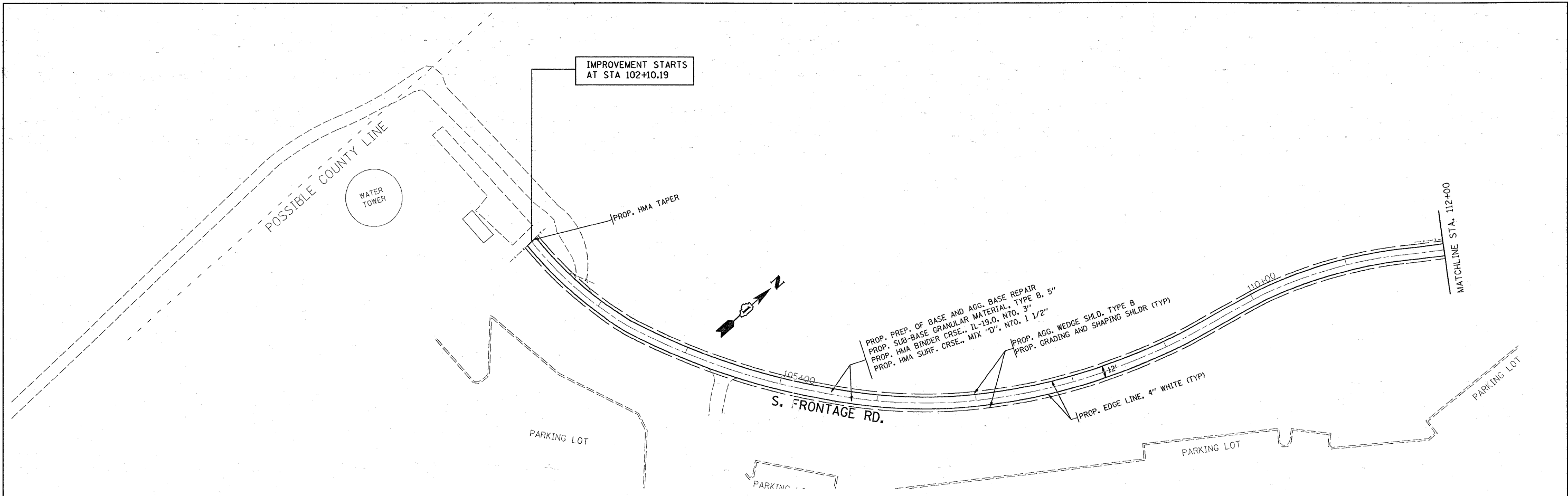

FILE NAME =	USER NAME = equeiff	DESIGNED -	REVISED -	<b>STATE OF ILLINOIS DEPARTMENT OF TRANSPORTATION</b>	<b>SOUTH FRONTAGE ROAD FOR I-55 FROM WILL-DUPAGE LINE TO WOODWARD AVENUE</b>	F.A.I. RTE.	SECTION	COUNTY	TOTAL SHEETS	SHEET NO.	
c:\pw_work\pwsdot\aqueiff\0136528\DI58709\shht-pln.dgn		DRAWN -	REVISED -			55	22-1AC-RS-2	DUPAGE	10	5	
PLOT SCALE = 50.0000' / 1" IN.		CHECKED -	REVISED -			CONTRACT NO. 60H01					
PLOT DATE = 4/23/2009		DATE -	REVISED -			ILLINOIS FED. AID PROJECT					

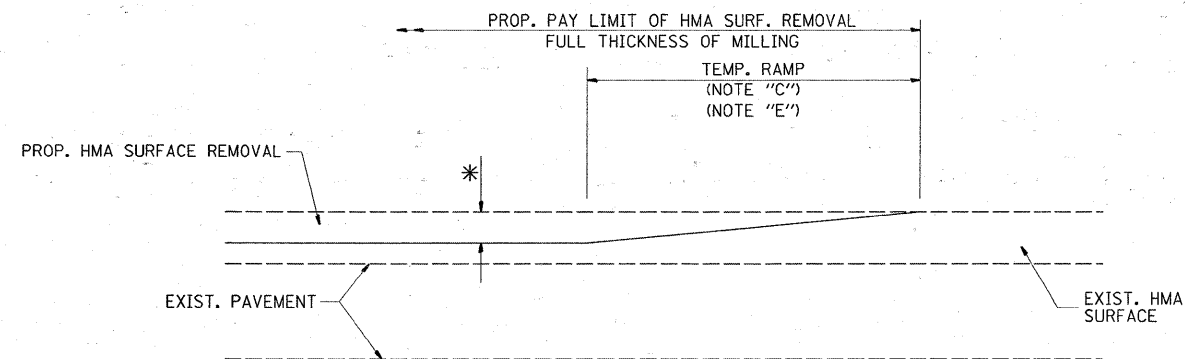

MILLED TEMPORARY RAMP  
(FOR BUTT JOINT AND HMA TAPER SEE DETAIL BELOW)

OPTION 1

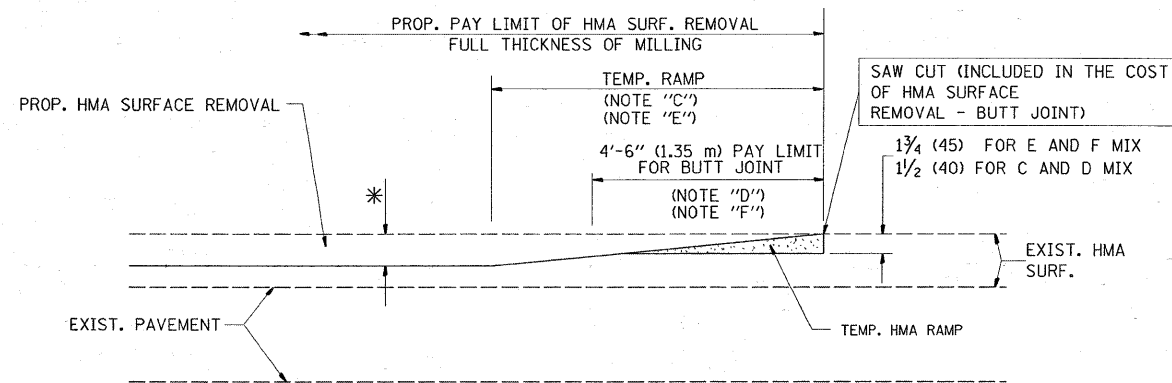

HMA CONSTRUCTED TEMPORARY RAMP  
(FOR BUTT JOINT AND HMA TAPER SEE DETAIL BELOW)

OPTION 2

TYPICAL TEMPORARY RAMP

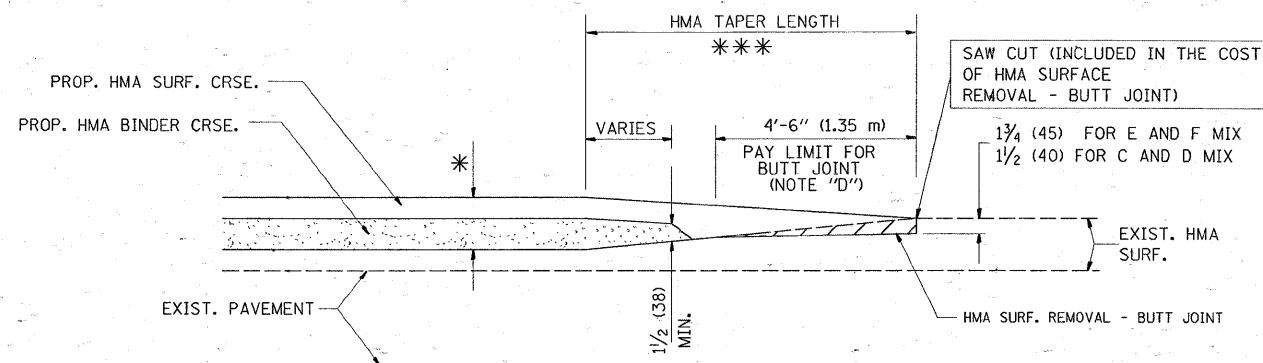

BUTT JOINT AND  
HMA TAPER

TYPICAL BUTT JOINT AND HMA TAPER  
FOR MILLING AND RESURFACING

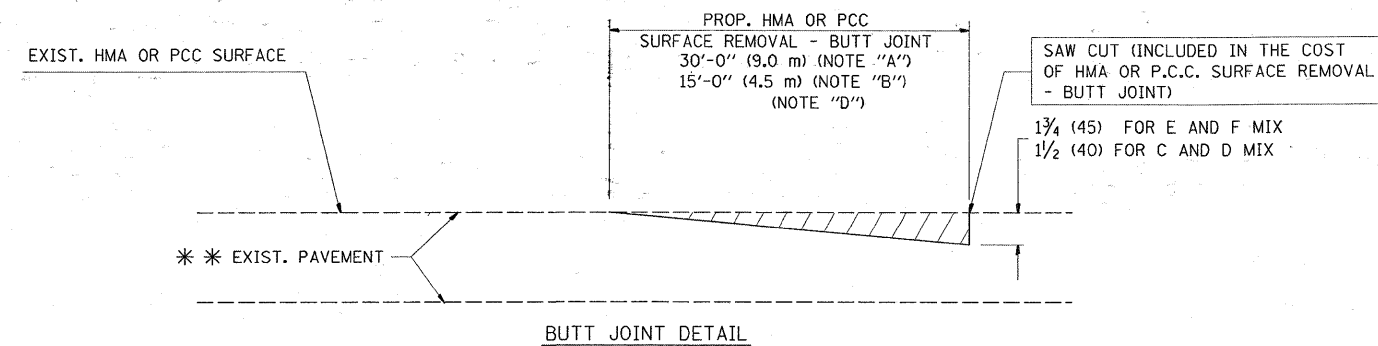

BUTT JOINT DETAIL

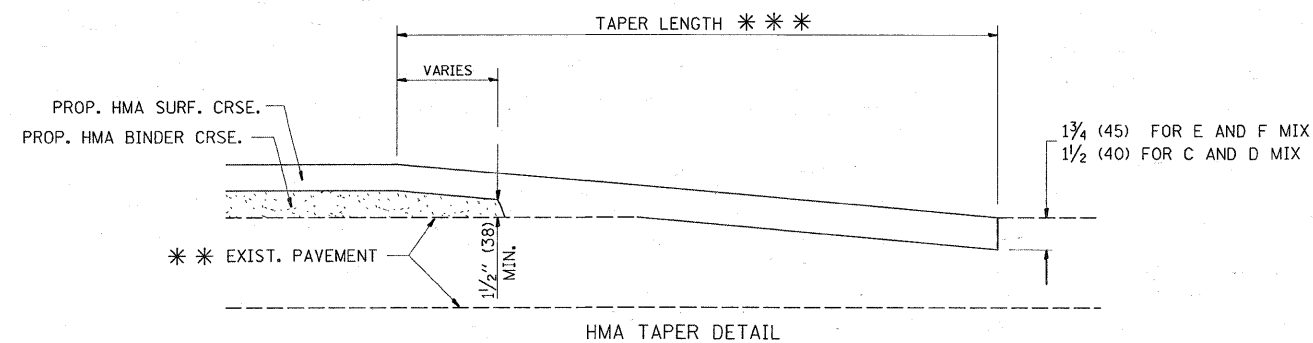

HMA TAPER DETAIL

TYPICAL BUTT JOINT AND HMA TAPER  
FOR RESURFACING ONLY

\*\*\* PC CONCRETE, HMA OR HMA RESURFACED PAVEMENT.

NOTES

- A: MAINLINE ROADWAYS AND MAJOR SIDE ROADS.
  - B: MINOR SIDE ROADS.
  - C: THE TEMP. RAMP SHALL BE CONSTRUCTED IMMEDIATELY UPON REMOVAL OF THE EXISTING HMA SURFACE.
  - D: THE BUTT JOINT SHALL BE CONSTRUCTED IMMEDIATELY PRIOR TO PLACING THE PROPOSED HMA COURSES.
  - E: TAPER THE TEMP. RAMP AT A RATE OF 3'-0" (900 mm) PER 1 INCH (25 mm) OF MILLING THICKNESS.
  - F: INSTALLATION AND REMOVAL OF THE 4'-6" (1.35 m) TEMP. RAMP IS INCLUDED IN COST OF HMA SURFACE REMOVAL - BUTT JOINT
  - G: SEE ARTICLE 406.08 AND 406.14 OF THE STANDARD SPECIFICATIONS FOR "HMA AND/OR PCC SURFACE REMOVAL, BUTT JOINT".
- \* SEE TYPICAL SECTIONS FOR MILLING THICKNESS.
- \*\*\* 20'-0" (6.1 m) PER 1 (25) RESURFACING (NOTE "A")  
10'-0" (3.0 m) PER 1 (25) RESURFACING (NOTE "B")

BASIS OF PAYMENT:

THE BUTT JOINT WILL BE PAID FOR AT THE CONTRACT UNIT PRICE PER SQUARE YARD (SQUARE METER) FOR "HOT-MIX ASPHALT SURFACE REMOVAL - BUTT JOINT" OR FOR "PORTLAND CEMENT CONCRETE SURFACE REMOVAL - BUTT JOINT".

ALL DIMENSIONS ARE IN INCHES (MILLIMETERS) UNLESS OTHERWISE SHOWN.

FILE NAME =	USER NAME = equelff	DESIGNED - M. DE YONG	REVISED - R. SHAH 10-25-94
ca:\pwork\pwid01\AQUEELFF\8136528\01std.dgn		DRAWN -	REVISED - A. ABBAS 03-21-97
	PLOT SCALE = 50.0000' / IN.	CHECKED -	REVISED - M. GOMEZ 04-06-01
	PLOT DATE = 4/23/2009	DATE - 06-13-90	REVISED - R. BORO 01-01-07

STATE OF ILLINOIS  
DEPARTMENT OF TRANSPORTATION

BUTT JOINT AND  
HMA TAPER DETAILS

SCALE: NONE SHEET NO. 1 OF 1 SHEETS STA. TO STA.

F.A.I. RTE.	SECTION	COUNTY	TOTAL SHEETS	SHEET NO.
55	22-1AC-RS-2	DUPAGE	10	6
BD400-05 BD32			CONTRACT NO. 60H01	
FED. ROAD DIST. NO. 1 ILLINOIS FED. AID PROJECT				

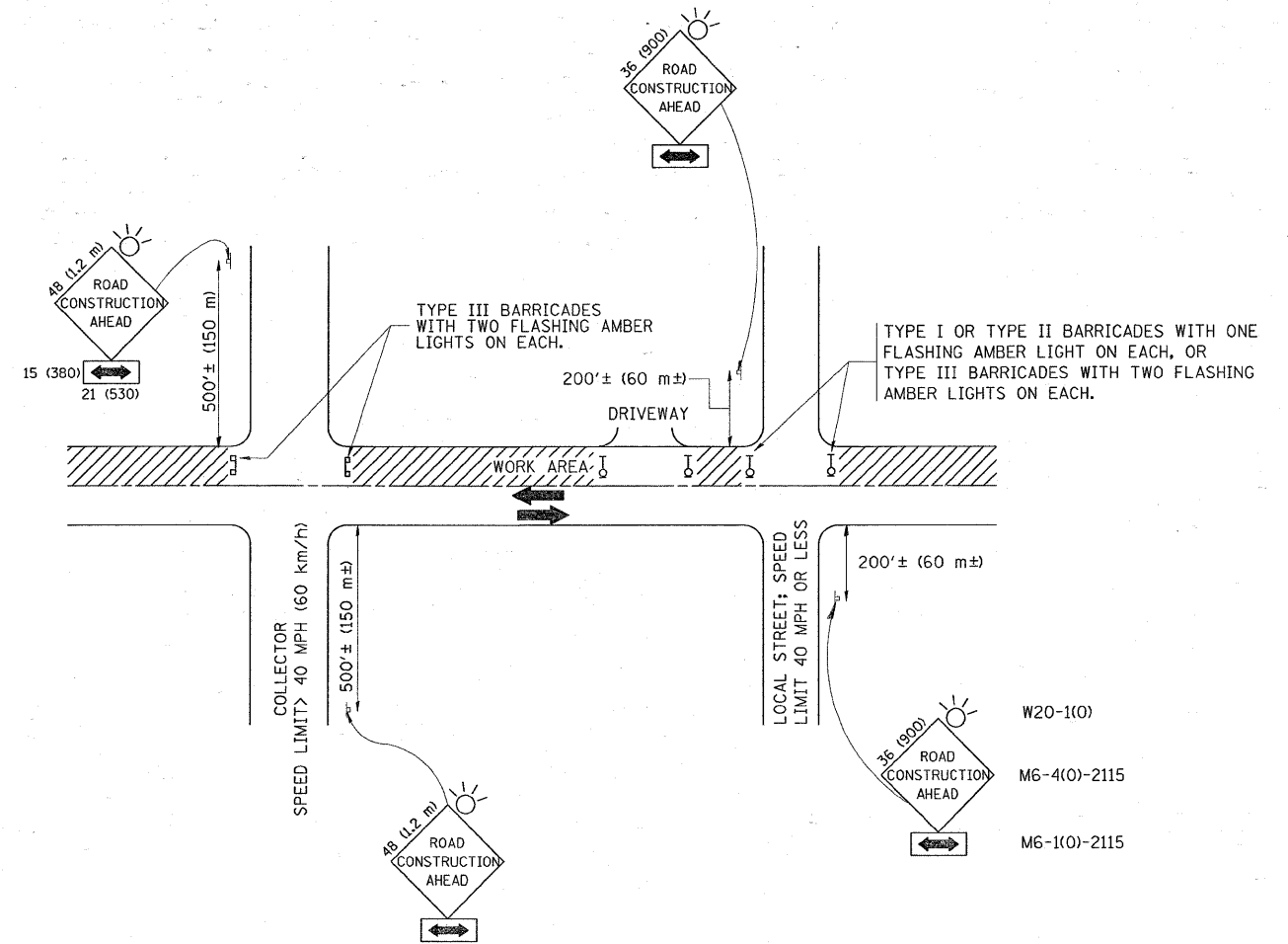

### TRAFFIC CONTROL AND PROTECTION FOR SIDE ROADS, INTERSECTIONS, AND DRIVEWAYS

#### NOTES:

##### A. FOR NO LANE RESTRICTION ON THE SIDE ROAD OR DRIVEWAYS

1. SIDE ROAD WITH A SPEED LIMIT OF 40 MPH (60 km/h) OR LESS AS SHOWN ON THE DRAWING AND AS DIRECTED BY THE ENGINEER:

a) ONE **ROAD CONSTRUCTION AHEAD** SIGN 36 x 36 (900x900) WITH A FLASHER AND FLAG MOUNTED ON IT APPROXIMATELY 200' (60 m) IN ADVANCE OF THE MAIN ROUTE.

b) THE CLOSED PORTION OF THE MAIN ROUTE SHALL BE PROTECTED BY BLOCKING WITH TYPE I, TYPE II OR TYPE III BARRICADES, 1/3 OF THE CROSS SECTION OF THE CLOSED PORTION.

2. SIDE ROAD WITH A SPEED LIMIT GREATER THAN 40 MPH (60 km/h) AS SHOWN ON THE DRAWING AND AS DIRECTED BY THE ENGINEER:

a) ONE **ROAD CONSTRUCTION AHEAD** SIGN 48 x 48 (1.2 m x 1.2 m) WITH A FLASHER MOUNTED ON IT APPROXIMATELY 500' (150 m) IN ADVANCE OF THE MAIN ROUTE.

b) THE CLOSED PORTION OF THE MAIN ROUTE SHALL BE PROTECTED BY BLOCKING WITH TYPE III BARRICADES, 1/2 OF THE CROSS SECTION OF THE CLOSED PORTION.

3. WHEN THE SIDE ROAD LIES BETWEEN THE BEGINNING OF THE MAINLINE SIGNING AND THE WORK ZONE, A SINGLE HEADED ARROW (M6-1) SHALL BE USED IN LIEU OF THE DOUBLE HEADED ARROW (M6-4).

##### B. FOR A LANE CLOSURE ON A SIDE ROAD OR DRIVEWAY:

USE APPLICABLE PORTIONS OF THE TYPICAL APPLICATION OF TRAFFIC CONTROL DEVICES (STD. 701501, STD. 701606 OR THE APPROPRIATE STANDARD). THE SPACING OF SIGNS AND BARRICADES SHALL BE ADJUSTED FOR FIELD CONDITIONS AS DIRECTED BY THE ENGINEER. THE DIRECTIONAL ARROW SHALL BE COVERED OR REMOVED WHEN NO LONGER CONSISTENT WITH THE SIDE ROAD LANE CLOSURE.

C. ADVANCE WARNING SIGNS ARE TO BE OMITTED ON DRIVEWAY UNLESS OTHERWISE NOTED.

D. THE TRAFFIC CONTROL AND PROTECTION FOR SIDE ROADS, INTERSECTIONS, AND DRIVEWAYS SHALL BE INCIDENTAL TO THE COST OF SPECIFIED TRAFFIC CONTROL STANDARDS OR ITEMS.

All dimensions are in millimeters (inches) unless otherwise shown.

FILE NAME =	USER NAME = aqueslfff	DESIGNED - LHA	REVISED - J. OBERLE 10-18-95
c:\pwork\pwork\001\AQUELFFF\0136528\0136528.dgn		DRAWN -	REVISED - A. HOUSEH 03-06-96
	PLOT SCALE = 50.0000 / IN.	CHECKED -	REVISED - A. HOUSEH 10-15-96
	PLOT DATE = 4/23/2009	DATE - 06-89	REVISED - T. RAMMACHER 01-06-00

STATE OF ILLINOIS  
DEPARTMENT OF TRANSPORTATION

TRAFFIC CONTROL AND PROTECTION FOR  
SIDE ROADS, INTERSECTIONS, AND DRIVEWAYS

SCALE: NONE SHEET NO. 1 OF 1 SHEETS STA. TO STA.

F.A.I. RTE.	SECTION	COUNTY	TOTAL SHEETS	SHEET NO.
55	22-1AC-RS-2	DUPAGE	10	7
TC-10			CONTRACT NO. 60H01	
FED. ROAD DIST. NO. 1 [ILLINOIS] FED. AID PROJECT				

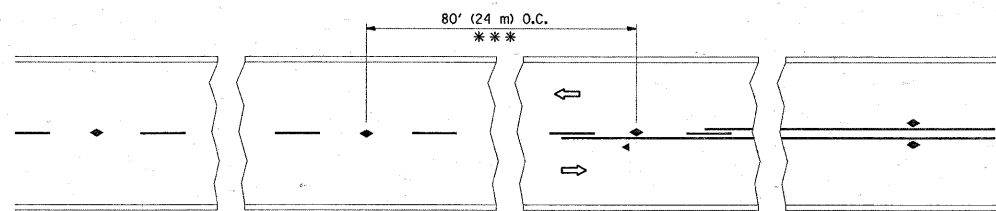

\*\*\* REDUCE TO 40' (12 m) O.C. ON CURVES WITH POSTED OR ADVISORY SPEED 45 M.P.H. (70 km/h) OR LESS.

TWO-LANE/TWO-WAY

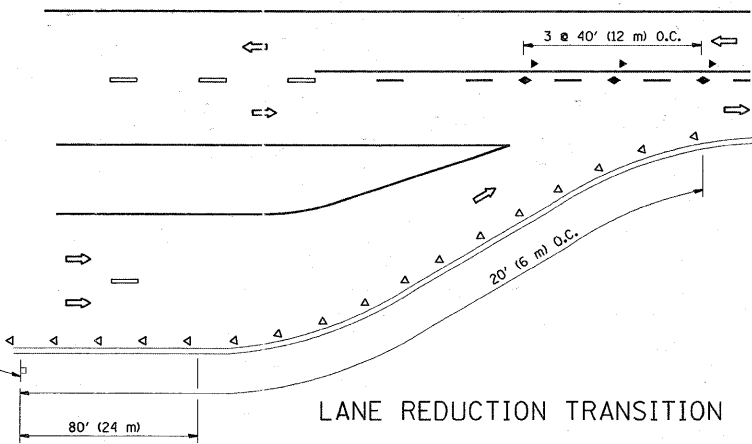

LANE REDUCTION TRANSITION

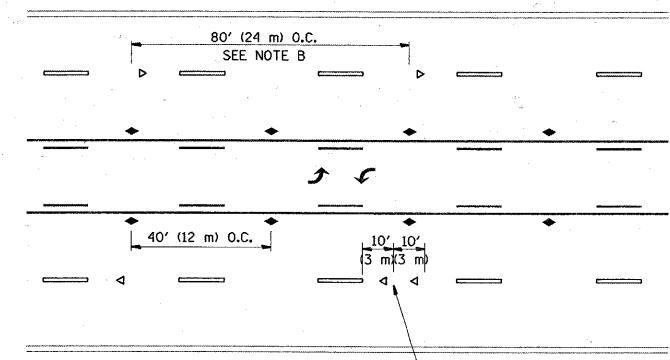

TWO-WAY LEFT TURN

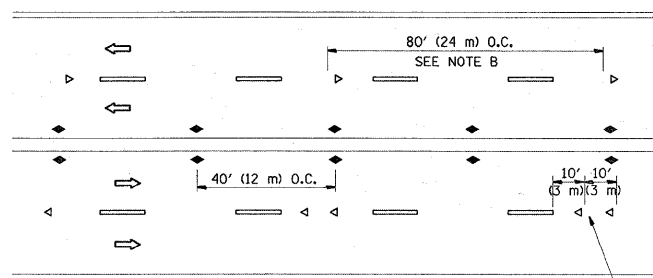

MULTI-LANE/UNDIVIDED

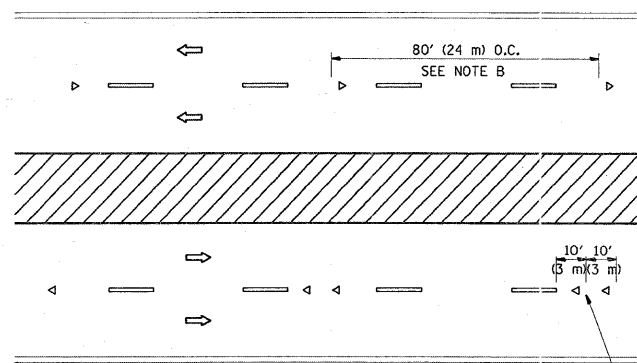

MULTI-LANE/DIVIDED

GENERAL NOTES

1. MARKERS USED WITH DASHED LINES SHALL BE CENTERED IN THE GAP BETWEEN SEGMENTS.
2. MARKERS USED ADJACENT TO SOLID LINES SHALL BE OFFSET 2 TO 3 (50 TO 75) TOWARD TRAFFIC AS SHOWN.
3. MARKERS THROUGH TANGENTS LESS THAN 500' (150 m) IN LENGTH BETWEEN CURVES SHALL BE INSTALLED AT THE LESSER OF THE TWO CURVE SPACINGS.

SYMBOLS

- YELLOW STRIPE
- WHITE STRIPE
- ◀ ONE-WAY AMBER MARKER
- ◁ ONE-WAY CRYSTAL MARKER (W/O)
- ◆ TWO-WAY AMBER MARKER

LANE MARKER NOTES

- B. REDUCE TO 40' (12 m) O.C. ON CURVES WHERE ADVISORY SPEEDS ARE 10 M.P.H (20 km/h) LOWER THAN POSTED SPEEDS.
- A. USE DOUBLE LANE LINE MARKERS SPACED AS SHOWN.

DESIGN NOTES

1. DOUBLE LANE LINE MARKERS SHALL BE USED UNLESS SPECIFIED OTHERWISE.
2. EXCEPT AS SHOWN ON THE LANE REDUCTION TRANSITION AND FREEWAY EXIT RAMP DETAIL, MARKERS ARE NOT TO BE SPECIFIED ON RIGHT EDGE LINES.
3. THE EXACT MARKER LIMITS, SPACING, AND COLOR SHOULD BE INCLUDED IN THE PLANS.
4. MARKERS SHOULD NOT BE USED ALONGSIDE CURBS EXCEPT FOR EXTREMELY SHORT SECTIONS OF CURBS WHERE NOT MORE THAN TWO MARKERS WOULD BE INVOLVED.

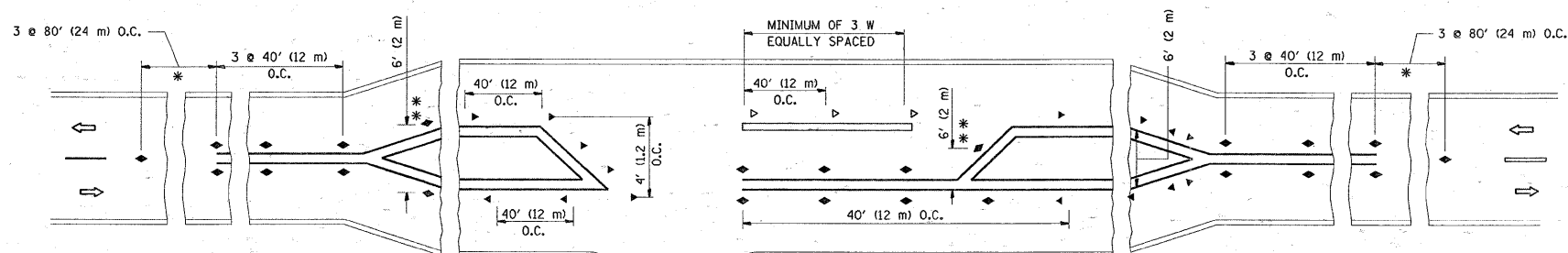

LEFT TURN

\* SEE TWO-LANE/TWO-WAY WHERE MARKERS CONTINUE  
 \*\* WHERE THE MEDIAN WIDTH IS 6' (2 m) OR LESS USE TWO-WAY MARKERS.

All dimensions are in inches (millimeters) unless otherwise shown.

FILE NAME =	USER NAME = aqueslff	DESIGNED -	REVISED - T. RAMMACHER 09-19-94	<b>STATE OF ILLINOIS DEPARTMENT OF TRANSPORTATION</b>	<b>TYPICAL APPLICATIONS RAISED REFLECTIVE PAVEMENT MARKERS (SNOW-PLOW RESISTANT)</b>			F.A.I. RTE.	SECTION	COUNTY	TOTAL SHEETS	SHEET NO.	
ca:\pw\work\PIWIDOT\AQUEELFF\d0136528\d0136528.dgn	PLOT SCALE = 50.0000' / IN.	DRAWN -	REVISED - T. RAMMACHER 03-12-99		SCALE: NONE	SHEET NO. 1 OF 1 SHEETS	STA.	TO STA.	55	22-1AC-RS-2	DUPAGE	10	8
PLOT DATE = 4/23/2009	DATE -	CHECKED -	REVISED - T. RAMMACHER 01-06-00					<b>TC-11</b>		CONTRACT NO. 60H01			
		DATE -	REVISED -					FED. ROAD DIST. NO. 1 ILLINOIS FED. AID PROJECT					



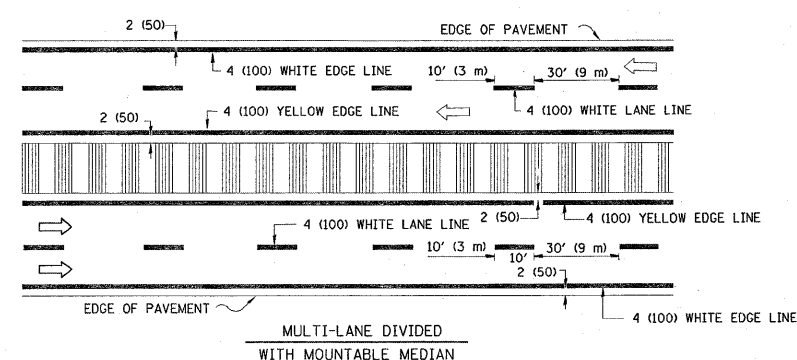
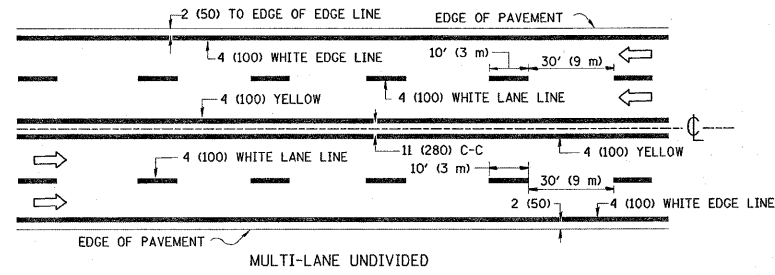
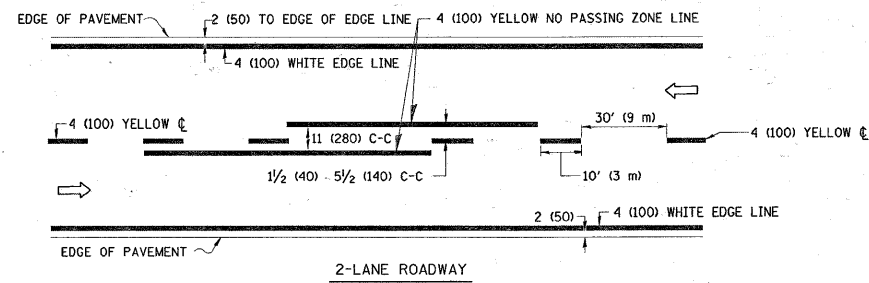

NOTE: MEDIANS WITH BARRIER CURB DO NOT REQUIRE AN EDGE LINE

**TYPICAL LANE AND EDGE LINE MARKING**

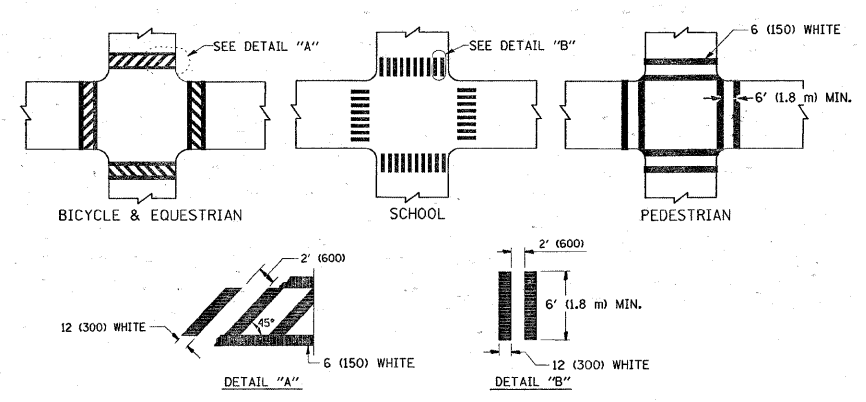

**TYPICAL CROSSWALK MARKING**

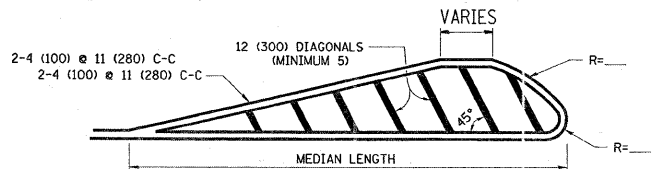
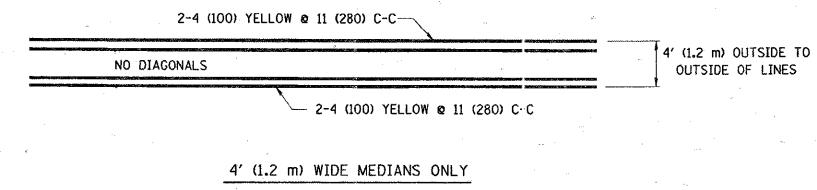

FOR MEDIAN LENGTHS WHERE DIAGONAL SPACING CANNOT BE ATTAINED, USE 5 (FIVE) EQUALLY SPACED DIAGONAL LINES.  
 DIAGONAL LINE SPACING: 50' (15 m) C-C (LESS THAN 30MPH (50 km/h))  
 75' (25 m) C-C 30MPH (50 km/h) TO 45MPH (70 km/h)  
 150' (45 m) C-C (MORE THAN 45MPH (70 km/h))

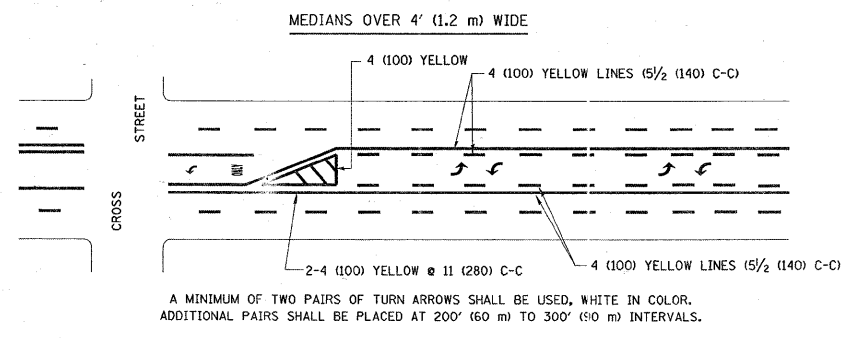

**TYPICAL PAINTED MEDIAN MARKING**

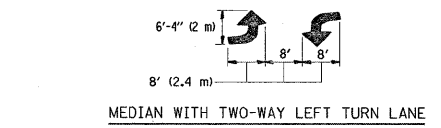

**TYPICAL LEFT (OR RIGHT) TURN LANE**

FULL SIZE LETTERS 8' (2.4 m) AND ARROWS SHALL BE USED.  
 AREA = 15.6 SQ. FT. (1.5 m<sup>2</sup>) ONLY AREA = 20.8 SQ. FT. (1.9 m<sup>2</sup>)  
 \* TURN LANES IN EXCESS OF 400' (120 m) IN LENGTH MAY HAVE AN ADDITIONAL SET OF ARROW - "ONLY" INSTALLED MIDWAY BETWEEN THE OTHER TWO SETS OF ARROW - "ONLY".

**TYPICAL TURN LANE MARKING**

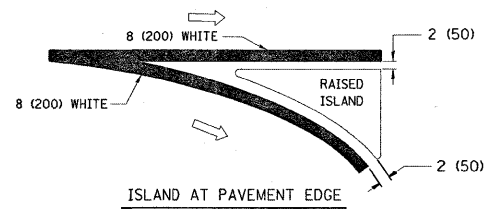
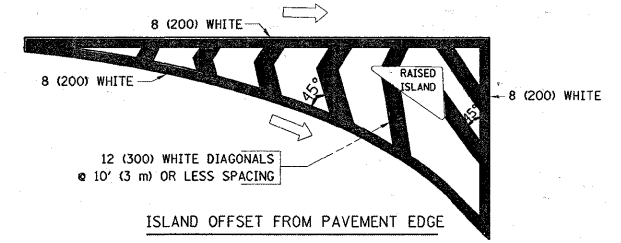

**TYPICAL ISLAND MARKING**

TYPE OF MARKING	WIDTH OF LINE	PATTERN	COLOR	SPACING / REMARKS
CENTERLINE ON 2 LANE PAVEMENT	4 (100)	SKIP-DASH	YELLOW	10' (3 m) LINE WITH 30' (9 m) SPACE
CENTERLINE ON MULTI-LANE UNDIVIDED PAVEMENT	2 @ 4 (100)	SOLID	YELLOW	11 (280) C-C
NO PASSING ZONE LINES: FOR ONE DIRECTION FOR BOTH DIRECTIONS	4 (100) 2 @ 4 (100)	SOLID SOLID	YELLOW YELLOW	5/2 (140) C-C FROM SKIP-DASH CENTERLINE 11 (280) C-C OMIT SKIP-DASH CENTERLINE BETWEEN
LANE LINES	4 (100) 5 (125) ON FREEWAYS	SKIP-DASH SKIP-DASH	WHITE WHITE	10' (3 m) LINE WITH 30' (9 m) SPACE
DOTTED LINES (EXTENSIONS OF CENTER, LANE OR TURN LANE MARKINGS)	SAME AS LINE BEING EXTENDED	SKIP-DASH	SAME AS LINE BEING EXTENDED	2' (600) LINE WITH 6' (1.8 m) SPACE
EDGE LINES	4 (100)	SOLID	YELLOW-LEFT WHITE-RIGHT	OUTLINE MOUNTABLE MEDIANS IN YELLOW; EDGE LINES ARE NOT USED NEXT TO BARRIER CURB
TURN LANE MARKINGS	6 (150) LINE; FULL SIZE LETTERS & SYMBOLS (8' (2.4m))	SOLID	WHITE	SEE TYPICAL TURN LANE MARKING DETAIL
TWO WAY LEFT TURN MARKING	2 @ 4 (100) EACH DIRECTION 8' (2.4m) LEFT ARROW	SKIP-DASH AND SOLID IN PAIRS	YELLOW WHITE	10' (3 m) LINE WITH 30' (9 m) SPACE FOR SKIP-DASH; 5/2 (140) C-C BETWEEN SOLID LINE AND SKIP-DASH LINE SEE TYPICAL TWO-WAY LEFT TURN MARKING DETAIL
CROSSWALK LINES (PEDESTRIAN) A. DIAGONALS (BIKE & EQUESTRIAN) B. LONGITUDINAL BARS (SCHOOL)	2 @ 6 (150) 12 (300) @ 45° 12 (300) @ 90°	SOLID SOLID SOLID	WHITE WHITE WHITE	NOT LESS THAN 6' (1.8 m) APART 2' (600) APART SEE TYPICAL CROSSWALK MARKING DETAILS.
STOP LINES	24 (600)	SOLID	WHITE	PLACE 4' (1.2 m) IN ADVANCE OF AND PARALLEL TO CROSSWALK, IF PRESENT. OTHERWISE, PLACE AT DESIRED STOPPING POINT. PARALLEL TO CROSSROAD CENTERLINE, WHERE POSSIBLE
PAINTED MEDIANS	2 @ 4 (100) WITH 12 (300) DIAGONALS @ 45° NO DIAGONALS USED FOR 4' (1.2 m) WIDE MEDIANS	SOLID	YELLOW: TWO WAY TRAFFIC WHITE: ONE WAY TRAFFIC	11 (280) C-C FOR THE DOUBLE LINE SEE TYPICAL PAINTED MEDIAN MARKING.
GORE MARKING AND CHANNELIZING LINES	8 (200) WITH 12 (300) DIAGONALS @ 45°	SOLID	WHITE	DIAGONALS: 15' (4.5 m) C-C (LESS THAN 30MPH (50 km/h)) 20' (6 m) C-C 30MPH (50 km/h) TO 45MPH (70 km/h) 30' (9 m) C-C (OVER 45MPH (70 km/h))
RAILROAD CROSSING	24 (600) TRANSVERSE LINES; "RR" IS 6' (1.8 m) LETTERS; 16 (400) LINE FOR "X"	SOLID	WHITE	SEE STATE STANDARD 780001 AREA OF: "R"=3.6 SQ. FT. (0.33 m <sup>2</sup> ) EACH "X"=54.0 SQ. FT. (5.0 m <sup>2</sup> )
SHOULDER DIAGONALS	12 (300) @ 45°	SOLID	WHITE - RIGHT YELLOW - LEFT	50' (15 m) C-C (LESS THAN 30MPH (50 km/h)) 75' (25 m) C-C (30 MPH (50 km/h) TO 45MPH (70 km/h)) 150' (45 m) C-C (OVER 45MPH (70 km/h))

FOR FURTHER DETAILS ON PAVEMENT MARKING REFER TO STANDARD SPECIFICATIONS FOR ROAD AND BRIDGE CONSTRUCTION AND STATE STANDARD 780001.

All dimensions are in inches (millimeters) unless otherwise shown.

FILE NAME =	USER NAME = aqueslff	DESIGNED - EVERS	REVISED - T. RAMMACHER 10-27-94
ca:\pw_work\VP1001\VAQUELFF\01136528\01136528.dgn		DRAWN -	REVISED - A. HOUSEH 10-09-96
	PLOT SCALE = 50.0000' / IN.	CHECKED -	REVISED - A. HOUSEH 10-17-96
	PLOT DATE = 4/23/2009	DATE - 03-19-90	REVISED - T. RAMMACHER 01-06-00

**STATE OF ILLINOIS  
DEPARTMENT OF TRANSPORTATION**

DISTRICT ONE		F.A.I. RTE.	SECTION	COUNTY	TOTAL SHEETS	SHEET NO.
TYPICAL PAVEMENT MARKINGS		55	22-1AC-RS-2	DUPAGE	10	9
SCALE: NONE		SHEET NO. 1 OF 1 SHEETS		STA. TO STA.	CONTRACT NO. 60H01	
FED. ROAD DIST. NO. 1 (ILLINOIS) FED. AID PROJECT						

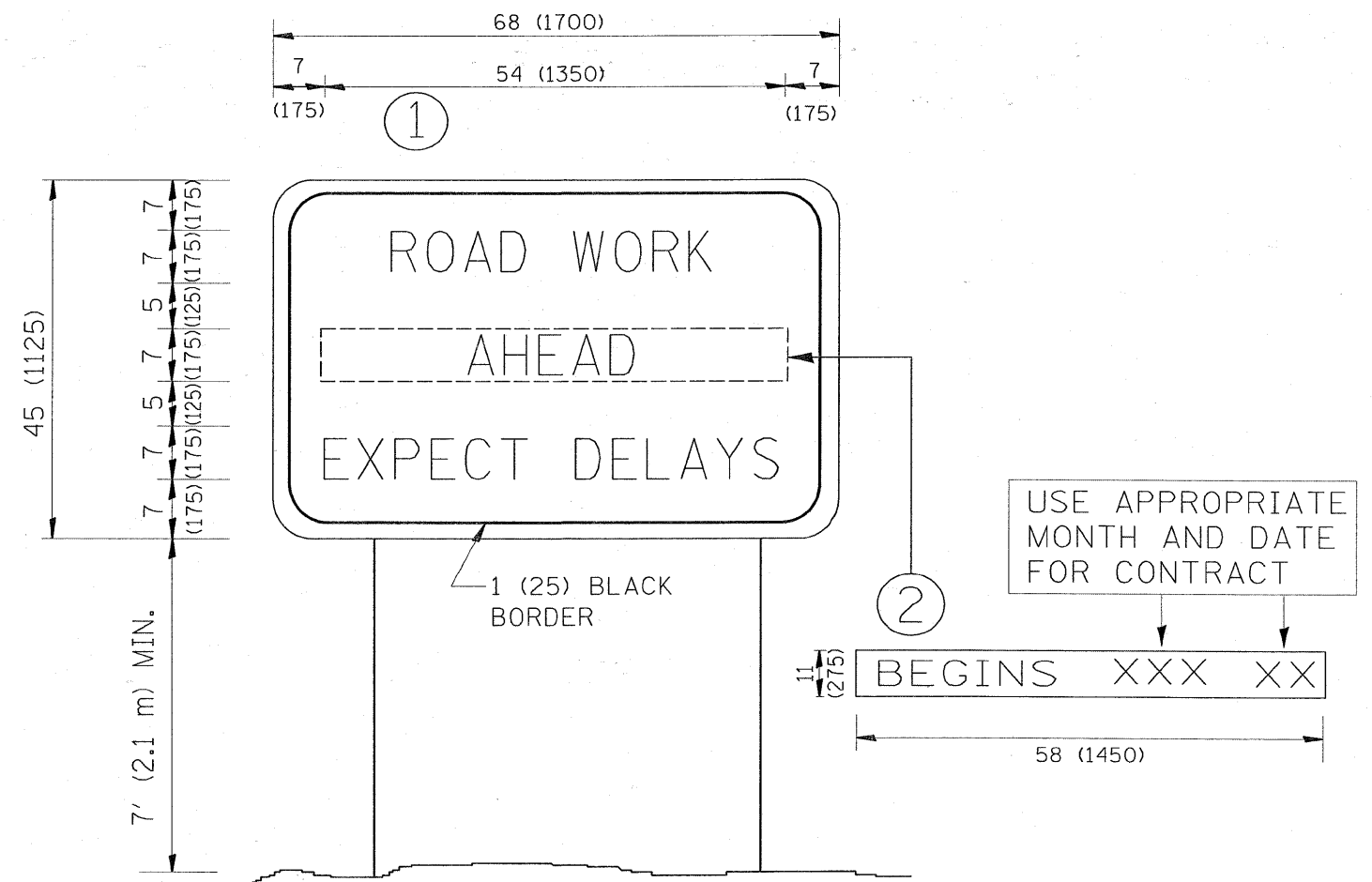

**NOTES:**

1. USE BLACK LETTERING ON ORANGE BACKGROUND.
2. ERECT SIGNS IN ADVANCE OF THE LOCATION FOR THE "ROAD CONSTRUCTION AHEAD" SIGN AT LOCATIONS AS DIRECTED BY THE ENGINEER.
3. ERECT SIGN ① WITH INSTALLED PANEL ② ONE WEEK PRIOR TO THE START OF CONSTRUCTION.
4. REMOVE PANEL ② SOON AFTER THE START OF CONSTRUCTION.
5. SEE SPECIAL PROVISION FOR "TEMPORARY INFORMATION SIGNING" FOR ADDITIONAL INFORMATION.
6. ONE SIGN ASSEMBLY EQUALS 25.70 SQ. FT. (2.3 SQ. M.)
7. SHALL BE PAID FOR AS TEMPORARY INFORMATION SIGNING.

ALL DIMENSIONS ARE IN INCHES (MILLIMETERS) UNLESS OTHERWISE SHOWN.

FILE NAME =	USER NAME = aqeelff	DESIGNED -	REVISED - R. MIRS 09-15-97	<b>STATE OF ILLINOIS DEPARTMENT OF TRANSPORTATION</b>	<b>ARTERIAL ROAD INFORMATION SIGN</b>			F.A.I. RTE.	SECTION	COUNTY	TOTAL SHEETS	SHEET NO.
os:\pwork\p\1001\AQUEELFF\0136528\0136528.dgn	DRAWN -	REVISED - R. MIRS 12-11-97	55					22-1AC-RS-2	DUPAGE	10	10	
PLOT SCALE = 50,0000 ' / IN.	CHECKED -	REVISED - T. RAMMACHER 02-02-99	<b>TC-22</b>			<b>CONTRACT NO. 60H01</b>						
PLOT DATE = 4/23/2009	DATE -	REVISED - C. JUCIUS 01-31-07	SCALE: NONE		SHEET NO. 1	OF 1 SHEETS	STA.	TO STA.	FED. ROAD DIST. NO. 1	ILLINOIS FED. AID PROJECT		