

EXISTING TYPICAL SECTION
STA. 54+24 TO 121+49

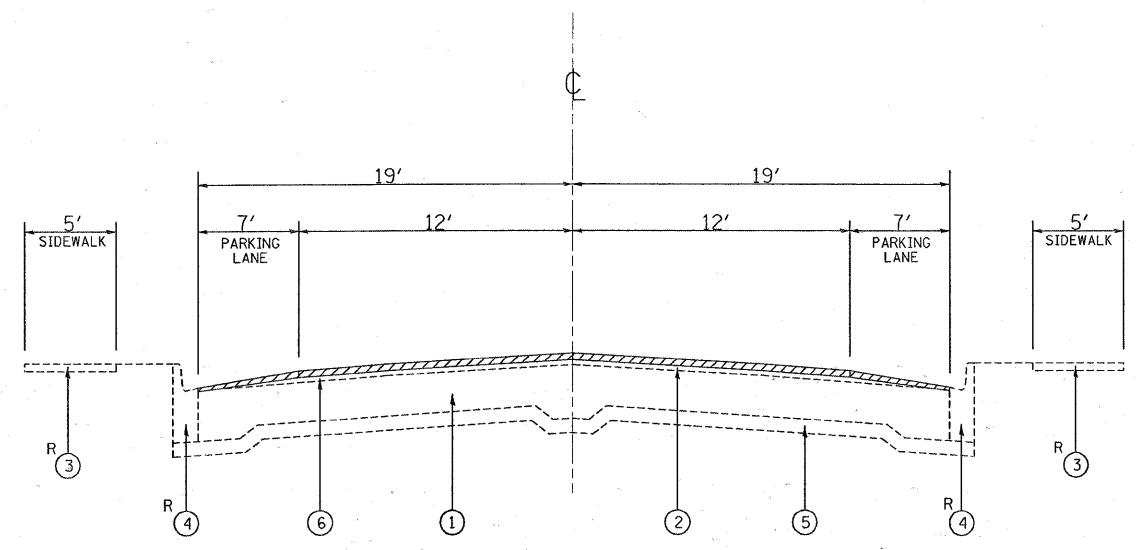

EXISTING TYPICAL SECTION
STA. 121+49 TO 160+20

LEGEND:

- ① EXISTING P.C.C. PAVEMENT, 9"
- ② EXISTING HOT-MIX ASPHALT SURFACE, 3"
- ③ EXISTING P.C.C. SIDEWALK, 5'
- ④ EXISTING COMBINATION CONCRETE CURB AND GUTTER, TYPE B-6.12
- ⑤ EXISTING STABILIZED SUB-BASE
- ⑥ PROPOSED HOT-MIX ASPHALT SURFACE REMOVAL, 2 1/4"
- ⑦ PROPOSED POLYMERIZED LEVELING BINDER (MACHINE METHOD), IL-4.75, N50, 3/4"
- ⑧ PROPOSED HOT-MIX ASPHALT SURFACE COURSE, MIX "D", N70, 1 1/2"
- R SIDEWALK AND CURB AND GUTTER REMOVAL AND REPLACEMENT
(LOCATION AS DIRECTED BY THE ENGINEER)

FILE NAME =	USER NAME = steedpa	DESIGNED -	REVISED -	STATE OF ILLINOIS DEPARTMENT OF TRANSPORTATION	EXISTING AND PROPOSED TYPICAL SECTIONS MORGAN ST.--79TH STREET TO 63RD STREET	O.R. RTE.	SECTION	COUNTY	TOTAL SHEETS	SHEET NO.
ct:\pw_work\pawdot\stedpa\d0137655\0145300-shr-plan.dgn	PLOT SCALE = 50.0000' / IN.	DRAWN -	REVISED -			0054	1922 RS-3	COOK	20	4
PLOT DATE = 4/16/2009	DATE -	CHECKED -	REVISED -			CONTRACT NO. 62042				
						ILLINOIS FED. AID PROJECT				
						SCALE:	SHEET NO. OF SHEETS	STA. TO STA.		