

# DETAIL OF INCIDENTAL RESURFACING

AT SIDE ROADS

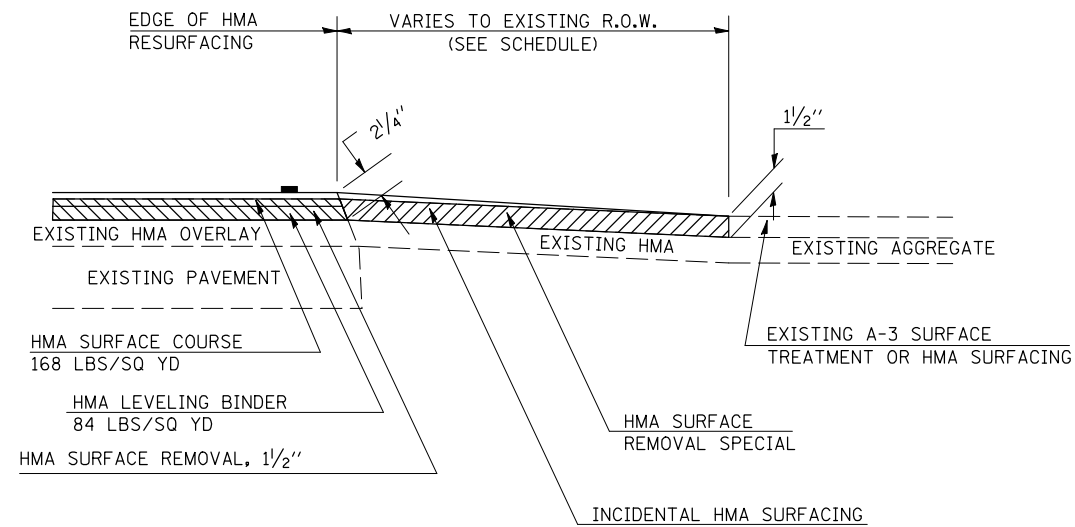

# RESURFACING TAPER DETAIL

BEGIN OF PROJECT - STA. 437+70.00  
 END OF PROJECT - STA. 1565+44.00  
 S.N. 057-0076 - STA. 1914+50.00 & 1919+60.00  
 S.N. 057-0077 - STA. 1646+98.35 & 1647+24.84  
 S.N. 057-0139 - STA. 1608+90.10 & 1609+09.64

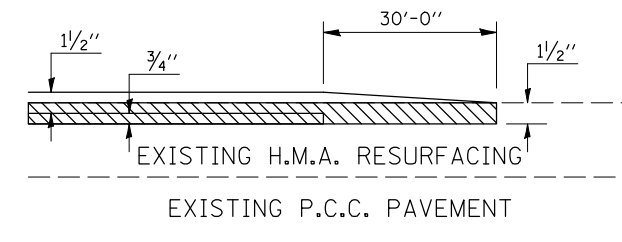

# DETAIL OF INCIDENTAL RESURFACING

AT ENTRANCES

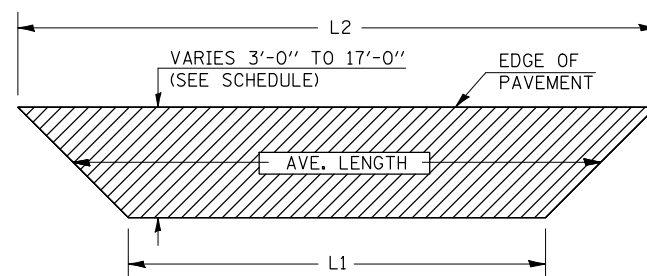
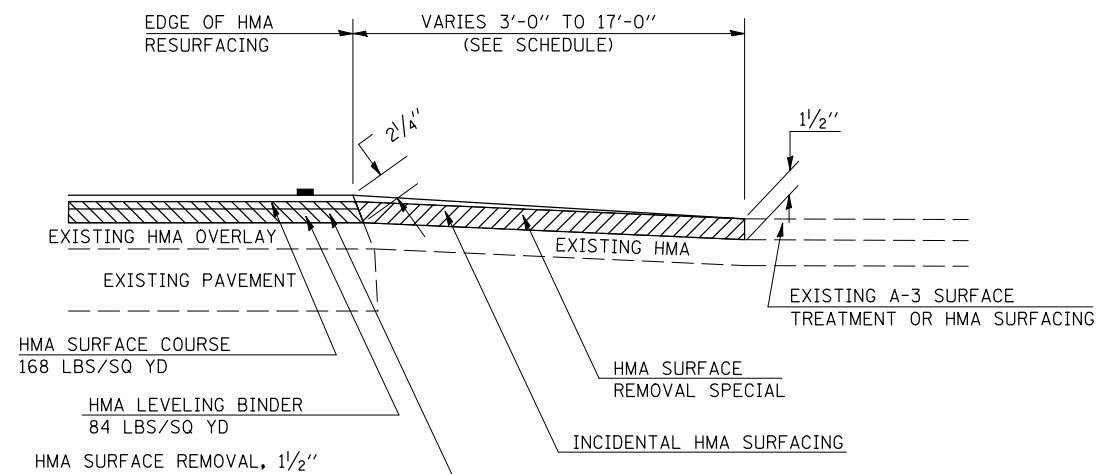

FILE NAME =	USER NAME = carrollt	DESIGNED -	REVISED -
ct:\pw\work\p\dot\carrollt\ad0104712\70509\Details.dgn		DRAWN -	REVISED -
		CHECKED -	REVISED -
		DATE -	REVISED -

**STATE OF ILLINOIS  
 DEPARTMENT OF TRANSPORTATION**

**RESURFACING DETAILS**

SCALE: SHEET NO. OF SHEETS STA. TO STA.

F.A.P. RTE.	SECTION	COUNTY	TOTAL SHEETS	SHEET NO.
693	(21,22)R,RS-1	MCLEAN	105	40
CONTRACT NO. 70509				
FED. ROAD DIST. NO. ILLINOIS FED. AID PROJECT				