

REVISIONS

NUMBER	BY	DATE

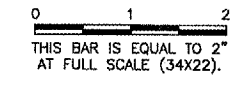

GREATER KANKAKEE AIRPORT  
 KANKAKEE, ILLINOIS  
 REHABILITATE AIRFIELD LIGHTING SYSTEM -  
 RUNWAY 16/34 AND TAXIWAY H  
 ELECTRICAL DETAILS - SHEET 1

© Copyright Carl, Inc.  
**CMT**  
 CRANFORD, MURPHY & TILLY, INC.  
 CONSULTING ENGINEERS  
 License No. 184-000618



DESIGN BY:	MND
DRAWN BY:	JRO
CHECKED BY:	MND
APPROVED BY:	
DATE:	02/29/08
JOB No:	07075-02

IL PROJECT: IKK-3743  
 A.I.P. PROJECT: 3-17-0057-B13

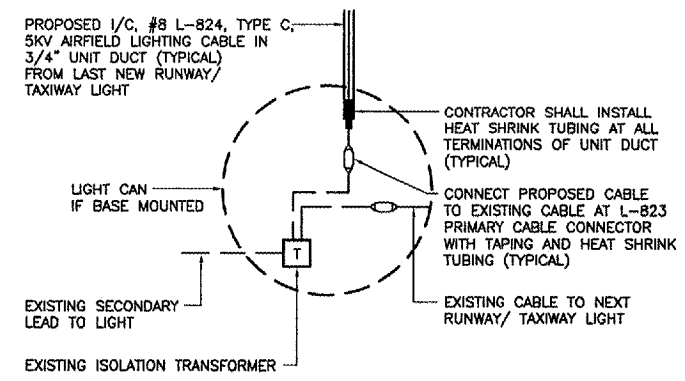

**RUNWAY/TAXIWAY LIGHTING CIRCUIT CONNECTION DETAIL**  
 NOT TO SCALE

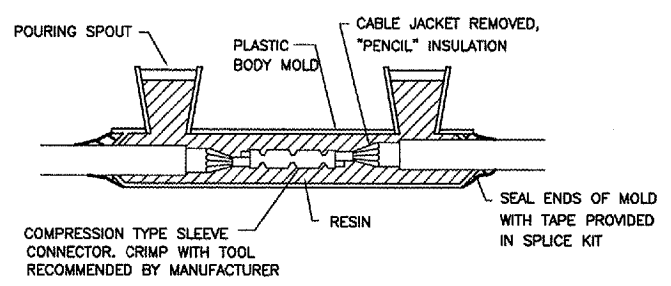

**TYPE A - CABLE SPLICE**

FOR SPLICES IN HOMERUNS AND FOR EXTENSIONS TO EXISTING CABLES ONLY  
 N.T.S.

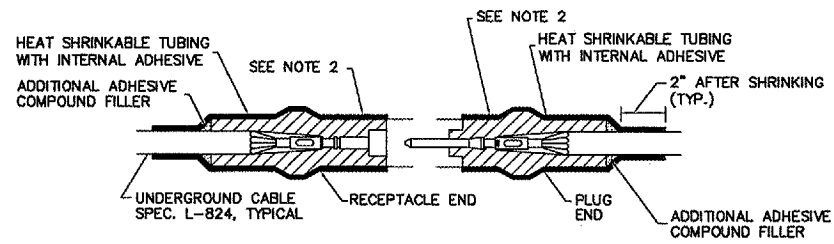

**TYPE B - CABLE SPLICE**

FOR SPLICES FOR USE AT JUNCTION OF HOMERUN WITH LOOP CIRCUIT  
 NOT TO SCALE

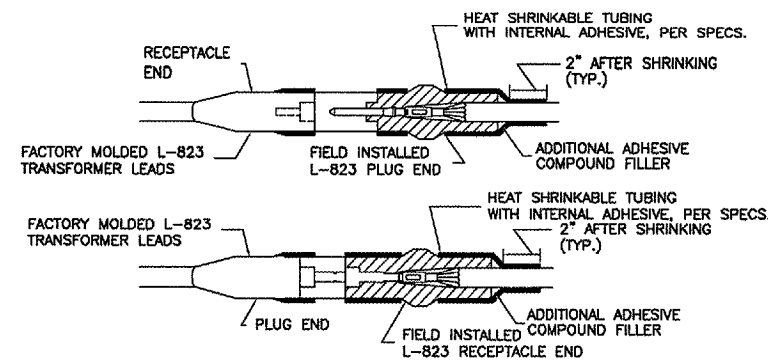

**TYPE C AND D - CABLE SPLICE**

FOR SPLICES AT RUNWAY/TAXIWAY LIGHTS AND SIGNS  
 NOT TO SCALE

**CABLE SPLICE NOTES**

- INSIDE DIAMETER OF CONNECTOR SHALL PROPERLY MATCH THE OUTSIDE DIAMETER OF CABLE.
- WRAP WITH AT LEAST ONE LAYER OF RUBBER OR SYNTHETIC RUBBER TAPE AND ONE LAYER OF PLASTIC TAPE, ONE-HALF LAPPED, EXTENDING AT LEAST 1-1/2 INCHES ON EACH SIDE OF JOINT.
- THE COST OF FURNISHING AND INSTALLING ALL SPLICE MATERIALS SHALL BE INCIDENTAL TO THE ASSOCIATED CABLE ITEMS.
- THE CONTRACTOR SHALL HAVE A MINIMUM OF FIVE (5) TYPE A SPLICE KITS ON THE JOB SITE AT ALL TIMES FOR EMERGENCY REPAIRS.

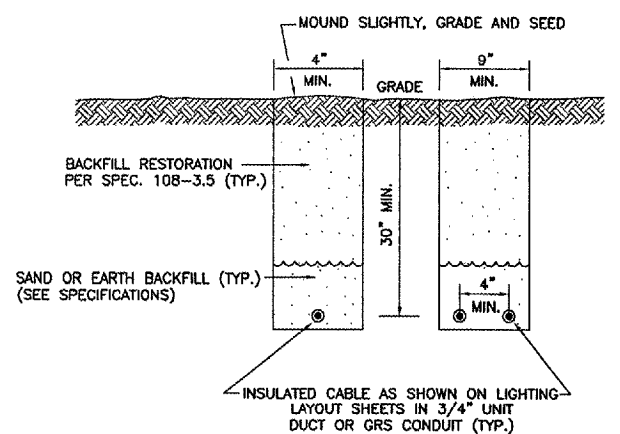

**TURF AREA CABLE TRENCH DETAIL**  
 NOT TO SCALE

**NOTES**

- TRENCHES WITH MORE THAN 2 CABLES SHALL BE INCREASED 4" IN WIDTH FOR EACH ADDITIONAL CABLE. IF SPECIFIED ON PLANS, TWO PARALLEL TRENCHES MAY BE CONSTRUCTED.
- DEPTH OF TRENCHES SHALL BE AS SHOWN UNLESS OTHERWISE SPECIFIED ON THE PLANS.
- SAND BACKFILL SHALL BE USED IF THE EXISTING SOIL DOES NOT MEET THE BACKFILL REQUIREMENTS.
- ALL DISTURBED SURFACES SHALL BE RESTORED TO THEIR ORIGINAL CONDITION. COST IS INCIDENTAL.

AT CONTRACTOR'S OPTION, CABLE PLOWING MAY BE USED IN LIEU OF TRENCHING.

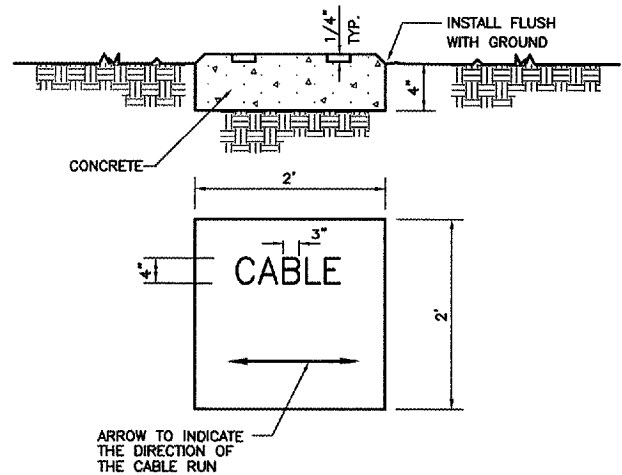

**TURF CABLE MARKER DETAIL**  
 NO SCALE

**NOTES**

- CABLE MARKERS SHALL BE INSTALLED AT ALL BENDS AND EVERY 200' ALONG THE CABLE RUN.
- ITEM 610 CONCRETE SHALL BE USED.
- ALL EXPOSED EDGES SHALL BE EDGED WITH A 1/4" RADIUS TOOL.
- THE COST OF FURNISHING AND INSTALLING NEW MARKERS SHALL BE INCIDENTAL TO THE ASSOCIATED CABLE ITEMS.
- 0.049 CU. YD. CONCRETE PER MARKER.
- CONTRACTOR SHALL LOCATE EXISTING CABLE MARKERS IN THE FIELD BEFORE WORK BEGINS IN ORDER TO RELOCATE CABLE MARKERS AT CORRECT LOCATIONS (COST INCIDENTAL TO CONTRACT).

**GENERAL NOTES:**

- THE CONCRETE BASE FOR BASE MOUNTED LIGHTS SHALL BE TROWEL FINISHED WITH A 45° BEVELED EDGE. SLOPE TO DRAIN (610).
- TRANSFORMER HOLDER SHALL BE ANY COMMERCIALY AVAILABLE BRICK.
- BREAKING GROOVE COUPLINGS SHALL NOT BE OVER 1" ABOVE GROUND LINE.
- ISOLATION TRANSFORMERS COME WITH A FACTORY INSTALLED PLUG (TYPE 1, CLASS A, STYLE 2) AND RECEPTACLE (TYPE 1, CLASS A, STYLE 9). A TYPE 1, CLASS B, STYLE 3 PLUG AND TYPE 1, CLASS B, STYLE 10 RECEPTACLE SHALL BE INSTALLED ON THE 1/C, No. 8, 5000 V., L-824 TYPE C CABLES FOR CONNECTION TO EACH TRANSFORMER.
- TO FURTHER REDUCE THE POSSIBILITY OF WATER/MOISTURE ENTRANCE INTO THE CONNECTOR BETWEEN THE CABLE AND THE FIELD ATTACHED CONNECTOR, IT IS REQUIRED THAT A HEAT SHRINKABLE TUBING WITH INTERNAL ADHESIVE BE APPLIED OVER THE ENTIRE CABLE CONNECTOR.
- ALL SIGNS, LIGHTS, CABLES AND TRANSFORMERS TO BE REMOVED SHALL REMAIN THE PROPERTY OF THE AIRPORT. AT THE DISCRETION OF THE AIRPORT MANAGER, THE CONTRACTOR MAY BE REQUIRED TO DISPOSE OF THESE MATERIALS OFFSITE AT NO ADDITIONAL COST.
- TAXIWAY LIGHTS SHALL HAVE A BLUE LENS, RUNWAY LIGHTS SHALL HAVE A CLEAR OR 180° AMBER/CLEAR LENS AS DESIGNATED ON PLANS.
- DUCT MARKERS SHALL BE INSTALLED AT EVERY NEW DUCT AND AT EVERY EXISTING DUCT USED FOR THIS PROJECT.
- CONTRACTOR SHALL HAVE THE OPTION TO TRENCH OR PLOW UNIT DUCT. NO ADDITIONAL PAYMENT SHALL BE MADE FOR TRENCHING.
- INSTALL 1/C #6 AWG BARE COPPER GROUND JUMPER CONNECTED TO GROUND LUG INSIDE BASE CAN OR STAKE AND EXOTHERMICALLY WELDED TO GROUND ROD. INSTALL GROUND LUG FOR EXISTING CANS AND STAKES, IF REQUIRED. INSTALLING GROUND LUGS FOR EXISTING CANS AND STAKES SHALL BE AT NO ADDITIONAL COST.

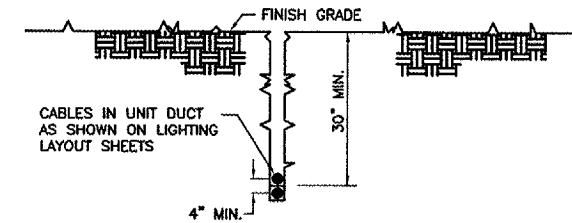

**CABLE IN UNIT DUCT - PLOWED**  
 NOT TO SCALE

NOTE: CONTRACTOR SHALL HAVE THE OPTION TO TRENCH OR PLOW UNIT DUCT. NO ADDITIONAL PAYMENT SHALL BE MADE FOR TRENCHING.

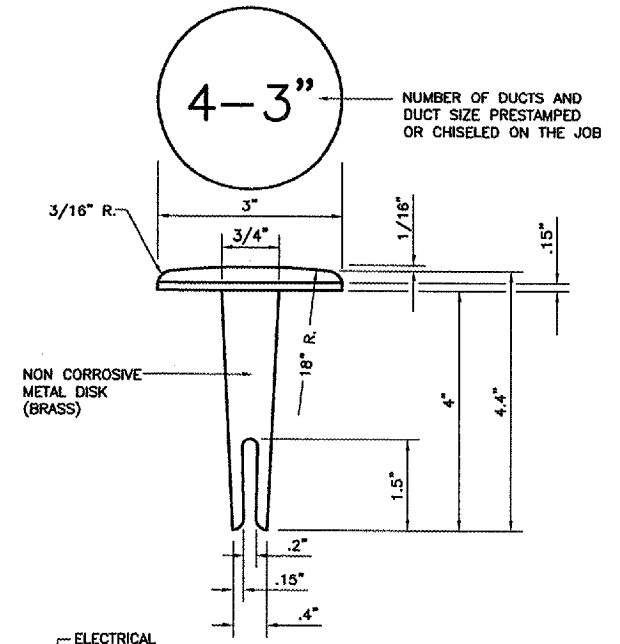

**DUCT MARKER DETAIL**  
 NOT TO SCALE

NEW DUCT MARKERS SHALL BE INSTALLED AT ALL EXISTING AND NEW DUCT LOCATIONS USED IN THE PROJECT (COST INCIDENTAL).

DUCT MARKERS SHALL BE DRILLED AND GROUTED SO THEY ARE RECESSED FROM THE SURFACE OF THE PAVEMENTS.