

REVISIONS		
NUMBER	BY	DATE

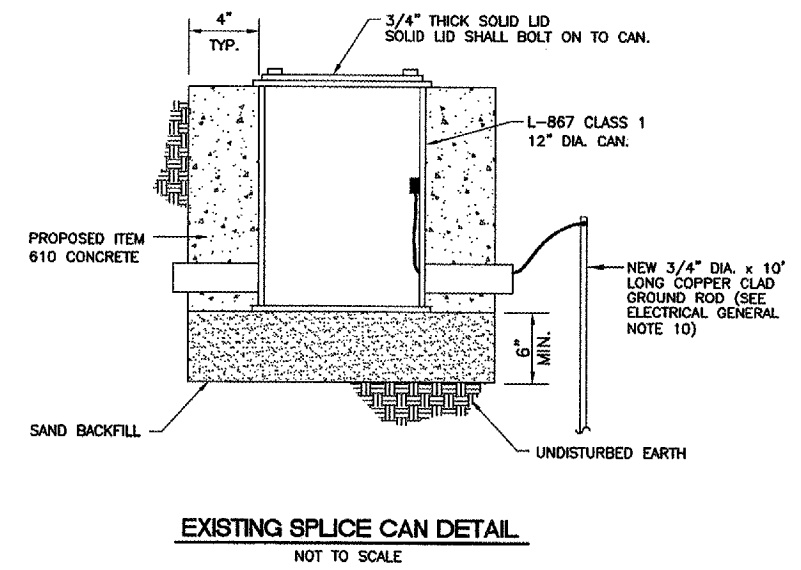
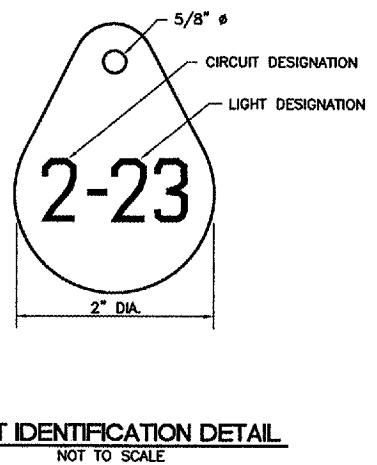
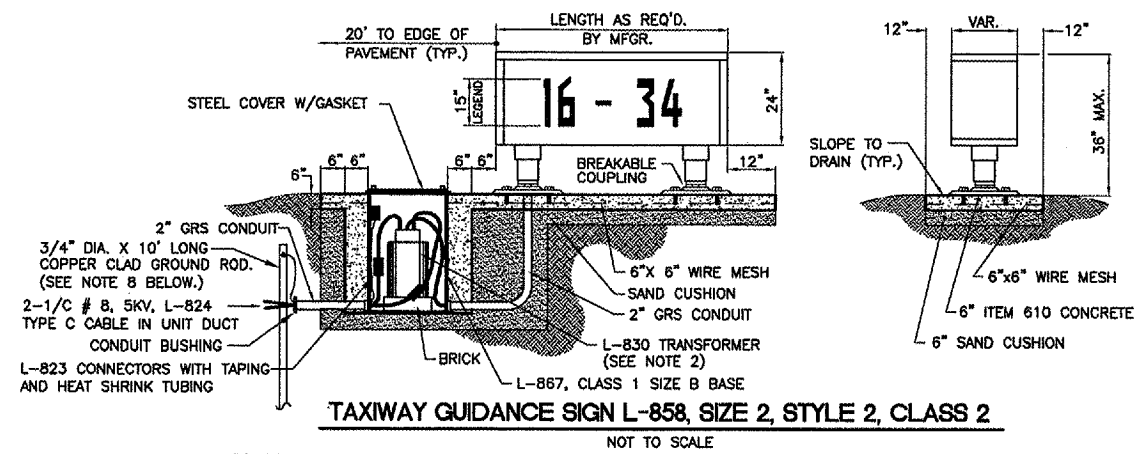
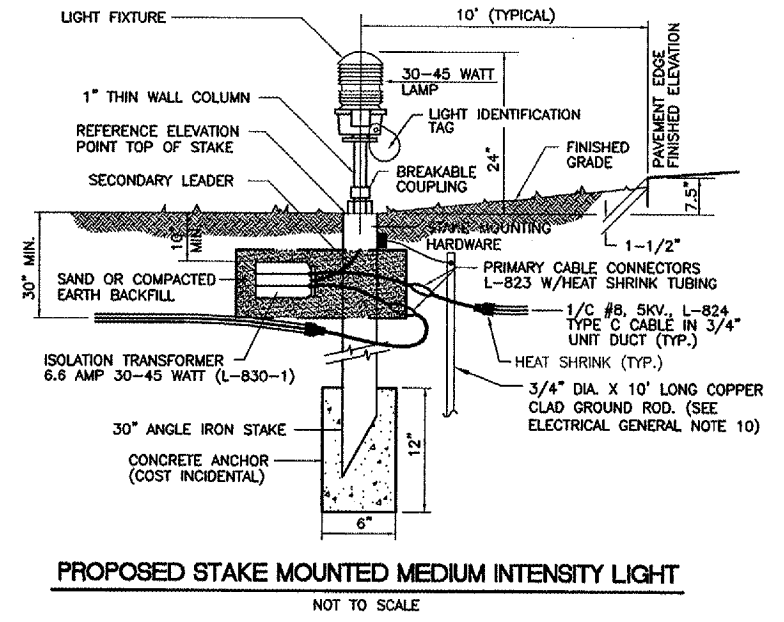
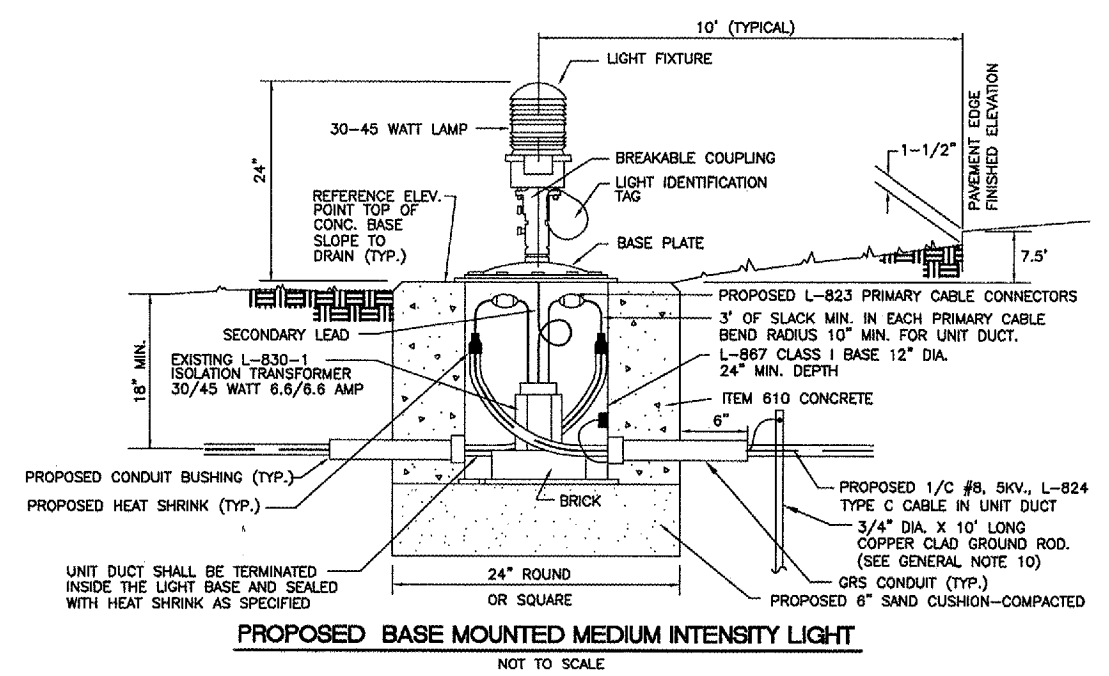
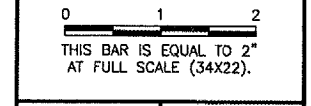

SIGNAGE NOTES

1. ALL SIGNS ARE LUMACURVE 2-SIDED SIGNS BY STANDARD SIGNS OR APPROVED EQUAL.
2. TRANSFORMER WATTAGE AS RECOMMENDED BY MANUFACTURER.
3. LIGHTED SIGNS SHALL BE BASE MOUNTED ONLY.
4. UNIT DUCT SHALL BE TERMINATED IN THE CAN AND SEALED TO THE CABLE WITH HEAT SHRINK AS SPECIFIED.
5. THE NUMBER OF MODULES PER SIGN SHALL BE AS RECOMMENDED BY THE MANUFACTURER.
6. CONTRACTOR SHALL SUBMIT DETAILED SHOP DRAWING INCLUDING SIGN, COLOR, SIZE AND PROPOSED LEGEND, IN ENOUGH DETAIL AND DETERMINE PROPOSED SPACING AND OTHER INFORMATION REQUIRED BY SPECIAL PROVISIONS. CONTRACTOR TO VERIFY PROPOSED SIGN LOCATIONS AND ORIENTATIONS WITH RESIDENT ENGINEER PRIOR TO INSTALLATION.
7. INSTALL 1/C #8 AWG BARE COPPER GROUND JUMPER CONNECTED TO GROUND LUG INSIDE BASE CAN AND EXOTHERMICALLY WELDED TO GROUND ROD. INSTALL GROUND LUG FOR EXISTING CANS, IF REQUIRED.

NOTES:

1. INSTALL A NONCORROSIVE DISC OF 2" MINIMUM DIAMETER WITH THE NUMBER PERMANENTLY STAMPED, CUT OUT, OR ENGRAVED UNDER THE HEAD OF THE BASE PLATE BOLT OR ATTACHED TO LIGHT FLANGE WITH A SET SCREW.
2. NUMERALS SHOWN ARE FOR ILLUSTRATIVE PURPOSES ONLY. ALL EXISTING AND PROPOSED TAXIWAY AND RUNWAY LIGHTS SHALL BE TAGGED AS DIRECTED BY THE RESIDENT ENGINEER. ALL LIGHTS ON EXISTING CIRCUITS THAT HAVE LIGHTING IMPROVEMENTS (PROPOSED OR RELOCATED LIGHTS) SHALL BE RETAGGED.
3. COST OF TAGGING LIGHTS SHALL NOT BE PAID FOR SEPARATELY BUT SHALL BE CONSIDERED INCIDENTAL TO THE CONTRACT.

**GREATER KANKAKEE AIRPORT
 KANKAKEE, ILLINOIS
 REHABILITATE AIRFIELD LIGHTING SYSTEM -
 RUNWAY 16/34 AND TAXIWAY H**

ELECTRICAL DETAILS - SHEET 2

© copyright GMT, Inc.
GMT
 CRAWFORD, MURPHY & TILLY, INC.
 CONSULTING ENGINEERS
 License No. 84-000618

DESIGN BY:	MND
DRAWN BY:	JRO
CHECKED BY:	MND
APPROVED BY:	
DATE:	02/29/08
JOB No:	07075-02
IL PROJECT:	IKK-3743
A.I.P. PROJECT:	3-17-0057-B13