

NEENAH R-3493-A OR EQUAL EXTRA  
HEAVY DUTY FRAME AND LID. APPROX.  
WEIGHT 440 POUNDS.

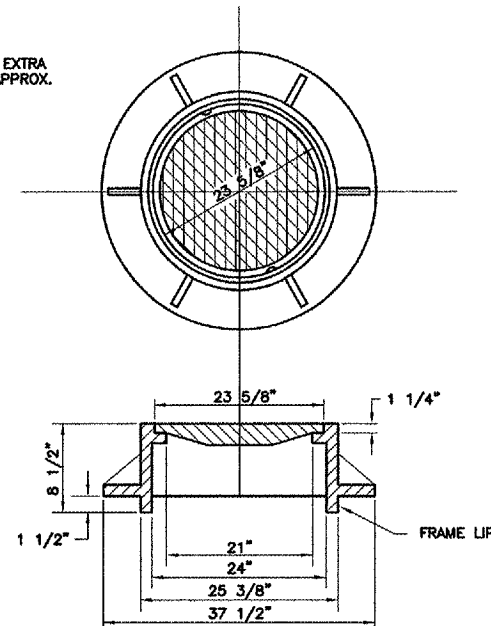

- NOTES:
1. USE FOR ALL MANHOLES (UNLESS NOTED OTHERWISE ON THE PLAN SHEETS).
  2. REMOVE BOLTS THAT HOLD THE GRATE TO THE FRAME AND DO NOT REINSTALL.

MANHOLE FRAME AND LID

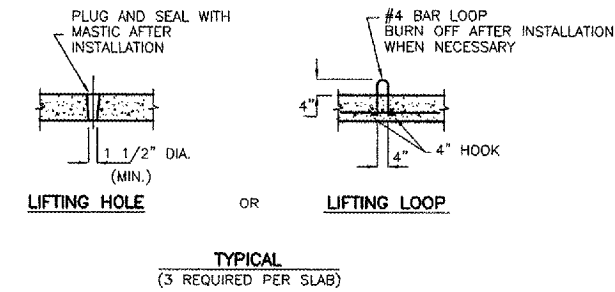
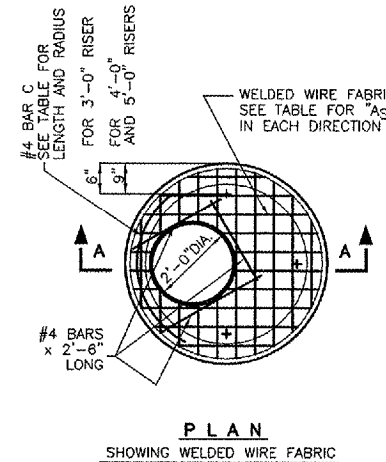

D	T	D <sub>0</sub> (MIN)	f	REINFORCEMENT	
				"A" S" W.W.F. EACH DIRECTION	#4 BAR C LENGTH RADIUS
3'-0"	See Standards 1514, 1526, 1527, and 1885	D + 2"	6"	.20 sq.in./lin.ft.	#4 4'-0" 1'-7"
4'-0"			6"	.35 sq.in./lin.ft.	#5 4'-6" 2'-2"
5'-0"			8"	.35 sq.in./lin.ft.	#5 5'-0" 2'-8"

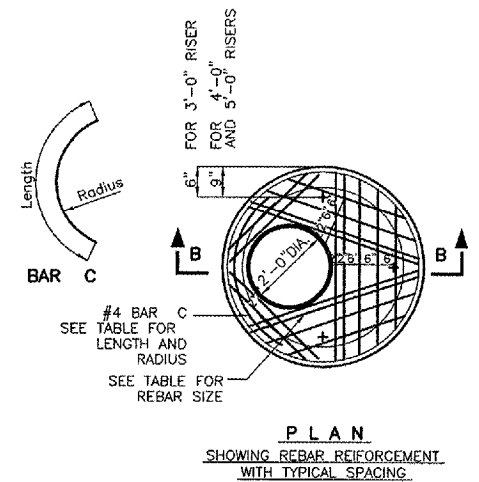

ALT. MATERIAL FOR WALLS	D	C	T
PRECAST REINFORCED CONCRETE RINGS	4'	2'-6"	5"
	5'	3'-0"	6"
MONOLITHIC CONCRETE	4'	2'-6"	6"
	5'	3'-0"	8"

FOR 6" DIAMETER MANHOLES, SEE IDOT STANDARD 602406. MANHOLE FRAME LIP NOTCH OUT DETAIL AND ADDITIONAL BEDDING REQUIREMENTS THAT ARE SHOWN ON THIS SHEET SHALL BE APPLIED TO IDOT STANDARD 602406.

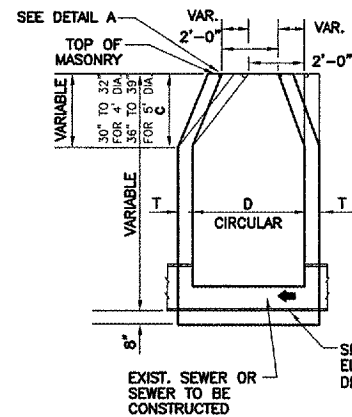

- NOTES:
- PRECAST REINFORCED CONCRETE RINGS AND MANHOLE FRAMES SHALL BE LAID IN FULL MOTAR BEDS WITH FLUSH JOINTS.
  - MOTAR MIX SHALL CONSIST OF 1 PART PORTLAND CEMENT & 3 PARTS SAND.
  - ALL CONCRETE SHALL HAVE A MIN. STRENGTH AT 28 DAYS OF 3500 P.S.I.
  - THE CONTRACT UNIT PRICE FOR MANHOLE SHALL INCLUDE INSTALLATION OF THE FRAME AND LID.

SEE PLAN SHEETS FOR ELEVATION OF INVERT AND DIAMETER OF SEWER

BOTTOM TO BE EITHER PLAIN CONCRETE OR PRECAST REINFORCED CONCRETE SLAB IDOT CA-14 OR -16

FURNISHING AND INSTALLING SAND CUSHION, FRAME, AND LID TO BE INCLUDED IN THE CONTRACT UNIT PRICE

NOTE:  
THE CONE OF THE MANHOLE SHALL BE CONSTRUCTED AS SHOWN BY THE DOTTED LINES ONLY WHEN THERE IS INTERFERENCE WITH UNDERGROUND CONDITIONS AND THESE CONDITIONS CAN NOT BE ALTERED.

DETAIL OF STORM MANHOLE  
ITEMS AR751540, AR751550, & AR751560

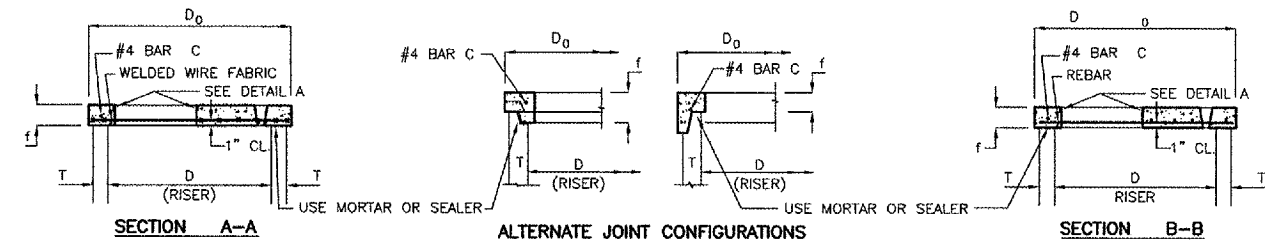

PRECAST REINFORCED CONCRETE  
FLAT SLAB TOP  
FOR MANHOLES, CATCH BASINS  
AND VALVE VAULTS

MODIFIED I.D.O.T.  
STANDARD 602601

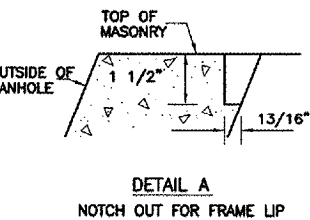

NOTES:

1. PRECAST FLAT SLAB TOPS SHALL CONFORM TO SECTION 602 OF THE STANDARD SPECIFICATIONS FOR ROAD AND BRIDGE CONSTRUCTION.
2. REINFORCEMENT BARS OR WELDED WIRE FABRIC SHALL BE IN ACCORDANCE WITH ARTICLE 1006.04 OF THE STANDARD SPECIFICATIONS FOR ROAD AND BRIDGE CONSTRUCTION.
3. JOINT CONFIGURATION AND DIMENSIONS SHALL MATCH AND FIT THE RISER JOINT DETAIL.
4. LIFTING DEVICES OTHER THAN SHOWN MAY BE USED SUBJECT TO APPROVAL BY THE ENGINEER.
5. THE FLAT SLAB TOP MAY BE USED IN LIEU OF THE TAPERED TOPS SHOWN ON STANDARDS 602001, 602011, 602306, 602401, OR 602501 AT THE OPTION OF THE CONTRACTOR OR WHEN FIELD CONDITIONS PROHIBIT THE USE OF TAPERED TOPS.
6. THE COST OF FURNISHING AND INSTALLING THE FLAT SLAB TOP SHALL BE INCLUDED IN THE UNIT PRICE FOR CATCH BASINS, MANHOLES, OR VALVE VAULTS.

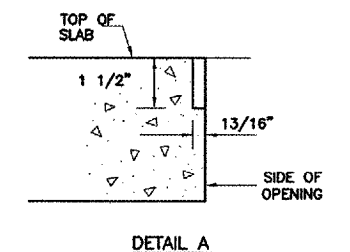

FOR 6" DIAMETER MANHOLES, SEE IDOT STANDARD 602406. MANHOLE FRAME LIP NOTCH OUT DETAIL AND ADDITIONAL BEDDING REQUIREMENTS THAT ARE SHOWN ON THIS SHEET SHALL BE APPLIED TO IDOT STANDARD 602406.