

SPECIAL USE SIGNS

1

RELOCATE SIGN PANEL ASSEMBLY - TYPE B I1-I107a "CABOT MICROELECTRONICS"

2

RELOCATE SIGN PANEL ASSEMBLY - TYPE B SPECIAL-INFORMATIONAL-4248

3

RELOCATE SIGN PANEL ASSEMBLY - TYPE B I1-I107g "5 STAR WINDOW"

4

RELOCATE SIGN PANELS TO NEW POLE SPECIAL-METRA(B)-3036 M6-1(B)-2115

4A

RELOCATE SIGN PANELS TO NEW POLE SPECIAL-METRA(B)-3036 M6-1(B)-2115

5

RELOCATE SIGN PANEL ASSEMBLY - TYPE A SPECIAL-IL-EMISSIONS(RT)-2436

5A

RELOCATE SIGN PANEL TO NEW POLE SPECIAL-IL-EMISSIONS(LT)-2436

6

RELOCATE SIGN PANEL TO NEAREST PROPOSED LIGHT POLE SPECIAL-NAPERVILLE-3054

7 NOT USED

8

RELOCATE SIGN PANEL ASSEMBLY - TYPE A SPECIAL-NEIGHBORHOOD-24

9

RELOCATE SIGN PANEL ASSEMBLY - TYPE B SPECIAL-CITY OF NAPERVILLE

10 NOT USED

11 NOT USED

12 NOT USED

13 NOT USED

14

RELOCATE SIGN PANEL ASSEMBLY - TYPE B SPECIAL-AURORA-3630 SPECIAL-POPULATION-3612

15

RELOCATE SIGN PANEL ASSEMBLY - TYPE A SPECIAL-AURORA ADOPT-1824 SPECIAL-GROUP PLAQUE-1812

16

SPECIAL-CITIES-3630 TO REMAIN

17

SPECIAL-PACE 530-18 TO REMAIN

18

RELOCATE SIGN PANEL SPECIAL-AURORA DOWNTOWN-24

19

RELOCATE SIGN PANEL SPECIAL-AURORA STORM-20

20

RELOCATE SIGN PANEL SPECIAL-AURORA TAILGATE-1824

MOUNT PEDESTRIAN PUSH BUTTON SIGN (R10-3e-915, LEGEND 10R/10L) DIRECTLY ABOVE PEDESTRIAN PUSH BUTTON WITH ARROW PARALLEL TO THE CROSSWALK FOR WHICH IT IS INTENDED

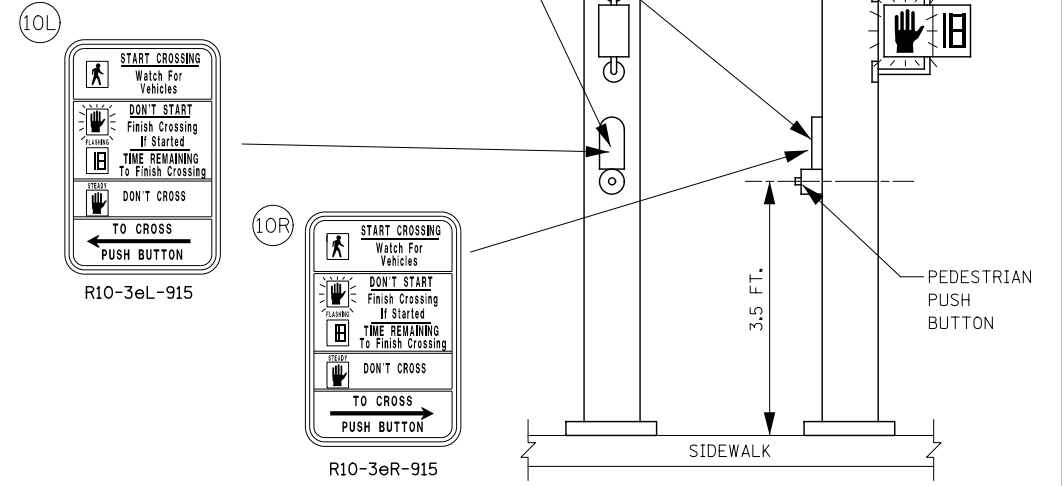

PEDESTRIAN PUSH BUTTON SIGN MOUNT DETAIL  
NOT TO SCALE

DESIGNED	PJO	REVISED	-
DRAWN	KES	REVISED	-
CHECKED	JCM	REVISED	-
DATE	12/14/2012	REVISED	-

STATE OF ILLINOIS  
DEPARTMENT OF TRANSPORTATION

SIGNING LEGEND  
SPECIAL USE SIGNS

SCALE: NONE SHEET NO. 21 OF 21 SHEETS STA. TO STA.

F.A.P. RTE.	SECTION	COUNTY	TOTAL SHEETS	SHEET NO.
338	(112 & 113) WRS-7	DUPAGE	1156	592
CONTRACT NO. 60R30				
ILLINOIS FED. AID PROJECT				