

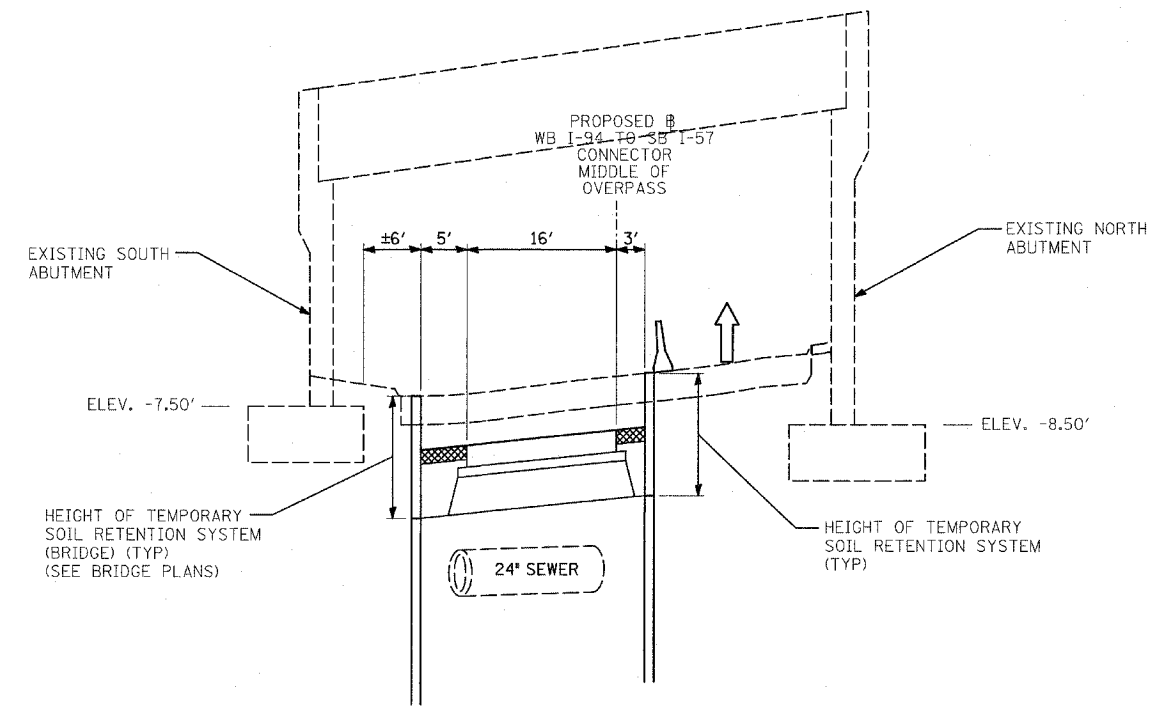



**STAGE 1: CONSTRUCTION AND SOIL RETENTION  
EAST SIDE OF OVERPASS**



**STAGE 1: CONSTRUCTION AND SOIL RETENTION  
MIDDLE OF OVERPASS**

**LEGEND:**

-  TEMPORARY CONCRETE BARRIER
-  TEMPORARY PAVEMENT
-  TRAVEL LANE

**TEMPORARY SOIL RETENTION SCHEDULE ALONG NORTH SIDE OF WB CONNECTOR**

WBX STATION	EXISTING PAV'T ELEV. (FT)	PROPOSED PAV'T ELEV. (FT)	HEIGHT OF RETENTION (ELEV. DIFF. PLUS 3.67' FOR EXCAV.) (FT)	SOIL RETENTION AREA (SF)
* 333+00	-13.23	-13.73	4.17	0.00
* 333+25	-12.80	-13.46	4.33	106.25
* 333+50	-12.31	-13.16	4.52	110.63
* 333+75	-11.81	-12.83	4.69	115.13
* 334+00	-11.30	-12.50	4.87	119.50
* 334+25	-10.78	-12.17	5.06	124.13
* 334+50	-10.27	-11.84	5.24	128.75
* 334+75	-9.75	-11.51	5.43	133.38
* 335+00	-9.21	-11.18	5.64	138.38
* 335+25	-8.63	-10.84	5.88	144.00
* 335+37	-8.35	-10.68	6.00	71.28
* 335+50	-8.06	-10.51	6.12	78.78
* 335+75	-7.54	-10.17	6.30	155.25
* 336+00	-7.02	-9.77	6.42	159.00
* 336+25	-6.45	-9.30	6.52	161.75
* 336+50	-5.90	-8.78	6.55	163.38
* 336+75	-5.35	-8.19	6.51	163.25
* 337+00	-4.81	-7.54	6.40	161.38
* 337+25	-4.24	-6.82	6.25	158.13
* 337+50	-3.67	-6.04	6.04	153.63
* 337+61	-3.43	-5.68	5.92	65.78
* 337+75	-3.07	-5.20	5.80	82.04
* 338+00	-2.43	-4.30	5.54	141.75
* 338+25	-1.84	-3.34	5.17	133.88
* 338+50	-1.23	-2.38	4.82	124.88
* 338+75	-0.68	-1.43	4.42	115.50
* 339+00	-0.10	-0.52	4.09	106.38
* 339+25	0.48	0.33	3.82	98.88
* 339+50	N/A	N/A	0.00	47.75
<b>TEMPORARY SOIL RETENTION SYSTEM TOTAL:</b>				<b>3463.0</b>

\* DENOTES AREAS WHERE THE FULL DEPTH OF THE PROPOSED PAVEMENT IS REQUIRED TO BE RETAINED. THE ADDITIONAL DEPTH OF 3.67 FT IS INCLUDED IN THE HEIGHT OF RETENTION CALCULATION.

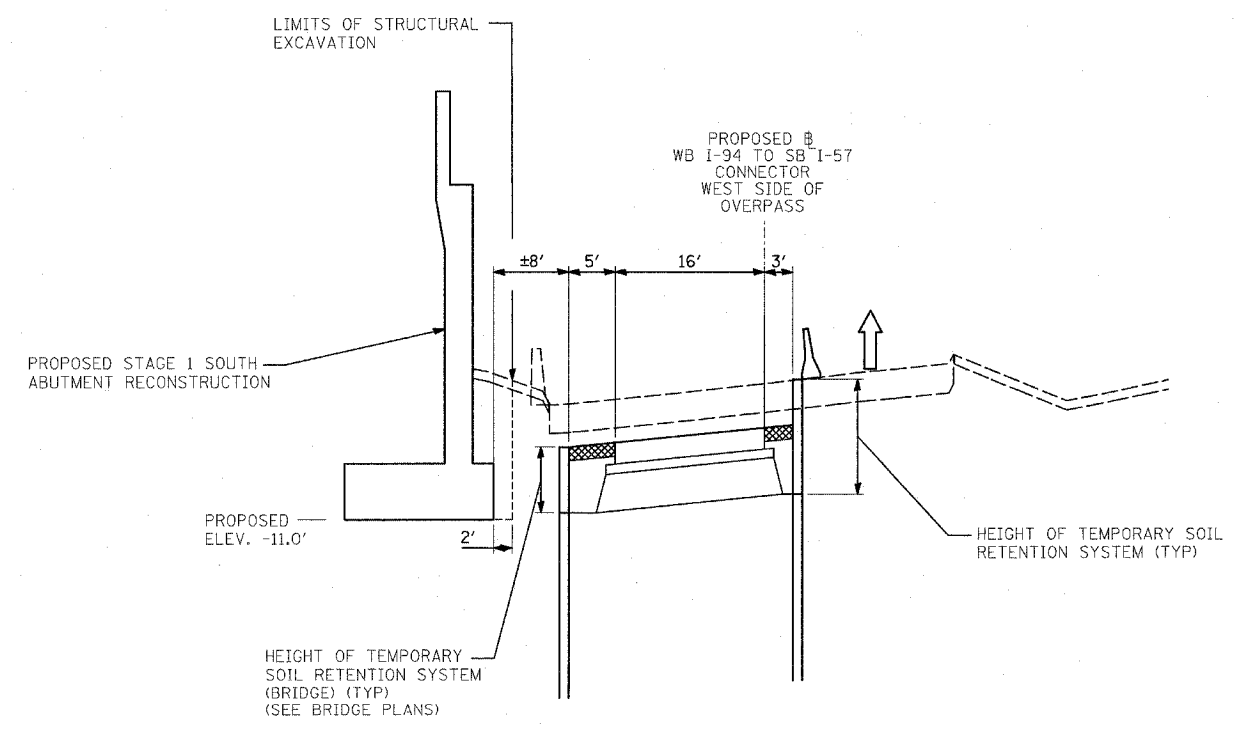

**STAGE 1: CONSTRUCTION AND SOIL RETENTION  
WEST SIDE OF OVERPASS**

REVISIONS	
NAME	DATE

ILLINOIS DEPARTMENT OF TRANSPORTATION  
F.A.I. 94 (DAN RYAN EXPRESSWAY)

MISCELLANEOUS DETAILS  
TEMPORARY SOIL RETENTION  
ALONG THE WB CONNECTOR  
SECTIONS AND SCHEDULE

SCALE: NONE      DRAWN BY: JDF  
DATE: MARCH 7, 2006      CHECKED BY: TGB