

F.A.I. RTE.	SECTION	COUNTY	TOTAL SHEETS	SHEET NO.
57	*	COOK	916	576
STA.		TO STA.		
FED. ROAD DIST. NO. 1		ILLINOIS		FED. AID PROJECT
CONTRACT NO. 62304				
*(1516.1, 1717, & 1818) R-4				

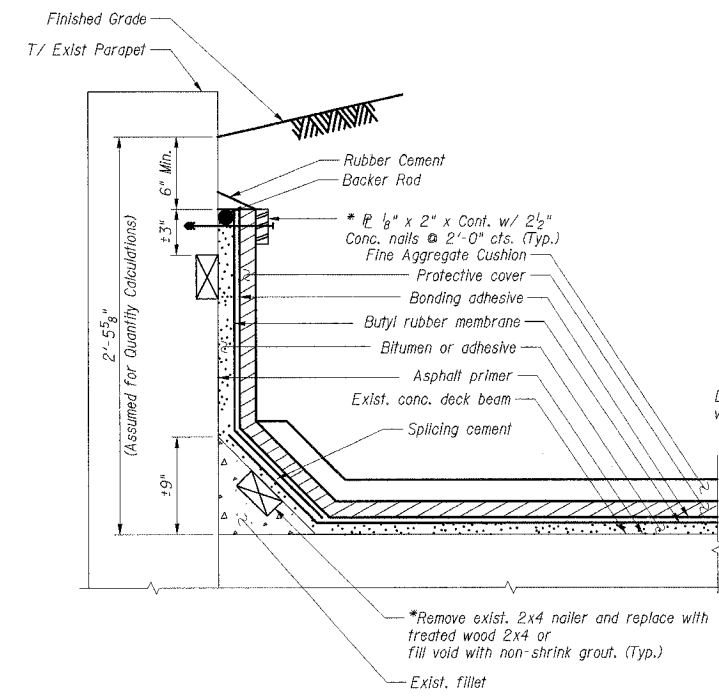

**AT PARAPET**  
\*Cost included with Membrane Waterproofing

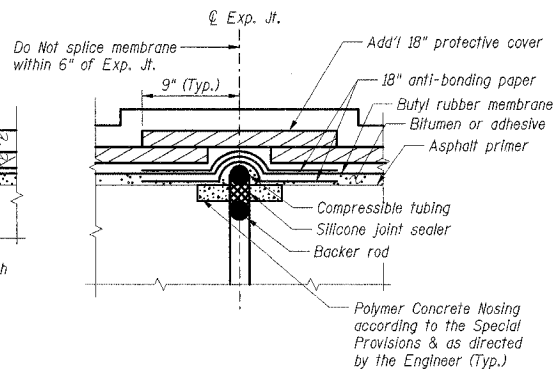

**AT EXPANSION JOINT**  
Diameter of backer rod and compressible tubing to be 25% greater than joint opening at time of installation. The cost of the compressible tubing is included with Silicone Bridge Joint Sealer.

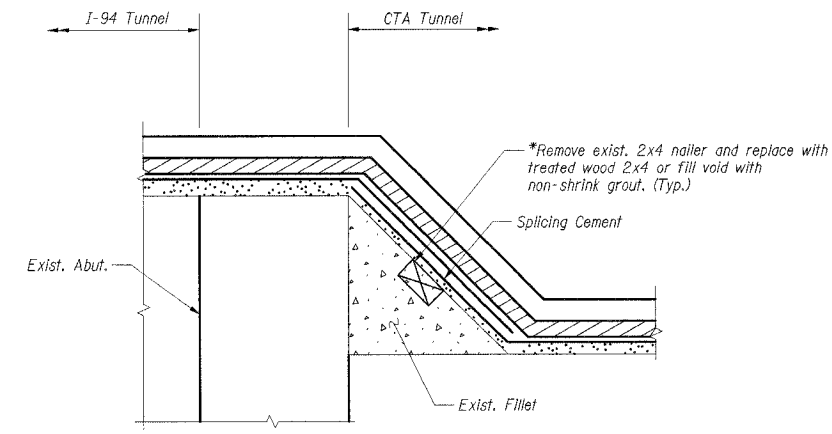

**AT COMMON ABUTMENT**

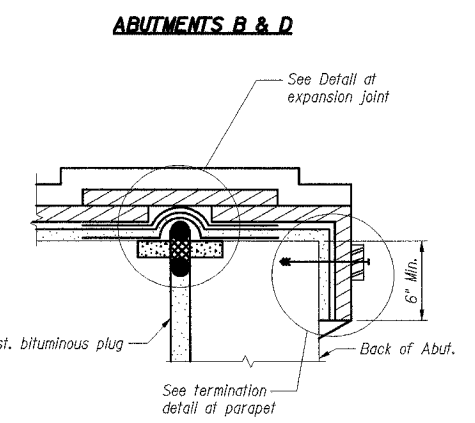
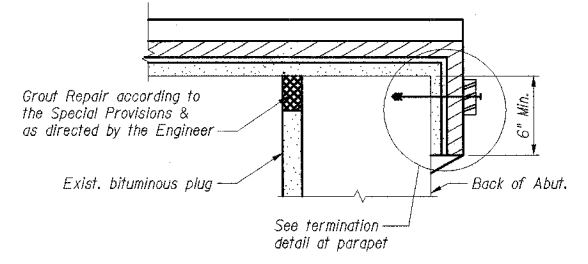

**ABUTMENTS B & D**  
**ABUTMENTS A & C**  
**AT ABUTMENT BACKWALL**

**MEMBRANE WATERPROOFING**

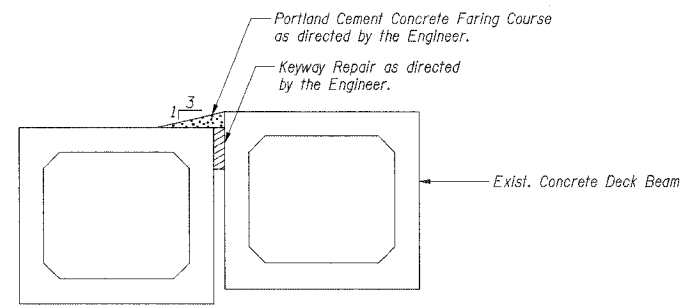

**CONCRETE FARING COURSE & KEYWAY REPAIR DETAIL**

- NOTES:**
1. Prior to installing the new Membrane Waterproofing, existing waterproofing system asphalt planks and loose and de-bonded areas of the existing waterproofing membrane system shall be removed utilizing hand methods which will not damage the deck beams. The cost of removal and disposal of the existing waterproofing membrane system is included with Membrane Waterproofing (Special). See Special Provision for Membrane Waterproofing (Special).
  2. The Contractor shall coordinate membrane waterproofing installation with the Construction Staging shown on the Roadway Plans, according to the Special Provisions, and as directed by the Engineer. The Contractor shall make such provisions as necessary to protect previously installed work and shall minimize the number of membrane laps.

SHT. ST-004

REVISIONS	
NAME	DATE

ILLINOIS DEPARTMENT OF TRANSPORTATION  
F.A.I. ROUTE 57 (INTERSTATE 57) OVER  
F.A.I. ROUTE I-94 SB & CTA TRACKS-BRIDGE REPAIRS  
SN 016-0073  
COOK COUNTY  
SECTION (1516.1, 1717, & 1818) R-4  
MEMBRANE WATERPROOFING DETAILS

DATE: 03/07/06  
DRAWN BY: VV  
CHECKED BY: RDS

**TENG**  
TENG & ASSOCIATES, INC.  
ENGINEERS/ARCHITECTS/PLANNERS  
205 N. MORGAN AVE., CHICAGO, IL 60601  
TELEPHONE: 312.467.8000

UDETG  
 \\FS-0001\FRCL\CVL\DOCUMENT\030806\STRUCT\06\W\DET\004\_B.DGN  
 3-01-2006 15:27:33  
 \\FS-0001\FRCL\CVL\DOCUMENT\030806\STRUCT\06\W\DET\004\_B.DGN  
 3-01-2006 15:27:33