

INDEX OF SHEETS

FOR INDEX OF SHEETS, SEE SHEET NO. 2

PROJECT LOCATED IN THE CITY OF CHICAGO

DAN RYAN EXPRESSWAY:	ADT (2010)	DESIGN SPEED	POSTED SPEED
SB I-94 (DAN RYAN)	140,500	60 MPH	55 MPH
SB I-94 (BISHOP FORD)	87,600	60 MPH	55 MPH
SB I-57	65,800	60 MPH	55 MPH
SB 79TH STREET C-D ENTRANCE RAMP	15,300	45 MPH	40 MPH
SB 83RD STREET C-D EXIT RAMP	6,800	45 MPH	40 MPH
SB 87TH STREET EXIT RAMP	12,600	45 MPH	40 MPH
SB 87TH STREET ENTRANCE RAMP	13,400	45 MPH	40 MPH
SB 95TH STREET EXIT RAMP	11,900	45 MPH	40 MPH
SB WENTWORTH AVE. EXIT RAMP	4,800	45 MPH	40 MPH
SB HALSTED STREET EXIT RAMP	21,300	45 MPH	40 MPH
EB I-57 TO I-94 CROSS-CONNECTOR	22,800	50 MPH	50 MPH

PROPOSED HIGHWAY PLANS

F.A.I. ROUTE 94 (DAN RYAN EXPRESSWAY)

SECTION (1516.1, 1717, & 1818) R-5

PROJECT NO.: *IM-094-3(401)061*

I-57 TO 79TH STREET

SB LANES 1 - 5, SHOULDERS & CTA BARRIER WALL

COOK COUNTY

C-91-095-03

VOL. 1 OF 2

F.A.I. RTE.	SECTION	COUNTY	TOTAL SHEETS	SHEET NO.
94	*	COOK	764	1
FED. ROAD DIST. NO.	ILLINOIS	FED. AID PROJECT		

D-91-421-01 • (1516.1, 1717, & 1818) R-5 **62593**

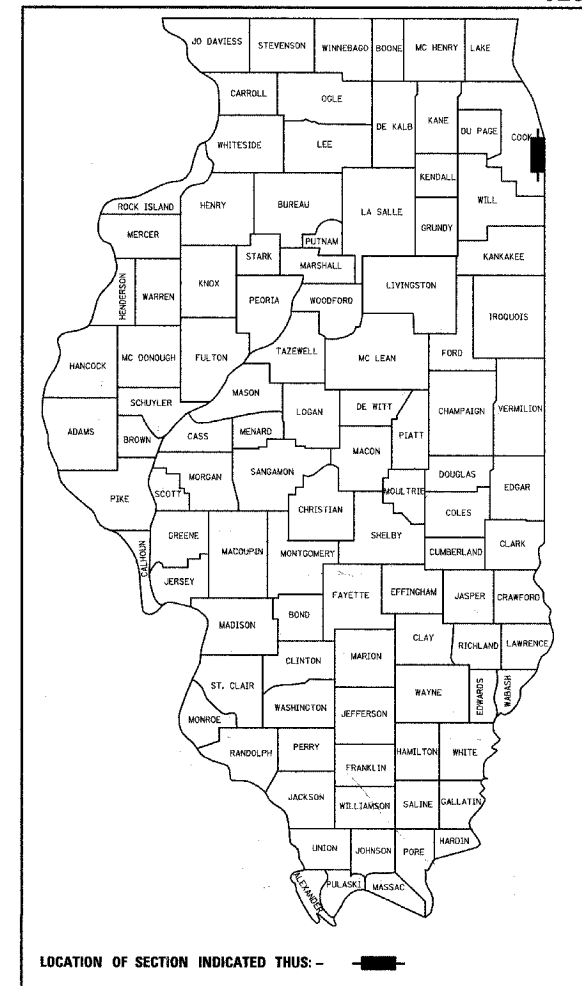

PROJECT DESCRIPTION

THE PROPOSED IMPROVEMENT CONSISTS OF PAVEMENT AND CTA BARRIER WALL RECONSTRUCTION, WIDENING, RAMP TERMINALS, SHOULDERS, AND DRAINAGE MODIFICATIONS ALONG SB I-94 (DAN RYAN & BISHOP FORD) AND SB I-57; AND PAVEMENT RESURFACING ALONG SB I-94 (BISHOP FORD) AND EB I-57 TO I-94 CONNECTOR.

INTERIOR WALL AND CEILING REPAIRS TO:

S.N. 016-0073: SOUTHBOUND BISHOP FORD TUNNEL AND ADJACENT CTA TUNNEL UNDER NORTHBOUND I-57.

SUBSTRUCTURE AND ABUTMENT REPAIRS TO:

S.N. 016-0143: BELT RAILWAY & NORFOLK SOUTHERN BRIDGE OVER SOUTHBOUND AND NORTHBOUND I-94 (DAN RYAN EXPRESSWAY).

S.N. 016-0144 & S.N. 016-0145: CHICAGO RAIL LINK BRIDGES OVER SOUTHBOUND AND NORTHBOUND I-94 (DAN RYAN EXPRESSWAY).

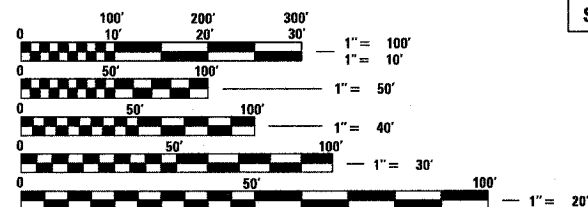

FULL SIZE PLANS HAVE BEEN PREPARED USING STANDARD ENGINEERING SCALES; REDUCED SIZED PLANS WILL NOT CONFORM TO STANDARD SCALES. IN MAKING MEASUREMENTS ON REDUCED PLANS, THE ABOVE SCALES MAY BE USED

DIGGER:
CHICAGO UTILITY ALERT NETWORK
(312) 744-7000

CTA CONTACT:
MARVIN A. WATSON,
GENERAL MANAGER, CONSTRUCTION
(312) 681-3860

CONTRACT NO. 62593

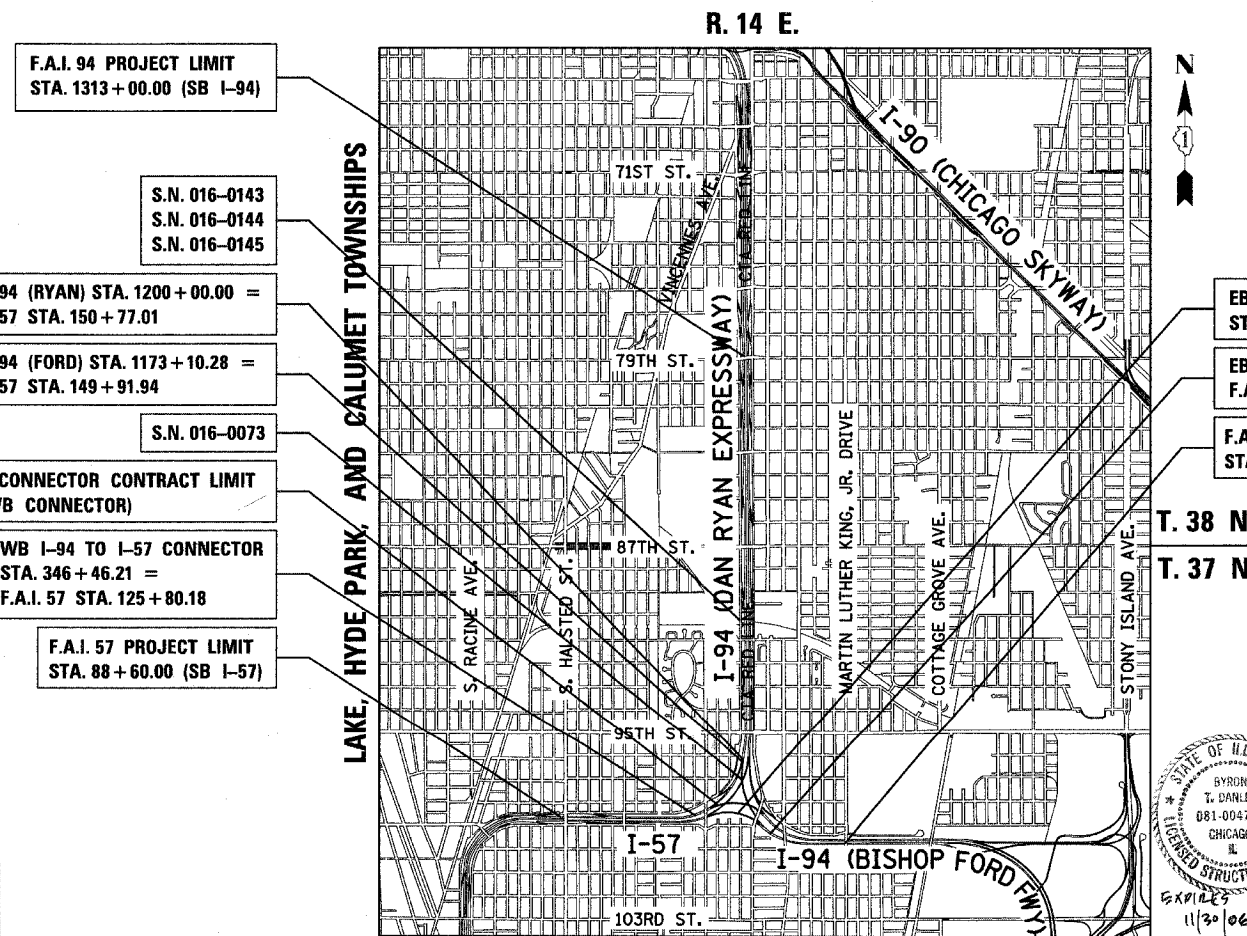

LOCATION MAP

GROSS LENGTH OF PROJECT = 24088.3 FT. = 4.562 MI.
NET LENGTH OF PROJECT = 24088.3 FT. = 4.562 MI.

EB I-57 TO I-94 CONNECTOR CONTRACT LIMIT STA. 415+06.00 (EB CONNECTOR)
EB I-57 TO I-94 CONNECTOR STA. 428+44.62 = F.A.I. 94 (FORD) STA. 1147+23.13
F.A.I. 94 PROJECT LIMIT STA. 1126+90.84 (SB I-94)

F.A.I. 94 PROJECT LIMIT STA. 1313+00.00 (SB I-94)

S.N. 016-0143
S.N. 016-0144
S.N. 016-0145

F.A.I. 94 (RYAN) STA. 1200+00.00 = F.A.I. 57 STA. 150+77.01

F.A.I. 94 (FORD) STA. 1173+10.28 = F.A.I. 57 STA. 149+91.94

S.N. 016-0073

WB I-94 TO I-57 CONNECTOR CONTRACT LIMIT STA. 340+29.15 (WB CONNECTOR)

WB I-94 TO I-57 CONNECTOR STA. 346+46.21 = F.A.I. 57 STA. 125+80.18

F.A.I. 57 PROJECT LIMIT STA. 88+60.00 (SB I-57)

Signed *Dean A. Kiesling*
Dean A. Kiesling, P.E., Ill. Lic. No. 02957
Expires 11-30-2007.
Date *March 1, 2006*

Signed *Phillip D. Frey*
Phillip D. Frey, S.E., Ill. Lic. No. 081-004826
Expires 11-30-2006.
Date *3/1/06*
For Structural Drawings 342-347 AND 519-534

Signed *Thomas Mikolajewski*
Thomas Mikolajewski, P.E., Ill. Lic. No. 062-056151
Expires 11-30-2007.
Date *March 1, 2006*
For Electrical Drawings 441-485

Signed *Phillip D. Frey*
Phillip D. Frey, S.E., Ill. Lic. No. 081-004826
Expires 11-30-2006.
Date *3/1/06*
For Structural Drawings 342-347 AND 519-534

STATE OF ILLINOIS
DEPARTMENT OF TRANSPORTATION
DIVISION OF HIGHWAYS
SUBMITTED *March 2* 20 *06*
Diane M. O'Keefe
DISTRICT ENGINEER
March 24 20 *06*
Mike Kise
ENGINEER OF DESIGN AND ENVIRONMENT
March 24 20 *06*
Milton R. Seay
DIRECTOR, DIVISION OF HIGHWAYS

CONTRACT 23

Rev. 5-10-06

TYLINTERNATIONAL
PRINTED BY THE AUTHORITY OF THE STATE OF ILLINOIS

DISTRICT ONE DESIGN / PROJECT MANAGER:
BRIAN KUTTAB (847) 705 - 4431

SUMMARY OF QUANTITIES

CODE NUMBER	ITEM DESCRIPTION	UNIT	URBAN TOTAL	URBAN - 90% FEDERAL - 10% STATE					STRUCTURAL SFTY-2A
				IM PCC PAVEMENT J000-2A	IM BITUMINOUS PAVEMENT I000-2A	IM LIGHTING Y030-1E	IM I.T.S. Y032-1F	IM NHZ 80% FED. 20% STATE J000-2A	
20100110	TREE REMOVAL (6-15 UNITS DIAMETER)	UNIT	784	775	9				
20100210	TREE REMOVAL (OVER 15 UNITS DIAMETER)	UNIT	116	116					
20101000	TEMPORARY FENCE	FOOT	5961	5601	360				
20200100	EARTH EXCAVATION	CU YD	136021	116,471			19,550		
20200410	EARTH EXCAVATION (SPECIAL)	CU YD	115	115					
20201200	REMOVAL AND DISPOSAL OF UNSUITABLE MATERIAL	CU YD	10875	10875					
20700220	POROUS GRANULAR EMBANKMENT	CU YD	678	526	152				
20700420	POROUS GRANULAR EMBANKMENT, SUBGRADE	CU YD	4401	4401					
20800150	TRENCH BACKFILL	CU YD	4879	3469	1410				
21001000	GEOTECHNICAL FABRIC FOR GROUND STABILIZATION	SQ YD	153634	126,014			27,020		
* 21101615	TOPSOIL FURNISH AND PLACE, 4"	SQ YD	47619	35729	11890				
* 21101630	TOPSOIL FURNISH AND PLACE, 8"	SQ YD	8007	8007					
* 21101645	TOPSOIL FURNISH AND PLACE, 12"	SQ YD	19496	16229	3267				
* 21101825	COMPOST FURNISH AND PLACE, 6"	SQ YD	19149	17951	1198				
* 25000210	SEEDING, CLASS 2A	ACRE	11.75	9.00	2.75				
* 25000400	NITROGEN FERTILIZER NUTRIENT	POUND	1146	898	248				
* 25000500	PHOSPHORUS FERTILIZER NUTRIENT	POUND	1141	893	248				
* 25000600	POTASSIUM FERTILIZER NUTRIENT	POUND	1138	890	248				
* 25000750	MOWING	ACRE	29.25	22.00	7.25				
* 25001800	SEEDING, CLASS 4 (MODIFIED)	ACRE	3.00	3.00					
* 25001820	SEEDING, CLASS 5 (MODIFIED)	ACRE	1.00	0.50	0.50				
* 25002014	SEEDING, CLASS 4A (MODIFIED)	ACRE	1.00	0.50	0.50				
* 25100630	EROSION CONTROL BLANKET	SQ YD	74385	59228	15157				
* 25200200	SUPPLEMENTAL WATERING	UNIT	3910	3128	782				
* 28000200	EARTH EXCAVATION FOR EROSION CONTROL	CU YD	90	60	30				
* 28000250	TEMPORARY EROSION CONTROL SEEDING	POUND	1412	1098	314				
* 28000300	TEMPORARY DITCH CHECKS	EACH	77	61	16				
* 28000510	INLET FILTERS	EACH	21	21					
28001000	AGGREGATE (EROSION CONTROL)	TON	5	2	3				
31101860	SUB-BASE GRANULAR MATERIAL, TYPE B 24"	SQ YD	157503	130,483			27,020		
40600200	BITUMINOUS MATERIALS (PRIME COAT)	TON	14.1	0.1	14.0				
40600300	AGGREGATE (PRIME COAT)	TON	71	1	70				
40600895	CONSTRUCTING TEST STRIP	EACH	2	2					

- * - SPECIALTY ITEM
- - IDOT PAY CODE SFTY-3N
- △ - IDOT PAY CODE Y080.
- - NON-PARTICIPATING

TYLIN INTERNATIONAL

Rev. 5-10-06

Rev.

REVISIONS	
NAME	DATE

ILLINOIS DEPARTMENT OF TRANSPORTATION
 F.A.I. 94 (DAN RYAN EXPRESSWAY)

SUMMARY OF QUANTITIES
 SHEET 1 OF 8

SCALE: NONE
 DATE: MARCH 1, 2006
 DRAWN BY: MPG
 CHECKED BY: TGB

P:\02-27-23\road\023\02-23-01\023.dgn

SUMMARY OF QUANTITIES

CODE NUMBER	ITEM DESCRIPTION	UNIT	URBAN TOTAL	IM URBAN - 90% FEDERAL - 10% STATE						
				PCC PAVEMENT J000-2A	BITUMINOUS PAVEMENT I000-2A	IM LIGHTING Y030-1E	IM I.T.S. Y032-1F	N.H.I. 80% FED. 20% STATE J000-2A	STRUCTURAL SFTY-24 SNO16-0143, 0144, 0145	IM SNO16-0073
40601000	BITUMINOUS REPLACEMENT OVER PATCHES	TON	184		184					
42001300	PROTECTIVE COAT	SQ YD	163,785	160,487	3298					
42100380	CONTINUOUSLY REINFORCED PORTLAND CEMENT CONCRETE PAVEMENT 14"	SQ YD	113317	86,297				27,020		
42101426	LUG SYSTEM COMPLETE 26'	EACH	1	1						
42101436	LUG SYSTEM COMPLETE 36'	EACH	1	1						
44000004	BITUMINOUS SURFACE REMOVAL 1"	SQ YD	21837	21837						
44000006	BITUMINOUS SURFACE REMOVAL 1 1/2"	SQ YD	5465	290	5175					
44000011	BITUMINOUS SURFACE REMOVAL 4"	SQ YD	10570		10570					
44000100	PAVEMENT REMOVAL	SQ YD	109404	109404						
44000106	BITUMINOUS REMOVAL OVER PATCHES 1 1/2"	SQ YD	2194		2194					
44000500	COMBINATION CURB AND GUTTER REMOVAL	FOOT	18173	14289	3884					
44001980	CONCRETE BARRIER REMOVAL	FOOT	6524	5273	1251					
44003510	MEDIAN REMOVAL PARTIAL DEPTH	SQ FT	2940	2940						
44004250	PAVED SHOULDER REMOVAL	SQ YD	29961	13,659	937			15,365		
44004260	PAVED SHOULDER REMOVAL (SPECIAL)	SQ YD	746	746						
44004400	PAVEMENT REMOVAL (SPECIAL)	SQ YD	2338	2338						
44201427	CLASS C PATCHES, TYPE II, 16 INCH	SQ YD	100		100					
44201433	CLASS C PATCHES, TYPE IV, 16 INCH	SQ YD	2033		2033					
44300200	STRIP REFLECTIVE CRACK CONTROL TREATMENT	FOOT	17,527	17,527						
48101200	AGGREGATE SHOULDERS, TYPE B	TON	406	406						
48300400	PORTLAND CEMENT CONCRETE SHOULDERS 9"	SQ YD	794		794					
50102400	CONCRETE REMOVAL	CU YD	2	2						
50200100	STRUCTURE EXCAVATION	CU YD	748	748						
* 50200400	ROCK EXCAVATION FOR STRUCTURES	CU YD	28	28						
50300225	CONCRETE STRUCTURES	CU YD	403	403						
50300300	PROTECTIVE COAT	SQ YD	1326	1326						
50301245	FORMED CONCRETE REPAIR (DEPTH EQUAL TO OR LESS THAN 5")	SQ FT	1850					1569	281	
* 50325305	STRUCTURAL REPAIR OF CONCRETE (DEPTH EQUAL TO OR LESS THAN 5")	SQ FT	1888					1569	319	
50700209	UNTREATED TIMBER LAGGING	SQ FT	2761	2761						
50700211	FURNISHING SOLDIER PILES (HP SECTION)	FOOT	3456	3456						
50800205	REINFORCEMENT BARS, EPOXY COATED	POUND	57950	57950						
550A0340	STORM SEWERS, CLASS A, TYPE 2 12"	FOOT	8416	7038	1378					
550A0360	STORM SEWERS, CLASS A, TYPE 2 15"	FOOT	3081	2369	712					
550A0380	STORM SEWERS, CLASS A, TYPE 2 18"	FOOT	2404	1576	828					

- * - SPECIALTY ITEM
- - IDOT PAY CODE SFTY-3N
- △ - IDOT PAY CODE Y080.
- - NON-PARTICIPATING

TYLIN INTERNATIONAL

△ Rev. 5-10-06

Rev

REVISIONS	
NAME	DATE

ILLINOIS DEPARTMENT OF TRANSPORTATION
F.A.I. 94 (DAN RYAN EXPRESSWAY)

SUMMARY OF QUANTITIES
SHEET 2 OF 8

SCALE: NONE
DATE: MARCH 1, 2006
DRAWN BY: MPG
CHECKED BY: TGB

03/08/2006 12:31:27 PM

SUMMARY OF QUANTITIES

CODE NUMBER	ITEM DESCRIPTION	UNIT	URBAN TOTAL	URBAN - 90% FEDERAL, 10% STATE						
				PCC PAVEMENT J000-2A	BITUMINOUS PAVEMENT I000-2A	LIGHTING Y030-1E	I.T.S. Y032-1F	SIGNING Y002-1C	STRUCTURAL SFTY-2A SNO16-0143 0144, 0145	SNO16-0073
550A0400	STORM SEWERS, CLASS A, TYPE 2 21"	FOOT	323	307	16					
550A0410	STORM SEWERS, CLASS A, TYPE 2 24"	FOOT	1385	489	896					
550A0430	STORM SEWERS, CLASS A, TYPE 2 30"	FOOT	511	225	286					
550A0450	STORM SEWERS, CLASS A, TYPE 2 36"	FOOT	33	33						
550A0480	STORM SEWERS, CLASS A, TYPE 2 48"	FOOT	28	28						
550A0660	STORM SEWERS, CLASS A, TYPE 3 15"	FOOT	565	141	424					
550A0680	STORM SEWERS, CLASS A, TYPE 3 18"	FOOT	274	193	81					
550A0710	STORM SEWERS, CLASS A, TYPE 3 24"	FOOT	570	570						
550A0720	STORM SEWERS, CLASS A, TYPE 3 27"	FOOT	243	243						
550A0730	STORM SEWERS, CLASS A, TYPE 3 30"	FOOT	621	450	171					
550A0750	STORM SEWERS, CLASS A, TYPE 3 36"	FOOT	170	125	45					
550A1030	STORM SEWERS, CLASS A, TYPE 4 30"	FOOT	184		184					
550A1070	STORM SEWERS, CLASS A, TYPE 4 42"	FOOT	13	13						
550A1280	STORM SEWERS, CLASS A, TYPE 5 24"	FOOT	144	144						
550A1340	STORM SEWERS, CLASS A, TYPE 5 42"	FOOT	15	15						
550A1640	STORM SEWERS, CLASS A, TYPE 6 42"	FOOT	6	6						
55100300	STORM SEWER REMOVAL 8"	FOOT	92	92						
55100400	STORM SEWER REMOVAL 10"	FOOT	3187	3097	90					
55100500	STORM SEWER REMOVAL 12"	FOOT	5759	5176	583					
55100700	STORM SEWER REMOVAL 15"	FOOT	203	203	△					
55100900	STORM SEWER REMOVAL 18"	FOOT	156	156						
55101200	STORM SEWER REMOVAL 24"	FOOT	327	327						
55101400	STORM SEWER REMOVAL 30"	FOOT	161	161						
55101600	STORM SEWER REMOVAL 36"	FOOT	385	385						
552A0900	STORM SEWERS JACKED IN PLACE, CLASS A 24"	FOOT	49	49						
552A1100	STORM SEWERS JACKED IN PLACE, CLASS A 30"	FOOT	265	265						
552A1300	STORM SEWERS JACKED IN PLACE, CLASS A 36"	FOOT	115	115						
59000100	EPOXY CRACK SEALING	FOOT	372					331	41	
60107700	PIPE UNDERDRAINS 6"	FOOT	34761	34761						
60108200	PIPE UNDERDRAINS 6" (SPECIAL)	FOOT	912	912						
60201310	CATCH BASINS, TYPE A, 4'-DIAMETER, TYPE 20 FRAME AND GRATE	EACH	277	219	58					
60206905	CATCH BASINS, TYPE C, TYPE 1 FRAME, OPEN LID	EACH	44	35	9					

- * - SPECIALTY ITEM
- - IDOT PAY CODE SFTY-3N
- △ - IDOT PAY CODE Y080.
- ⊙ - NON-PARTICIPATING

TYLIN INTERNATIONAL

REVISIONS	
NAME	DATE

ILLINOIS DEPARTMENT OF TRANSPORTATION
F.A.I. 94 (DAN RYAN EXPRESSWAY)

SUMMARY OF QUANTITIES
SHEET 3 OF 8

SCALE: NONE DRAWN BY: MPG
DATE: MARCH 1, 2006 CHECKED BY: TGB

△ Rev. 5-10-06

PA02373.0000.02.3.023.0703.0000 07/18/2006 12:31:27 PM

SUMMARY OF QUANTITIES

CODE NUMBER	ITEM DESCRIPTION	UNIT	URBAN TOTAL	URBAN - 90% FEDERAL, 10% STATE						
				PCC PAVEMENT J000-2A	BITUMINOUS PAVEMENT I000-2A	LIGHTING Y030-1E	I.T.S. Y032-1F	SIGNING Y002-1C	STRUCTURAL SFTY-2A SNO16-0143 0144, 0145	SNO16-0073
60208210	CATCH BASINS, TYPE C, TYPE 20 FRAME AND GRATE	EACH	2	2						
60218400	MANHOLES, TYPE A, 4'-DIAMETER, TYPE 1 FRAME, CLOSED LID	EACH	21	9	12					
60221100	MANHOLES, TYPE A, 5'-DIAMETER, TYPE 1 FRAME, CLOSED LID	EACH	37	30	7					
60223800	MANHOLES, TYPE A, 6'-DIAMETER, TYPE 1 FRAME, CLOSED LID	EACH	7	4	3					
60237420	INLETS, TYPE A, TYPE 20 FRAME AND GRATE	EACH	6	6						
60250200	CATCH BASINS TO BE ADJUSTED	EACH	50	49	1					
60252800	CATCH BASINS TO BE RECONSTRUCTED	EACH	1	1						
60255500	MANHOLES TO BE ADJUSTED	EACH	72	64	8					
60257900	MANHOLES TO BE RECONSTRUCTED	EACH	13	13						
60500040	REMOVING MANHOLES	EACH	40	32	8					
60500050	REMOVING CATCH BASINS	EACH	179	151	28					
60500060	REMOVING INLETS	EACH	68	63	5					
60500105	FILLING MANHOLES	EACH	2	2						
60500205	FILLING CATCH BASINS	EACH	9	8	1					
60608521	COMBINATION CONCRETE CURB AND GUTTER, TYPE M-2.24	FOOT	337.5	337.5						
60618300	CONCRETE MEDIAN SURFACE, 4 INCH	SQ FT	4606	462	4144					
60618324	CONCRETE MEDIAN SURFACE, 6 INCH (SPECIAL)	SQ FT	7123	5584	1539					
* 63100085	TRAFFIC BARRIER TERMINAL, TYPE 6	EACH	16	12	4					
* 63100167	TRAFFIC BARRIER TERMINAL, TYPE 1, SPECIAL (TANGENT)	EACH	16	12	4					
63200310	GUARDRAIL REMOVAL	FOOT	286	286						
63700805	CONCRETE BARRIER TRANSITION	FOOT	631	556	75					
64200105	SHOULDER RUMBLE STRIP	FOOT	40962	30924	10038					
* 66400560	CHAIN LINK FENCE, 6' (SPECIAL)	FOOT	10031	10031						
* 66402900	CHAIN LINK GATE, 6' X 6' SINGLE	EACH	9	9						
66410300	CHAIN LINK FENCE REMOVAL	FOOT	330	330						
* 66900200	NON-SPECIAL WASTE DISPOSAL	CU YD	43,206	43,206	△					
* 66900450	SPECIAL WASTE PLANS AND REPORTS	L SUM	1	1						
* 66900530	SOIL DISPOSAL ANALYSIS	EACH	2	2						
67000600	ENGINEER'S FIELD LABORATORY	CAL MO	15	15						
67100100	MOBILIZATION	L SUM	1	0.7	0.3					
70102550	TRAFFIC CONTROL AND PROTECTION FOR TEMPORARY DETOUR	EACH	1					1		
70300240	TEMPORARY PAVEMENT MARKING - LINE 6"	FOOT	61030	48120	12910					

- * - SPECIALTY ITEM
- - IDOT PAY CODE SFTY-3N
- △ - IDOT PAY CODE Y080.
- ⊙ - NON-PARTICIPATING

TYLIN INTERNATIONAL

REVISIONS	
NAME	DATE

ILLINOIS DEPARTMENT OF TRANSPORTATION
F.A.I. 94 (DAN RYAN EXPRESSWAY)

**SUMMARY OF QUANTITIES
SHEET 4 OF 8**

SCALE: NONE DRAWN BY: MPG
DATE: MARCH 1, 2006 CHECKED BY: TGB

△ Rev. 5-10-06

03/08/2006 12:31:28 PM

SUMMARY OF QUANTITIES

CODE NUMBER	ITEM DESCRIPTION	UNIT	URBAN TOTAL	URBAN - 90% FEDERAL, 10% STATE						
				PCC PAVEMENT J000-2A	BITUMINOUS PAVEMENT I000-2A	LIGHTING Y030-1E	I.T.S. Y032-1F	SIGNING Y002-1C	STRUCTURAL SFTY-2A SNO16-0143 0144, 0145	SNO16-0073
70300520	PAVEMENT MARKING TAPE, TYPE III, 4"	FOOT	56,088	56,088	△					
70300530	PAVEMENT MARKING TAPE, TYPE III, 5"	FOOT	8077	8077						
70300550	PAVEMENT MARKING TAPE, TYPE III, 8"	FOOT	18,204	18,204	△					
70300560	PAVEMENT MARKING TAPE, TYPE III, 12"	FOOT	2965	2965						
70301000	WORK ZONE PAVEMENT MARKING REMOVAL	SQ FT	98606	82978	15628					
70400100	TEMPORARY CONCRETE BARRIER	FOOT	28130	23070	5060					
70400200	RELOCATE TEMPORARY CONCRETE BARRIER	FOOT	50840	42990	7850					
* 72000100	SIGN PANEL - TYPE 1	SQ FT	55					55		
* 72000200	SIGN PANEL - TYPE 2	SQ FT	100					100		
* 72000300	SIGN PANEL - TYPE 3	SQ FT	475					475		
* 72400310	REMOVE SIGN PANEL - TYPE 1	SQ FT	18					18		
* 72400330	REMOVE SIGN PANEL - TYPE 3	SQ FT	48					48		
* 72800100	TELESCOPING STEEL SIGN SUPPORT	FOOT	85					85		
* 73000100	WOOD SIGN SUPPORT	FOOT	395					395		
* 73300100	OVERHEAD SIGN SUPPORT STRUCTURE - SPAN, TYPE I-A (4'-0" X 4'-6")	FOOT	80					80		
* 73305000	OVERHEAD SIGN STRUCTURE WALKWAY	FOOT	44					44		
* 73400200	DRILLED SHAFT CONCRETE FOUNDATIONS	CU YD	16					16		
* 73600100	REMOVE OVERHEAD SIGN STRUCTURE - SPAN	EACH	1					1		
* 73700300	REMOVE CONCRETE FOUNDATION - OVERHEAD	EACH	5					5		
* 78000200	THERMOPLASTIC PAVEMENT MARKING - LINE 4"	FOOT	11734	1170	10564					
* 78000500	THERMOPLASTIC PAVEMENT MARKING - LINE 8"	FOOT	806		806					
* 78000600	THERMOPLASTIC PAVEMENT MARKING - LINE 12"	FOOT	503	29	474					
* 78003120	PREFORMED PLASTIC PAVEMENT MARKING, TYPE B - LINE 5"	FOOT	2126	147	1979					
* 78005110	EPOXY PAVEMENT MARKING - LINE 4"	FOOT	107783	73089	34694					
* 78005120	EPOXY PAVEMENT MARKING - LINE 5"	FOOT	15458	12369	3089					
* 78005140	EPOXY PAVEMENT MARKING - LINE 8"	FOOT	25687	22618	3069					
* 78005150	EPOXY PAVEMENT MARKING - LINE 12"	FOOT	5360	4630	730					
* 78008200	POLYUREA PAVEMENT MARKING TYPE I - LETTERS AND SYMBOLS	SQ FT	110	110						
* 78008210	POLYUREA PAVEMENT MARKING TYPE I - LINE 4"	FOOT	29479	29479						
* 78008220	POLYUREA PAVEMENT MARKING TYPE I - LINE 5"	FOOT	14771	14771						
* 78008240	POLYUREA PAVEMENT MARKING TYPE I - LINE 8"	FOOT	11817	11817						
* 78008250	POLYUREA PAVEMENT MARKING TYPE I - LINE 12"	FOOT	2448	2448						

- * - SPECIALTY ITEM
- - IDOT PAY CODE SFTY-3N
- △ - IDOT PAY CODE Y080.
- - NON-PARTICIPATING

TYLININTERNATIONAL

REVISIONS	
NAME	DATE

ILLINOIS DEPARTMENT OF TRANSPORTATION
 F.A.I. 94 (DAN RYAN EXPRESSWAY)

SUMMARY OF QUANTITIES
 SHEET 5 OF 8

SCALE: NONE DRAWN BY: MPG
 DATE: MARCH 1, 2006 CHECKED BY: TGB

△ Rev. 5-10-06

PA 02/27/06 12:31:28 PM

SUMMARY OF QUANTITIES

CODE NUMBER	ITEM DESCRIPTION	UNIT	URBAN TOTAL	URBAN - 90% FEDERAL, 10% STATE						
				PCC PAVEMENT J000-2A	BITUMINOUS PAVEMENT I000-2A	LIGHTING Y030-1E	I.T.S. Y032-1F	SIGNING Y002-1C	STRUCTURAL SFTY-3N SNO16-0143 0144, 0145	SNO16-0073
* 78100100	RAISED REFLECTIVE PAVEMENT MARKERS	EACH	1830	1629	201					
* 78200100	MONODIRECTIONAL PRISMATIC BARRIER REFLECTOR	EACH	3852	2816	1036					
* 78200410	GUARDRAIL MARKERS, TYPE A	EACH	64	48	16					
* 78200530	BARRIER WALL MARKERS, TYPE C	EACH	235	200	35					
* 78201000	TERMINAL MARKERS, DIRECT APPLIED	EACH	16	12	4					
* 78300100	PAVEMENT MARKING REMOVAL	SQ FT	16172	10833	5339					
* 80700140	GROUND ROD, 5/8" DIA. X 10 FT.	EACH	11			11				
* 81000600	CONDUIT IN TRENCH, 2" DIA., GALVANIZED STEEL	FOOT	699			699				
* 81000800	CONDUIT IN TRENCH, 3" DIA., GALVANIZED STEEL	FOOT	794			794				
* 81023750	CONDUIT ENCASED IN CONCRETE, 3" DIA., PVC	FOOT	583				583			
* 81400200	HEAVY DUTY HANDHOLE	EACH	22				22			
* 81500200	TRENCH AND BACKFILL FOR ELECTRICAL WORK	FOOT	3047			3047				
* 83600200	LIGHT POLE FOUNDATION, 24" DIAMETER	FOOT	99			99				
* 84200705	LIGHTING FOUNDATION REMOVAL, PARTIAL	EACH	115			115				
* 87900200	DRILL EXISTING HANDHOLE	EACH	11			11				
89502385	REMOVE EXISTING CONCRETE FOUNDATION	EACH	3				3			
X0325291	CONCRETE SEALING	SQ YD	1140						1140	
X0325290	CORED DRAIN HOLES	EACH	64						64	
X0325288	CTA FENCE (SPECIAL)	FOOT	1133	1133						
X0325286	JUNCTION CHAMBER NO. 63	EACH	1	1						
X0325287	JUNCTION CHAMBER NO. 73	EACH	1	1						
* X0325293	PROTECT AND MAINTAIN EXISTING CTA TUNNEL LIGHTING SYSTEM	L SUM	1						1	
* X0325292	PROTECT AND MAINTAIN EXISTING IDOT TUNNEL LIGHTING SYSTEM	L SUM	1						1	
* X0325289	SEEDING, CLASS 5A (MODIFIED)	ACRE	2.75	2.75						
* C2C05818	SHRUB, RHUS AROMATICA GRO-LOW (GROW-LOW FRAGRANT SUMAC), 18" WIDTH, CONTAINER	EACH	560	560						
* C3005924	SHRUB, RHUS GLABRA (SMOOTH SUMAC), 2' HEIGHT, BARE ROOT	EACH	365	365						
* C3006024	SHRUB, RHUS TYPHINA (STAGHORN SUMAC), 2' HEIGHT, BARE ROOT	EACH	430	430						
* E2020061	VINE-PARTHENOCISSUS QUINQUEFOLIA (VIRGINIA CREEPER), 1-GALLON POT	EACH	634	634						
* E2022061	VINE-PARTHENOCISSUS TRICUSPIDATA (BOSTON IVY), 1-GALLON POT	EACH	469	469						
* K0030400	PERENNIAL PLANTS, DAYLILIES	UNIT	7	7						
X0300057	MANHOLES, TYPE A, 6'-DIAMETER, TYPE 1 FRAME, CLOSED LID, RESTRICTOR PLATE	EACH	10	2	8					
⊙ X0320333	ROADWAY CLEANING (SPECIAL)	EACH	28	28						

- * - SPECIALTY ITEM
- - IDOT PAY CODE SFTY-3N
- △ - IDOT PAY CODE Y080.
- ⊙ - NON-PARTICIPATING

TYLIN INTERNATIONAL

REVISIONS	
NAME	DATE

ILLINOIS DEPARTMENT OF TRANSPORTATION
F.A.I. 94 (DAN RYAN EXPRESSWAY)

**SUMMARY OF QUANTITIES
SHEET 6 OF 8**

SCALE: NONE DRAWN BY: MPG
DATE: MARCH 1, 2006 CHECKED BY: TGB

△ Rev. 5-10-06

07/08/2006 12:34:29 PM

SUMMARY OF QUANTITIES

CODE NUMBER	ITEM DESCRIPTION	UNIT	URBAN TOTAL	URBAN - 90% FEDERAL, 10% STATE						
				PCC PAVEMENT J000-2A	BITUMINOUS PAVEMENT I000-2A	LIGHTING Y030-1E	I.T.S. Y032-1F	SIGNING Y002-1C	STRUCTURAL S016-0143, 0144, 0145	SNO16-0073
X0320870	BRACED EXCAVATION	CU YD	954	751	203					
X0321866	REMOVE, STORE AND RE-ERECT SIGN PANEL	SQ FT	525					525		
X0322194	POLYMER MODIFIED PORTLAND CEMENT MORTAR	SQ FT	27							27
X0322256	TEMPORARY INFORMATION SIGNING	SQ FT	1509	128				1381		
X0322671	STABILIZED CONSTRUCTION ENTRANCE	SQ YD	3360	3360						
* X0322859	WEED CONTROL, PRE-EMERGENT GRANULAR HERBICIDE	POUND	16	16						
* X0323426	SEDIMENT CONTROL, DRAINAGE STRUCTURE INLET FILTER CLEANING	EACH	42	42						
* X0323973	SEDIMENT CONTROL, SILT FENCE	FOOT	16599	11737	4862					
* X0323974	SEDIMENT CONTROL, SILT FENCE MAINTENANCE	FOOT	4150	2934	1216					
X0323988	TEMPORARY SOIL RETENTION SYSTEM	SQ FT	11932	11932						
X0324112	BARRIER BASE	FOOT	17,278	15,685	1593					
* X0324455	DRILLING AND SETTING SOLDIER PILES (IN SOIL)	CU FT	9028	9028						
* X0324469	CONDUIT ENCASED, REINFORCED CONCRETE, 2 - 4" DIA., CNC	FOOT	78			78				
* X0324471	CONDUIT ENCASED, REINFORCED CONCRETE, 4 - 4" DIA., CNC	FOOT	243			243				
* X0324646	CONDUIT ENCASED, REINFORCED CONCRETE, 6 - 4" DIA., CNC	FOOT	1605			1605				
X0324697	SOIL STABILIZERS	POUND	221000	221000						
X0324698	APPLYING DUST SUPPRESSION AGENT	UNIT	107	107						
* X0324980	CONDUIT ENCASED, REINFORCED CONCRETE, 3 - 4" DIA., CNC AND 1-2" DIA., CNC 2 WIDE X 2 HIGH	FOOT	97			97				
X0325082	CTA BARRIER REMOVAL	FOOT	9199	9199						
X0325083	CTA FENCE	FOOT	8280	8280						
X0325084	CTA GATES	EACH	9	9						
* X0325130	TUBULAR TRAFFIC SIGN POST	EACH	1					1		
X0712400	TEMPORARY PAVEMENT	SQ YD	11173	9719	1454					
X4066426	BITUMINOUS CONCRETE SURFACE COURSE, SUPERPAVE, MIX "D", N70	TON	652	25	627					
X4066550	POLYMERIZED BITUMINOUS CONCRETE SURFACE COURSE, SUPERPAVE, MIX "F", N105	TON	1690	43	1647					
X4066660	POLYMERIZED BITUMINOUS CONCRETE BINDER COURSE, SUPERPAVE, IL-19, N105	TON	1332		1332					
X4409400	BITUMINOUS SURFACE REMOVAL 1 3/4"	SQ YD	8621	436	8185					
X4834090	PORTLAND CEMENT CONCRETE SHOULDERS 14"	SQ YD	29133	29133						
X6022120	MANHOLES, DROP TYPE, 7'-DIAMETER, TYPE 1 FRAME, CLOSED LID	EACH	3	2	1					
X6022130	MANHOLES, DROP TYPE, 8'-DIAMETER, TYPE 1 FRAME, CLOSED LID	EACH	2	1	1					
X6061001	COMBINATION CONCRETE CURB AND GUTTER, TYPE M-4.48	FOOT	1833.0	1833.0						
X6063600	COMBINATION CONCRETE CURB AND GUTTER, TYPE M-4.24	FOOT	13,226.5	9587.5	3639.0					

- * - SPECIALTY ITEM
- - IDOT PAY CODE SFTY-3N
- △ - IDOT PAY CODE Y080.
- - NON-PARTICIPATING

TYLIN INTERNATIONAL

REVISIONS	
NAME	DATE

ILLINOIS DEPARTMENT OF TRANSPORTATION
 F.A.I. 94 (DAN RYAN EXPRESSWAY)

SUMMARY OF QUANTITIES
 SHEET 7 OF 8

SCALE: NONE
 DATE: MARCH 1, 2006

DRAWN BY: MPG
 CHECKED BY: TGB

Rev. 5-10-06

03/08/2006 12:31:31 PM
 D:\0237\3\road\23\9423587-3a.dgn

SUMMARY OF QUANTITIES

CODE NUMBER	ITEM DESCRIPTION	UNIT	URBAN TOTAL	URBAN - 90% FEDERAL, 10% STATE					
				PCC PAVEMENT 1000-2A	BITUMINOUS PAVEMENT 1000-2A	LIGHTING Y030-1E	I.T.S. Y032-1F	NHI 80% FED 20% STATE 1000-2A	STRUCTURAL SFTY-2A SNO16-0143 0144, 0145 SNO16-0073
X6370910	CONCRETE BARRIER, SINGLE FACE, 32 INCH HEIGHT	FOOT	6568	5994	572				
X6370912	CONCRETE BARRIER, SINGLE FACE, 32 INCH HEIGHT, SPECIAL	FOOT	210		210				
X6370925	CONCRETE BARRIER, SINGLE FACE, 42" (SPECIAL)	FOOT	9123	9123					
X6370935	CONCRETE BARRIER, SINGLE FACE, 32" (MODIFIED)	FOOT	736		736				
X6370940	CONCRETE BARRIER, DOUBLE FACE, 42 INCH HEIGHT	FOOT	10	10					
X6640210	TEMPORARY CHAIN LINK FENCE (PORTABLE)	FOOT	1575	1575					
X6700410	ENGINEER'S FIELD OFFICE, TYPE A (SPECIAL)	CAL MO	24	24					
X7011015	TRAFFIC CONTROL AND PROTECTION (EXPRESSWAYS)	L SUM	1	1					
X7013820	TRAFFIC CONTROL SURVEILLANCE, EXPRESSWAYS	CAL DA	457	457					
X7015000	CHANGEABLE MESSAGE SIGN	CAL MO	160	160					
XX001854	STABILIZED SUB-BASE, 6"	SQ YD	153261	126241			27,020		
XX004200	PORTLAND CEMENT CONCRETE PAVEMENT 14" (JOINTED)	SQ YD	1083	1083					
XX004201	PAVEMENT REINFORCEMENT 14"	SQ YD	113317	86297			27,020		
XX004812	VIDEO TAPING OF SEWERS	FOOT	5619	5619					
XX005489	STEEL CASINGS 48"	FOOT	380	380					
Z0002400	BALLAST	TON	2155	2155					
<input checked="" type="checkbox"/> Z0010605	CLEANING DRAINAGE SYSTEM	L SUM	1						1
Z0013798	CONSTRUCTION LAYOUT	L SUM	1	0.7	0.3				
Z0013825	CONTROLLED LOW-STRENGTH MATERIAL	CU YD	344	283	61				
<input type="checkbox"/> Z0030250	IMPACT ATTENUATORS, TEMPORARY (NON-REDIRECTIVE), TEST LEVEL 3	EACH	9	9					
<input type="checkbox"/> Z0030280	IMPACT ATTENUATORS, TEMPORARY (SEVERE USE, NARROW), TEST LEVEL 3	EACH	1	1					
<input type="checkbox"/> Z0030350	IMPACT ATTENUATORS, RELOCATE (NON-REDIRECTIVE), TEST LEVEL 3	EACH	24	21	3				
<input type="checkbox"/> Z0030360	IMPACT ATTENUATORS, RELOCATE (SEVERE USE, NARROW), TEST LEVEL 3	EACH	1	1					
Z0040530	PIPE UNDERDRAIN REMOVAL	FOOT	34,700	34,700					
Z0048665	RAILROAD PROTECTIVE LIABILITY INSURANCE	L SUM	1	0.5	0.1			0.3	0.1
<input checked="" type="checkbox"/> Z0056220	SAND MODULE IMPACT ATTENUATOR TO BE REMOVED	EACH	22	11	11				
Z0068400	STEEL CASINGS 42"	FOOT	49	49					
<input checked="" type="checkbox"/> Z0076600	TRAINERS	HOUE	1500	1500					

- * - SPECIALTY ITEM
- IDOT PAY CODE SFTY-3N
- IDOT PAY CODE Y080.
- NON-PARTICIPATING

TYLIN INTERNATIONAL

REVISIONS	
NAME	DATE

ILLINOIS DEPARTMENT OF TRANSPORTATION
 F.A.I. 94 (DAN RYAN EXPRESSWAY)

SUMMARY OF QUANTITIES
 SHEET 8 OF 8

SCALE: NONE
 DATE: MARCH 1, 2006

DRAWN BY: MPG
 CHECKED BY: TGB

Rev. 5-10-06

12-31-06 PM

F.A.I. RTE.	SECTION	COUNTY	TOTAL SHEETS	SHEET NO.
94		COOK	764	15
STA. 1126+91 (SB FORD) TO STA. 1313+00 (SB RYAN)				
FED. ROAD DIST. NO. ILLINOIS FED. AID PROJECT				
• (1516.1, 1717, & 1818) R-5				

EXISTING PIPE UNDERDRAIN (REMOVAL TO BE PAID FOR SEPARATELY. SEE SPECIAL PROVISION "PIPE UNDERDRAIN REMOVAL")

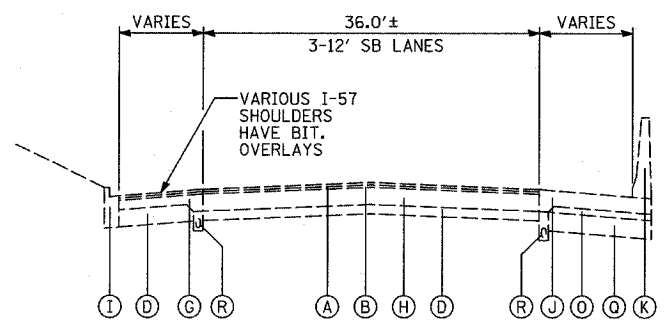

EXISTING SB I-57 MAINLINE PAVEMENT
WEST OF PARNELL AVENUE

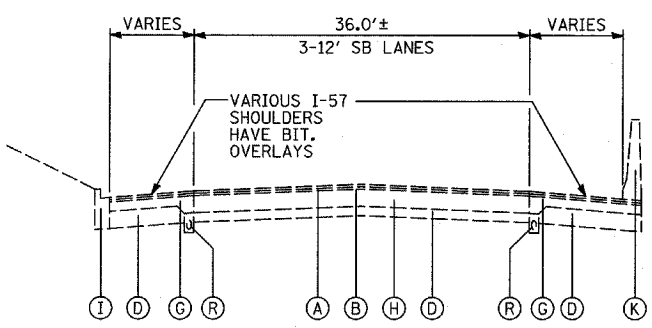

EXISTING SB I-57 MAINLINE PAVEMENT
BETWEEN PARNELL AND AVENUE WENTWORTH AVENUE

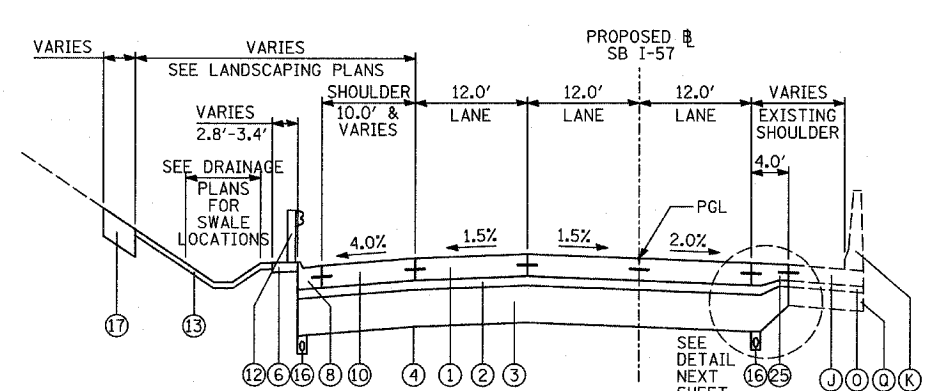

PROPOSED SB I-57 MAINLINE PAVEMENT
EAST OF HALSTED STREET

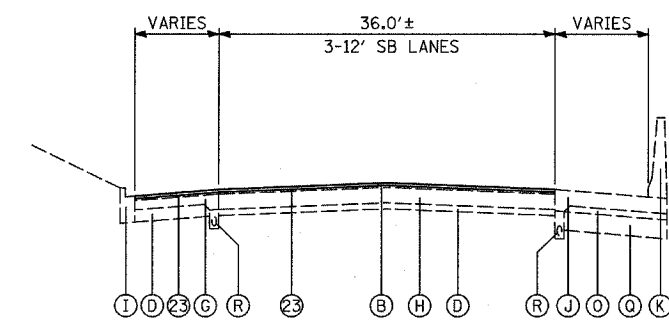

PROPOSED SB I-57 MAINLINE PAVEMENT
RESURFACING WEST OF HALSTED STREET

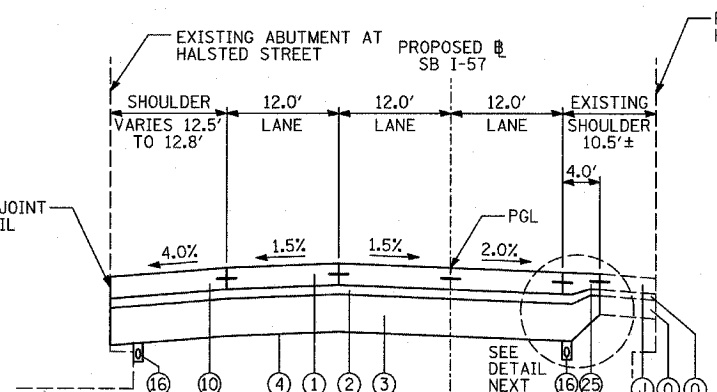

PROPOSED SB I-57 MAINLINE PAVEMENT
AT HALSTED STREET OVERPASS
(SEE CROSS-STREET OVERPASS FOOTING DETAILS)

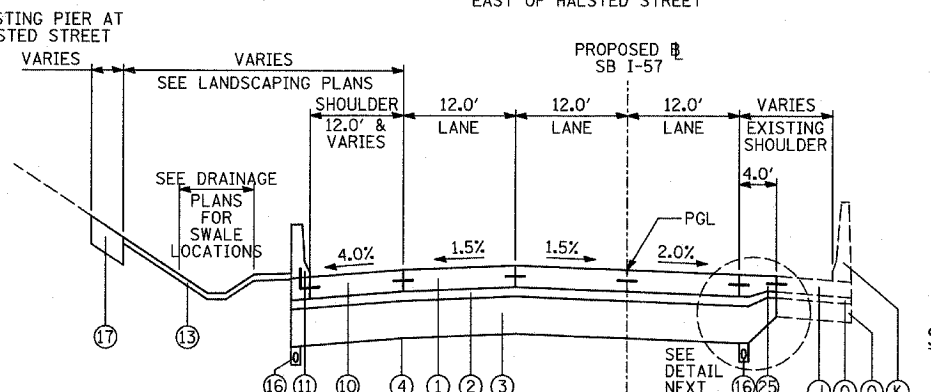

PROPOSED SB I-57 MAINLINE PAVEMENT
EAST OF HALSTED STREET

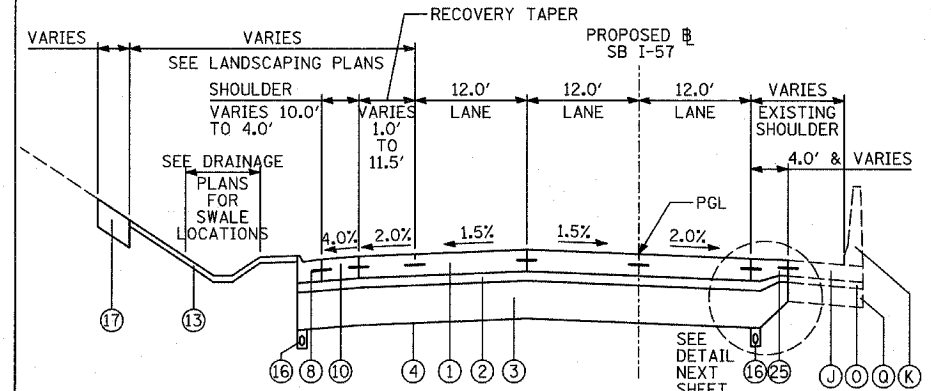

PROPOSED SB I-57 MAINLINE PAVEMENT
BETWEEN HALSTED STREET AND HALSTED STREET EXIT RAMP

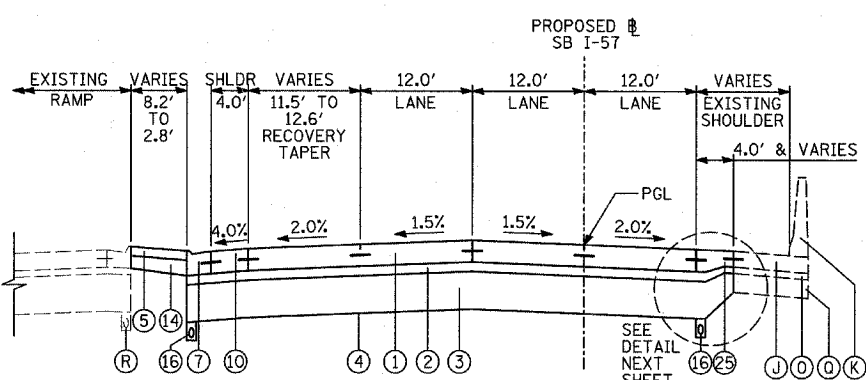

PROPOSED SB I-57 MAINLINE PAVEMENT
AT HALSTED STREET EXIT RAMP GORE

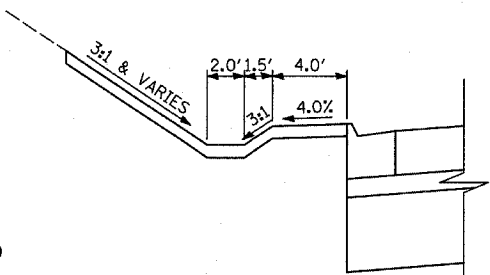

DITCH DETAIL

EXISTING LEGEND ALL EXISTING PAVEMENT DEPTHS ARE FROM AS-BUILT PLANS AND ARE SUBJECT TO CHANGE

- (A) BIT CONC SURFACE COURSE, 1 1/2"±
- (B) BIT CONC BINDER COURSE, 1 1/2"±
- (C) BIT CONC BINDER COURSE, 4 3/4"±
- (D) SUB-BASE GRANULAR MATERIAL, 4"±
- (E) SUB-BASE GRANULAR MATERIAL, 6"±
- (F) CRUSHED STONE, 5"±
- (G) PCC SHOULDERS, 9"±
- (H) PCC BASE COURSE, 9"±
- (I) COMB CONC CURB & GUTTER
- (J) PCC PAVEMENT, 10"± (W/ PAVEMENT FABRIC, 80 LBS±/100 SF)
- (K) CONCRETE BARRIER WALL
- (L) PCC SHOULDERS, 11"±
- (M) CTA BALLAST STONE; REGRADE AS NECESSARY (INCLUDE REGRADING IN THE COST OF "CONCRETE BARRIER, SINGLE FACE, 42 INCH HEIGHT (SPECIAL)")
- (N) JOINTED PCC PAVEMENT, 11"±
- (O) STABILIZED SUB-BASE, 4"±
- (P) SUB-BASE GRANULAR MATERIAL, 24"±
- (Q) SUB-BASE GRANULAR MATERIAL, 12"±

STRUCTURAL PAVEMENT DESIGN INFORMATION

STRUCTURAL DESIGN TRAFFIC:	YEAR = 2020
PV = 322,920	SU = 7,020
MU = 21,060	
ROAD/STREET CLASSIFICATION:	CLASS 1
PERCENT OF STRUCTURAL DESIGN TRAFFIC IN DESIGN LANE:	
P = 8%	S = 37%
M = 37%	
TRAFFIC FACTOR:	ACTUAL TF = 116.08
AC TYPE = N/A	MINIMUM TF = 8.26
AC GRADE:	BINDER = -
	SURFACE = -
SUBGRADE SUPPORT RATING:	SSR = 2.00
ILLINOIS BEARING RATIO:	IBR = 3.00

BITUMINOUS MIXTURE REQUIREMENT

ITEM	AC TYPE	VOIDS	RAP %
SHOULDER RESURFACING 1 1/2" & 1 3/4" DEPTH: BITUMINOUS CONCRETE SURFACE COURSE, SUPERPAVE, MIX "D", N70	PG 64-22	4%±70 Gyr.	10
MAINLINE RESURFACING 1 3/4" DEPTH: POLY. BIT. CONC. SURFACE COURSE, SUPERPAVE, MIX "F", N105	SBS/SBR PG 76-22	4%±105 Gyr.	0
4" DEPTH: POLY. BIT. CONC. SURFACE COURSE, SUPERPAVE, MIX "F", N105 POLY. BIT. CONC. BINDER COURSE, SUPERPAVE, IL-19, N105	SBS/SBR PG 76-22 SBS/SBR PG 76-22	4%±105 Gyr 4%±105 Gyr	0 0
TEMPORARY PAVEMENT POLY. BIT. CONC. SURFACE COURSE, SUPERPAVE, MIX "F", N105 POLY. BIT. CONC. BINDER COURSE, SUPERPAVE, IL-19, N105	SBS/SBR PG 76-22 SBS/SBR PG 76-22	4%±105 Gyr 4%±105 Gyr	0 0
STABILIZED SUBBASE, 6"	PG 58-22	3%±50 Gyr	25
BITUMINOUS REPLACEMENT OVER PATCHES	PG 64-22	4%±70 Gyr	15

THE UNIT WEIGHT USED TO CALCULATE ALL BITUMINOUS SURFACE MIXTURES IS 112 LB/SQ YD./IN.

REVISIONS	
NAME	DATE

ILLINOIS DEPARTMENT OF TRANSPORTATION
F.A.I. 94 (DAN RYAN EXPRESSWAY)
EXISTING & PROPOSED TYPICAL SECTIONS
SB I-57
(SHEET 1 OF 8)

SCALE: NONE
DATE: MARCH 1, 2006
DRAWN BY: MPG
CHECKED BY: TGB

POTENTIAL UNDERCUT

"POROUS GRANULAR EMBANKMENT, SUBGRADE" (PGES) HAS BEEN RECOMMENDED FOR USE AT LOCATIONS WITH SOILS THAT TEND TO BE UNSTABLE OR UNSUITABLE. THE ACTUAL NEED FOR REMOVAL AND REPLACEMENT WITH PGES WILL BE DETERMINED IN THE FIELD AT THE TIME OF CONSTRUCTION BY THE GEOTECHNICAL ENGINEER. ALL POTENTIALLY UNSTABLE SOILS SHOULD BE TESTED WITH A STATIC CONE PENETROMETER AND TREATED IN ACCORDANCE WITH ARTICLE 303.13 AND THE UNDERCUT GUIDELINES IN THE IDOT SUBGRADE STABILITY MANUAL. IF UNSTABLE AND/OR UNSUITABLE MATERIALS ARE ENCOUNTERED, THE SOIL SHALL BE REMOVED AND REPLACED WITH PGES AS DETERMINED BY THE GEOTECHNICAL ENGINEER. IF UNSTABLE AND/OR UNSUITABLE MATERIAL IS NOT ENCOUNTERED, THEN THE QUANTITY SHALL BE DEDUCTED AND NO ADDITIONAL COMPENSATION WILL BE DUE THE CONTRACTOR.

(SEE SCHEDULE OF QUANTITIES FOR LOCATIONS)

NOTES:

- REFER TO PAVEMENT JOINTING AND ELEVATION PLANS FOR DESCRIPTIONS AND DETAILS OF PAVEMENT JOINTS.

PROPOSED LEGEND

- ① CONTINUOUSLY REINFORCED PORTLAND CEMENT CONCRETE PAVEMENT 14" & PAVEMENT REINFORCEMENT, 14"
- ② STABILIZED SUB-BASE, 6" (BITUMINOUS AGGREGATE MIXTURE)
- ③ SUB-BASE GRANULAR MATERIAL, TYPE B 24"
- ④ GEOTECHNICAL FABRIC FOR GROUND STABILIZATION
- ⑤ CONCRETE MEDIAN SURFACE, 6 INCH (SPECIAL)
- ⑥ CONCRETE MEDIAN SURFACE, 6 INCH (SPECIAL) (WITHOUT STAMPED PATTERN)
- ⑦ COMBINATION CONCRETE CURB AND GUTTER, TYPE M-2.24
- ⑧ COMBINATION CONCRETE CURB AND GUTTER, TYPE M-4.24
- ⑨ COMBINATION CONCRETE CURB AND GUTTER, TYPE M-4.48
- ⑩ PORTLAND CEMENT CONCRETE SHOULDERS 14"

- ⑪ CONCRETE BARRIER, SINGLE FACE, 32 INCH HEIGHT; BARRIER BASE; BARRIER WALL MARKERS (PER IDOT STD. 635001 & 635006)
- ⑫ TRAFFIC BARRIER TERMINAL, TYPE VARIES
- ⑬ TOPSOIL FURNISH AND PLACE, 4"; SEEDING, CLASS 2A; EROSION CONTROL BLANKET
- ⑭ AGGREGATE FILL (INCLUDED IN THE COST OF "CONCRETE MEDIAN SURFACE, 6" (SPECIAL)") (MATCH DEPTH TO ADJACENT CURB & GUTTER)
- ⑮ CONCRETE BARRIER, SINGLE FACE, 42 INCH HEIGHT (SPECIAL); BARRIER BASE; CTA FENCE (SEE DETAILS); BARRIER WALL MARKERS (PER IDOT STD. 635001 & 635006)
- ⑯ PIPE UNDERDRAIN, 6" (SEE DETAILS)
- ⑰ TOPSOIL FURNISH AND PLACE, 12"; COMPOST FURNISH AND PLACE, 6"; EROSION CONTROL BLANKET; SEEDING (SEE PLAN FOR CLASS)
- ⑱ ELECTRICAL DUCTBANK (SEE ELECTRICAL INFRASTRUCTURE PLANS)
- ⑲ CONCRETE BARRIER, SINGLE FACE, 32 INCH HEIGHT (MODIFIED); BARRIER BASE; BARRIER WALL MARKERS (PER IDOT STD. 635001 & 635006)
- ⑳ PORTLAND CEMENT CONCRETE SHOULDERS 9"
- ㉑ 1 1/2" SHOULDER RESURFACING: BITUMINOUS CONCRETE SURFACE COURSE, SUPERPAVE, MIX "D", N70, 1 1/2"
- ㉒ 1 3/4" SHOULDER RESURFACING: BITUMINOUS CONCRETE SURFACE COURSE, SUPERPAVE, MIX "D", N70, 1 3/4"
- ㉓ 1 3/4" MAINLINE RESURFACING: POLYMERIZED BITUMINOUS CONCRETE SURFACE COURSE, SUPERPAVE, MIX "F", N105, 1 3/4"
- ㉔ 4" MAINLINE RESURFACING: POLYMERIZED BITUMINOUS CONCRETE SURFACE COURSE, SUPERPAVE, MIX "F", N105, 1 3/4"; POLYMERIZED BITUMINOUS CONCRETE BINDER COURSE, SUPERPAVE, IL-19, N105, 2 1/4"
- ㉕ PORTLAND CEMENT CONCRETE PAVEMENT, 14" (JOINTED)

TYLIN INTERNATIONAL

05/04/2006 04:56:09 PM

F.A.I. RTE.	SECTION	COUNTY	TOTAL SHEETS	SHEET NO.
94		COOK	764	16
STA. 88+60 (SB I-57) TO STA. 1313+00 (SB RYAN)				
FED. ROAD DIST. NO. ILLINOIS FED. AID PROJECT				
(1516.1, 1717, & 1818) R-5				
62593				

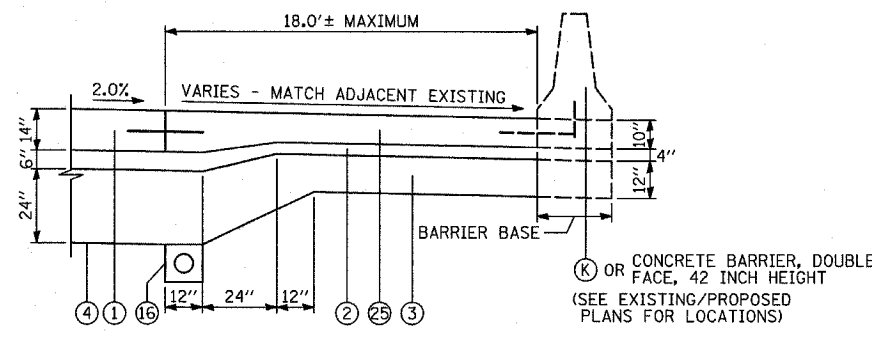
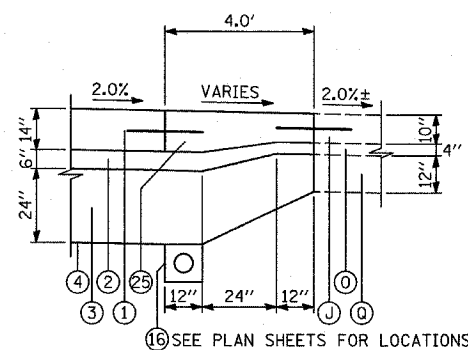
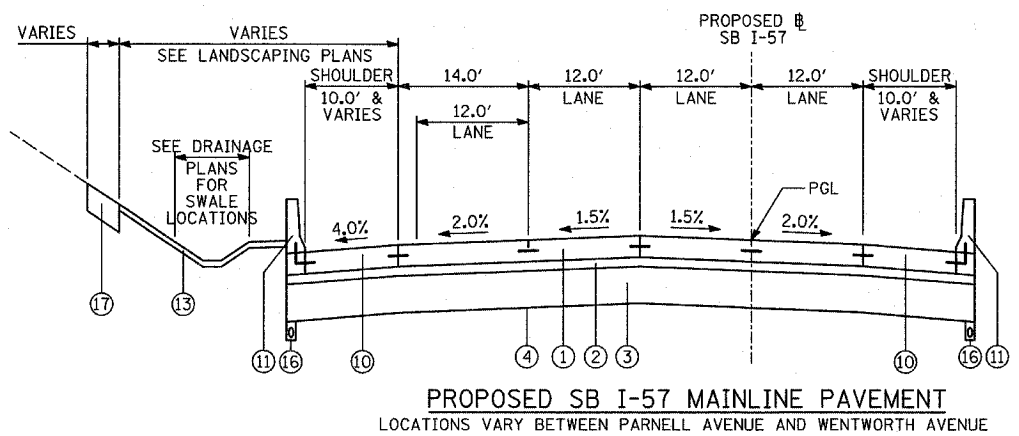
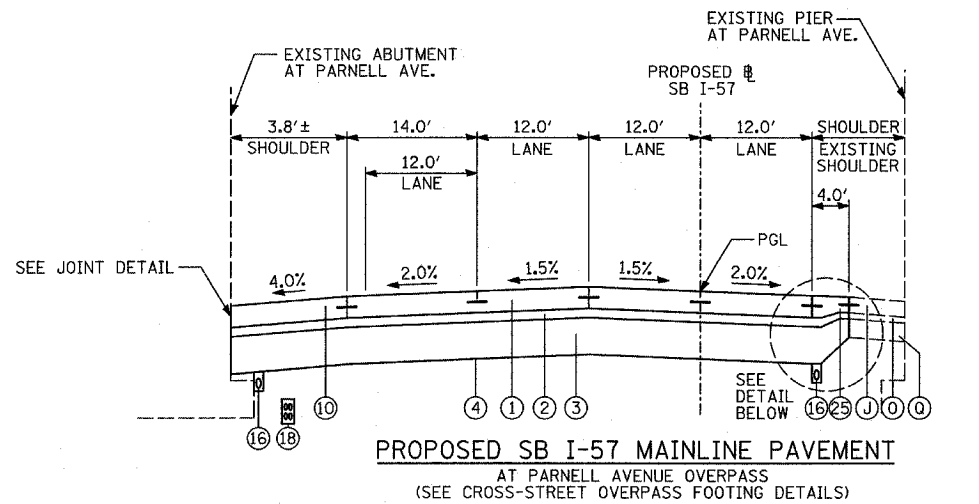
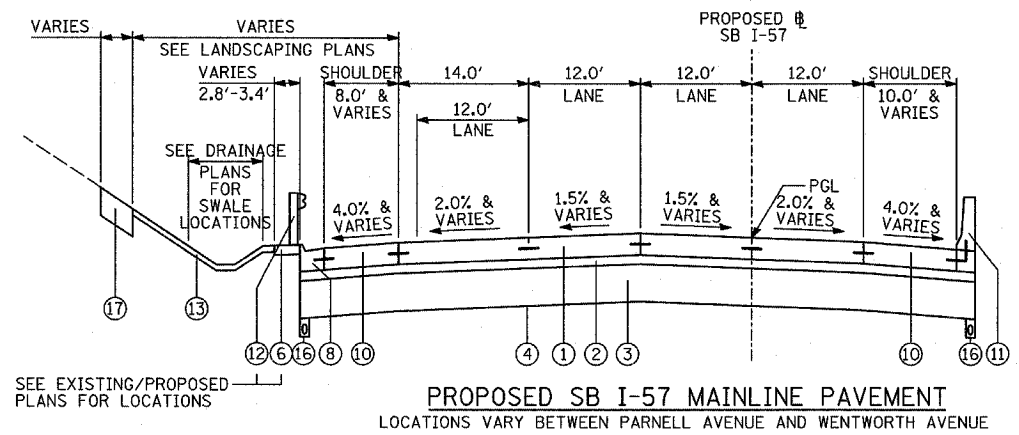
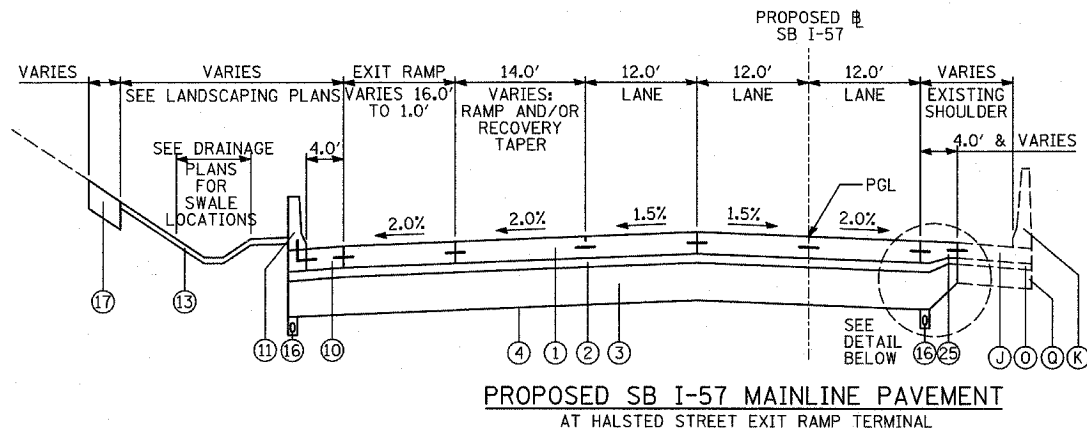
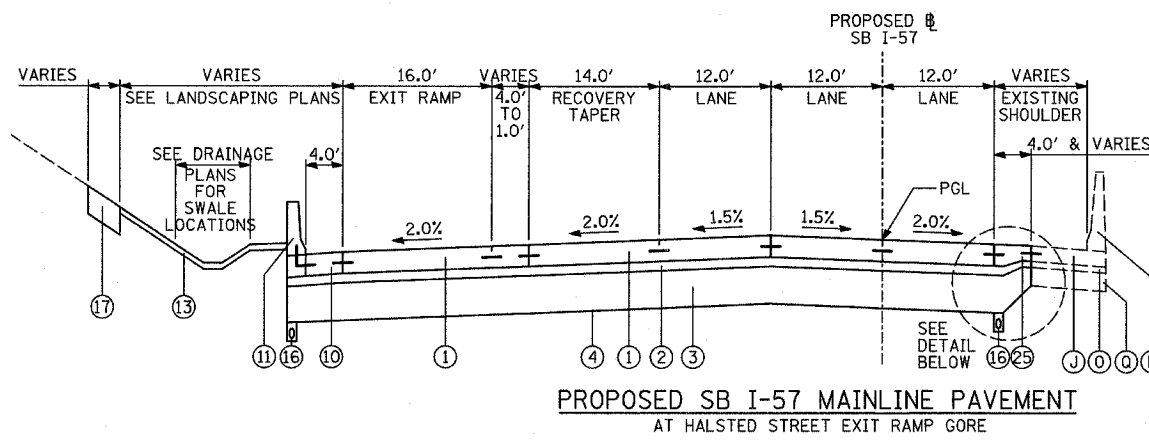
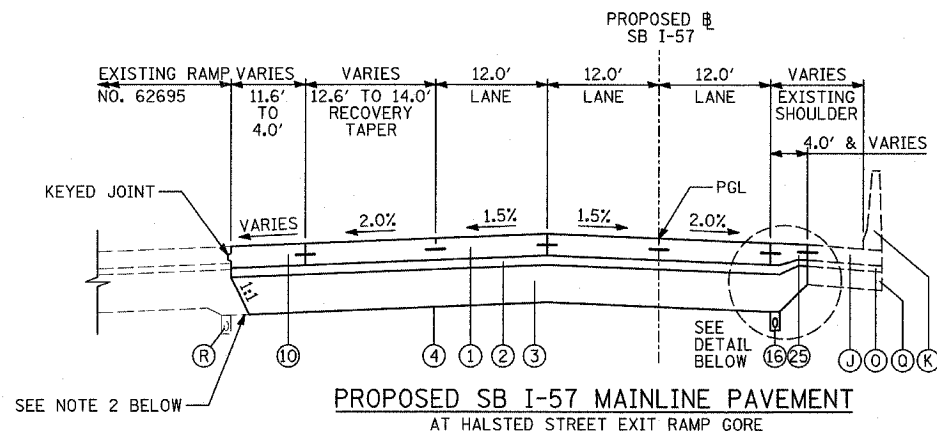

PROPOSED LEGEND

- ① CONTINUOUSLY REINFORCED PORTLAND CEMENT CONCRETE PAVEMENT 14" & PAVEMENT REINFORCEMENT, 14"
- ② STABILIZED SUB-BASE, 6" (BITUMINOUS AGGREGATE MIXTURE)
- ③ SUB-BASE GRANULAR MATERIAL, TYPE B 24"
- ④ GEOTECHNICAL FABRIC FOR GROUND STABILIZATION
- ⑤ CONCRETE MEDIAN SURFACE, 6 INCH (SPECIAL)
- ⑥ CONCRETE MEDIAN SURFACE, 6 INCH (SPECIAL) (WITHOUT STAMPED PATTERN)
- ⑦ COMBINATION CONCRETE CURB AND GUTTER, TYPE M-2.24
- ⑧ COMBINATION CONCRETE CURB AND GUTTER, TYPE M-4.24
- ⑨ COMBINATION CONCRETE CURB AND GUTTER, TYPE M-4.48
- ⑩ PORTLAND CEMENT CONCRETE SHOULDERS 14"
- ⑪ CONCRETE BARRIER, SINGLE FACE, 32 INCH HEIGHT; BARRIER BASE; BARRIER WALL MARKERS (PER IDOT STD. 635001 & 635006)
- ⑫ TRAFFIC BARRIER TERMINAL, TYPE VARIES
- ⑬ TOPSOIL FURNISH AND PLACE, 4"; SEEDING, CLASS 2A; EROSION CONTROL BLANKET
- ⑭ AGGREGATE FILL (INCLUDED IN THE COST OF "CONCRETE MEDIAN SURFACE, 6" (SPECIAL)") (MATCH DEPTH TO ADJACENT CURB & GUTTER)
- ⑮ CONCRETE BARRIER, SINGLE FACE, 42 INCH HEIGHT (SPECIAL); BARRIER BASE; CTA FENCE (SEE DETAILS); BARRIER WALL MARKERS (PER IDOT STD. 635001 & 635006)
- ⑯ PIPE UNDERDRAIN, 6" (SEE DETAILS)
- ⑰ TOPSOIL FURNISH AND PLACE, 12"; COMPOST FURNISH AND PLACE, 6"; EROSION CONTROL BLANKET; SEEDING (SEE PLAN FOR CLASS)
- ⑱ ELECTRICAL DUCTBANK (SEE ELECTRICAL INFRASTRUCTURE PLANS)
- ⑲ CONCRETE BARRIER, SINGLE FACE, 32 INCH HEIGHT (MODIFIED); BARRIER BASE; BARRIER WALL MARKERS (PER IDOT STD. 635001 & 635006)
- ⑳ PORTLAND CEMENT CONCRETE SHOULDERS 9"
- ㉑ 1/2" SHOULDER RESURFACING; BITUMINOUS CONCRETE SURFACE COURSE, SUPERPAVE, MIX "D", N70, 1/2"
- ㉒ 1 3/4" SHOULDER RESURFACING; BITUMINOUS CONCRETE SURFACE COURSE, SUPERPAVE, MIX "D", N70, 1 3/4"
- ㉓ 1 3/4" MAINLINE RESURFACING; POLYMERIZED BITUMINOUS CONCRETE SURFACE COURSE, SUPERPAVE, MIX "F", N105, 1 3/4"
- ㉔ 4" MAINLINE RESURFACING; POLYMERIZED BITUMINOUS CONCRETE SURFACE COURSE, SUPERPAVE, MIX "F", N105, 1 3/4"; POLYMERIZED BITUMINOUS CONCRETE BINDER COURSE, SUPERPAVE, 1L-19, N105, 2 1/4"
- ㉕ PORTLAND CEMENT CONCRETE PAVEMENT, 14" (JOINTED)

EXISTING LEGEND ALL EXISTING PAVEMENT DEPTHS ARE FROM AS-BUILT PLANS AND ARE SUBJECT TO CHANGE

- (A) BIT CONC SURFACE COURSE, 1 1/2"±
- (B) BIT CONC BINDER COURSE, 1 1/2"±
- (C) BIT CONC BINDER COURSE, 4 3/4"±
- (D) SUB-BASE GRANULAR MATERIAL, 4"±
- (E) SUB-BASE GRANULAR MATERIAL, 6"±
- (F) CRUSHED STONE, 5"±
- (G) PCC SHOULDERS, 9"±
- (H) PCC BASE COURSE, 9"±
- (I) COMB CONC CURB & GUTTER
- (J) PCC PAVEMENT, 10"± (W/ PAVEMENT FABRIC, 80 LBS±/100 SF)
- (K) CONCRETE BARRIER WALL
- (L) PCC SHOULDERS, 11"±
- (M) CTA BALLAST STONE; REGRADE AS NECESSARY (INCLUDE REGRADE IN THE COST OF "CONCRETE BARRIER, SINGLE FACE, 42 INCH HEIGHT (SPECIAL)")
- (N) JOINTED PCC PAVEMENT, 11"±
- (O) STABILIZED SUB-BASE, 4"±
- (P) SUB-BASE GRANULAR MATERIAL, 24"±
- (Q) SUB-BASE GRANULAR MATERIAL, 12"±

(R) EXISTING PIPE UNDERDRAIN (REMOVAL TO BE PAID FOR SEPARATELY. SEE SPECIAL PROVISION "PIPE UNDERDRAIN REMOVAL")

REVISIONS	
NAME	DATE

ILLINOIS DEPARTMENT OF TRANSPORTATION
F.A.I. 94 (DAN RYAN EXPRESSWAY)

PROPOSED TYPICAL SECTIONS
SB I-57
(SHEET 2 OF 8)

SCALE: NONE DRAWN BY: MPG
DATE: MARCH 1, 2006 CHECKED BY: TGB

- NOTES:**
- REFER TO PAVEMENT JOINTING AND ELEVATION PLANS FOR DESCRIPTIONS AND DETAILS OF PAVEMENT JOINTS.
 - ANY REQUIRED REGRADE OF EXISTING ADJACENT SUB-BASE GRANULAR MATERIAL SHALL BE INCLUDED IN THE COST OF "SUB-BASE GRANULAR MATERIAL, TYPE B 24"

TYLIN INTERNATIONAL

ADDENDUM 1 05/08/06

05/04/2006 01:59:09 PM

F.A.I. RTE.	SECTION	COUNTY	TOTAL SHEETS	SHEET NO.
94		COOK	764	17
STA. 88+60 (SB I-57) TO STA. 1126+91 (SB FORD) TO STA. 1313+00 (SB RYAN)				
FED. ROAD DIST. NO. ILLINOIS FED. AID PROJECT				
* (1516.1, 1717, & 1818) R-5				

05/04/2006 09:56:40 PM

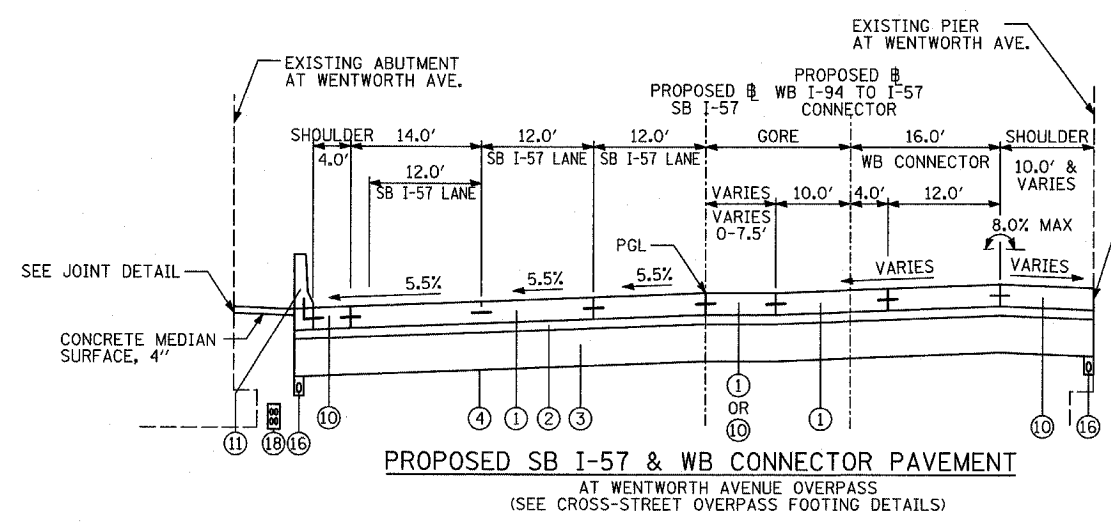
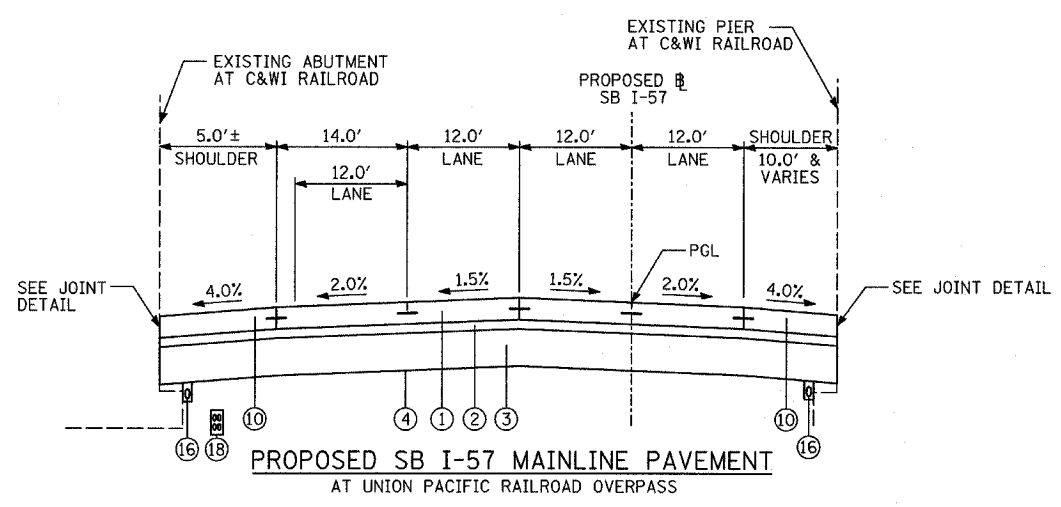

SEE JOINT DETAIL

PROPOSED LEGEND

- ① CONTINUOUSLY REINFORCED PORTLAND CEMENT CONCRETE PAVEMENT 14"; & PAVEMENT REINFORCEMENT, 14"
- ② STABILIZED SUB-BASE, 6" (BITUMINOUS AGGREGATE MIXTURE)
- ③ SUB-BASE GRANULAR MATERIAL, TYPE B 24"
- ④ GEOTECHNICAL FABRIC FOR GROUND STABILIZATION
- ⑤ CONCRETE MEDIAN SURFACE, 6 INCH (SPECIAL)
- ⑥ CONCRETE MEDIAN SURFACE, 6 INCH (SPECIAL) (WITHOUT STAMPED PATTERN)
- ⑦ COMBINATION CONCRETE CURB AND GUTTER, TYPE M-2.24
- ⑧ COMBINATION CONCRETE CURB AND GUTTER, TYPE M-4.24
- ⑨ COMBINATION CONCRETE CURB AND GUTTER, TYPE M-4.48
- ⑩ PORTLAND CEMENT CONCRETE SHOULDERS 14"
- ⑪ CONCRETE BARRIER, SINGLE FACE, 32 INCH HEIGHT; BARRIER BASE; BARRIER WALL MARKERS (PER IDOT STD. 635001 & 635006)
- ⑫ TRAFFIC BARRIER TERMINAL, TYPE VARIES
- ⑬ TOPSOIL FURNISH AND PLACE, 4"; SEEDING, CLASS 2A; EROSION CONTROL BLANKET
- ⑭ AGGREGATE FILL (INCLUDED IN THE COST OF "CONCRETE MEDIAN SURFACE, 6" (SPECIAL)"); (MATCH DEPTH TO ADJACENT CURB & GUTTER)
- ⑮ CONCRETE BARRIER, SINGLE FACE, 42 INCH HEIGHT (SPECIAL); BARRIER BASE; CTA FENCE (SEE DETAILS); BARRIER WALL MARKERS (PER IDOT STD. 635001 & 635006)
- ⑯ PIPE UNDERDRAIN, 6" (SEE DETAILS)
- ⑰ TOPSOIL FURNISH AND PLACE, 12"; COMPOST FURNISH AND PLACE, 6"; EROSION CONTROL BLANKET; SEEDING (SEE PLAN FOR CLASS)
- ⑱ ELECTRICAL DUCTBANK (SEE ELECTRICAL INFRASTRUCTURE PLANS)
- ⑲ CONCRETE BARRIER, SINGLE FACE, 32 INCH HEIGHT (MODIFIED); BARRIER BASE; BARRIER WALL MARKERS (PER IDOT STD. 635001 & 635006)
- ⑳ PORTLAND CEMENT CONCRETE SHOULDERS 9"
- ㉑ 1/2" SHOULDER RESURFACING; BITUMINOUS CONCRETE SURFACE COURSE, SUPERPAVE, MIX "D", N70, 1/2"
- ㉒ 1 3/4" SHOULDER RESURFACING; BITUMINOUS CONCRETE SURFACE COURSE, SUPERPAVE, MIX "D", N70, 1 3/4"
- ㉓ 1 3/4" MAINLINE RESURFACING; POLYMERIZED BITUMINOUS CONCRETE SURFACE COURSE, SUPERPAVE, MIX "F", N105, 1 3/4"
- ㉔ 4" MAINLINE RESURFACING; POLYMERIZED BITUMINOUS CONCRETE SURFACE COURSE, SUPERPAVE, MIX "F", N105, 1 3/4"; POLYMERIZED BITUMINOUS CONCRETE BINDER COURSE, SUPERPAVE, IL-19, N105, 2 1/4"
- ㉕ PORTLAND CEMENT CONCRETE PAVEMENT, 14" (JOINTED)

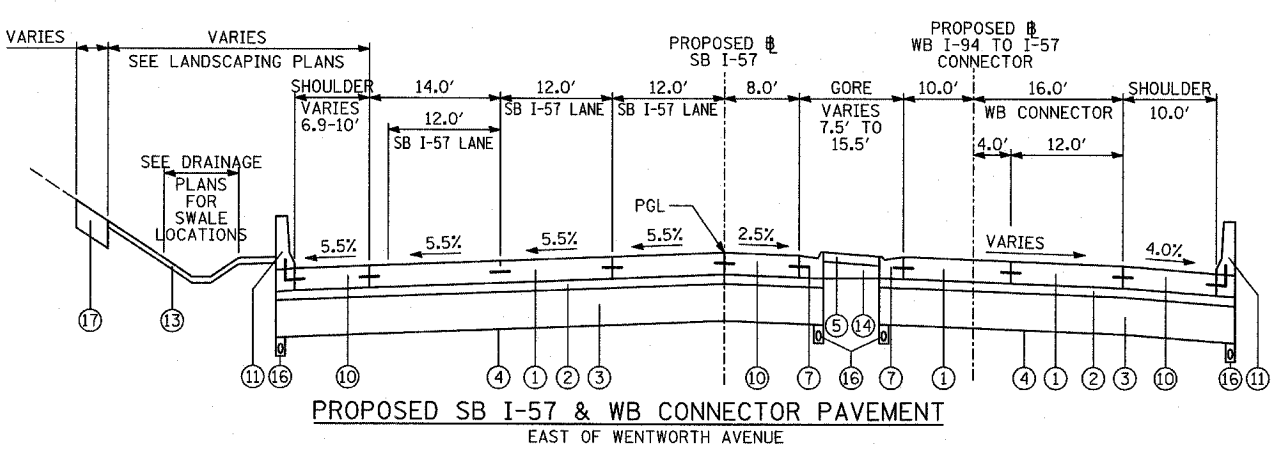
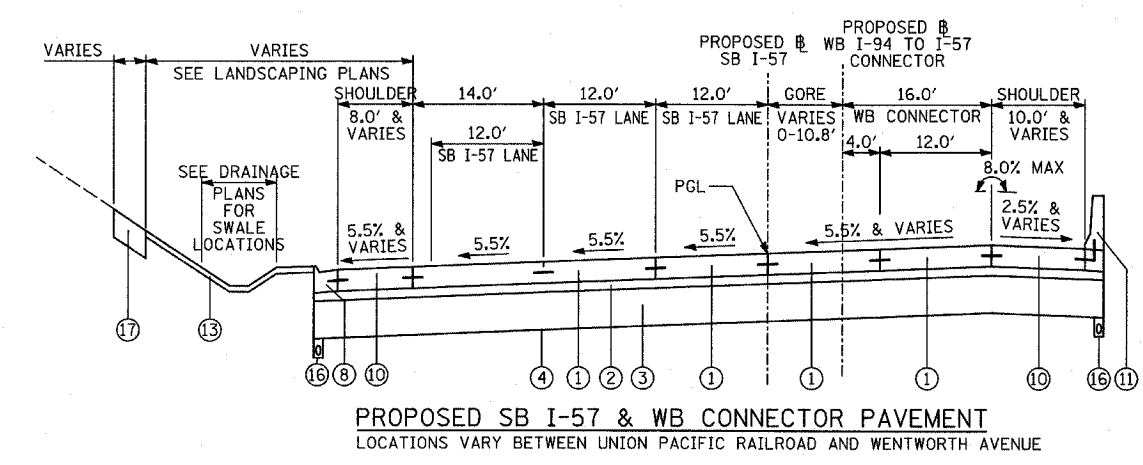
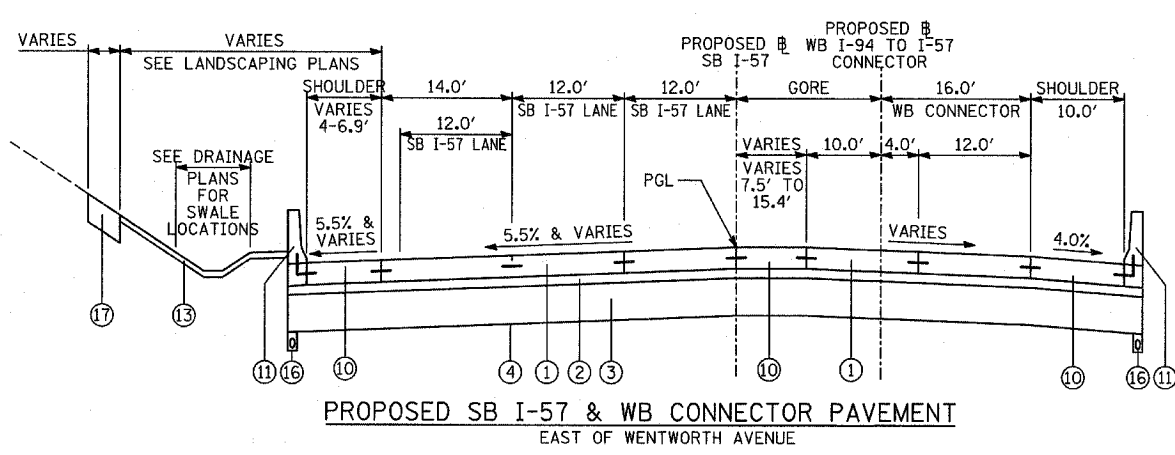
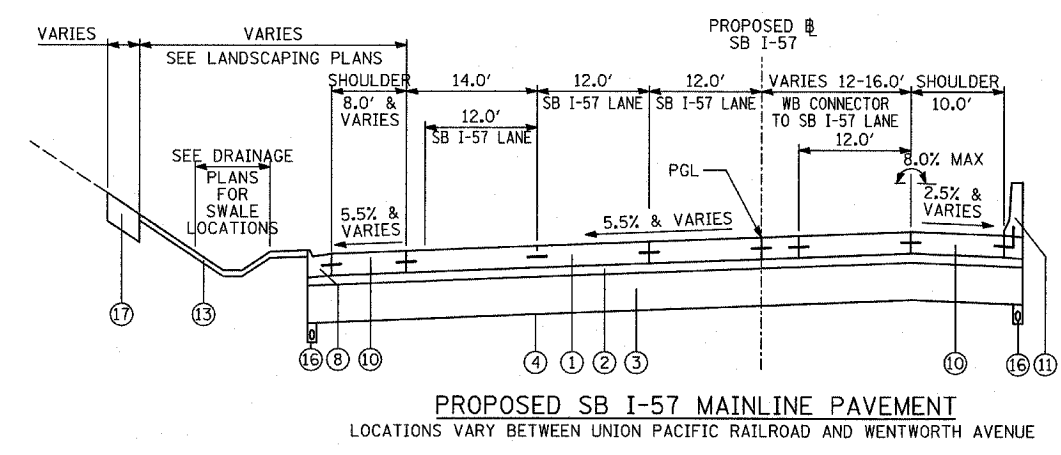

EXISTING LEGEND ALL EXISTING PAVEMENT DEPTHS ARE FROM AS-BUILT PLANS AND ARE SUBJECT TO CHANGE

- (A) BIT CONC SURFACE COURSE, 1/2"±
- (B) BIT CONC BINDER COURSE, 1/2"±
- (C) BIT CONC BINDER COURSE, 3/4"±
- (D) SUB-BASE GRANULAR MATERIAL, 4"±
- (E) SUB-BASE GRANULAR MATERIAL, 6"±
- (F) CRUSHED STONE, 5"± (R) EXISTING PIPE UNDERDRAIN (REMOVAL TO BE PAID FOR SEPARATELY. SEE SPECIAL PROVISION "PIPE UNDERDRAIN REMOVAL")
- (G) PCC SHOULDERS, 9"±
- (H) PCC BASE COURSE, 9"±
- (I) COMB CONC CURB & GUTTER
- (J) PCC PAVEMENT, 10"± (W/ PAVEMENT FABRIC, 80 LBS±/100 SF)
- (K) CONCRETE BARRIER WALL
- (L) PCC SHOULDERS, 11"±
- (M) CTA BALLAST STONE; REGRADE AS NECESSARY (INCLUDE REGRADE IN THE COST OF "CONCRETE BARRIER, SINGLE FACE, 42 INCH HEIGHT (SPECIAL)");
- (N) JOINTED PCC PAVEMENT, 11"±
- (O) STABILIZED SUB-BASE, 4"±
- (P) SUB-BASE GRANULAR MATERIAL, 24"±
- (Q) SUB-BASE GRANULAR MATERIAL, 12"±

NOTES:

1. REFER TO PAVEMENT JOINTING AND ELEVATION PLANS FOR DESCRIPTIONS AND DETAILS OF PAVEMENT JOINTS.

REVISIONS	
NAME	DATE

ILLINOIS DEPARTMENT OF TRANSPORTATION
F.A.I. 94 (DAN RYAN EXPRESSWAY)
PROPOSED TYPICAL SECTIONS
SB I-57 & WB I-94 TO I-57 CONNECTOR
(SHEET 3 OF 8)
SCALE: NONE DRAWN BY: MPG
DATE: MARCH 1, 2006 CHECKED BY: TGB

TYLIN INTERNATIONAL

ADDENDUM 1 05/08/06

F.A.I. RTE.	SECTION	COUNTY	TOTAL SHEETS	SHEET NO.
94	*	COOK	764	18
STA. 88+60 (SB I-57) TO STA. 1126+91 (SB FORD)		TO STA. 1313+00 (SB RYAN)		
FED. ROAD DIST. NO.	ILLINOIS	FED. AID PROJECT		
	(1516, 1, 1717, & 1818) R-5		62593	

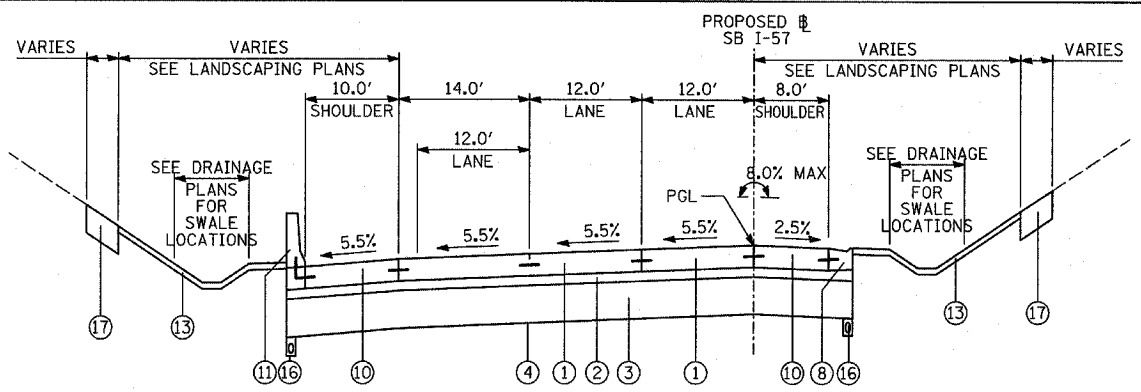

PROPOSED SB I-57 MAINLINE PAVEMENT

LOCATIONS VARY BETWEEN I-57/WB CONNECTOR MERGE AND WENTWORTH AVENUE EXIT RAMP

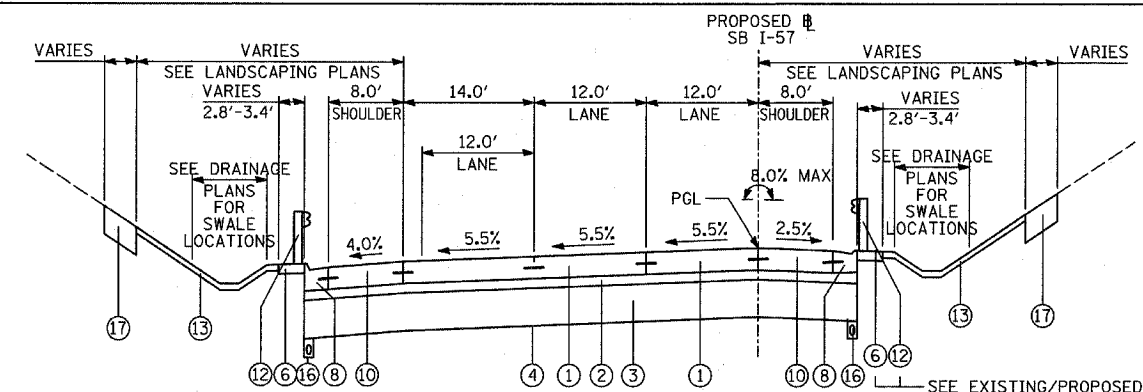

PROPOSED SB I-57 MAINLINE PAVEMENT

LOCATIONS VARY BETWEEN I-57/WB CONNECTOR MERGE AND WENTWORTH AVENUE EXIT RAMP

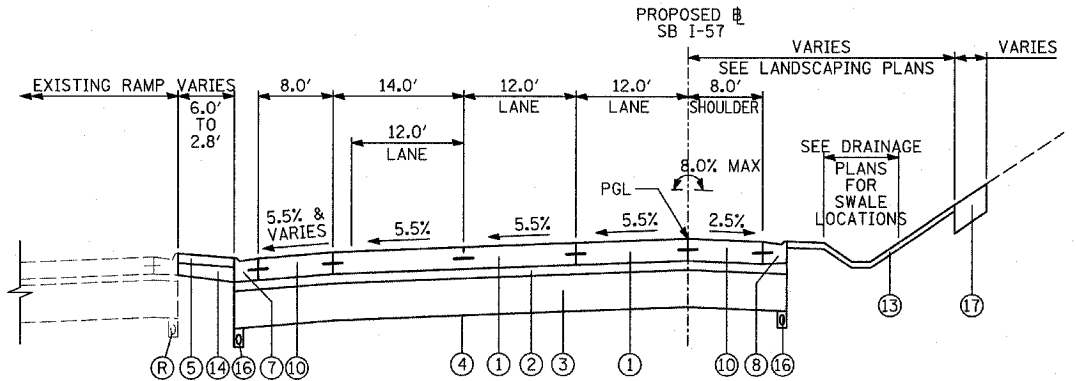

PROPOSED SB I-57 MAINLINE PAVEMENT

WENTWORTH AVENUE EXIT RAMP GORE

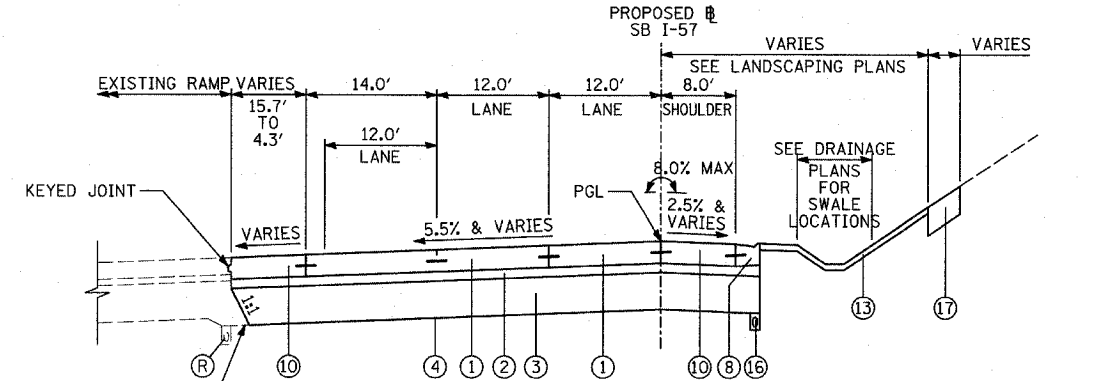

PROPOSED SB I-57 MAINLINE PAVEMENT

WENTWORTH AVENUE EXIT RAMP GORE

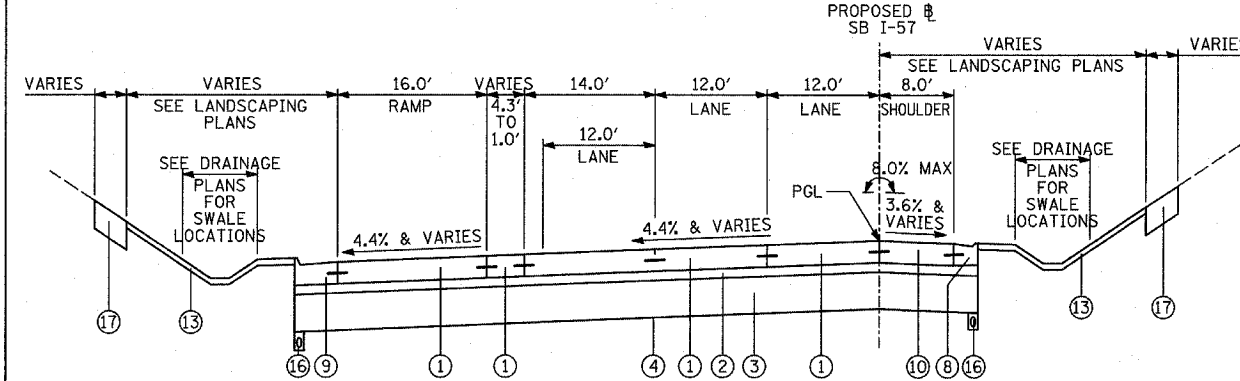

PROPOSED SB I-57 MAINLINE PAVEMENT

WENTWORTH AVENUE EXIT RAMP GORE

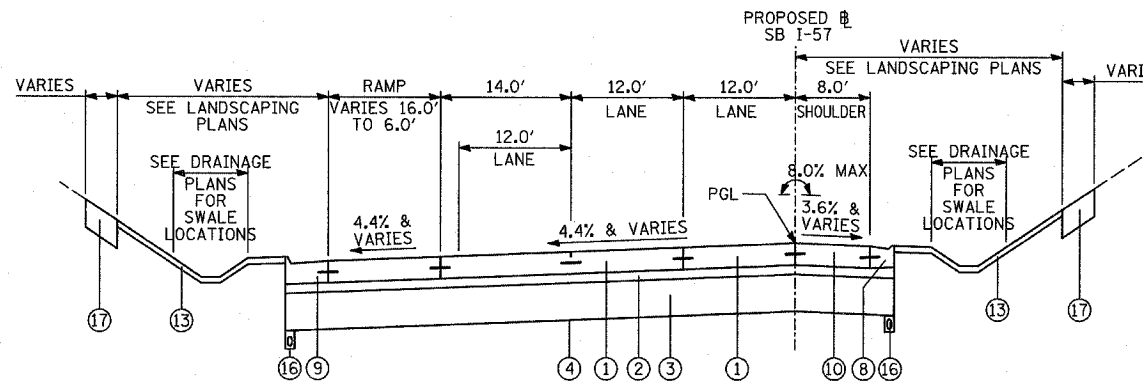

PROPOSED SB I-57 MAINLINE PAVEMENT

WENTWORTH AVENUE EXIT RAMP

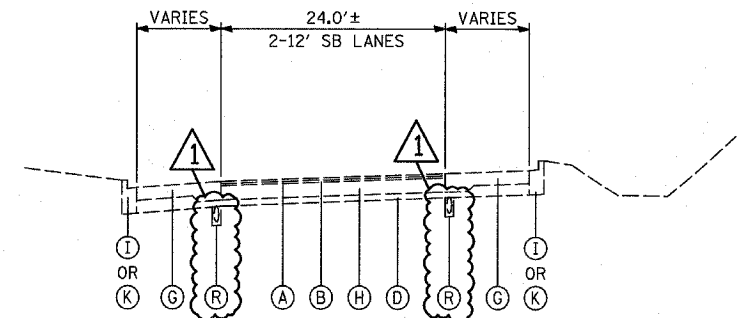

EXISTING SB I-57 MAINLINE PAVEMENT

BETWEEN SB I-57/SB I-94 SPLIT AND I-57/WB CONNECTOR MERGE

- PROPOSED LEGEND**
- CONTINUOUSLY REINFORCED PORTLAND CEMENT CONCRETE PAVEMENT 14" & PAVEMENT REINFORCEMENT, 14"
 - STABILIZED SUB-BASE, 6" (BITUMINOUS AGGREGATE MIXTURE)
 - SUB-BASE GRANULAR MATERIAL, TYPE B 24"
 - GEOTECHNICAL FABRIC FOR GROUND STABILIZATION
 - CONCRETE MEDIAN SURFACE, 6 INCH (SPECIAL)
 - CONCRETE MEDIAN SURFACE, 6 INCH (SPECIAL) (WITHOUT STAMPED PATTERN)
 - COMBINATION CONCRETE CURB AND GUTTER, TYPE M-2.24
 - COMBINATION CONCRETE CURB AND GUTTER, TYPE M-4.24
 - COMBINATION CONCRETE CURB AND GUTTER, TYPE M-4.48
 - PORTLAND CEMENT CONCRETE SHOULDERS 14"
 - CONCRETE BARRIER, SINGLE FACE, 32 INCH HEIGHT; BARRIER BASE; BARRIER WALL MARKERS (PER IDOT STD. 635001 & 635006)
 - TRAFFIC BARRIER TERMINAL, TYPE VARIES
 - TOPSOIL FURNISH AND PLACE, 4"; SEEDING, CLASS 2A; EROSION CONTROL BLANKET
 - AGGREGATE FILL (INCLUDED IN THE COST OF "CONCRETE MEDIAN SURFACE, 6" (SPECIAL) (MATCH DEPTH TO ADJACENT CURB & GUTTER)
 - CONCRETE BARRIER, SINGLE FACE, 42 INCH HEIGHT (SPECIAL); BARRIER BASE; CTA FENCE (SEE DETAILS); BARRIER WALL MARKERS (PER IDOT STD. 635001 & 635006)
 - PIPE UNDERDRAIN, 6" (SEE DETAILS)
 - TOPSOIL FURNISH AND PLACE, 12"; COMPOST FURNISH AND PLACE, 6"; EROSION CONTROL BLANKET; SEEDING (SEE PLAN FOR CLASS)
 - ELECTRICAL DUCTBANK (SEE ELECTRICAL INFRASTRUCTURE PLANS)
 - CONCRETE BARRIER, SINGLE FACE, 32 INCH HEIGHT (MODIFIED); BARRIER BASE; BARRIER WALL MARKERS (PER IDOT STD. 635001 & 635006)
 - PORTLAND CEMENT CONCRETE SHOULDERS 9"
 - 1/2" SHOULDER RESURFACING: BITUMINOUS CONCRETE SURFACE COURSE, SUPERPAVE, MIX "D", N70, 1/2"
 - 1 3/4" SHOULDER RESURFACING: BITUMINOUS CONCRETE SURFACE COURSE, SUPERPAVE, MIX "D", N70, 1 3/4"
 - 1 3/4" MAINLINE RESURFACING: POLYMERIZED BITUMINOUS CONCRETE SURFACE COURSE, SUPERPAVE, MIX "F", N105, 1 3/4"
 - 4" MAINLINE RESURFACING: POLYMERIZED BITUMINOUS CONCRETE SURFACE COURSE, SUPERPAVE, MIX "F", N105, 1 3/4"; POLYMERIZED BITUMINOUS CONCRETE BINDER COURSE, SUPERPAVE, IL-19, N105, 2 1/4"
 - PORTLAND CEMENT CONCRETE PAVEMENT, 14" (JOINTED)
- EXISTING LEGEND** ALL EXISTING PAVEMENT DEPTHS ARE FROM AS-BUILT PLANS AND ARE SUBJECT TO CHANGE
- BIT CONC SURFACE COURSE, 1/2"±
 - BIT CONC BINDER COURSE, 1/2"±
 - BIT CONC BINDER COURSE, 4 3/4"±
 - SUB-BASE GRANULAR MATERIAL, 4"±
 - SUB-BASE GRANULAR MATERIAL, 6"±
 - CRUSHED STONE, 5"± (EXISTING PIPE UNDERDRAIN (REMOVAL TO BE PAID FOR SEPARATELY. SEE SPECIAL PROVISION "PIPE UNDERDRAIN REMOVAL")
 - PCC SHOULDERS, 9"±
 - PCC BASE COURSE, 9"±
 - COMB CONC CURB & GUTTER
 - PCC PAVEMENT, 10"± (W/ PAVEMENT FABRIC, 80 LBS±/100 SF)
 - CONCRETE BARRIER WALL
 - PCC SHOULDERS, 11"±
 - CTA BALLAST STONE: REGRADE AS NECESSARY (INCLUDE REGRADING IN THE COST OF "CONCRETE BARRIER, SINGLE FACE, 42 INCH HEIGHT (SPECIAL)")
 - JOINTED PCC PAVEMENT, 11"±
 - STABILIZED SUB-BASE, 4"±
 - SUB-BASE GRANULAR MATERIAL, 24"±
 - SUB-BASE GRANULAR MATERIAL, 12"±

NOTES:

- REFER TO PAVEMENT JOINTING AND ELEVATION PLANS FOR DESCRIPTIONS AND DETAILS OF PAVEMENT JOINTS.
- ANY REQUIRED REGRADING OF EXISTING ADJACENT SUB-BASE GRANULAR MATERIAL SHALL BE INCLUDED IN THE COST OF "SUB-BASE GRANULAR MATERIAL, TYPE B 24"

REVISIONS	
NAME	DATE

ILLINOIS DEPARTMENT OF TRANSPORTATION
F.A.I. 94 (DAN RYAN EXPRESSWAY)
**EXISTING & PROPOSED TYPICAL SECTIONS
 SB I-57
 (SHEET 4 OF 8)**

SCALE: NONE
 DATE: MARCH 1, 2006
 DRAWN BY: MPG
 CHECKED BY: TGB

ADDENDUM 1 05/08/06

F.A.I. RTE.	SECTION	COUNTY	TOTAL SHEETS	SHEET NO.
94		COOK	764	19
88+60 (SB I-57) STA. 1126+91 (SB FORD) TO STA. 1313+00 (SB RYAN)				
FED. ROAD DIST. NO.	ILLINOIS	FED. AID PROJECT		
(1516.1, 1717, & 1818) R-5			62593	

- PROPOSED LEGEND**
- ① CONTINUOUSLY REINFORCED PORTLAND CEMENT CONCRETE PAVEMENT 14"; & PAVEMENT REINFORCEMENT, 14"
 - ② STABILIZED SUB-BASE, 6" (BITUMINOUS AGGREGATE MIXTURE)
 - ③ SUB-BASE GRANULAR MATERIAL, TYPE B 24"
 - ④ GEOTECHNICAL FABRIC FOR GROUND STABILIZATION
 - ⑤ CONCRETE MEDIAN SURFACE, 6 INCH (SPECIAL)
 - ⑥ CONCRETE MEDIAN SURFACE, 6 INCH (SPECIAL) (WITHOUT STAMPED PATTERN)
 - ⑦ COMBINATION CONCRETE CURB AND GUTTER, TYPE M-2.24
 - ⑧ COMBINATION CONCRETE CURB AND GUTTER, TYPE M-4.24
 - ⑨ COMBINATION CONCRETE CURB AND GUTTER, TYPE M-4.48
 - ⑩ PORTLAND CEMENT CONCRETE SHOULDERS 14"
 - ⑪ CONCRETE BARRIER, SINGLE FACE, 32 INCH HEIGHT; BARRIER BASE; BARRIER WALL MARKERS (PER IDOT STD. 635001 & 635006)
 - ⑫ TRAFFIC BARRIER TERMINAL, TYPE VARIES
 - ⑬ TOPSOIL FURNISH AND PLACE, 4"; SEEDING, CLASS 2A; EROSION CONTROL BLANKET
 - ⑭ AGGREGATE FILL (INCLUDED IN THE COST OF "CONCRETE MEDIAN SURFACE, 6" (SPECIAL)"; MATCH DEPTH TO ADJACENT CURB & GUTTER)
 - ⑮ CONCRETE BARRIER, SINGLE FACE, 42 INCH HEIGHT (SPECIAL); BARRIER BASE; CTA FENCE (SEE DETAILS); BARRIER WALL MARKERS (PER IDOT STD. 635001 & 635006)
 - ⑯ PIPE UNDERDRAIN, 6" (SEE DETAILS)
 - ⑰ TOPSOIL FURNISH AND PLACE, 12"; COMPOST FURNISH AND PLACE, 6"; EROSION CONTROL BLANKET; SEEDING (SEE PLAN FOR CLASS)
 - ⑱ ELECTRICAL DUCTBANK (SEE ELECTRICAL INFRASTRUCTURE PLANS)
 - ⑲ CONCRETE BARRIER, SINGLE FACE, 32 INCH HEIGHT (MODIFIED); BARRIER BASE; BARRIER WALL MARKERS (PER IDOT STD. 635001 & 635006)
 - ⑳ PORTLAND CEMENT CONCRETE SHOULDERS 9"
 - ㉑ 1/2" SHOULDER RESURFACING; BITUMINOUS CONCRETE SURFACE COURSE, SUPERPAVE, MIX "D", N70, 1/2"
 - ㉒ 1 1/4" SHOULDER RESURFACING; BITUMINOUS CONCRETE SURFACE COURSE, SUPERPAVE, MIX "D", N70, 1 1/4"
 - ㉓ 1 1/4" MAINLINE RESURFACING; POLYMERIZED BITUMINOUS CONCRETE SURFACE COURSE, SUPERPAVE, MIX "F", N105, 1 1/4"
 - ㉔ 4" MAINLINE RESURFACING; POLYMERIZED BITUMINOUS CONCRETE SURFACE COURSE, SUPERPAVE, MIX "F", N105, 1 1/4"; POLYMERIZED BITUMINOUS CONCRETE BINDER COURSE, SUPERPAVE, IL-19, N105, 2 1/4"
 - ㉕ PORTLAND CEMENT CONCRETE PAVEMENT, 14" (JOINTED)

- EXISTING LEGEND** ALL EXISTING PAVEMENT DEPTHS ARE FROM AS-BUILT PLANS AND ARE SUBJECT TO CHANGE
- (A) BIT CONC SURFACE COURSE, 1/2"±
 - (B) BIT CONC BINDER COURSE, 1/2"±
 - (C) BIT CONC BINDER COURSE, 3/4"±
 - (D) SUB-BASE GRANULAR MATERIAL, 4"±
 - (E) SUB-BASE GRANULAR MATERIAL, 6"±
 - (F) CRUSHED STONE, 5"±
 - (R) EXISTING PIPE UNDERDRAIN (REMOVAL TO BE PAID FOR SEPARATELY. SEE SPECIAL PROVISION "PIPE UNDERDRAIN REMOVAL")
 - (G) PCC SHOULDERS, 9"±
 - (H) PCC BASE COURSE, 9"±
 - (I) COMB CONC CURB & GUTTER
 - (J) PCC PAVEMENT, 10"± (W/ PAVEMENT FABRIC, 80 LBS±/100 SF)
 - (K) CONCRETE BARRIER WALL
 - (L) PCC SHOULDERS, 11"±
 - (M) CTA BALLAST STONE; REGRADE AS NECESSARY (INCLUDE REGRADE IN THE COST OF "CONCRETE BARRIER, SINGLE FACE, 42 INCH HEIGHT (SPECIAL)";)
 - (N) JOINTED PCC PAVEMENT, 11"±
 - (O) STABILIZED SUB-BASE, 4"±
 - (P) SUB-BASE GRANULAR MATERIAL, 24"±
 - (Q) SUB-BASE GRANULAR MATERIAL, 12"±

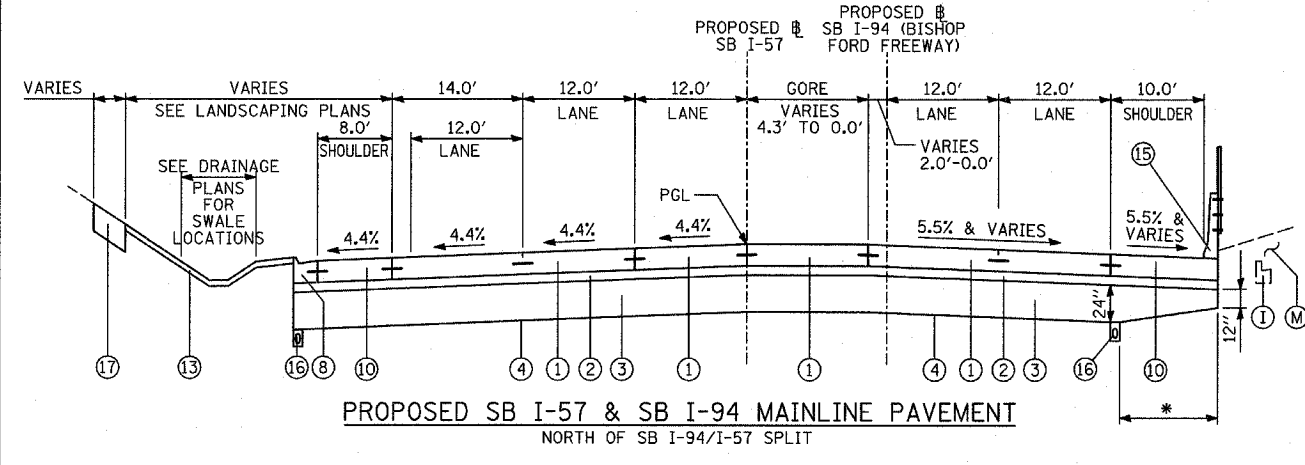
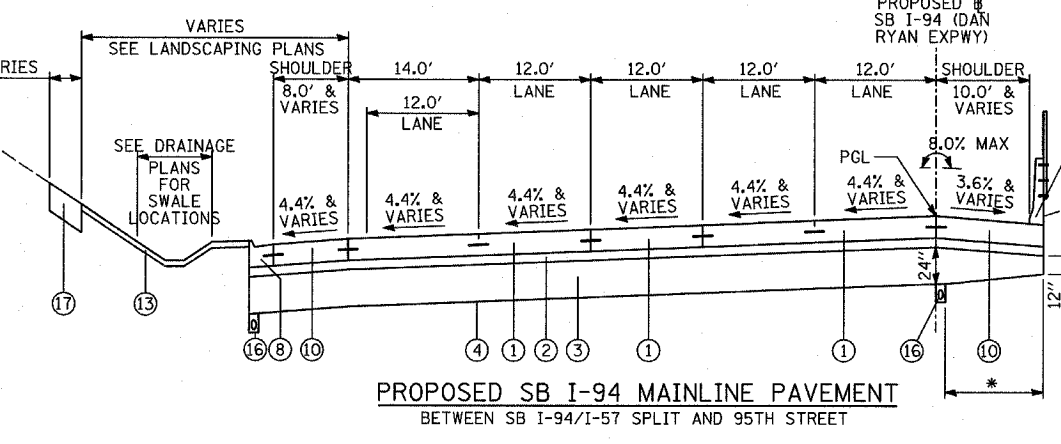
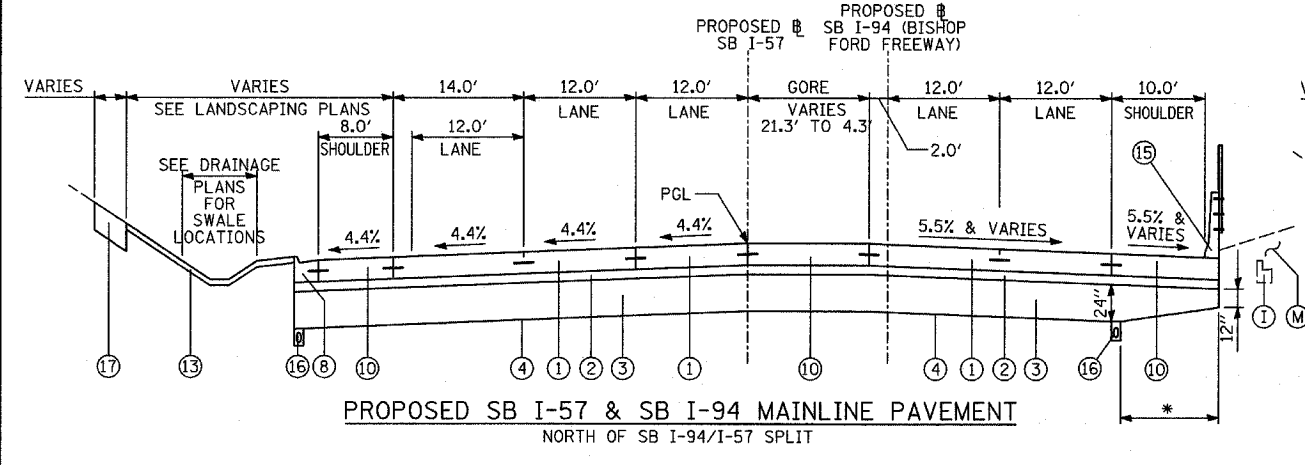
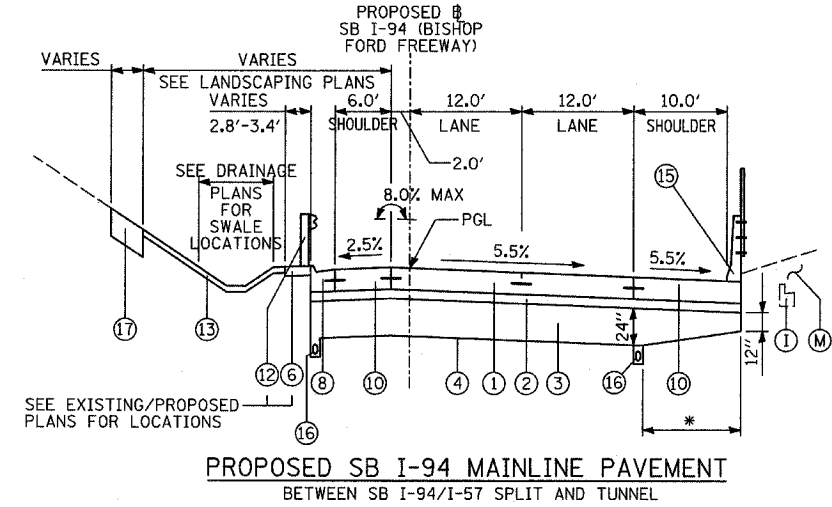
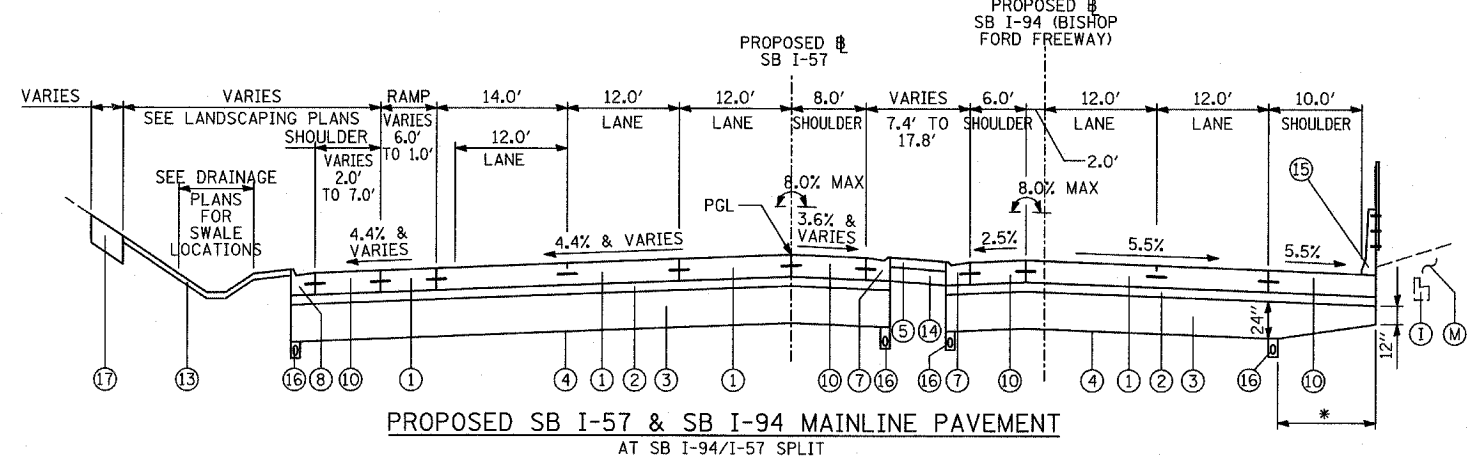

NOTES:

1. REFER TO PAVEMENT JOINTING AND ELEVATION PLANS FOR DESCRIPTIONS AND DETAILS OF PAVEMENT JOINTS.

* - VARYING DEPTH PAID FOR AS "SUB-BASE GRANULAR MATERIAL, TYPE B 24"

REVISIONS	
NAME	DATE
ADDENDUM 1	05/08/06

ILLINOIS DEPARTMENT OF TRANSPORTATION
F.A.I. 94 (DAN RYAN EXPRESSWAY)

PROPOSED TYPICAL SECTIONS
SB I-57 & SB I-94 (BISHOP FORD FREEWAY AND DAN RYAN EXPRESSWAY)
(SHEET 5 OF 8)

SCALE: NONE
 DATE: MARCH 1, 2006
 DRAWN BY: MPG
 CHECKED BY: TGB

F.A.I. RTE.	SECTION	COUNTY	TOTAL SHEETS	SHEET NO.
94	*	COOK	764	20
STA. 1126+91 (SB FORD) TO STA. 1313+00 (SB RYAN)				
FED. ROAD DIST. NO.	ILLINOIS	FED. AID PROJECT		
(1516.1, 1717, & 1818) R-5			62593	

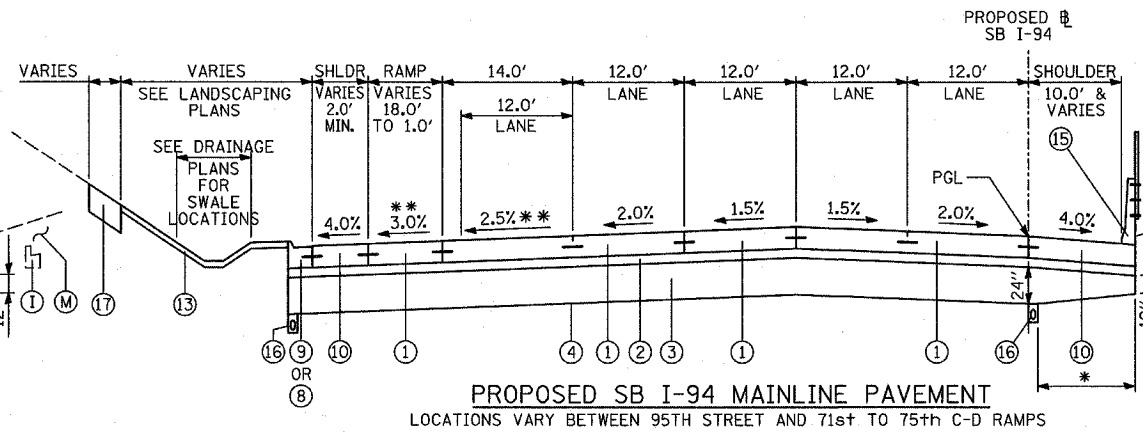
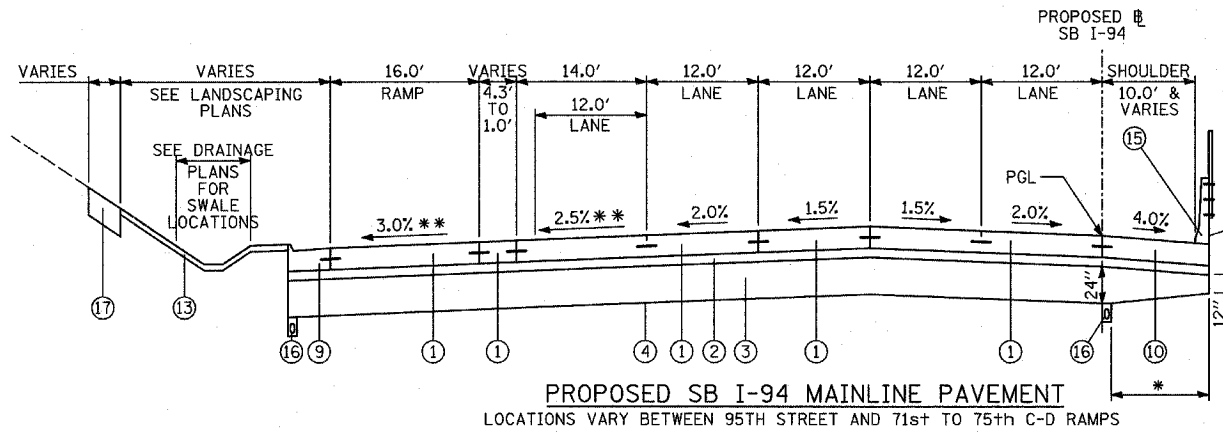
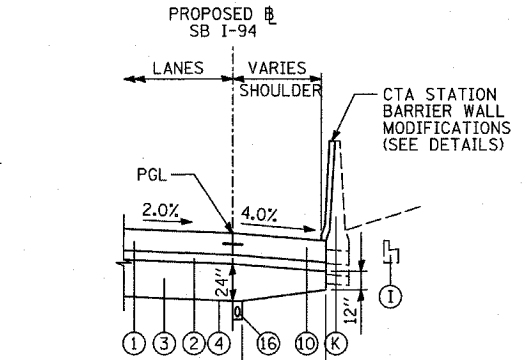
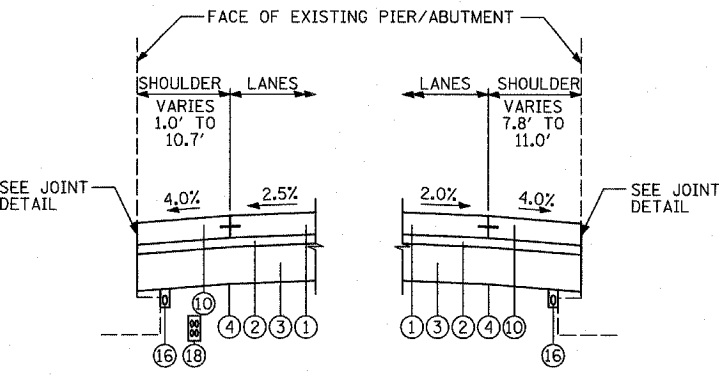
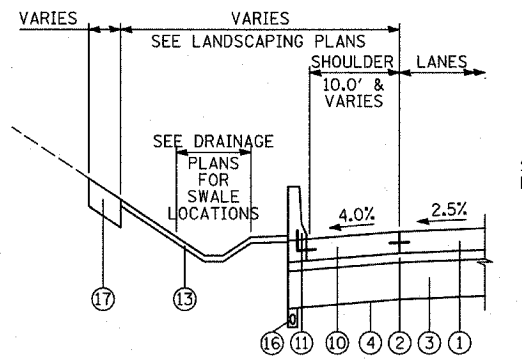
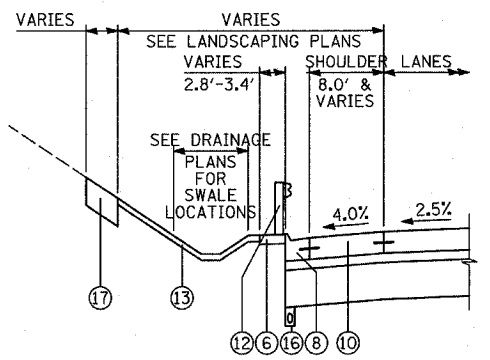
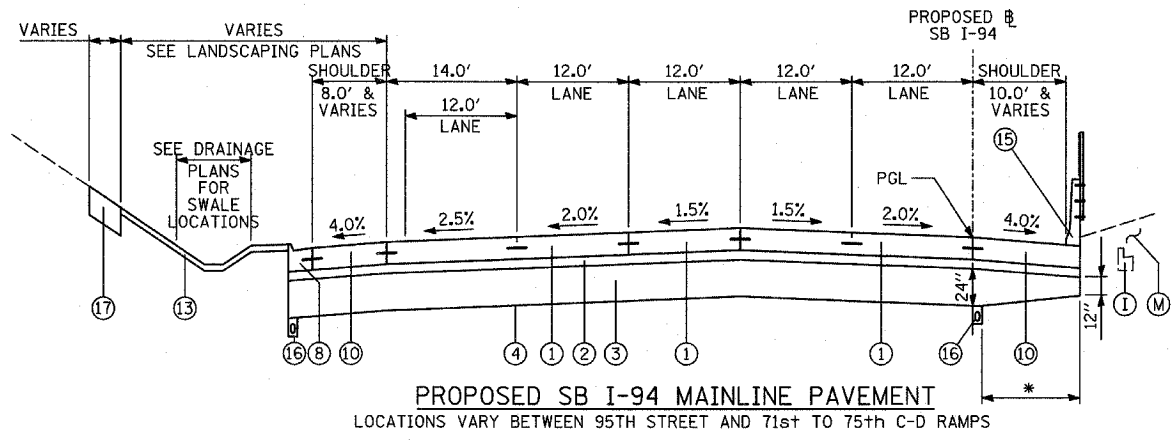
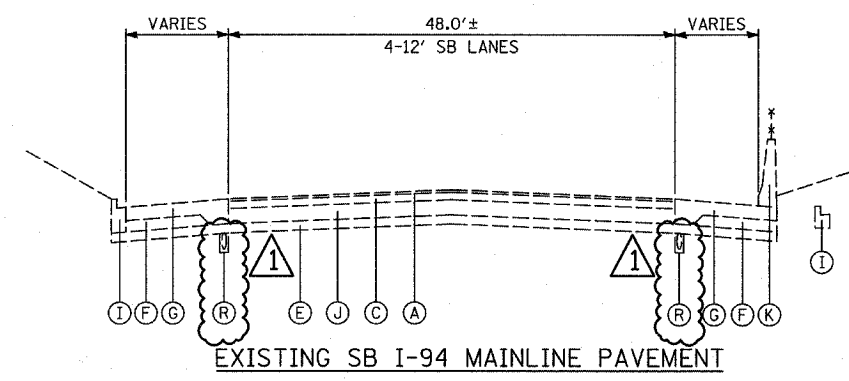

- ### PROPOSED LEGEND
- ① CONTINUOUSLY REINFORCED PORTLAND CEMENT CONCRETE PAVEMENT 14"; & PAVEMENT REINFORCEMENT, 14"
 - ② STABILIZED SUB-BASE, 6" (BITUMINOUS AGGREGATE MIXTURE)
 - ③ SUB-BASE GRANULAR MATERIAL, TYPE B 24"
 - ④ GEOTECHNICAL FABRIC FOR GROUND STABILIZATION
 - ⑤ CONCRETE MEDIAN SURFACE, 6 INCH (SPECIAL)
 - ⑥ CONCRETE MEDIAN SURFACE, 6 INCH (SPECIAL) (WITHOUT STAMPED PATTERN)
 - ⑦ COMBINATION CONCRETE CURB AND GUTTER, TYPE M-2.24
 - ⑧ COMBINATION CONCRETE CURB AND GUTTER, TYPE M-4.24
 - ⑨ COMBINATION CONCRETE CURB AND GUTTER, TYPE M-4.48
 - ⑩ PORTLAND CEMENT CONCRETE SHOULDERS 14"
 - ⑪ CONCRETE BARRIER, SINGLE FACE, 32 INCH HEIGHT; BARRIER BASE; BARRIER WALL MARKERS (PER IDOT STD. 635001 & 635006)
 - ⑫ TRAFFIC BARRIER TERMINAL, TYPE VARIES
 - ⑬ TOPSOIL FURNISH AND PLACE, 4"; SEEDING, CLASS 2A; EROSION CONTROL BLANKET
 - ⑭ AGGREGATE FILL (INCLUDED IN THE COST OF "CONCRETE MEDIAN SURFACE, 6" (SPECIAL)") (MATCH DEPTH TO ADJACENT CURB & GUTTER)
 - ⑮ CONCRETE BARRIER, SINGLE FACE, 42 INCH HEIGHT (SPECIAL); BARRIER BASE; CTA FENCE (SEE DETAILS); BARRIER WALL MARKERS (PER IDOT STD. 635001 & 635006)
 - ⑯ PIPE UNDERDRAIN, 6" (SEE DETAILS)
 - ⑰ TOPSOIL FURNISH AND PLACE, 12"; COMPOST FURNISH AND PLACE, 6"; EROSION CONTROL BLANKET; SEEDING (SEE PLAN FOR CLASS)
 - ⑱ ELECTRICAL DUCTBANK (SEE ELECTRICAL INFRASTRUCTURE PLANS)
 - ⑲ CONCRETE BARRIER, SINGLE FACE, 32 INCH HEIGHT (MODIFIED); BARRIER BASE; BARRIER WALL MARKERS (PER IDOT STD. 635001 & 635006)
 - ⑳ PORTLAND CEMENT CONCRETE SHOULDERS 9"
 - ㉑ 1/2" SHOULDER RESURFACING: BITUMINOUS CONCRETE SURFACE COURSE, SUPERPAVE, MIX "D", N70, 1/2"
 - ㉒ 3/4" SHOULDER RESURFACING: BITUMINOUS CONCRETE SURFACE COURSE, SUPERPAVE, MIX "D", N70, 3/4"
 - ㉓ 1 3/4" MAINLINE RESURFACING: POLYMERIZED BITUMINOUS CONCRETE SURFACE COURSE, SUPERPAVE, MIX "F", N105, 1 3/4"
 - ㉔ 4" MAINLINE RESURFACING: POLYMERIZED BITUMINOUS CONCRETE SURFACE COURSE, SUPERPAVE, MIX "F", N105, 1 3/4"; POLYMERIZED BITUMINOUS CONCRETE BINDER COURSE, SUPERPAVE, IL-19, N105, 2 1/4"
 - ㉕ PORTLAND CEMENT CONCRETE PAVEMENT, 14" (JOINTED)
- ### EXISTING LEGEND
- ALL EXISTING PAVEMENT DEPTHS ARE FROM AS-BUILT PLANS AND ARE SUBJECT TO CHANGE
- (A) BIT CONC SURFACE COURSE, 1/2"±
 - (B) BIT CONC BINDER COURSE, 1/2"±
 - (C) BIT CONC BINDER COURSE, 3/4"±
 - (D) SUB-BASE GRANULAR MATERIAL, 4"±
 - (E) SUB-BASE GRANULAR MATERIAL, 6"±
 - (F) CRUSHED STONE, 5"±
 - (G) PCC SHOULDERS, 9"±
 - (H) PCC BASE COURSE, 9"±
 - (I) COMB CONC CURB & GUTTER
 - (J) PCC PAVEMENT, 10"± (W/ PAVEMENT FABRIC, 80 LBS±/100 SF)
 - (K) CONCRETE BARRIER WALL
 - (L) PCC SHOULDERS, 11"±
 - (M) CTA BALLAST STONE; REGRADE AS NECESSARY (INCLUDE REGRADE IN THE COST OF "CONCRETE BARRIER, SINGLE FACE, 42 INCH HEIGHT (SPECIAL)")
 - (N) JOINTED PCC PAVEMENT, 11"±
 - (O) STABILIZED SUB-BASE, 4"±
 - (P) SUB-BASE GRANULAR MATERIAL, 24"±
 - (Q) SUB-BASE GRANULAR MATERIAL, 12"±

NOTES:

1. REFER TO PAVEMENT JOINTING AND ELEVATION PLANS FOR DESCRIPTIONS AND DETAILS OF PAVEMENT JOINTS.
- *- VARYING DEPTH PAID FOR AS "SUB-BASE GRANULAR MATERIAL, TYPE B 24"
- ** - CROSS-SLOPES VARY AT 87TH STREET ENTRANCE RAMP

REVISIONS		ILLINOIS DEPARTMENT OF TRANSPORTATION	
NAME	DATE	F.A.I. 94 (DAN RYAN EXPRESSWAY)	
		EXISTING & PROPOSED TYPICAL SECTIONS	
		SB I-94 (DAN RYAN EXPRESSWAY)	
		(SHEET 6 OF 8)	
		SCALE: NONE	DRAWN BY: MPG
		DATE: MARCH 1, 2006	CHECKED BY: TGB
ADDENDUM 1	05/08/06		

F.A.I. RTE.	SECTION	COUNTY	TOTAL SHEETS	SHEET NO.
94		COOK	764	21
STA. 88+60 (SB I-57) TO STA. 1126+91 (SB FORD) TO STA. 1313+00 (SB RYAN)				
FED. ROAD DIST. NO. ILLINOIS FED. AID PROJECT				
• (1516.1, 1717, & 1818) R-5				
				62593

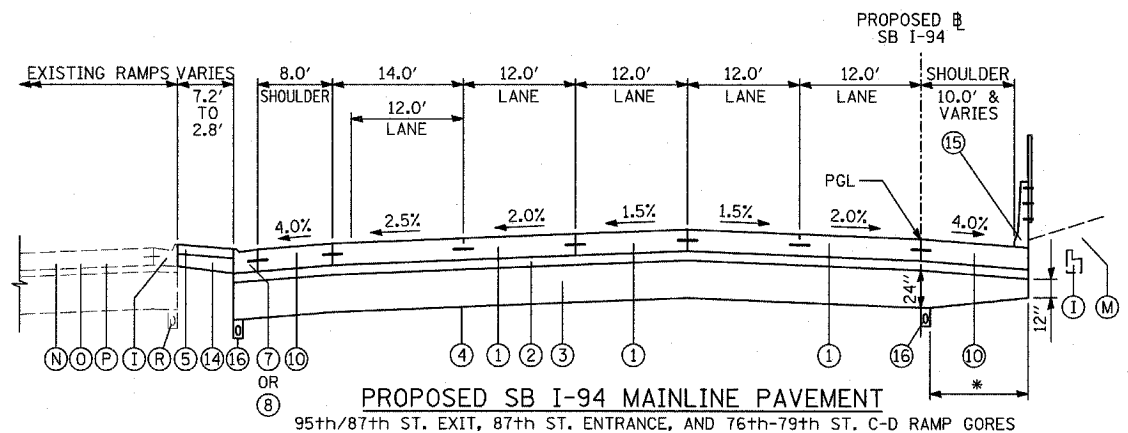
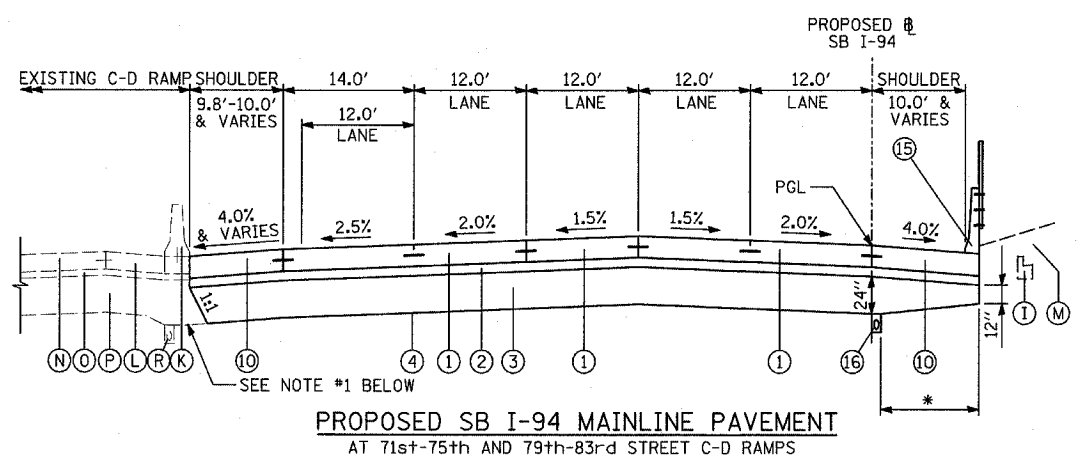
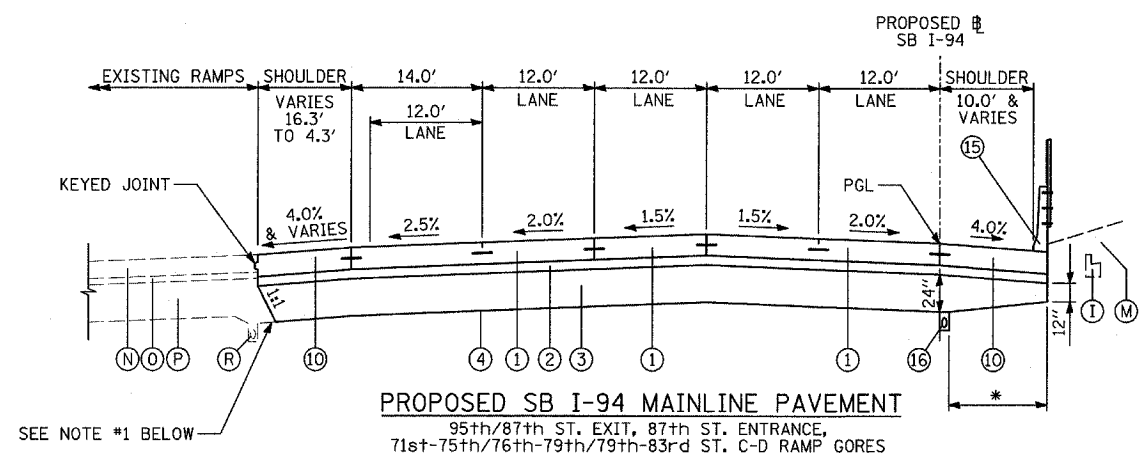

PROPOSED LEGEND

- ① CONTINUOUSLY REINFORCED PORTLAND CEMENT CONCRETE PAVEMENT 14"; & PAVEMENT REINFORCEMENT, 14"
- ② STABILIZED SUB-BASE, 6" (BITUMINOUS AGGREGATE MIXTURE)
- ③ SUB-BASE GRANULAR MATERIAL, TYPE B 24"
- ④ GEOTECHNICAL FABRIC FOR GROUND STABILIZATION
- ⑤ CONCRETE MEDIAN SURFACE, 6 INCH (SPECIAL)
- ⑥ CONCRETE MEDIAN SURFACE, 6 INCH (SPECIAL) (WITHOUT STAMPED PATTERN)
- ⑦ COMBINATION CONCRETE CURB AND GUTTER, TYPE M-2.24
- ⑧ COMBINATION CONCRETE CURB AND GUTTER, TYPE M-4.24
- ⑨ COMBINATION CONCRETE CURB AND GUTTER, TYPE M-4.48
- ⑩ PORTLAND CEMENT CONCRETE SHOULDERS 14"
- ⑪ CONCRETE BARRIER, SINGLE FACE, 32 INCH HEIGHT; BARRIER BASE; BARRIER WALL MARKERS (PER IDOT STD. 635001 & 635006)
- ⑫ TRAFFIC BARRIER TERMINAL, TYPE VARIES
- ⑬ TOPSOIL FURNISH AND PLACE, 4"; SEEDING, CLASS 2A; EROSION CONTROL BLANKET
- ⑭ AGGREGATE FILL (INCLUDED IN THE COST OF "CONCRETE MEDIAN SURFACE, 6" (SPECIAL)"); MATCH DEPTH TO ADJACENT CURB & GUTTER
- ⑮ CONCRETE BARRIER, SINGLE FACE, 42 INCH HEIGHT (SPECIAL); BARRIER BASE; CTA FENCE (SEE DETAILS); BARRIER WALL MARKERS (PER IDOT STD. 635001 & 635006)
- ⑯ PIPE UNDERDRAIN, 6" (SEE DETAILS)
- ⑰ TOPSOIL FURNISH AND PLACE, 12"; COMPOST FURNISH AND PLACE, 6"; EROSION CONTROL BLANKET; SEEDING (SEE PLAN FOR CLASS)
- ⑱ ELECTRICAL DUCTBANK (SEE ELECTRICAL INFRASTRUCTURE PLANS)
- ⑲ CONCRETE BARRIER, SINGLE FACE, 32 INCH HEIGHT (MODIFIED); BARRIER BASE; BARRIER WALL MARKERS (PER IDOT STD. 635001 & 635006)
- ⑳ PORTLAND CEMENT CONCRETE SHOULDERS 9"
- ㉑ 1/2" SHOULDER RESURFACING; BITUMINOUS CONCRETE SURFACE COURSE, SUPERPAVE, MIX "D", N70, 1/2"
- ㉒ 1 3/4" SHOULDER RESURFACING; BITUMINOUS CONCRETE SURFACE COURSE, SUPERPAVE, MIX "D", N70, 1 3/4"
- ㉓ 1 3/4" MAINLINE RESURFACING; POLYMERIZED BITUMINOUS CONCRETE SURFACE COURSE, SUPERPAVE, MIX "F", N105, 1 3/4"
- ㉔ 4" MAINLINE RESURFACING; POLYMERIZED BITUMINOUS CONCRETE SURFACE COURSE, SUPERPAVE, MIX "F", N105, 1 3/4"; POLYMERIZED BITUMINOUS CONCRETE BINDER COURSE, SUPERPAVE, IL-19, N105, 2 1/4"
- ㉕ PORTLAND CEMENT CONCRETE PAVEMENT, 14" (JOINTED)

EXISTING LEGEND ALL EXISTING PAVEMENT DEPTHS ARE FROM AS-BUILT PLANS AND ARE SUBJECT TO CHANGE

- Ⓐ BIT CONC SURFACE COURSE, 1 1/2"±
- Ⓑ BIT CONC BINDER COURSE, 1 1/2"±
- Ⓒ BIT CONC BINDER COURSE, 4 3/4"±
- Ⓓ SUB-BASE GRANULAR MATERIAL, 4"±
- Ⓔ SUB-BASE GRANULAR MATERIAL, 6"±
- Ⓕ CRUSHED STONE, 5"± (R) EXISTING PIPE UNDERDRAIN (REMOVAL TO BE PAID FOR SEPARATELY. SEE SPECIAL PROVISION "PIPE UNDERDRAIN REMOVAL")
- Ⓖ PCC SHOULDERS, 9"±
- Ⓗ PCC BASE COURSE, 9"±
- Ⓘ COMB CONC CURB & GUTTER
- Ⓧ PCC PAVEMENT, 10"± (W/ PAVEMENT FABRIC, 80 LBS±/100 SF)
- Ⓚ CONCRETE BARRIER WALL
- Ⓛ PCC SHOULDERS, 11"±
- Ⓜ CTA BALLAST STONE; REGRADE AS NECESSARY (INCLUDE REGADING IN THE COST OF "CONCRETE BARRIER, SINGLE FACE, 42 INCH HEIGHT (SPECIAL)")
- Ⓝ JOINTED PCC PAVEMENT, 11"±
- Ⓞ STABILIZED SUB-BASE, 4"±
- Ⓟ SUB-BASE GRANULAR MATERIAL, 24"±
- Ⓠ SUB-BASE GRANULAR MATERIAL, 12"±

NOTES:

1. REFER TO PAVEMENT JOINTING AND ELEVATION PLANS FOR DESCRIPTIONS AND DETAILS OF PAVEMENT JOINTS.
 2. ANY REQUIRED REGRADING OF EXISTING ADJACENT SUB-BASE GRANULAR MATERIAL SHALL BE INCLUDED IN THE COST OF "SUB-BASE GRANULAR MATERIAL, TYPE B 24"
- * - VARYING DEPTH PAID FOR AS "SUB-BASE GRANULAR MATERIAL, TYPE B 24"

REVISIONS	
NAME	DATE

ILLINOIS DEPARTMENT OF TRANSPORTATION
 F.A.I. 94 (DAN RYAN EXPRESSWAY)

**PROPOSED TYPICAL SECTIONS
 SB I-94 (DAN RYAN EXPRESSWAY)
 (SHEET 7 OF 8)**

SCALE: NONE DRAWN BY: MPG
 DATE: MARCH 1, 2006 CHECKED BY: TCB

TYLIN INTERNATIONAL

05/04/2006 01:56:12 PM

F.A.I. RTE.	SECTION	COUNTY	TOTAL SHEETS	SHEET NO.
94		COOK	764	22
STA. 88+60 (SB I-57) TO STA. 1313+00 (SB RYAN)				
FED. ROAD DIST. NO. ILLINOIS FED. AID PROJECT				
(1516.1, 1717, & 1818) R-5				

01/50/16 PM
05/08/2006

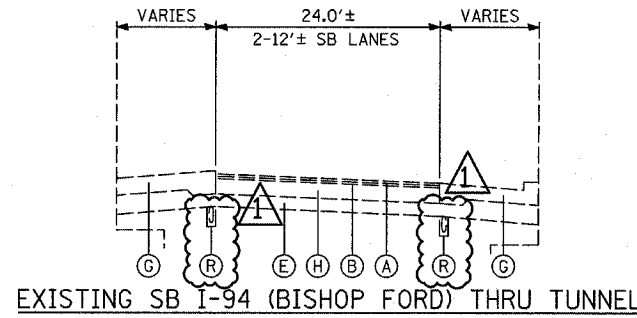

EXISTING SB I-94 (BISHOP FORD) THRU TUNNEL

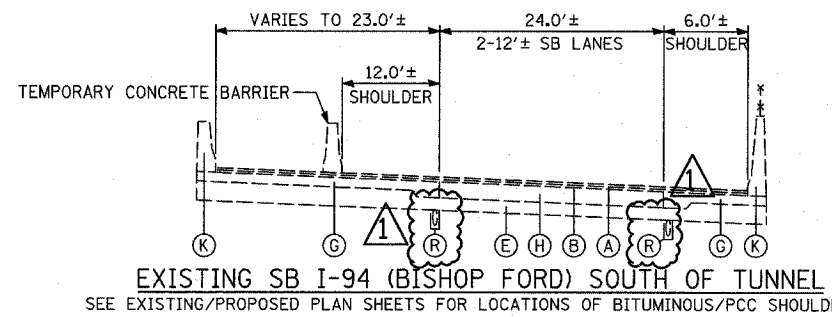

EXISTING SB I-94 (BISHOP FORD) SOUTH OF TUNNEL
SEE EXISTING/PROPOSED PLAN SHEETS FOR LOCATIONS OF BITUMINOUS/PCC SHOULDERS

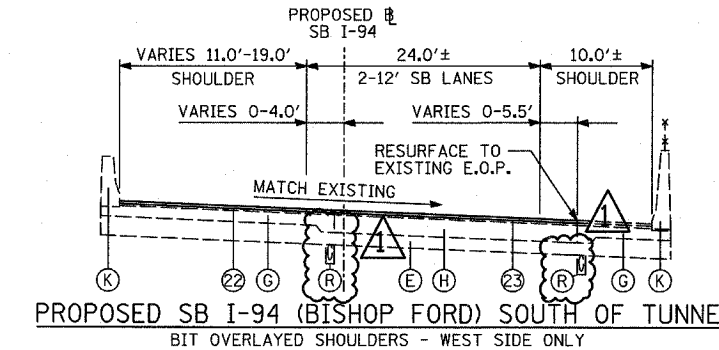

PROPOSED SB I-94 (BISHOP FORD) SOUTH OF TUNNEL
BIT OVERLAYED SHOULDERS - WEST SIDE ONLY

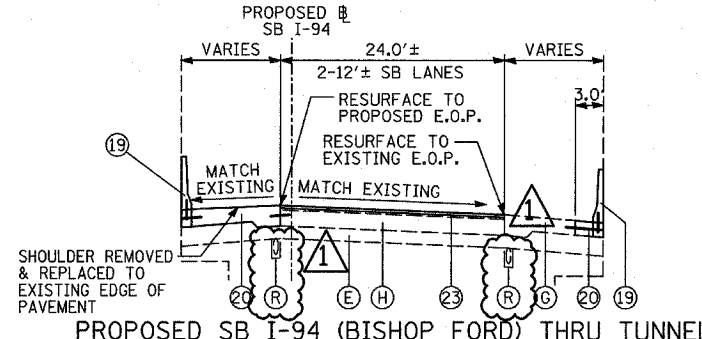

PROPOSED SB I-94 (BISHOP FORD) THRU TUNNEL

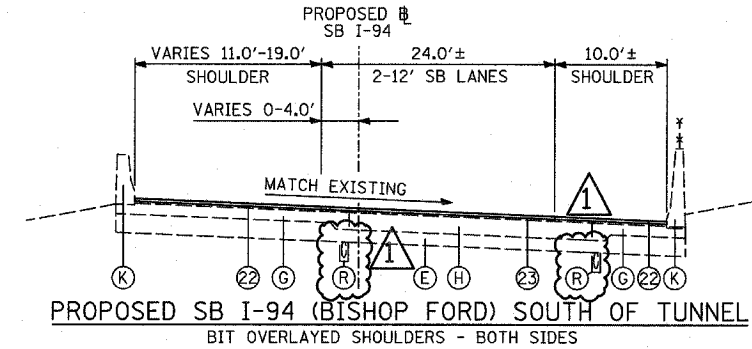

PROPOSED SB I-94 (BISHOP FORD) SOUTH OF TUNNEL
BIT OVERLAYED SHOULDERS - BOTH SIDES

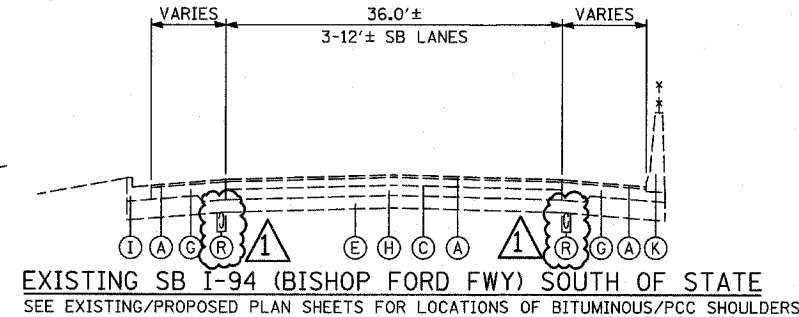

EXISTING SB I-94 (BISHOP FORD FWY) SOUTH OF STATE
SEE EXISTING/PROPOSED PLAN SHEETS FOR LOCATIONS OF BITUMINOUS/PCC SHOULDERS

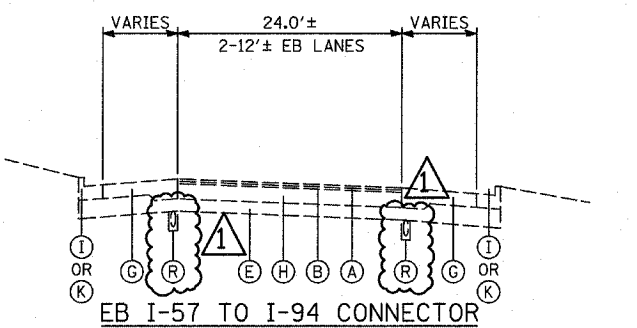

EB I-57 TO I-94 CONNECTOR

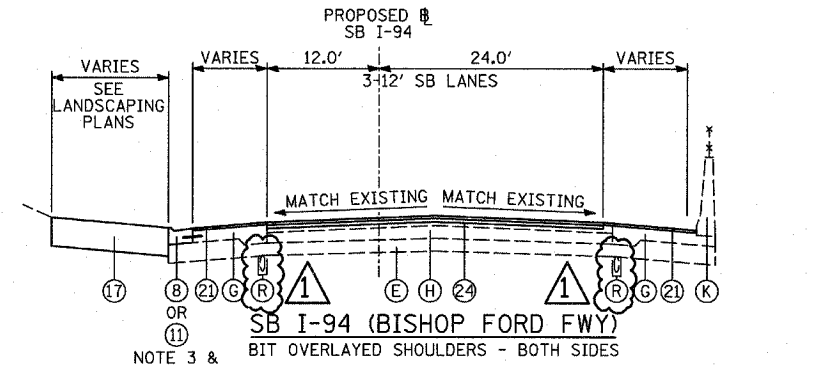

SB I-94 (BISHOP FORD FWY)
BIT OVERLAYED SHOULDERS - BOTH SIDES

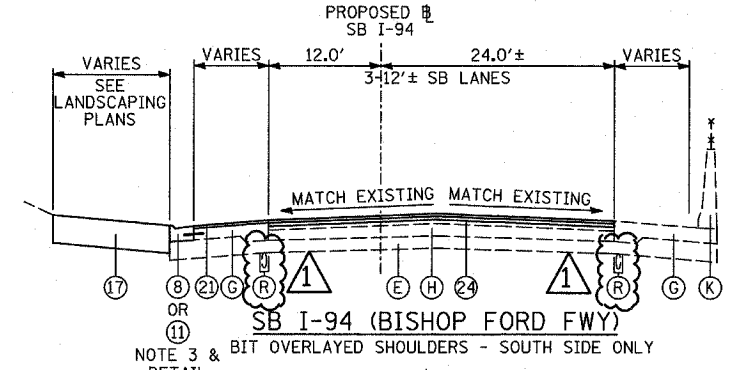

PROPOSED SB I-94 (BISHOP FORD FWY)
BIT OVERLAYED SHOULDERS - SOUTH SIDE ONLY

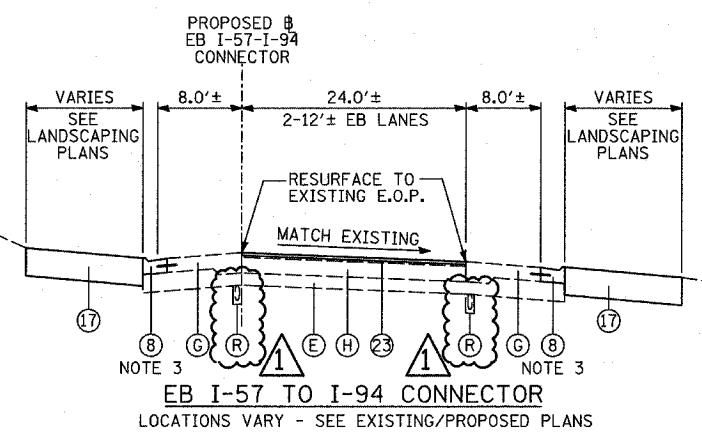

EB I-57 TO I-94 CONNECTOR
LOCATIONS VARY - SEE EXISTING/PROPOSED PLANS

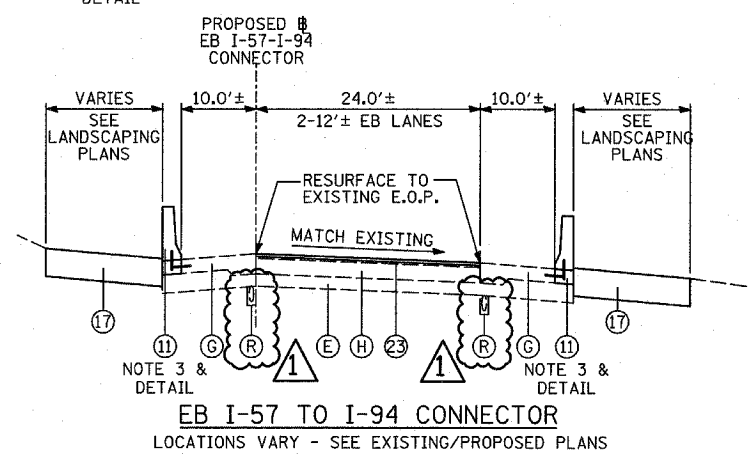

EB I-57 TO I-94 CONNECTOR
LOCATIONS VARY - SEE EXISTING/PROPOSED PLANS

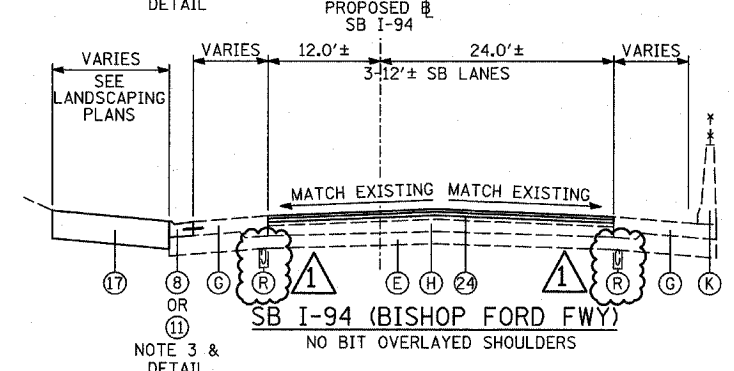

SB I-94 (BISHOP FORD FWY)
NO BIT OVERLAYED SHOULDERS

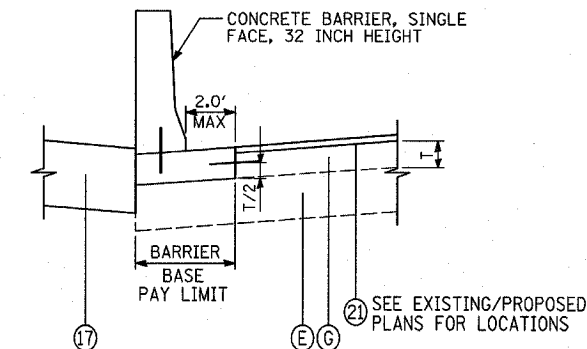

DETAIL OF EXTENDED BARRIER BASE
IF NECESSARY - FIELD CONDITIONS WILL DICTATE NEED

- PROPOSED LEGEND**
- CONTINUOUSLY REINFORCED PORTLAND CEMENT CONCRETE PAVEMENT 14" & PAVEMENT REINFORCEMENT, 14"
 - STABILIZED SUB-BASE, 6" (BITUMINOUS AGGREGATE MIXTURE)
 - SUB-BASE GRANULAR MATERIAL, TYPE B 24"
 - GEOTECHNICAL FABRIC FOR GROUND STABILIZATION
 - CONCRETE MEDIAN SURFACE, 6 INCH (SPECIAL)
 - CONCRETE MEDIAN SURFACE, 6 INCH (SPECIAL) (WITHOUT STAMPED PATTERN)
 - COMBINATION CONCRETE CURB AND GUTTER, TYPE M-2.24
 - COMBINATION CONCRETE CURB AND GUTTER, TYPE M-4.24
 - COMBINATION CONCRETE CURB AND GUTTER, TYPE M-4.48
 - PORTLAND CEMENT CONCRETE SHOULDERS 14"
 - CONCRETE BARRIER, SINGLE FACE, 32 INCH HEIGHT; BARRIER BASE; BARRIER WALL MARKERS (PER IDOT STD. 635001 & 635006)
 - TRAFFIC BARRIER TERMINAL, TYPE VARIES
 - TOPSOIL FURNISH AND PLACE, 4"; SEEDING, CLASS 2A; EROSION CONTROL BLANKET
 - AGGREGATE FILL (INCLUDED IN THE COST OF "CONCRETE MEDIAN SURFACE, 6" (SPECIAL) (MATCH DEPTH TO ADJACENT CURB & GUTTER)
 - CONCRETE BARRIER, SINGLE FACE, 42 INCH HEIGHT (SPECIAL); BARRIER BASE; CTA FENCE (SEE DETAILS); BARRIER WALL MARKERS (PER IDOT STD. 635001 & 635006)
 - PIPE UNDERDRAIN, 6" (SEE DETAILS)
 - TOPSOIL FURNISH AND PLACE, 12"; COMPOST FURNISH AND PLACE, 6"; EROSION CONTROL BLANKET; SEEDING (SEE PLAN FOR CLASS)
 - ELECTRICAL DUCTBANK (SEE ELECTRICAL INFRASTRUCTURE PLANS)
 - CONCRETE BARRIER, SINGLE FACE, 32 INCH HEIGHT (MODIFIED); BARRIER BASE; BARRIER WALL MARKERS (PER IDOT STD. 635001 & 635006)
 - PORTLAND CEMENT CONCRETE SHOULDERS 9"
 - 1/2" SHOULDER RESURFACING: BITUMINOUS CONCRETE SURFACE COURSE, SUPERPAVE, MIX "D", N70, 1/2"
 - 1 3/4" SHOULDER RESURFACING: BITUMINOUS CONCRETE SURFACE COURSE, SUPERPAVE, MIX "D", N70, 1 3/4"
 - 1 3/4" MAINLINE RESURFACING: POLYMERIZED BITUMINOUS CONCRETE SURFACE COURSE, SUPERPAVE, MIX "F", N105, 1 3/4"
 - 4" MAINLINE RESURFACING: POLYMERIZED BITUMINOUS CONCRETE SURFACE COURSE, SUPERPAVE, MIX "F", N105, 1 3/4"; POLYMERIZED BITUMINOUS CONCRETE BINDER COURSE, SUPERPAVE, IL-19, N105, 2 1/4"
 - PORTLAND CEMENT CONCRETE PAVEMENT, 14" (JOINTED)

- EXISTING LEGEND** ALL EXISTING PAVEMENT DEPTHS ARE FROM AS-BUILT PLANS AND ARE SUBJECT TO CHANGE
- BIT CONC SURFACE COURSE, 1/2"±
 - BIT CONC BINDER COURSE, 1/2"±
 - BIT CONC BINDER COURSE, 4 3/4"±
 - SUB-BASE GRANULAR MATERIAL, 4"±
 - SUB-BASE GRANULAR MATERIAL, 6"±
 - CRUSHED STONE, 5"± (EXISTING PIPE UNDERDRAIN (REMOVAL TO BE PAID FOR SEPARATELY. SEE SPECIAL PROVISION "PIPE UNDERDRAIN REMOVAL")
 - PCC SHOULDERS, 9"±
 - PCC BASE COURSE, 9"±
 - COMB CONC CURB & GUTTER
 - PCC PAVEMENT, 10"± (W/ PAVEMENT FABRIC, 80 LBS±/100 SF)
 - CONCRETE BARRIER WALL
 - PCC SHOULDERS, 11"±
 - CTA BALLAST STONE; REGRADE AS NECESSARY (INCLUDE REGRADING IN THE COST OF "CONCRETE BARRIER, SINGLE FACE, 42 INCH HEIGHT (SPECIAL)")
 - JOINTED PCC PAVEMENT, 11"±
 - STABILIZED SUB-BASE, 4"±
 - SUB-BASE GRANULAR MATERIAL, 24"±
 - SUB-BASE GRANULAR MATERIAL, 12"±

- NOTES:**
- REFER TO PAVEMENT JOINTING AND ELEVATION PLANS FOR DESCRIPTIONS AND DETAILS OF PAVEMENT JOINTS.
 - ANY REQUIRED REGRADING OF EXISTING ADJACENT SUB-BASE GRANULAR MATERIAL SHALL BE INCLUDED IN THE COST OF "SUB-BASE GRANULAR MATERIAL, TYPE B 24"
 - PROPOSED CURB OR BARRIER BASE SHALL BE PLACED ON EXISTING SUBGRADE WITH THICKNESS EQUAL TO EXISTING ADJACENT PCC SHOULDERS. RECOMPACTING OF EXISTING SUBGRADE OR PLACEMENT OF ADDITIONAL AGGREGATE SHALL BE INCLUDED IN THE COST OF "COMBINATION CONCRETE CURB AND GUTTER, TYPE M-4.24, OR "CONCRETE BARRIER, SINGLE FACE", OF THE TYPE SPECIFIED.

REVISIONS		ILLINOIS DEPARTMENT OF TRANSPORTATION	
NAME	DATE	F.A.I. 94 (DAN RYAN EXPRESSWAY)	
		EXISTING & PROPOSED TYPICAL SECTIONS INTERCHANGE AREA (SHEET 8 OF 8)	
		SCALE: NONE	DRAWN BY: MFG
		DATE: MARCH 1, 2006	CHECKED BY: TGB
		ADDENDUM 1	05/08/06

TYLIN INTERNATIONAL

TREE REMOVAL (6 TO 15 UNITS)

ALIGNMENT	LOCATION				TREE REMOV 6-15 (UNIT)
	STATION	OFFSET	NORTHING	EASTING	
SB I-57	91+05.2	52.4 LT	1839469.4	1172789.1	6
SB I-57	91+25.1	59.2 LT	1839476.7	1172808.9	10
SB I-57	91+69.7	69.8 LT	1839488.4	1172853.2	6
SB I-57	107+32.9	51.6 LT	1839508.5	1174416.4	13
SB I-57	117+05.2	81.0 LT	1839561.8	1175387.7	12
SB I-57	117+34.7	89.5 LT	1839571.0	1175417.0	8
SB I-57	117+60.2	83.9 LT	1839566.1	1175442.6	14
SB I-57	118+54.2	61.1 LT	1839545.6	1175537.1	10
SB I-57	118+84.4	90.1 LT	1839575.3	1175566.6	8
SB I-57	119+07.4	82.2 LT	1839568.0	1175589.8	9
SB I-57	119+27.1	70.7 LT	1839556.9	1175609.7	10
SB I-57	119+29.4	80.4 LT	1839566.7	1175611.9	8
SB I-57	119+57.8	69.3 LT	1839556.3	1175640.4	6
SB I-57	119+62.5	93.5 LT	1839580.6	1175644.6	12
SB I-57	119+82.1	96.9 LT	1839584.5	1175664.1	14
SB I-57	120+23.1	84.2 LT	1839572.8	1175705.4	6
SB I-57	120+30.2	89.0 LT	1839577.8	1175712.3	12
SB I-57	120+77.5	56.4 LT	1839546.4	1175760.5	12
SB I-57	120+77.5	56.4 LT	1839546.4	1175760.5	6
SB I-57	120+77.5	56.4 LT	1839546.4	1175760.5	8
SB I-57	121+14.6	77.8 LT	1839568.7	1175797.0	9
SB I-57	124+01.9	65.6 LT	1839580.8	1176074.2	11
SB I-57	129+72.9	66.8 LT	1839751.8	1176595.7	13
SB I-57	129+97.7	90.2 LT	1839783.5	1176606.3	14
SB I-57	130+15.8	75.5 LT	1839778.4	1176628.4	7
SB I-57	130+19.8	80.6 LT	1839781.8	1176629.4	9
SB I-57	133+51.5	40.0 LT	1839926.3	1176920.0	6
SB I-57	133+81.9	40.2 LT	1839945.0	1176943.1	8
SB I-57	133+91.8	40.1 LT	1839951.1	1176950.7	7
SB I-57	151+48.5	84.5 LT	1841468.2	1177641.3	10
SB I-57	153+20.1	97.8 LT	1841634.8	1177640.7	10
SB I-57	153+20.2	108.3 LT	1841635.4	1177630.2	10
SB I-57	153+20.9	106.1 LT	1841636.0	1177632.4	10
SB I-57	153+26.7	106.7 LT	1841641.6	1177632.1	10
SB I-57	153+53.1	91.7 LT	1841666.5	1177648.1	10
SB I-57	153+55.9	95.2 LT	1841669.3	1177644.6	10
SB I-57	153+60.2	96.6 LT	1841673.5	1177643.4	10
SB I-57	153+63.0	92.8 LT	1841676.1	1177647.3	10
SB I-94(FORD)	1154+78.6	47.7 LT	1839541.7	1178020.6	9
SB I-94(RYAN)	1237+36.8	81.1 LT	1845117.2	1177589.5	14
SB I-94(RYAN)	1237+49.9	77.2 LT	1845130.4	1177593.1	10
SB I-94(RYAN)	1259+71.6	99.8 LT	1847350.6	1177506.8	7
SB I-94(RYAN)	1259+72.2	81.2 LT	1847351.7	1177525.4	14
SB I-94(RYAN)	1259+90.6	104.7 LT	1847369.4	1177501.5	13
SB I-94(RYAN)	1261+00.6	103.4 LT	1847479.4	1177499.5	8
SB I-94(RYAN)	1261+07.5	111.5 LT	1847486.1	1177491.3	10
SB I-94(RYAN)	1261+10.7	105.7 LT	1847489.4	1177497.0	10
SB I-94(RYAN)	1261+17.9	111.8 LT	1847496.4	1177490.7	8
SB I-94(RYAN)	1261+20.4	103.9 LT	1847499.2	1177498.5	7
SB I-94(RYAN)	1261+22.7	111.6 LT	1847501.2	1177490.7	12
SB I-94(RYAN)	1261+27.7	110.8 LT	1847506.2	1177491.4	8
SB I-94(RYAN)	1261+30.8	107.2 LT	1847509.5	1177494.9	6
SB I-94(RYAN)	1261+37.9	110.6 LT	1847516.5	1177491.3	7

(CONT. ABOVE)

TREE REMOVAL (6 TO 15 UNITS) (CONT. FROM BELOW)

ALIGNMENT	LOCATION				TREE REMOV 6-15 (UNIT)
	STATION	OFFSET	NORTHING	EASTING	
SB I-94(RYAN)	1261+48.2	103.9 LT	1847527.0	1177497.7	8
SB I-94(RYAN)	1261+59.8	111.6 LT	1847538.4	1177489.7	6
SB I-94(RYAN)	1261+60.4	97.0 LT	1847539.3	1177504.3	12
SB I-94(RYAN)	1261+71.9	95.7 LT	1847550.8	1177505.2	12
SB I-94(RYAN)	1283+74.7	113.6 LT	1849752.3	1177424.3	6
SB I-94(RYAN)	1283+82.6	123.4 LT	1849759.9	1177414.3	10
SB I-94(RYAN)	1283+90.7	121.3 LT	1849768.1	1177416.1	9
SB I-94(RYAN)	1283+94.6	115.9 LT	1849772.0	1177421.4	7
SB I-94(RYAN)	1283+97.9	105.0 LT	1849775.7	1177432.2	15
SB I-94(RYAN)	1284+05.9	111.6 LT	1849783.5	1177425.4	6
SB I-94(RYAN)	1284+06.3	97.6 LT	1849784.3	1177439.3	10
SB I-94(RYAN)	1284+35.6	115.0 LT	1849813.1	1177421.2	12
SB I-94(RYAN)	1284+35.6	115.0 LT	1849813.1	1177421.2	9
SB I-94(RYAN)	1284+76.5	92.8 LT	1849854.6	1177442.2	12
SB I-94(RYAN)	1284+86.5	122.3 LT	1849863.7	1177412.4	6
SB I-94(RYAN)	1284+94.4	122.0 LT	1849871.6	1177412.5	10
SB I-94(RYAN)	1285+09.9	87.3 LT	1849888.2	1177446.7	14
SB I-94(RYAN)	1285+22.5	83.0 LT	1849900.9	1177450.7	6
SB I-94(RYAN)	1285+30.6	112.8 LT	1849908.1	1177420.6	6
SB I-94(RYAN)	1285+30.6	81.2 LT	1849909.0	1177452.2	14
SB I-94(RYAN)	1285+35.4	111.3 LT	1849913.0	1177422.0	14
SB I-94(RYAN)	1286+52.6	103.7 LT	1850030.3	1177426.2	6
SB I-94(RYAN)	1286+61.1	104.8 LT	1850038.8	1177424.9	6
SB I-94(RYAN)	1286+69.7	95.3 LT	1850047.7	1177434.1	14
SB I-94(RYAN)	1286+71.5	108.0 LT	1850049.0	1177421.4	7
SB I-94(RYAN)	1287+44.5	110.0 LT	1850122.0	1177417.3	8
SB I-94(RYAN)	1288+18.1	118.1 LT	1850195.3	1177407.1	14
SB I-94(RYAN)	1288+29.2	118.8 LT	1850206.5	1177406.1	6
SB I-94(RYAN)	1288+31.7	118.7 LT	1850209.0	1177406.2	6
TOTAL (6-15 UNITS)					784

TREE REMOVAL (OVER 15 UNITS)

ALIGNMENT	LOCATION				TREE REMOV OVER 15 (UNIT)
	STATION	OFFSET	NORTHING	EASTING	
SB I-57	119+23.9	89.1 LT	1839575.3	1175606.1	18
SB I-57	120+31.7	81.9 LT	1839570.7	1175714.0	18
SB I-57	130+26.2	95.2 LT	1839800.6	1176627.8	26
SB I-94(RYAN)	1259+82.7	89.2 LT	1847362.0	1177517.1	16
SB I-94(RYAN)	1284+52.6	109.7 LT	1849830.3	1177426.0	22
SB I-94(RYAN)	1288+25.7	105.1 LT	1850203.4	1177419.9	16
TOTAL (>15 UNITS)					116

F.A.I. RTE.	SECTION	COUNTY	TOTAL SHEETS	SHEET NO.
94	*	COOK	764	42
STA. 88+60 (SB I-57) TO STA. 1313+00 (SB RYAN)				
STA. 1126+91 (SB FORD)				
FED. ROAD DIST. NO.	ILLINOIS	FED. AID PROJECT		
			62593	
*(1516.1, 1717, & 1818) R-5				

CHAIN LINK FENCE REMOVAL

DESCRIPTION OF EXISTING LOCATION	FROM			TO			CH LK FENCE REMOV (FOOT)
	ALIGNMENT	STATION	OFFSET	ALIGNMENT	STATION	OFFSET	
SB I-94 (DAN RYAN EXPRESSWAY)	SB I-57	149+51.3	34.8 RT	SB I-57	150+10.6	34.3 RT	63
SB I-94 (DAN RYAN EXPRESSWAY)	SB I-94(RYAN)	1223+60.0	8.2 RT	SB I-94(RYAN)	1224+30.0	8.6 RT	71
SB I-94 (DAN RYAN EXPRESSWAY)	SB I-94(RYAN)	1250+78.7	8.7 RT	SB I-94(RYAN)	1251+49.8	8.2 RT	71
SB I-94 (DAN RYAN EXPRESSWAY)	SB I-94(RYAN)	1276+32.0	7.9 RT	SB I-94(RYAN)	1276+92.0	7.9 RT	63
SB I-94 (DAN RYAN EXPRESSWAY)	SB I-94(RYAN)	1286+50.0	9.2 RT	SB I-94(RYAN)	1287+10.0	8.0 RT	62
1000-2A TOTAL							
J000-2A TOTAL							330
TOTAL							330

GUARDRAIL REMOVAL

DESCRIPTION OF EXISTING LOCATION	FROM			TO			GUARDRAIL REMOV (FOOT)
	ALIGNMENT	STATION	OFFSET	ALIGNMENT	STATION	OFFSET	
SB I-57	SB I-57	90+87.6	37.3 LT	SB I-57	92+91.7	39.1 LT	205
HALSTED STREET EXIT RAMP	SB I-57	103+99.4	61.9 LT	SB I-57	104+79.7	54.2 LT	81
1000-2A TOTAL							
J000-2A TOTAL							286
TOTAL							286

NOTES:

"ALIGNMENT" REFERS TO PROPOSED ALIGNMENTS

REVISIONS	
NAME	DATE

ILLINOIS DEPARTMENT OF TRANSPORTATION
F.A.I. 94 (DAN RYAN EXPRESSWAY)

SCHEDULE OF QUANTITIES
REMOVAL QUANTITIES - SHEET 4

SCALE: NONE DRAWN BY: MPG
DATE: MARCH 1, 2006 CHECKED BY: RTM

ADDENDUM 1 05/08/06

F.A.I. RTE.	SECTION	COUNTY	TOTAL SHEETS	SHEET NO.
94		COOK	764	44
STA. 1126+91 (SB FORD) TO STA. 1313+00 (SB RYAN)				
FED. ROAD DIST. NO. ILLINOIS FED. AID PROJECT				
• (1516.1, 1717, & 1818) R-5				
				62593

COMBINATION CONCRETE CURB AND GUTTER, TYPE M-2.24

LOCATION DESCRIPTION	FROM			TO			COMB CC&G TM2.24 (FOOT)	PROTECTIVE COAT (SQ YD)
	ALIGNMENT	STATION	OFFSET	ALIGNMENT	STATION	OFFSET		
SB I-57	SB I-57	102+73.1	41.5 LT	SB I-57	103+23.2	46.5 LT	56.5	16
SB I-57	SB I-57	141+61.8	48.0 LT	SB I-57	142+13.2	52.0 LT	56.5	16
SB I-57	SB I-57	145+93.1	10.0 RT	SB I-57	146+45.0	11.8 RT	53.5	15
SB I-94 (BISHOP FORD)	SB I-94(FORD)	1169+11.6	10.0 LT	SB I-94(FORD)	1169+63.4	11.8 LT	53.0	15
SB I-94 (DAN RYAN)	SB I-94(RYAN)	1221+12.9	72.0 LT	SB I-94(RYAN)	1221+67.9	76.0 LT	61.5	18
SB I-94 (DAN RYAN)	SB I-94(RYAN)	1271+27.4	72.0 LT	SB I-94(RYAN)	1271+77.6	76.0 LT	56.5	16
I000-2A TOTAL								
J000-2A TOTAL							337.5	96
TOTAL							337.5	96

COMBINATION CONCRETE CURB AND GUTTER, TYPE M-4.48

LOCATION DESCRIPTION	FROM			TO			COMB CC&G TM4.48 (FOOT)	PROTECTIVE COAT (SQ YD)
	ALIGNMENT	STATION	OFFSET	ALIGNMENT	STATION	OFFSET		
SB I-57	SB I-57	143+91.5	62.3 LT	SB I-57	146+20.6	48.0 LT	225.5	118
SB I-94 (DAN RYAN)	SB I-94(RYAN)	1223+71.5	86.3 LT	SB I-94(RYAN)	1226+19.6	72.0 LT	248.5	130
SB I-94 (DAN RYAN)	SB I-94(RYAN)	1241+11.0	72.6 LT	SB I-94(RYAN)	1246+59.2	86.3 LT	548.5	288
SB I-94 (DAN RYAN)	SB I-94(RYAN)	1274+38.2	75.3 LT	SB I-94(RYAN)	1274+75.6	72.0 LT	37.5	20
SB I-94 (DAN RYAN)	SB I-94(RYAN)	1289+96.8	72.0 LT	SB I-94(RYAN)	1295+06.2	86.3 LT	510.0	268
SB I-94 (DAN RYAN)	SB I-94(RYAN)	1306+63.0	86.3 LT	SB I-94(RYAN)	1309+25.4	72.0 LT	263.0	138
I000-2A TOTAL								
J000-2A TOTAL							1833.0	962
TOTAL							1833.0	962

COMBINATION CONCRETE CURB AND GUTTER, TYPE M-4.24

LOCATION DESCRIPTION	FROM			TO			COMB CC&G TM4.24 (FOOT)	PROTECTIVE COAT (SQ YD)
	ALIGNMENT	STATION	OFFSET	ALIGNMENT	STATION	OFFSET		
SB I-57	SB I-57	89+45.0	36.0 LT	SB I-57	89+78.7	36.5 LT	34.0	10
SB I-57	SB I-57	92+87.5	36.0 LT	SB I-57	102+73.1	41.5 LT	986.0	299
SB I-57	SB I-57	109+15.4	48.0 LT	SB I-57	116+15.3	44.9 LT	700.5	212
SB I-57	SB I-57	119+61.0	48.0 LT	SB I-57	130+07.7	42.0 LT	1025.5	310
SB I-57	SB I-57	131+43.9	11.9 RT	SB I-57	133+04.0	10.0 RT	162.0	49
SB I-57	SB I-57	134+50.0	10.0 RT	SB I-57	145+93.1	10.0 RT	1149.0	348
SB I-57	SB I-57	134+50.0	48.0 LT	SB I-57	141+61.8	48.0 LT	694.0	210
SB I-57	SB I-57	146+20.6	48.0 LT	SB I-57	155+46.0	41.2 LT	911.0	276
WB CONNECTOR	WB CON	340+29.2	12.0 RT	WB CON	340+81.0	13.9 RT	53.0	16
EB CONNECTOR	EB CON	415+06.0	10.0 LT	EB CON	419+85.1	10.0 LT	482.5	146
EB CONNECTOR	EB CON	415+06.0	34.0 RT	EB CON	420+30.5	34.0 RT	512.0	155
EB CON - SB I-94 (FORD)	EB CON	421+95.4	34.2 RT	SB I-94(FORD)	1146+26.7	33.1 LT	749.0	227
EB CONNECTOR	EB CON	422+31.9	8.3 LT	EB CON	424+40.3	11.9 LT	210.0	64
SB I-94 (BISHOP FORD)	SB I-94(FORD)	1130+05.8	22.0 LT	SB I-94(FORD)	1144+06.8	26.7 LT	1409.5	427
SB I-94 (BISHOP FORD)	SB I-94(FORD)	1151+26.4	11.9 LT	SB I-94(FORD)	1153+99.7	9.7 LT	276.0	84
SB I-94 (BISHOP FORD)	SB I-94(FORD)	1168+14.3	10.0 LT	SB I-94(FORD)	1169+11.6	10.0 LT	98.0	30
SB I-94 (DAN RYAN)	SB I-94(RYAN)	1212+30.3	72.0 LT	SB I-94(RYAN)	1216+75.0	72.0 LT	445.0	135
SB I-94 (DAN RYAN)	SB I-94(RYAN)	1218+75.0	72.0 LT	SB I-94(RYAN)	1221+12.9	72.0 LT	238.0	72
SB I-94 (DAN RYAN)	SB I-94(RYAN)	1226+19.6	72.0 LT	SB I-94(RYAN)	1227+53.8	72.0 LT	134.5	41
SB I-94 (DAN RYAN)	SB I-94(RYAN)	1235+41.2	68.0 LT	SB I-94(RYAN)	1235+41.2	76.1 LT	8.5	3
SB I-94 (DAN RYAN)	SB I-94(RYAN)	1248+94.1	76.0 LT	SB I-94(RYAN)	1251+12.6	72.0 LT	224.5	68
SB I-94 (DAN RYAN)	SB I-94(RYAN)	1252+87.6	72.0 LT	SB I-94(RYAN)	1257+59.7	72.0 LT	472.0	143
SB I-94 (DAN RYAN)	SB I-94(RYAN)	1261+63.3	72.0 LT	SB I-94(RYAN)	1271+27.4	72.0 LT	964.5	292
SB I-94 (DAN RYAN)	SB I-94(RYAN)	1274+75.6	72.0 LT	SB I-94(RYAN)	1283+91.3	72.0 LT	916.0	277
SB I-94 (DAN RYAN)	SB I-94(RYAN)	1289+16.6	72.0 LT	SB I-94(RYAN)	1289+96.8	72.0 LT	80.5	24
SB I-94 (DAN RYAN)	SB I-94(RYAN)	1309+25.4	72.0 LT	SB I-94(RYAN)	1312+15.9	64.1 LT	291.0	88
I000-2A TOTAL							3639.0	1102
J000-2A TOTAL							9587.5	2903
TOTAL							13226.5	4005

TYLIN INTERNATIONAL

REVISIONS	
NAME	DATE

ILLINOIS DEPARTMENT OF TRANSPORTATION
F.A.I. 94 (DAN RYAN EXPRESSWAY)

SCHEDULE OF QUANTITIES
PROPOSED QUANTITIES - SHEET 2

SCALE: NONE DRAWN BY: MPG
DATE: MARCH 1, 2006 CHECKED BY: RTM

ADDENDUM 1 05/08/06

05/04/2006 09:23:20 PM

CONCRETE BARRIER

LOCATION DESCRIPTION	FROM			TO			CONC BAR SIN FACE 32 (FOOT)	CONC BAR SIN FACE 32 SPL (FOOT)	CONC BAR SIN FACE 32 MOD (FOOT)	CONC BAR SIN FACE 42 (FOOT)	CONC BAR SIN FACE 42 SPL (FOOT)	CONC BAR TRANS (FOOT)	BARRIER BASE (FOOT)	BAR WALL MKR TYPE C (EACH)	PROTECTIVE COAT (SQ YD)
	ALIGNMENT	STATION	OFFSET	ALIGNMENT	STATION	OFFSET									
SB I-57	SB I-57	90+87.6	36.8 LT	SB I-57	91+02.6	36.0 LT						15	15		12
SB I-57	SB I-57	91+02.6	36.0 LT	SB I-57	92+87.5	36.0 LT	185						185	5	141
SB I-57	SB I-57	103+99.4	61.9 LT	SB I-57	106+37.9	41.8 LT	240						240	5	183
SB I-57	SB I-57	106+37.9	41.8 LT	SB I-57	106+52.9	41.8 LT						15	15		12
SB I-57	SB I-57	107+15.5	41.9 LT	SB I-57	107+30.5	42.5 LT						15	15		12
SB I-57	SB I-57	107+30.5	42.5 LT	SB I-57	109+15.4	48.0 LT	185						185	5	141
SB I-57	SB I-57	116+92.4	43.0 LT	SB I-57	117+07.4	43.0 LT						15	15		12
SB I-57	SB I-57	117+07.4	43.0 LT	SB I-57	119+61.0	48.0 LT	254						254	5	193
SB I-57	SB I-57	130+07.7	42.0 LT	SB I-57	134+50.0	48.0 LT	432						432	6	329
SB I-57	SB I-57	107+15.6	22.2 RT	SB I-57	107+30.6	22.0 RT						15	15		12
SB I-57	SB I-57	107+30.6	22.0 RT	SB I-57	116+34.3	22.0 RT	904						904	7	688
SB I-57	SB I-57	116+34.3	22.0 RT	SB I-57	116+49.3	22.0 RT						15	15		12
SB I-57	SB I-57	116+91.6	22.0 RT	SB I-57	117+06.6	22.0 RT						15	15		12
SB I-57	SB I-57	117+06.6	22.0 RT	SB I-57	129+50.1	35.5 RT	1255						1255	8	955
SB I-57	SB I-57	129+50.1	35.5 RT	SB I-57	129+64.7	34.0 RT						15	15		12
SB I-57	SB I-57	133+13.9	10.0 RT	SB I-57	133+28.9	10.0 RT						15	15		12
SB I-57	SB I-57	133+28.9	10.0 RT	SB I-57	134+50.0	10.0 RT	122						122	5	93
WB CONNECTOR	WB CON	340+29.2	26.0 LT	WB CON	341+55.5	26.0 LT	127						127	5	97
WB CONNECTOR	WB CON	341+55.5	26.0 LT	WB CON	341+70.5	25.1 LT						15	15		12
EB CONNECTOR	EB CON	419+85.1	10.0 LT	EB CON	420+69.5	8.3 LT	85						85	5	65
EB CONNECTOR	EB CON	420+69.5	8.3 LT	EB CON	420+84.4	8.6 LT						15	15		12
EB CONNECTOR	EB CON	420+30.5	34.0 RT	EB CON	420+66.3	34.2 RT	35						35	5	27
EB CONNECTOR	EB CON	420+66.3	34.2 RT	EB CON	420+81.7	34.0 RT						15	15		12
SB I-94 (BISHOP FORD)	SB I-94(FORD)	1126+90.8	22.2 LT	SB I-94(FORD)	1127+05.8	22.0 LT						15	15		12
SB I-94 (BISHOP FORD)	SB I-94(FORD)	1127+05.8	22.0 LT	SB I-94(FORD)	1130+05.8	22.0 LT	300						300	5	228
SB I-94 (BISHOP FORD)	SB I-94(FORD)	1144+87.0	29.5 LT	SB I-94(FORD)	1145+01.8	29.8 LT						15	15		12
SB I-94 (BISHOP FORD)	SB I-94(FORD)	1145+01.8	29.8 LT	SB I-94(FORD)	1146+26.7	33.1 LT	127						127	5	97
SB I-94 (BISHOP FORD)	SB I-94(FORD)	1164+17.0	11.1 LT	SB I-94(FORD)	1167+89.8	11.4 LT			376				376	5	131
SB I-94 (BISHOP FORD)	SB I-94(FORD)	1167+89.8	11.4 LT	SB I-94(FORD)	1168+14.3	10.0 LT	25						25	5	19
SB I-94 (BISHOP FORD)	SB I-94(FORD)	1164+12.5	34.0 RT	SB I-94(FORD)	1167+78.3	32.0 RT			360				360	5	126
SB I-94 (BISHOP FORD)	SB I-94(FORD)	1167+78.3	32.0 RT	SB I-94(FORD)	1167+93.6	31.9 RT						15	15		12
SB I-94 (DAN RYAN)	SB I-57	155+46.0	41.2 LT	SB I-57	155+90.9	39.7 LT	45						45	5	34
SB I-94 (DAN RYAN)	SB I-57	155+90.9	39.7 LT	SB I-57	156+05.9	39.2 LT						15	15		12
SB I-94 (DAN RYAN)	SB I-94(RYAN)	1209+97.1	63.0 LT	SB I-94(RYAN)	1210+12.1	63.6 LT						15	15		12
SB I-94 (DAN RYAN)	SB I-94(RYAN)	1210+12.1	63.6 LT	SB I-94(RYAN)	1212+30.3	72.0 LT	219						219	5	167
SB I-94 (DAN RYAN)	SB I-94(RYAN)	1216+75.0	72.0 LT	SB I-94(RYAN)	1218+75.0	72.0 LT	200						200	5	152
SB I-94 (DAN RYAN)	SB I-94(RYAN)	1227+53.8	72.0 LT	SB I-94(RYAN)	1232+13.8	72.0 LT	460						460	6	350
SB I-94 (DAN RYAN)	SB I-94(RYAN)	1232+13.8	72.0 LT	SB I-94(RYAN)	1232+28.8	72.7 LT						15	15		12
SB I-94 (DAN RYAN)	SB I-94(RYAN)	1233+00.0	72.6 LT	SB I-94(RYAN)	1233+15.0	72.0 LT						15	15		12
SB I-94 (DAN RYAN)	SB I-94(RYAN)	1233+15.0	72.0 LT	SB I-94(RYAN)	1235+41.8	76.1 LT	227						227	5	173
SB I-94 (DAN RYAN)	SB I-94(RYAN)	1235+39.2	66.0 LT	SB I-94(RYAN)	1236+13.3	64.6 LT	75						75	5	57
SB I-94 (DAN RYAN)	SB I-94(RYAN)	1236+13.3	64.6 LT	SB I-94(RYAN)	1236+28.2	63.1 LT						15	15		12
SB I-94 (DAN RYAN)	SB I-94(RYAN)	1237+19.6	65.4 LT	SB I-94(RYAN)	1237+34.6	65.9 LT						15	15		12
SB I-94 (DAN RYAN)	SB I-94(RYAN)	1237+34.6	65.9 LT	SB I-94(RYAN)	1237+76.5	67.4 LT	42						42	5	32
SB I-94 (DAN RYAN)	SB I-94(RYAN)	1237+76.5	67.4 LT	SB I-94(RYAN)	1237+91.5	67.9 LT						15	15		12
SB I-94 (DAN RYAN)	SB I-94(RYAN)	1239+11.1	67.6 LT	SB I-94(RYAN)	1239+26.1	68.0 LT						15	15		12
SB I-94 (DAN RYAN)	SB I-94(RYAN)	1239+26.1	68.0 LT	SB I-94(RYAN)	1241+11.0	72.6 LT	185						185	5	141
SB I-94 (DAN RYAN)	SB I-94(RYAN)	1251+12.6	72.0 LT	SB I-94(RYAN)	1252+87.6	72.0 LT	175						175	5	133
SB I-94 (DAN RYAN)	SB I-94(RYAN)	1257+59.7	72.0 LT	SB I-94(RYAN)	1258+34.9	64.5 LT	76						76	5	58
SB I-94 (DAN RYAN)	SB I-94(RYAN)	1258+34.9	64.5 LT	SB I-94(RYAN)	1258+49.8	63.0 LT						15	15		12
SB I-94 (DAN RYAN)	SB I-94(RYAN)	1259+61.0	64.2 LT	SB I-94(RYAN)	1259+76.0	64.8 LT						15	15		12
SB I-94 (DAN RYAN)	SB I-94(RYAN)	1259+76.0	64.8 LT	SB I-94(RYAN)	1261+63.3	72.0 LT	188						188	5	143
SB I-94 (DAN RYAN)	SB I-94(RYAN)	1283+91.3	72.0 LT	SB I-94(RYAN)	1285+25.9	65.3 LT	135						135	5	103
SB I-94 (DAN RYAN)	SB I-94(RYAN)	1285+25.9	65.3 LT	SB I-94(RYAN)	1285+40.8	63.8 LT						15	15		12

F.A.I. RTE.	SECTION	COUNTY	TOTAL SHEETS	SHEET NO.
94	*	COOK	764	46

STA. 88+60 (SB I-57) TO STA. 1313+00 (SB RYAN)
 STA. 1126+91 (SB FORD) TO STA. 1313+00 (SB RYAN)
 FED. ROAD DIST. NO. ILLINOIS FED. AID PROJECT
 * (1516.1, 1717, & 1818) R-5
 62593

(CONT. NEXT SHEET)

TYLIN INTERNATIONAL

REVISIONS	
NAME	DATE

ADDENDUM 1 05/08/06

ILLINOIS DEPARTMENT OF TRANSPORTATION
 F.A.I. 94 (DAN RYAN EXPRESSWAY)
 SCHEDULE OF QUANTITIES
 PROPOSED QUANTITIES - SHEET 4
 SCALE: NONE DRAWN BY: MPG
 DATE: MARCH 1, 2006 CHECKED BY: RTM

05/04/2006 09:23:20 PM

F.A.I. RTE.	SECTION	COUNTY	TOTAL SHEETS	SHEET NO.
94		COOK	764	76
STA. 88+60 (SB I-57) TO STA. 1313+00 (SB RYAN)				
STA. 126+91 (SB FORD) TO STA. 1313+00 (SB RYAN)				
FED. ROAD DIST. NO. ILLINOIS FED. AID PROJECT				
• (1516.1, 1717, & 1818) R-5				
				62593

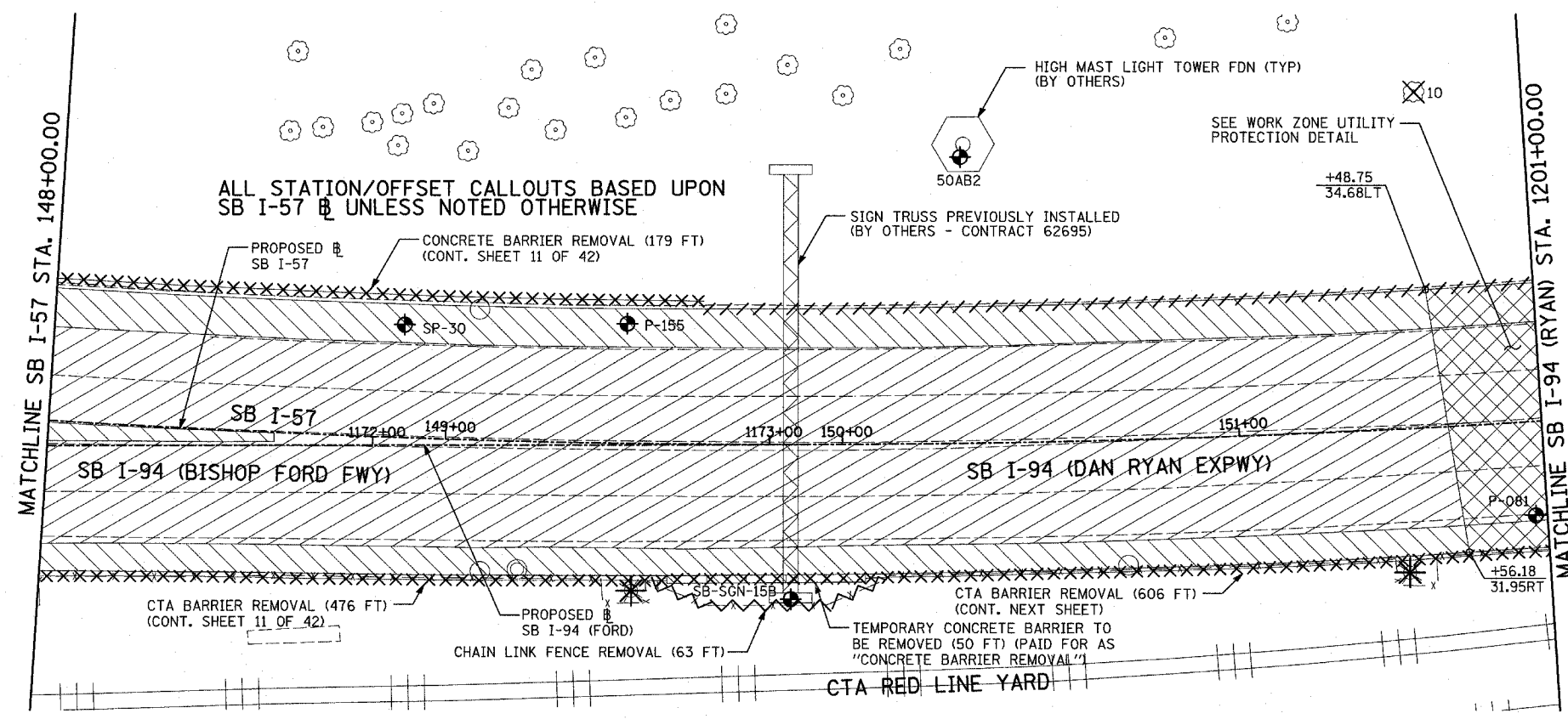

EXISTING CONDITIONS
PROPOSED IMPROVEMENTS

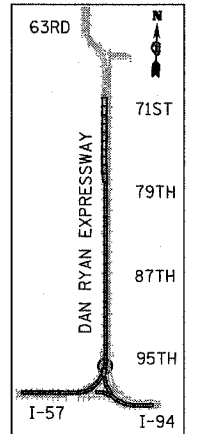
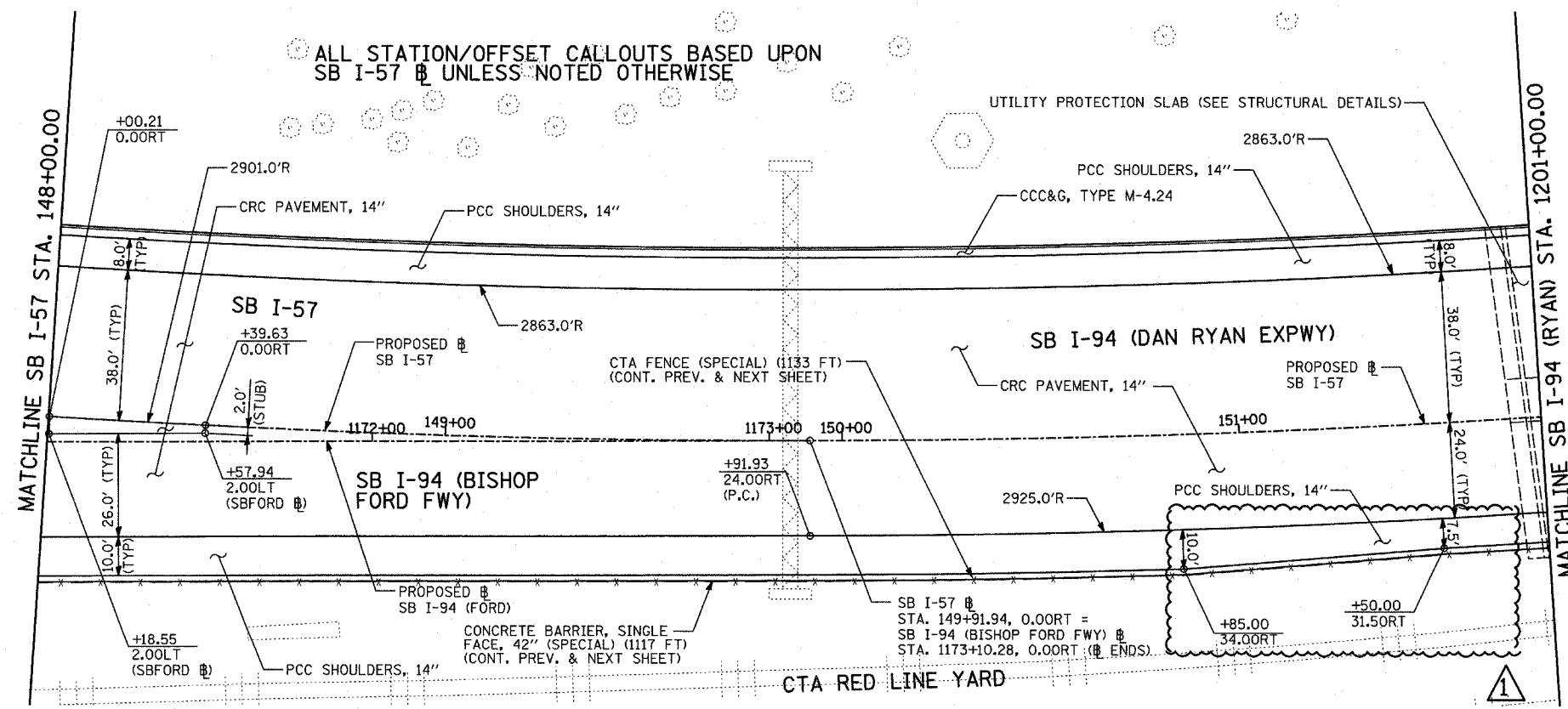

LOCATION MAP

LEGEND:

	PAVEMENT REMOVAL		BITUMINOUS SURFACE REMOVAL, 1 3/4"		SOIL BORING LOCATIONS
	PAVED SHOULDER REMOVAL		PAVEMENT/SHOULDER REMOVAL (SPECIAL) (OVER EXISTING UTILITIES)		LIGHT POLE FOUNDATION REMOVAL (SEE ROADWAY LIGHTING & SURVEILLANCE PLANS)
	BITUMINOUS SURFACE REMOVAL, 4"		COMB CONC CURB & GUTTER REMOVAL		TREE REMOVAL (UNITS) (NO UNIT SHOWN = <6)
	BITUMINOUS SURFACE REMOVAL, 1 1/2"		CHAIN LINK FENCE REMOVAL		MAINLINE STATION/OFFSET
			CONCRETE BARRIER/GUARDRAIL REMOVAL		

PLAN NOTES:

- ALL STATION/OFFSET/RADIUS CALLOUTS MEASURED TO EDGE OF PAVEMENT UNLESS OTHERWISE NOTED.
- EXACT LOCATIONS OF EXISTING PIERS/ABUTMENTS TO BE FIELD VERIFIED

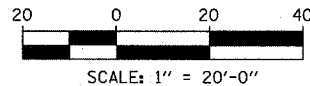

REVISIONS	
NAME	DATE

ILLINOIS DEPARTMENT OF TRANSPORTATION
F.A.I. 94 (DAN RYAN EXPRESSWAY)
EXISTING AND PROPOSED PLAN
SB I-94 (RYAN/FORD) & SB I-57
SB I-57 STA. 148+00.00 TO
SB I-94 (RYAN) STA. 1201+00.00

SCALE: 1"=20'
DATE: MARCH 1, 2006
DRAWN BY: MPG
CHECKED BY: RTM

TYLIN INTERNATIONAL

ADDENDUM 1 05/08/06

05/04/2006 04:23:39 PM

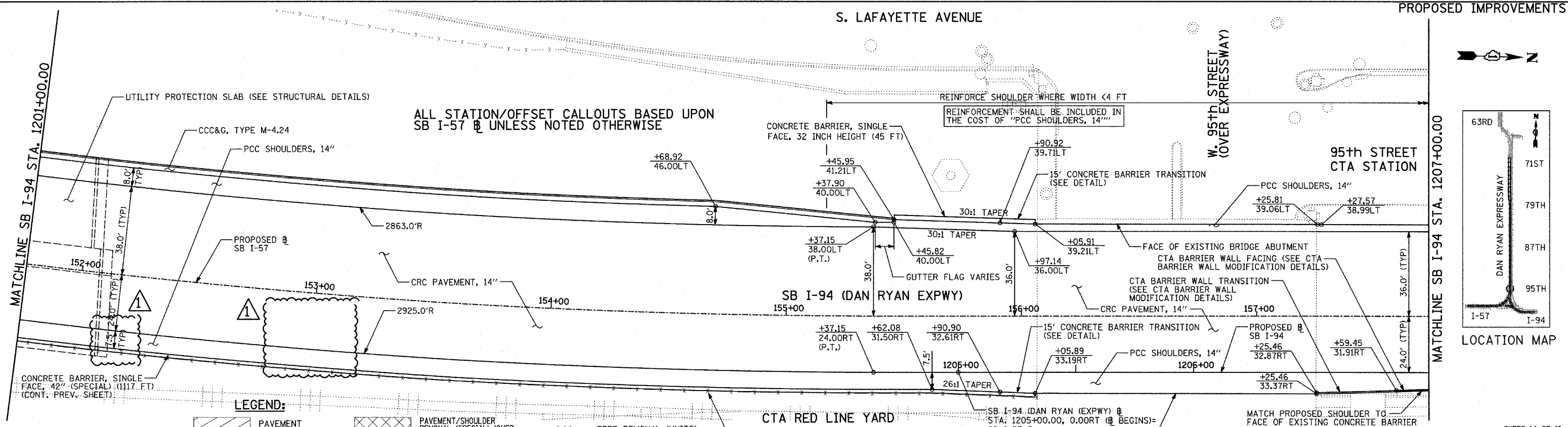
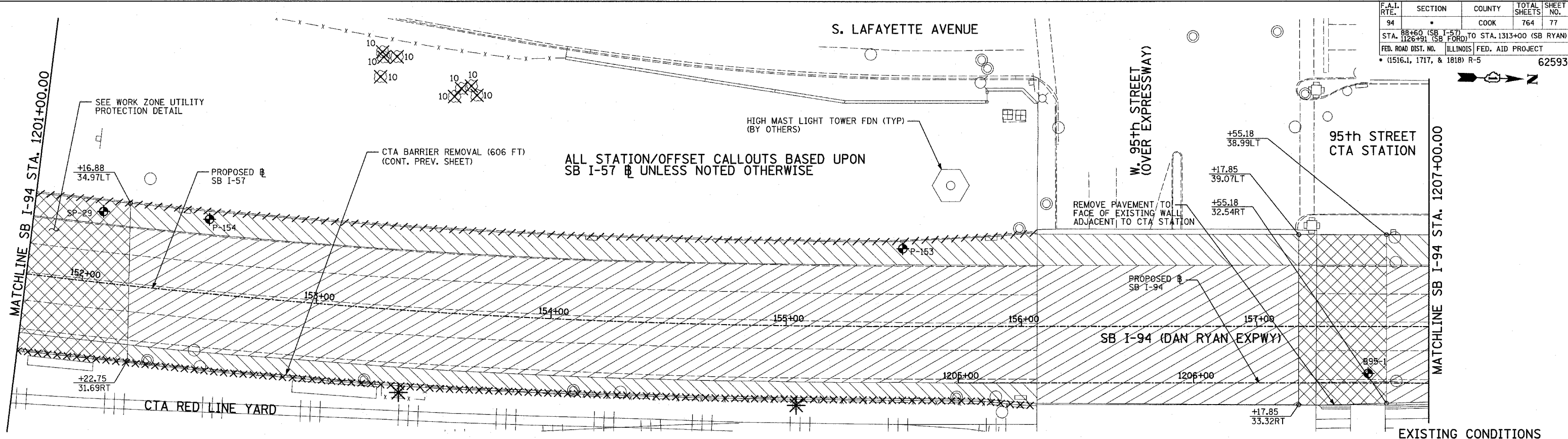

TYLIN INTERNATIONAL

LEGEND:

	PAVEMENT REMOVAL		PAVEMENT/SHOULDER REMOVAL (SPECIAL) (OVER EXISTING UTILITIES)		TREE REMOVAL (UNITS) (NO UNIT SHOWN = <6)
	PAVED SHOULDER REMOVAL		COMB CONC CURB & GUTTER REMOVAL		MAINLINE STATION/OFFSET
	BITUMINOUS SURFACE REMOVAL, 4"		CHAIN LINK FENCE REMOVAL		CONCRETE BARRIER/GUARDRAIL REMOVAL
	BITUMINOUS SURFACE REMOVAL, 1 1/2"		SOIL BORING LOCATIONS		LIGHT POLE FOUNDATION REMOVAL (SEE ROADWAY LIGHTING & SURVEILLANCE PLANS)
	BITUMINOUS SURFACE REMOVAL, 1 3/4"				

PLAN NOTES:

- ALL STATION/OFFSET/RADIUS CALLOUTS MEASURED TO EDGE OF PAVEMENT UNLESS OTHERWISE NOTED.
- EXACT LOCATIONS OF EXISTING PIERS/ABUTMENTS TO BE FIELD VERIFIED

SHEET 14 OF 42

SCALE: 1" = 20'-0"

REVISIONS	
NAME	DATE
ADDENDUM 1	05/08/06

ILLINOIS DEPARTMENT OF TRANSPORTATION
F.A.I. 94 (DAN RYAN EXPRESSWAY)
 EXISTING AND PROPOSED PLAN
 SB I-94 (DAN RYAN EXPRESSWAY)
 SB I-94 STA. 1201+00.00 TO 1207+00.00

SCALE: 1"=20'
 DATE: MARCH 1, 2006
 DRAWN BY: MPG
 CHECKED BY: RTM

F.A.I. RTE.	SECTION	COUNTY	TOTAL SHEETS	SHEET NO.
94		COOK	764	83
STA. 88+60 (SB I-57) TO STA. 126+91 (SB FORD) TO STA. 1313+00 (SB RYAN)				
FED. ROAD DIST. NO. ILLINOIS FED. AID PROJECT				
• (1516.1, 1717, & 1818) R-5 62593				

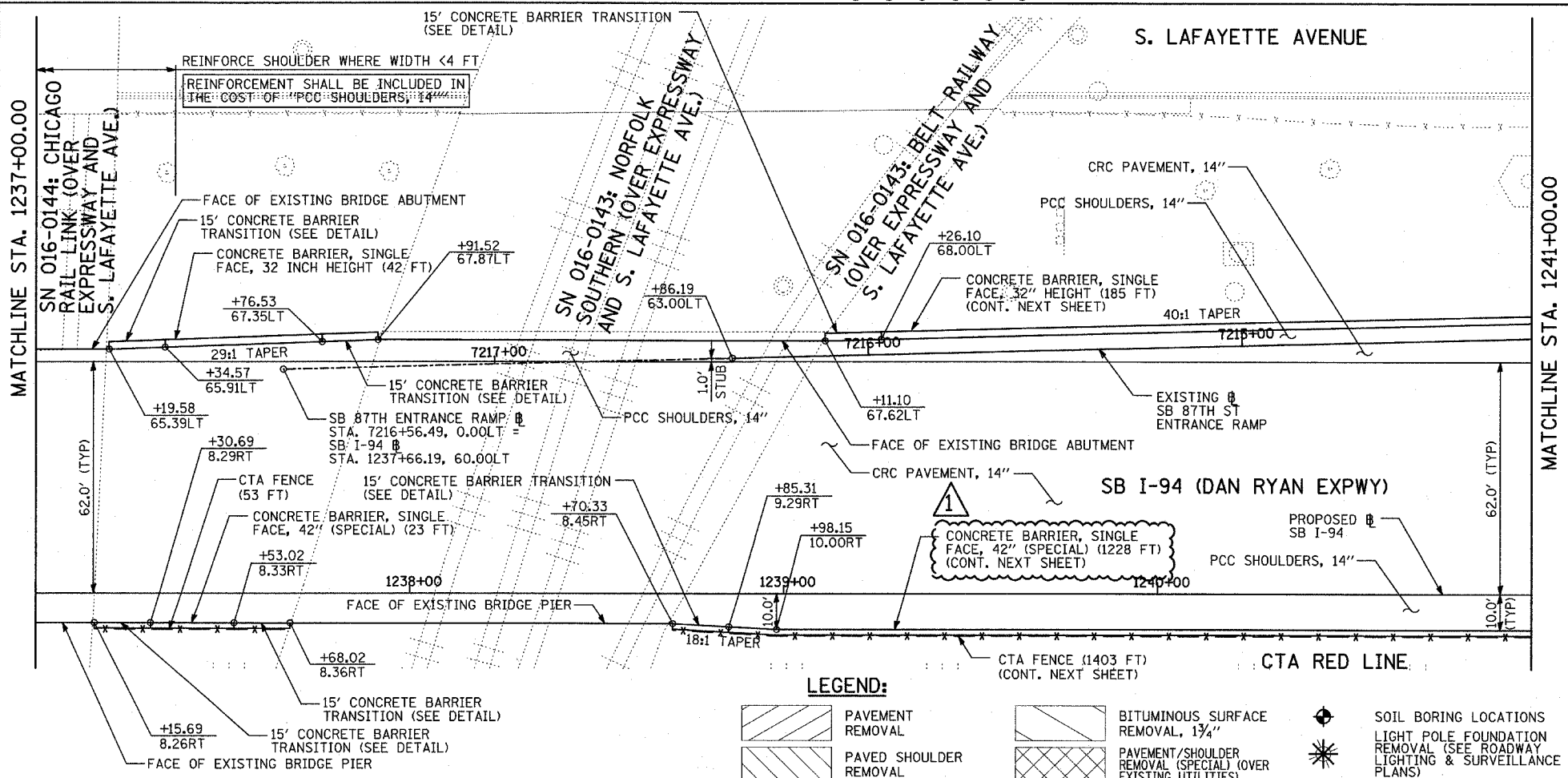
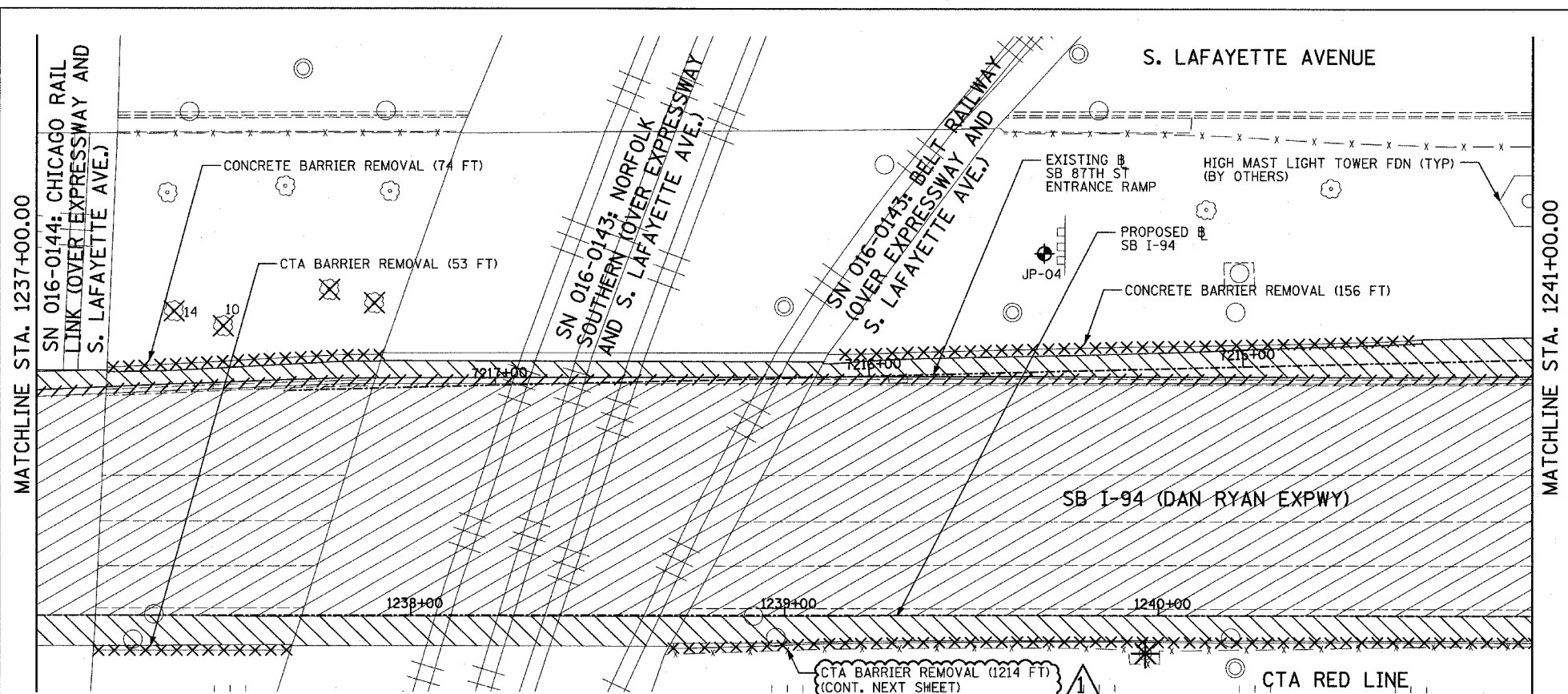

EXISTING CONDITIONS
PROPOSED IMPROVEMENTS

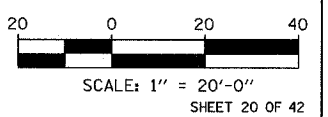
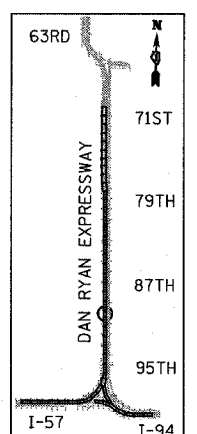

LEGEND:

- | | | |
|------------------------------------|---|---|
| PAVEMENT REMOVAL | BITUMINOUS SURFACE REMOVAL, 1 1/2" | SOIL BORING LOCATIONS |
| PAVED SHOULDER REMOVAL | PAVEMENT/SHOULDER REMOVAL (SPECIAL) (OVER EXISTING UTILITIES) | LIGHT POLE FOUNDATION REMOVAL (SEE ROADWAY LIGHTING & SURVEILLANCE PLANS) |
| BITUMINOUS SURFACE REMOVAL, 4" | COMB CONC CURB & GUTTER REMOVAL | TREE REMOVAL (UNITS) (NO UNIT SHOWN = <6) |
| BITUMINOUS SURFACE REMOVAL, 1 1/2" | CHAIN LINK FENCE REMOVAL | MAINLINE STATION/OFFSET |
| CONCRETE BARRIER/GUARDRAIL REMOVAL | CONCRETE BARRIER/GUARDRAIL REMOVAL | |

PLAN NOTES:

- ALL STATION/OFFSET/RADIUS CALLOUTS MEASURED TO EDGE OF PAVEMENT UNLESS OTHERWISE NOTED.
- EXACT LOCATIONS OF EXISTING PIERS/ABUTMENTS TO BE FIELD VERIFIED

REVISIONS	
NAME	DATE

ILLINOIS DEPARTMENT OF TRANSPORTATION
F.A.I. 94 (DAN RYAN EXPRESSWAY)
EXISTING AND PROPOSED PLAN
SB I-94 (DAN RYAN EXPRESSWAY)
SB I-94 STA. 1237+00.00 TO 1241+00.00

SCALE: 1"=20'
DATE: MARCH 1, 2006
DRAWN BY: MPG
CHECKED BY: RTM

TYLIN INTERNATIONAL

ADDENDUM 1 05/08/06

S. LAFAYETTE AVENUE

F.A.I. RTE.	SECTION	COUNTY	TOTAL SHEETS	SHEET NO.
94		COOK	764	84
STA. 88+60 (SB I-57) TO STA. 1126+91 (SB FORD) TO STA. 1313+00 (SB RYAN)				
FED. ROAD DIST. NO. ILLINOIS FED. AID PROJECT				
• (1516.1, 1717, & 1818) R-5 62593				

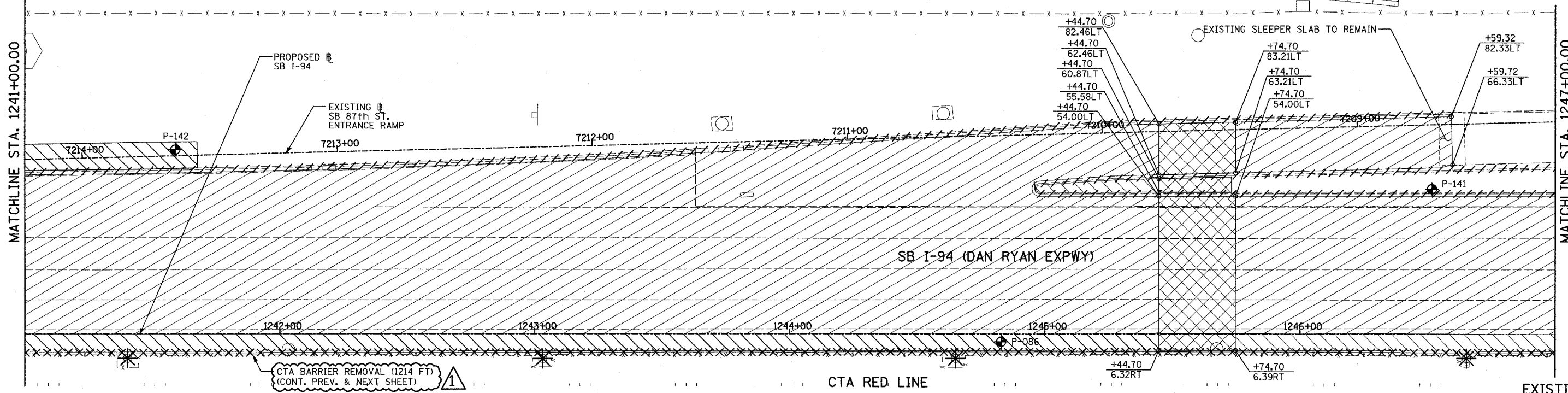

S. LAFAYETTE AVENUE

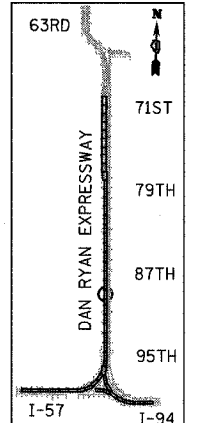
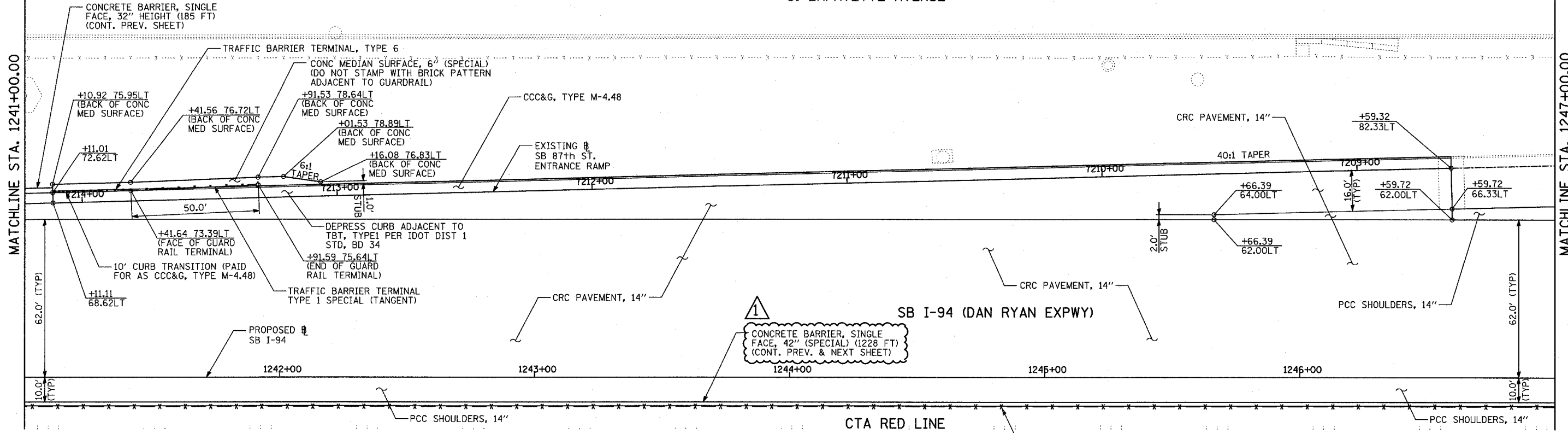

LEGEND:

	PAVEMENT REMOVAL		BITUMINOUS SURFACE REMOVAL, 1 3/4"		SOIL BORING LOCATIONS
	PAVED SHOULDER REMOVAL		PAVEMENT/SHOULDER REMOVAL (SPECIAL) (OVER EXISTING UTILITIES)		LIGHT POLE FOUNDATION REMOVAL (SEE ROADWAY LIGHTING & SURVEILLANCE PLANS)
	BITUMINOUS SURFACE REMOVAL, 4"		COMB CONC CURB & GUTTER REMOVAL		TREE REMOVAL (UNITS) (NO UNIT SHOWN = <6)
	BITUMINOUS SURFACE REMOVAL, 1 1/2"		CHAIN LINK FENCE REMOVAL		MAINLINE # STATION/OFFSET
			CONCRETE BARRIER/GUARDRAIL REMOVAL		

PLAN NOTES:

- ALL STATION/OFFSET/RADIUS CALLOUTS MEASURED TO EDGE OF PAVEMENT UNLESS OTHERWISE NOTED.
- EXACT LOCATIONS OF EXISTING PIERS/ABUTMENTS TO BE FIELD VERIFIED

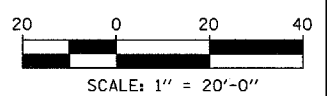

REVISIONS	
NAME	DATE

ILLINOIS DEPARTMENT OF TRANSPORTATION
 F.A.I. 94 (DAN RYAN EXPRESSWAY)
 EXISTING AND PROPOSED PLAN
 SB I-94 (DAN RYAN EXPRESSWAY)
 SB I-94 STA. 1241+00.00 TO 1247+00.00

SCALE: 1"=20'
 DATE: MARCH 1, 2006
 DRAWN BY: MPG
 CHECKED BY: RTM

TYLIN INTERNATIONAL

F.A.I. RTE.	SECTION	COUNTY	TOTAL SHEETS	SHEET NO.
94		COOK	764	85
STA. 88+50 (SB I-57) TO STA. 112+91 (SB FORD) TO STA. 131+00 (SB RYAN)				
FED. ROAD DIST. NO. ILLINOIS FED. AID PROJECT				
• (1516.1, 1717, & 1818) R-5 62593				

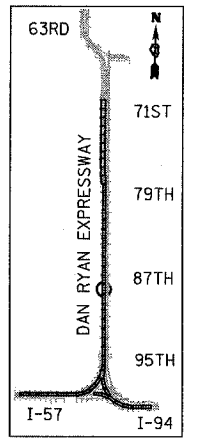
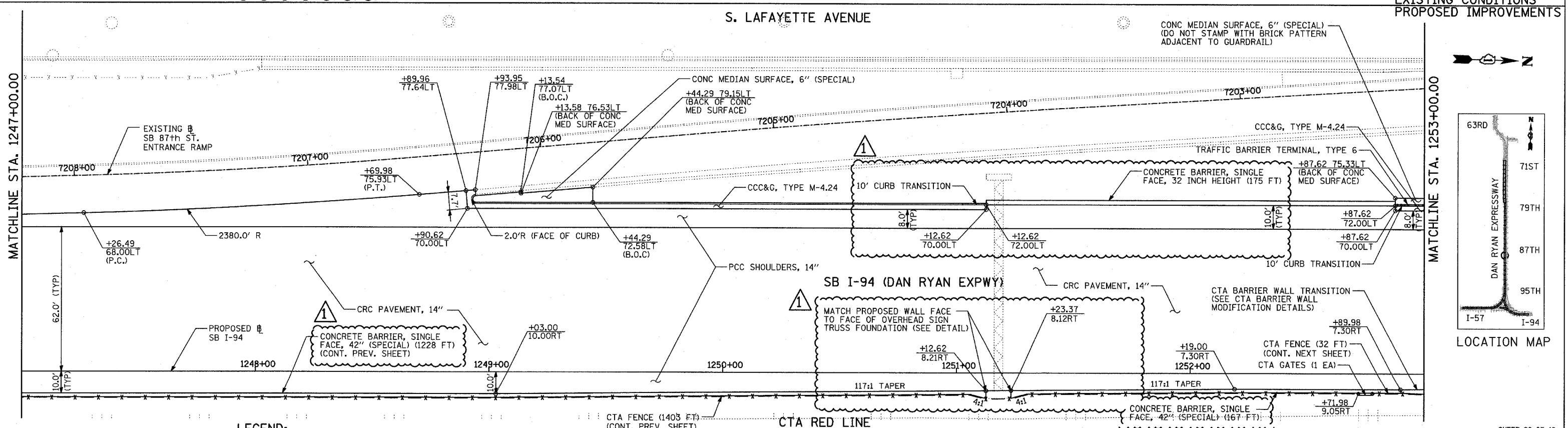
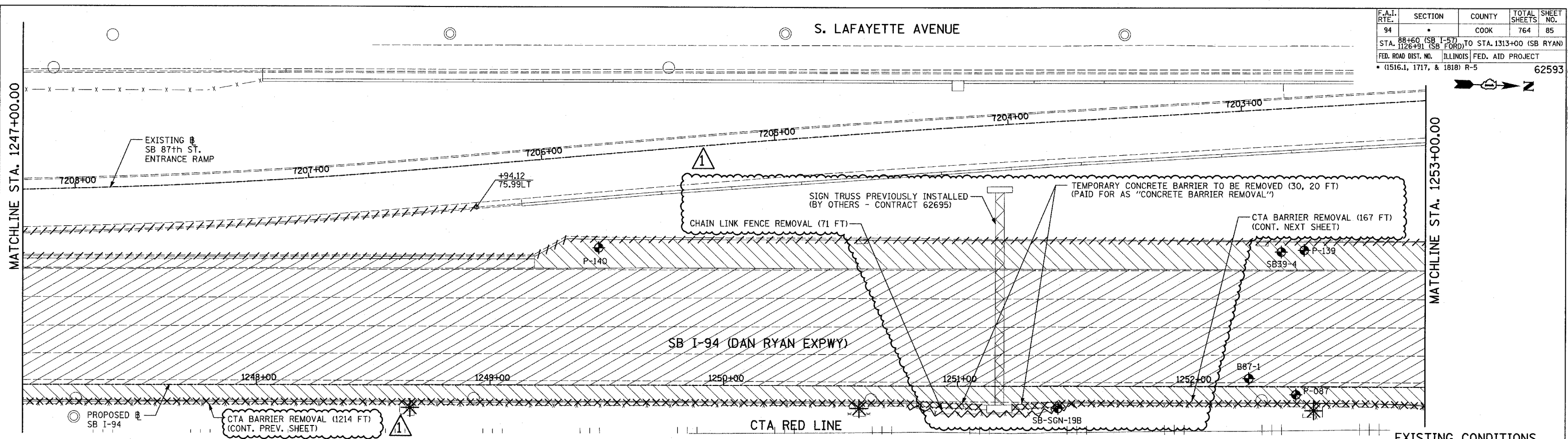

LEGEND:

	PAVEMENT REMOVAL		BITUMINOUS SURFACE REMOVAL, 1 1/2"		SOIL BORING LOCATIONS
	PAVED SHOULDER REMOVAL		PAVEMENT/SHOULDER REMOVAL (SPECIAL) (OVER EXISTING UTILITIES)		LIGHT POLE FOUNDATION REMOVAL (SEE ROADWAY LIGHTING & SURVEILLANCE PLANS)
	BITUMINOUS SURFACE REMOVAL, 4"		COMB CONC CURB & GUTTER REMOVAL		TREE REMOVAL (UNITS) (NO UNIT SHOWN = <6)
	BITUMINOUS SURFACE REMOVAL, 1 1/2"		CHAIN LINK FENCE REMOVAL		MAINLINE @ STATION/OFFSET
			CONCRETE BARRIER/GUARDRAIL REMOVAL		

PLAN NOTES:

- ALL STATION/OFFSET/RADIUS CALLOUTS MEASURED TO EDGE OF PAVEMENT UNLESS OTHERWISE NOTED.
- EXACT LOCATIONS OF EXISTING PIERS/ABUTMENTS TO BE FIELD VERIFIED

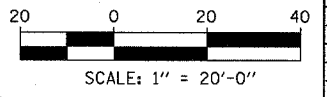

REVISIONS	
NAME	DATE

ILLINOIS DEPARTMENT OF TRANSPORTATION
F.A.I. 94 (DAN RYAN EXPRESSWAY)
EXISTING AND PROPOSED PLAN
SB I-94 (DAN RYAN EXPRESSWAY)
SB I-94 STA. 1247+00.00 TO 1253+00.00

SCALE: 1"=20'
DATE: MARCH 1, 2006
DRAWN BY: MPG
CHECKED BY: RTM

TYLIN INTERNATIONAL

F.A.I. RTE	SECTION	COUNTY	TOTAL SHEETS	SHEET NO.
94		COOK	764	110
STA. 1226+91 (SB FORD) TO STA. 1313+00 (SB RYAN)				
FED. ROAD DIST. NO. ILLINOIS		FED. AID PROJECT		
* (1516.1, 1717, & 1818) R-5		62593		

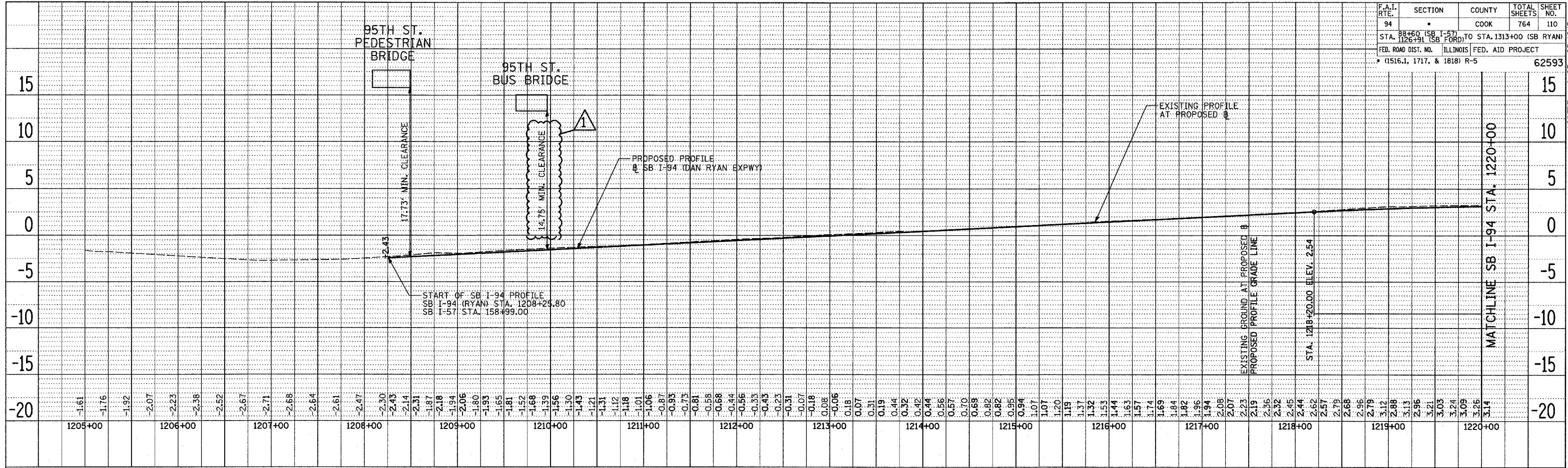

SB I-94 (DAN RYAN EXPRESSWAY)

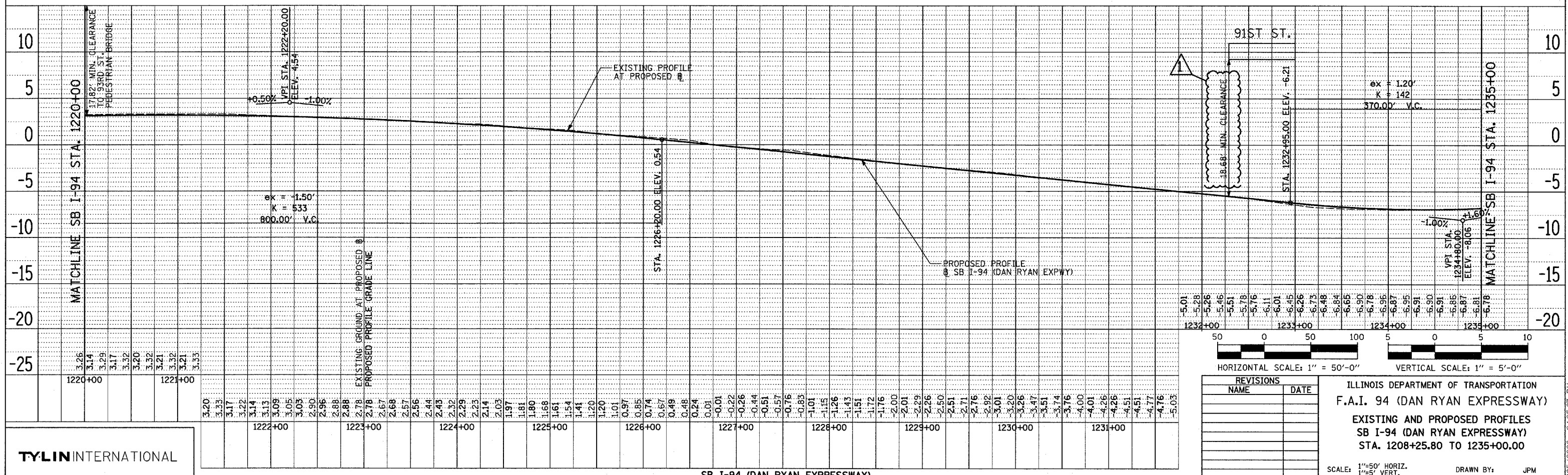

SB I-94 (DAN RYAN EXPRESSWAY)

50 0 50 100 5 0 5 10
 HORIZONTAL SCALE: 1" = 50'-0"
 VERTICAL SCALE: 1" = 5'-0"

REVISIONS	
NAME	DATE

ILLINOIS DEPARTMENT OF TRANSPORTATION
 F.A.I. 94 (DAN RYAN EXPRESSWAY)
 EXISTING AND PROPOSED PROFILES
 SB I-94 (DAN RYAN EXPRESSWAY)
 STA. 1208+25.80 TO 1235+00.00

SCALE: 1"=50' HORIZ.
 1"=5' VERT.
 DATE: MARCH 1, 2006
 DRAWN BY: JPM
 CHECKED BY: MPG

ADDENDUM 1 05/08/06

TYLIN INTERNATIONAL

REVIEWED: _____
 ALIGNED: _____
 CHECKED: _____
 NOTE BOOK NO. _____
 DATE: _____

REVIEWED: _____
 ALIGNED: _____
 CHECKED: _____
 NOTE BOOK NO. _____
 DATE: _____

05/05/2006 04:25:07 PM

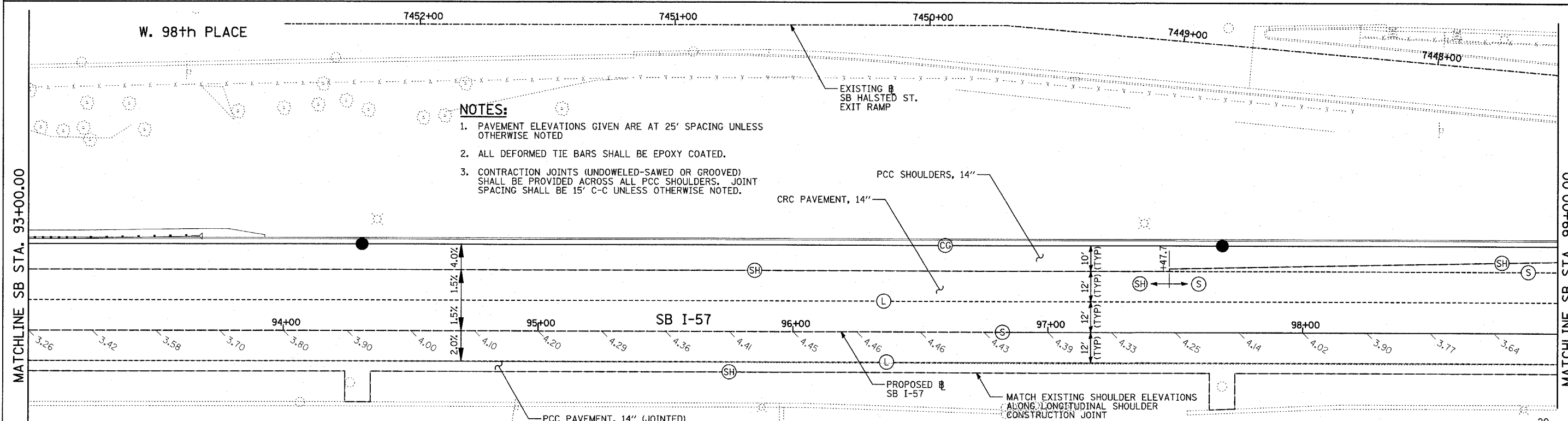
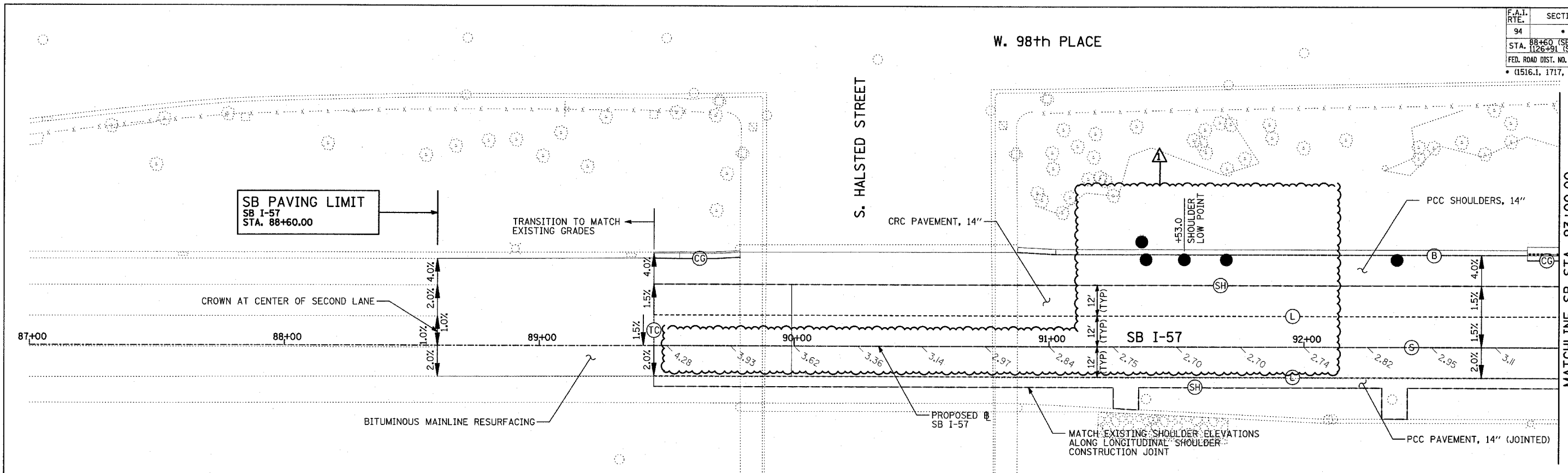

- NOTES:**
1. PAVEMENT ELEVATIONS GIVEN ARE AT 25' SPACING UNLESS OTHERWISE NOTED
 2. ALL DEFORMED TIE BARS SHALL BE EPOXY COATED.
 3. CONTRACTION JOINTS (UNDOWELED-SAWED OR GROOVED) SHALL BE PROVIDED ACROSS ALL PCC SHOULDERS. JOINT SPACING SHALL BE 15' C-C UNLESS OTHERWISE NOTED.

LEGEND:

- (B) LONGITUDINAL BARRIER CONSTRUCTION JOINT. SEE TYPICAL SECTION DETAILS FOR DESCRIPTION.
- (CC) CONSTRUCTION JOINT WITH NO. 6 DEFORMED TIE BAR (EPOXY COATED), 24" LONG @ 24" C-C, DRILL & GROUT IN PLACE (INCLUDED IN THE COST OF CURB & GUTTER)
- (S) SAWED LONGITUDINAL JOINT WITH NO. 6 DEFORMED TIE BAR (EPOXY COATED), 30" LONG @ 30" C-C (INCLUDED IN THE COST OF CRC PAVEMENT)
- (T) TRANSVERSE CONSTRUCTION JOINT WITH 1-1/2" DIA. DEFORMED TIE BARS (EPOXY COATED), 18" LONG @ 12" C-C, DRILL & GROUT IN PLACE (INCLUDED IN THE COST OF PCC PAVEMENT)
- (SH) LONGITUDINAL SHOULDER CONSTRUCTION JOINT WITH NO. 6 DEFORMED TIE BAR (EPOXY COATED), 24" LONG @ 24" C-C, DRILL & GROUT IN PLACE (INCLUDED IN THE COST OF PCC AND CRC PAVEMENT)
- (L) LONGITUDINAL CONSTRUCTION JOINT WITH NO. 6 DEFORMED TIE BAR (EPOXY COATED), 24" LONG @ 24" C-C, DRILL & GROUT IN PLACE (INCLUDED IN THE COST OF CRC PAVEMENT)
- (TC) TRANSVERSE CONSTRUCTION JOINT WITH NO. 8 DEFORMED TIE BAR (EPOXY COATED), 24" LONG @ 24" C-C, DRILL & GROUT IN PLACE (INCLUDED IN THE COST OF CRC PAVEMENT)
- (E) TRANSVERSE EXPANSION JOINT WITH 1/2" DIA. CAPPED DOWELS, 18" LONG @ 12" C-C, DRILL & GROUT IN PLACE (INCLUDED IN THE COST OF CRC PAVEMENT)
- (K) LONGITUDINAL KEYED JOINT WITHOUT TIE BARS (INCLUDED IN THE COST OF CRC PAVEMENT OR PCC SHOULDERS).
- (EN) TRANSVERSE EXPANSION JOINT (NO DOWELS INCLUDED) (INCLUDED IN THE COST OF CRC PAVEMENT)

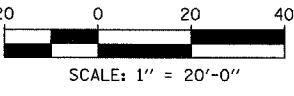
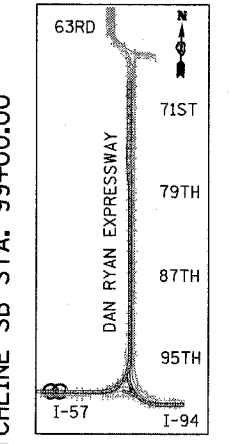

REVISIONS	
NAME	DATE

ILLINOIS DEPARTMENT OF TRANSPORTATION
**F.A.I. 94 (DAN RYAN EXPRESSWAY)
 PAVEMENT JOINTING AND ELEVATION PLAN
 SB I-57
 STA. 88+60.00 TO 99+00.00
 SHEET 1 OF 23**

SCALE: 1"=20'
 DATE: MARCH 1, 2006
 DRAWN BY: JJS
 CHECKED BY: MPG

TYLIN INTERNATIONAL

ADDENDUM 1 05/08/06

05/05/2006 04:25:26 PM

F.A.I. RTE.	SECTION	COUNTY	TOTAL SHEETS	SHEET NO.
94		COOK	764	160
STA. 88+60 (SB I-57) TO STA. 1313+00 (SB RYAN)				
FED. ROAD DIST. NO. ILLINOIS FED. AID PROJECT				
(1516.1, 1717, & 1818) R-5 62593				

- NOTES:**
- PAVEMENT ELEVATIONS GIVEN ARE AT 25' SPACING UNLESS OTHERWISE NOTED
 - ALL DEFORMED TIE BARS SHALL BE EPOXY COATED.
 - CONTRACTION JOINTS (UNDOWELED-SAWED OR GROOVED) SHALL BE PROVIDED ACROSS ALL PCC SHOULDERS. JOINT SPACING SHALL BE 15' C-C UNLESS OTHERWISE NOTED.

NOTE: ALL STATIONS GIVEN ARE REFERENCED FROM THE SB I-57 BASELINE, UNLESS OTHERWISE NOTED

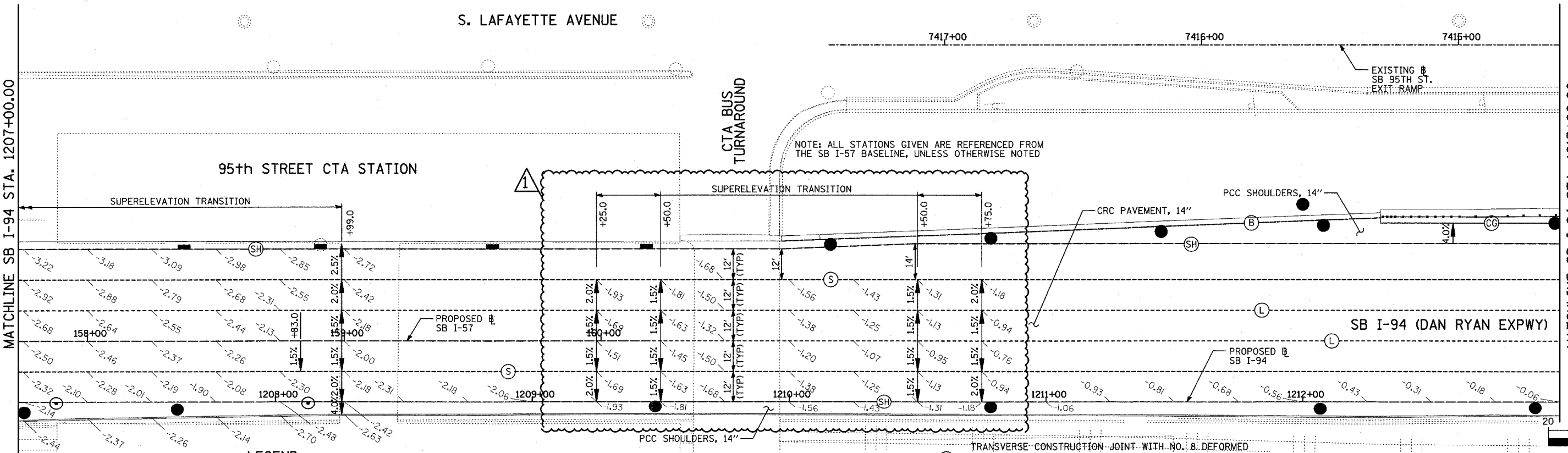
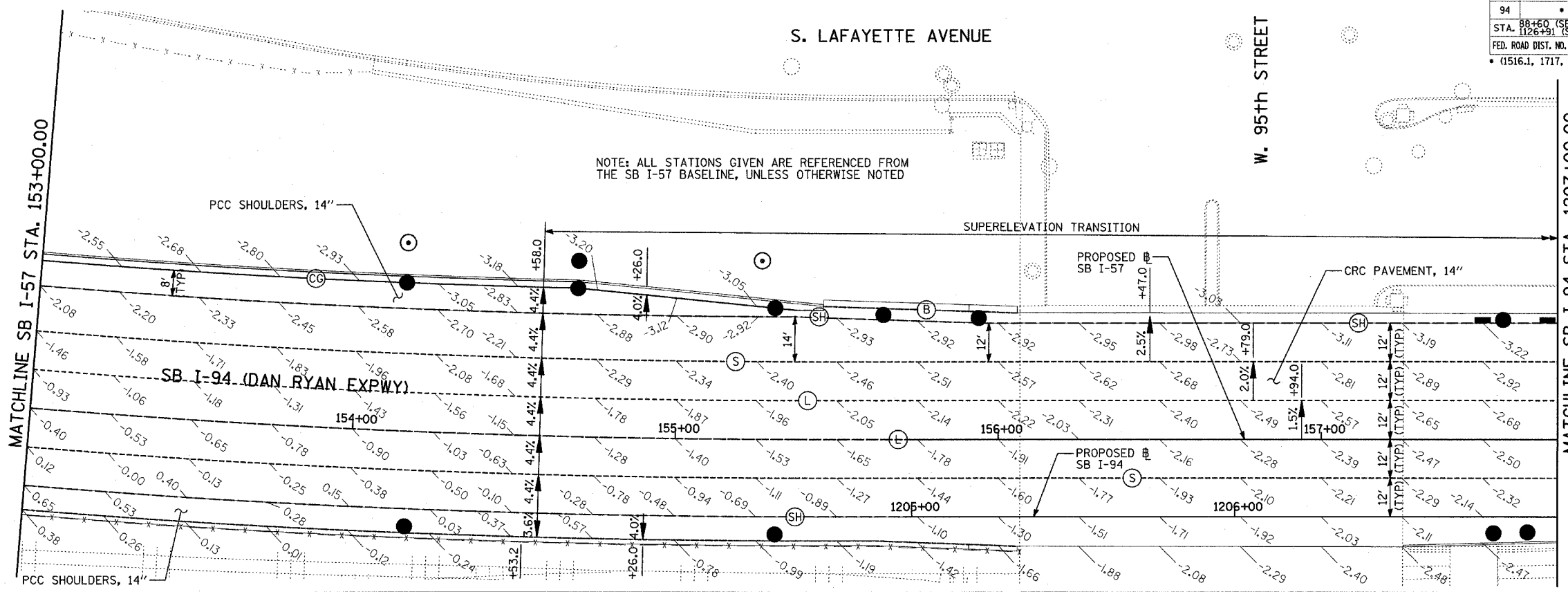

NOTE: ALL STATIONS GIVEN ARE REFERENCED FROM THE SB I-57 BASELINE, UNLESS OTHERWISE NOTED

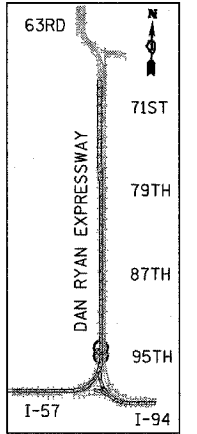

LOCATION MAP

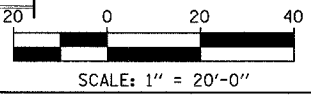

LEGEND:

- (B) LONGITUDINAL BARRIER CONSTRUCTION JOINT. SEE TYPICAL SECTION DETAILS FOR DESCRIPTION.
- (CG) CONSTRUCTION JOINT WITH NO. 6 DEFORMED TIE BAR (EPOXY COATED), 24" LONG @ 24" C-C, DRILL & GROUT IN PLACE (INCLUDED IN THE COST OF CURB & GUTTER)
- (S) SAWED LONGITUDINAL JOINT WITH NO. 6 DEFORMED TIE BAR (EPOXY COATED), 30" LONG @ 30" C-C (INCLUDED IN THE COST OF CRC PAVEMENT)
- (T) TRANSVERSE CONSTRUCTION JOINT WITH 1-1/2" DIA. DEFORMED TIE BARS (EPOXY COATED), 18" LONG @ 12" C-C, DRILL & GROUT IN PLACE (INCLUDED IN THE COST OF PCC PAVEMENT)
- (SH) LONGITUDINAL SHOULDER CONSTRUCTION JOINT WITH NO. 6 DEFORMED TIE BAR (EPOXY COATED), 24" LONG @ 24" C-C, DRILL & GROUT IN PLACE (INCLUDED IN THE COST OF PCC AND CRC PAVEMENT)
- (L) LONGITUDINAL CONSTRUCTION JOINT WITH NO. 6 DEFORMED TIE BAR (EPOXY COATED), 24" LONG @ 24" C-C, DRILL & GROUT IN PLACE (INCLUDED IN THE COST OF CRC PAVEMENT)
- (TC) TRANSVERSE CONSTRUCTION JOINT WITH NO. 8 DEFORMED TIE BAR (EPOXY COATED), 24" LONG @ 24" C-C, DRILL & GROUT IN PLACE (INCLUDED IN THE COST OF CRC PAVEMENT)
- (E) TRANSVERSE EXPANSION JOINT WITH 1/2" DIA. CAPPED DOWELS, 18" LONG @ 12" C-C, DRILL & GROUT IN PLACE (INCLUDED IN THE COST OF CRC PAVEMENT)
- (K) LONGITUDINAL KEYED JOINT WITHOUT TIE BARS (INCLUDED IN THE COST OF CRC PAVEMENT OR PCC SHOULDERS).
- (EN) TRANSVERSE EXPANSION JOINT (NO DOWELS INCLUDED) (INCLUDED IN THE COST OF CRC PAVEMENT)

REVISIONS	
NAME	DATE

ILLINOIS DEPARTMENT OF TRANSPORTATION
F.A.I. 94 (DAN RYAN EXPRESSWAY)
PAVEMENT JOINTING AND ELEVATION PLAN
 SB I-57 & SB I-94 - SB I-57 STA. 153+00.00
 TO SB I-94 STA. 1213+00.00
SHEET 9 OF 23

SCALE: 1"=20'
 DATE: MARCH 1, 2006
 DRAWN BY: JJS
 CHECKED BY: MPG

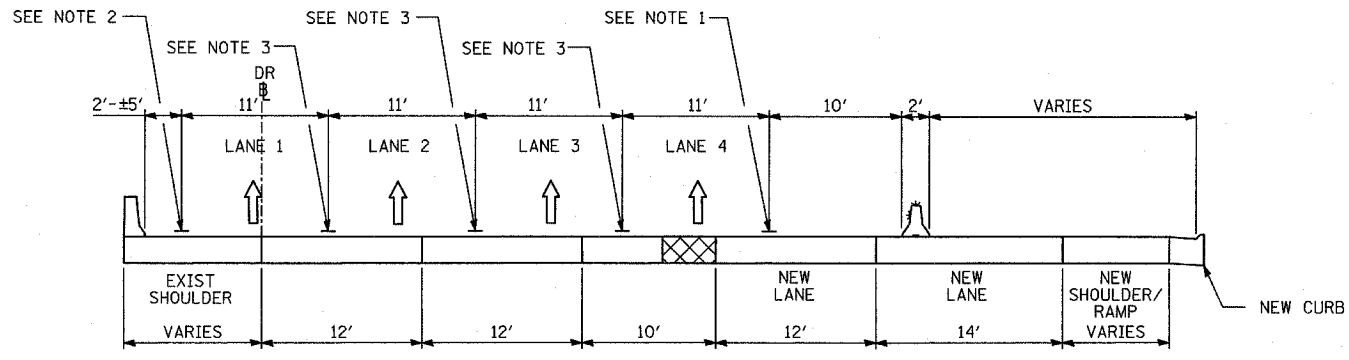

K-K

WINTER LANE CONFIGURATION: SB I-94 DAN RYAN; STA. 1217+27 TO 1313+00

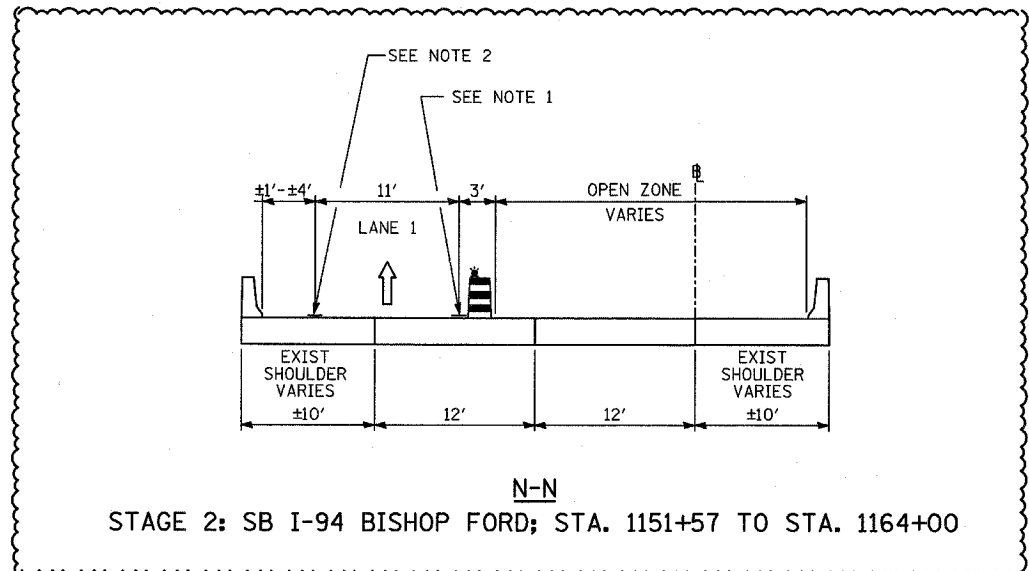

N-N

STAGE 2: SB I-94 BISHOP FORD; STA. 1151+57 TO STA. 1164+00

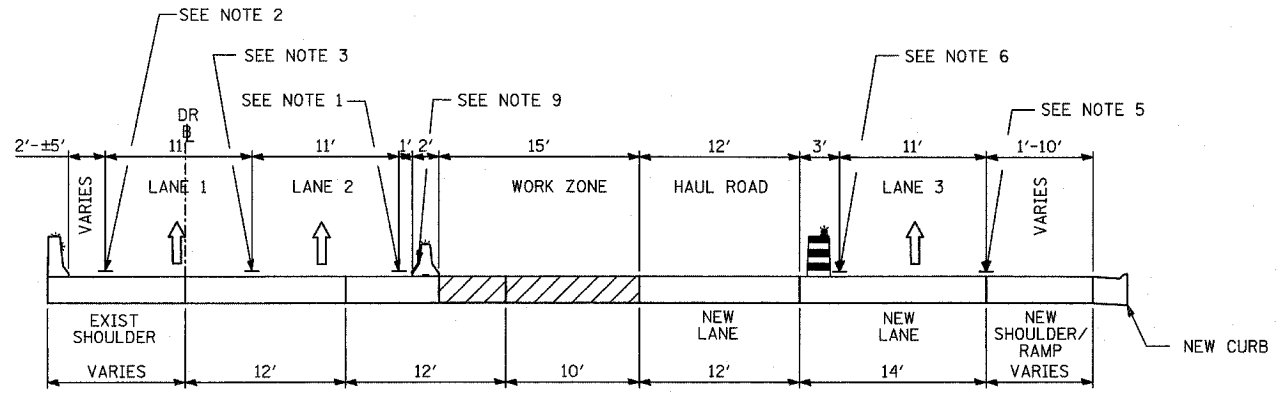

L-L

STAGE 2: SB I-94 DAN RYAN; STA. 1216+60 TO STA. 1270+00
 STAGE 2: SB I-94 DAN RYAN; STA. 1282+51 TO STA. 1313+00
 STAGE 2A: SB I-94 DAN RYAN; STA. 1216+60 TO STA. 1260+00
 STAGE 2A: SB I-94 DAN RYAN; STA. 1272+51 TO STA. 1313+00

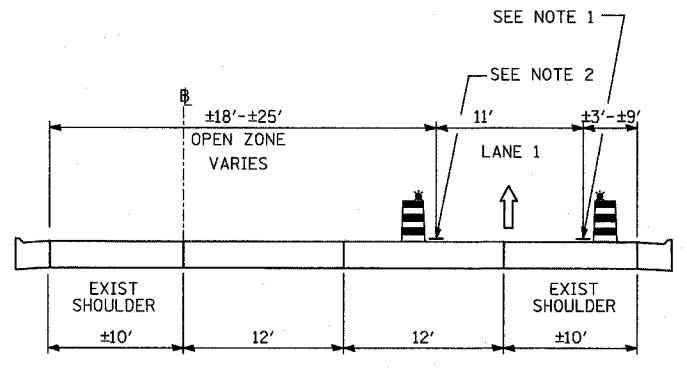

O-O

STAGE 2: EB CROSS CONNECTOR; STA. 415+06 TO STA. 421+00

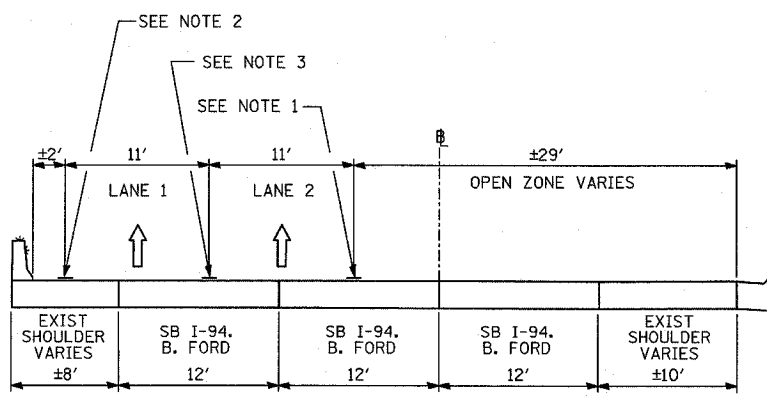

M-M

STAGE 2: SB I-94 BISHOP FORD; STA. 1137+07 TO STA. 1142+61

- NOTE 1 - EPOXY PAVEMENT MARKING-LINE 4" (WHITE)
- NOTE 2 - EPOXY PAVEMENT MARKING-LINE 4" (YELLOW)
- NOTE 3 - EPOXY PAVEMENT MARKING-SKIP-DASH 5" (WHITE), 10' LINE WITH 30' SPACE
- NOTE 4 - EPOXY PAVEMENT MARKING LINE 8" (WHITE)
- NOTE 5 - PAVEMENT MARKING TAPE, TYPE III 4" LINE (WHITE)
- NOTE 6 - PAVEMENT MARKING TAPE, TYPE III 4" LINE (YELLOW)
- NOTE 7 - PAVEMENT MARKING TAPE, TYPE III 5" SKIP-DASH (WHITE), 10' LINE WITH 30' SPACE
- NOTE 8 - PAVEMENT MARKING TAPE, TYPE III 8" LINE (WHITE)
- NOTE 9 - TEMPORARY PAVEMENT MARKING-LINE 6" (WHITE)
- NOTE 10 - TEMPORARY PAVEMENT MARKING-LINE 6" (YELLOW)

LEGEND:

- TEMPORARY CONCRETE BARRIER (WITH REFLECTORS ON TOP AND SIDE FACING TRAFFIC)
- TRAFFIC MOVEMENT
- DRUM WITH MONO-DIRECTIONAL STEADY BURNING LIGHT
- SINGLE-FACE CONCRETE BARRIER, 32"
- SINGLE-FACE CONCRETE BARRIER, 32" (WITH REFLECTORS ON TOP AND SIDE FACING TRAFFIC)
- PAVEMENT REMOVAL AREA
- TEMPORARY PAVEMENT

* ALL NOT TYPICAL SECTIONS ARE DRAWN IN THE DIRECTION OF TRAFFIC

REVISIONS	
NAME	DATE

ILLINOIS DEPARTMENT OF TRANSPORTATION
 F.A.I. 94 (DAN RYAN EXPRESSWAY)
 GENERAL NOTES
 CONSTRUCTION STAGING NOTES
 MAINTENANCE OF TRAFFIC DETAILS
 SHEET 4 OF 12

SCALE: NO SCALE DRAWN BY: RTM
 DATE: MARCH 1, 2006 CHECKED BY: TGB

ADDENDUM 1 05/08/06

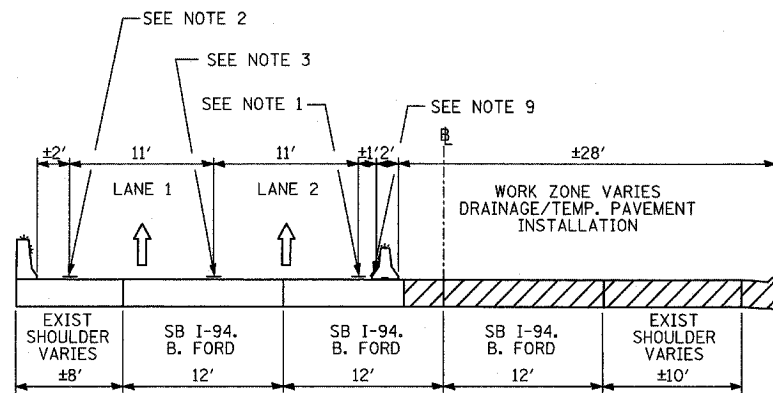

U-U

STAGE 3A: SB I-94 BISHOP FORD; STA. 1133+92 TO STA. 1143+07

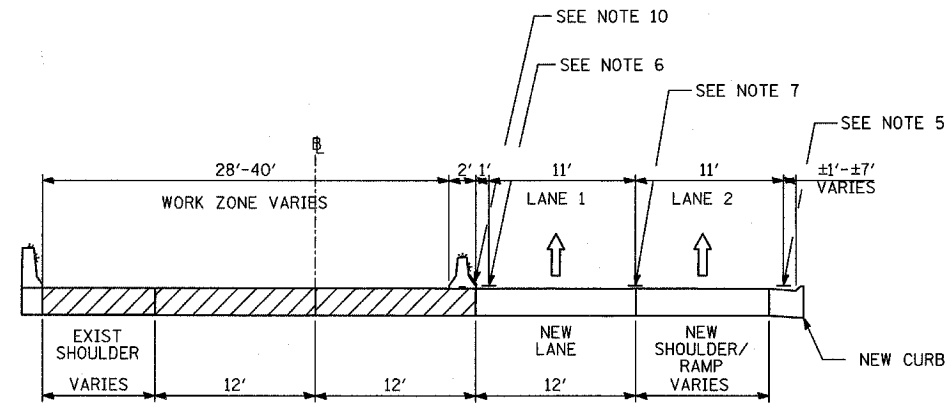

X-X

STAGE 3B: SB I-57; STA. 89+60 TO STA. 103+98

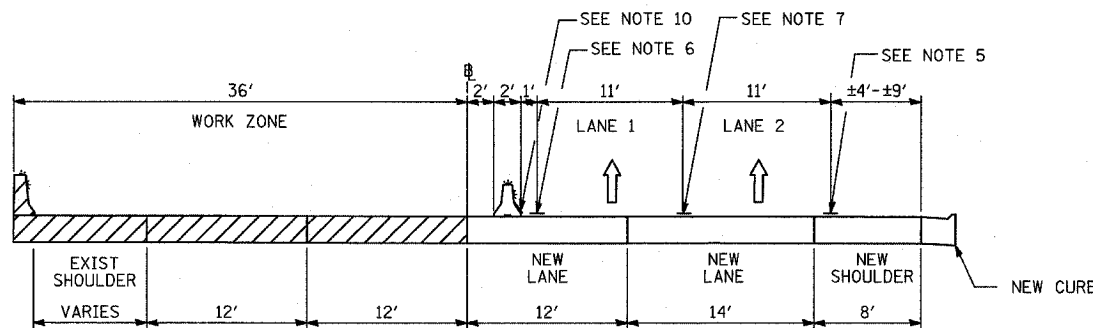

Y-Y

STAGE 3B: SB I-57; STA. 107+16 TO STA. 121+36
 STAGE 3C: SB I-57; STA. 107+16 TO STA. 121+36
 STAGE 3D: SB I-57; STA. 107+16 TO STA. 121+36

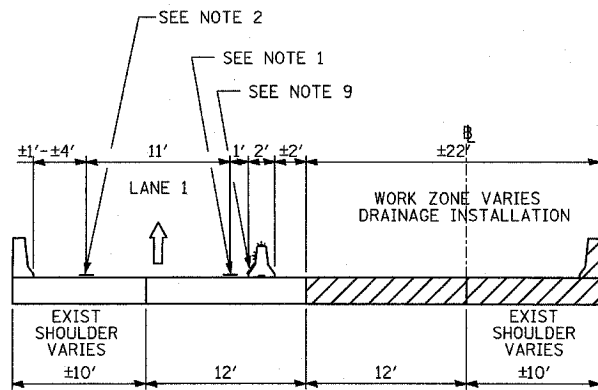

V-V

STAGE 3A: SB I-94 BISHOP FORD; STA. 1151+57 TO STA. 1164+00

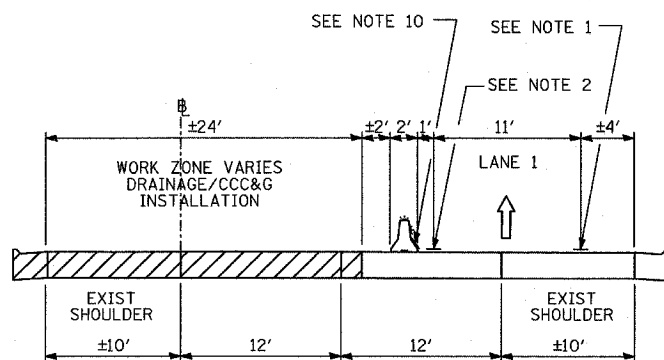

W-W

STAGE 3A: EB CROSS CONNECTOR; STA. 415+06 TO STA. 421+81

- NOTE 1 - EPOXY PAVEMENT MARKING-LINE 4" (WHITE)
- NOTE 2 - EPOXY PAVEMENT MARKING-LINE 4" (YELLOW)
- NOTE 3 - EPOXY PAVEMENT MARKING-SKIP-DASH 5" (WHITE), 10' LINE WITH 30' SPACE
- NOTE 4 - EPOXY PAVEMENT MARKING LINE 8" (WHITE)
- NOTE 5 - PAVEMENT MARKING TAPE, TYPE III 4" LINE (WHITE)
- NOTE 6 - PAVEMENT MARKING TAPE, TYPE III 4" LINE (YELLOW)
- NOTE 7 - PAVEMENT MARKING TAPE, TYPE III 5" SKIP-DASH (WHITE), 10' LINE WITH 30' SPACE
- NOTE 8 - PAVEMENT MARKING TAPE, TYPE III 8" LINE (WHITE)
- NOTE 9 - TEMPORARY PAVEMENT MARKING-LINE 6" (WHITE)
- NOTE 10 - TEMPORARY PAVEMENT MARKING-LINE 6" (YELLOW)

LEGEND:

- TEMPORARY CONCRETE BARRIER (WITH REFLECTORS ON TOP AND SIDE FACING TRAFFIC)
- TRAFFIC MOVEMENT
- DRUM WITH MONO-DIRECTIONAL STEADY BURNING LIGHT
- SINGLE-FACE CONCRETE BARRIER, 32"
- SINGLE-FACE CONCRETE BARRIER, 32" (WITH REFLECTORS ON TOP AND SIDE FACING TRAFFIC)
- PAVEMENT REMOVAL AREA
- TEMPORARY PAVEMENT

* ALL NOT TYPICAL SECTIONS ARE DRAWN IN THE DIRECTION OF TRAFFIC

REVISIONS	
NAME	DATE

ILLINOIS DEPARTMENT OF TRANSPORTATION
 F.A.I. 94 (DAN RYAN EXPRESSWAY)
 GENERAL NOTES
 CONSTRUCTION STAGING NOTES
 MAINTENANCE OF TRAFFIC DETAILS
 SHEET 6 OF 12

SCALE: NO SCALE DRAWN BY: RTM
 DATE: MARCH 1, 2006 CHECKED BY: TGB

ADDENDUM 1 05/08/06

SIGNS ON THIS SHEET SHALL BE PAID FOR AS "TRAFFIC CONTROL AND PROTECTION FOR DETOUR ROUTE". 1 LUMP SUM.

LEGEND

- M4-5 (30" X 15")
- M3-2 (24" X 12")
- M4-8 (24" X 12")
- M1-1 (24" X 24")
- M20-2 (36" X 36")
- M4-9L (30" X 24")
- M4-9R (30" X 24")
- M6-2 (21" X 15")
- M6-3 (21" X 15")
- M5-1R (21" X 15")
- M5-1L (21" X 15")
- DETOUR ROUTE
- CLOSED TO TRAFFIC
- M4-8a (24" X 18")
- PERSON DIRECTING TRAFFIC

PORTABLE CHANGEABLE MESSAGE SIGNS SHALL BE PLACED IN ADVANCE OF THE DETOUR AS DETAILED IN THE SPECIAL PROVISIONS.

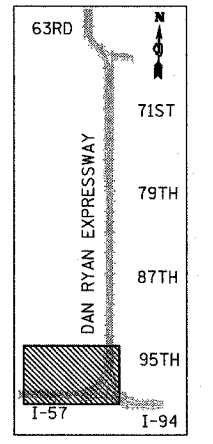
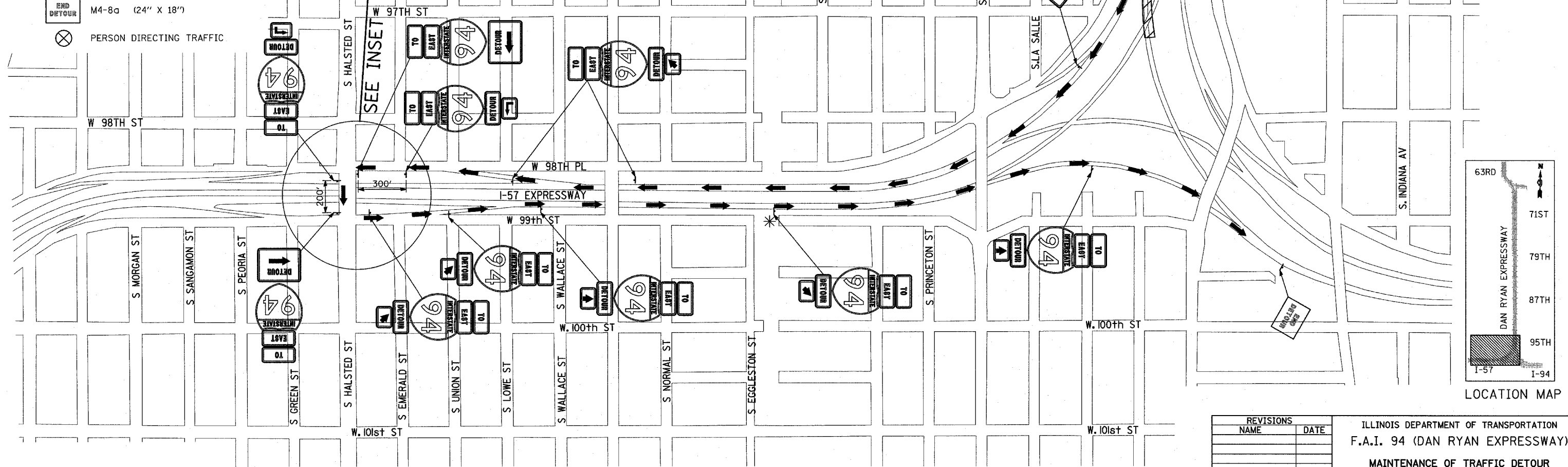
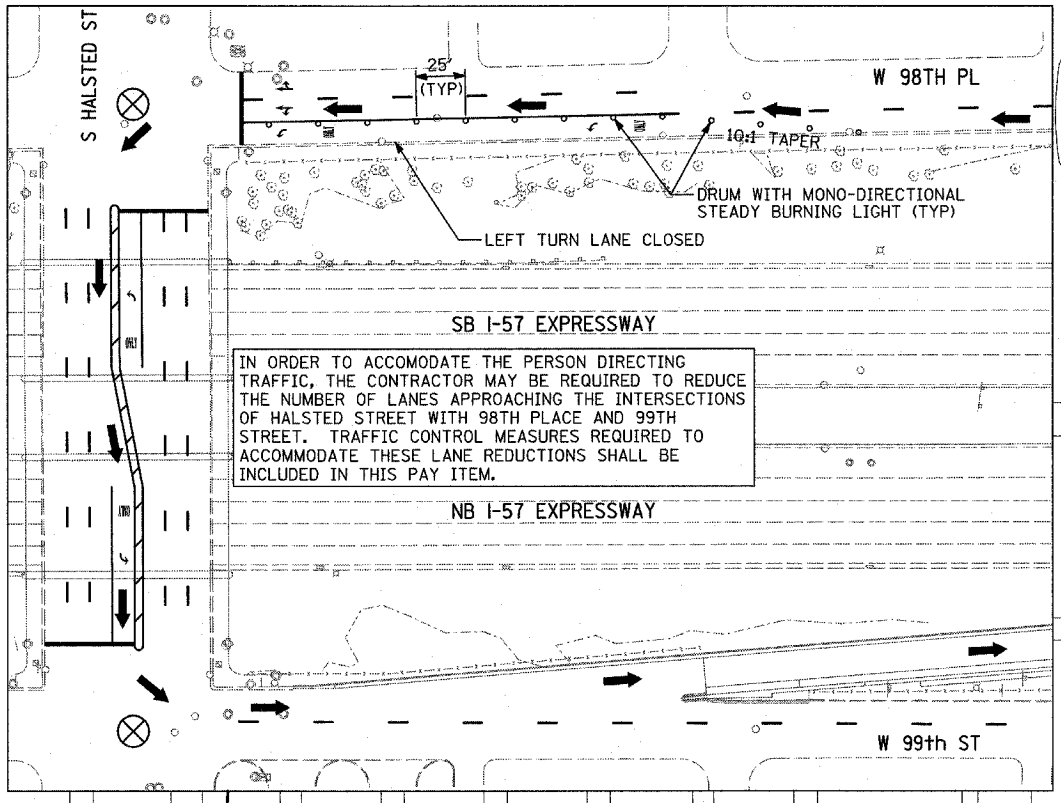

TYLIN INTERNATIONAL

FOR INFORMATION ONLY

* LOCATION OF THESE SIGNS WILL VARY TO REFLECT THE CURRENT MAINTENANCE OF TRAFFIC CONFIGURATION. DETOUR TRAILBLAZER SIGNS ARE TO BE PLACED ADJACENT TO THE START OF THE GORE.

REVISIONS	
NAME	DATE

ILLINOIS DEPARTMENT OF TRANSPORTATION
 F.A.I. 94 (DAN RYAN EXPRESSWAY)
 MAINTENANCE OF TRAFFIC DETOUR
 SOUTHBOUND I-94 (BISHOP FORD FREEWAY)
 CLOSURE FOR BOX BEAMS REPLACEMENT

SCALE: NO SCALE
 DATE: MAY 8, 2006

DRAWN BY: JJS
 CHECKED BY: TGB

NEW SHEET 05/08/06

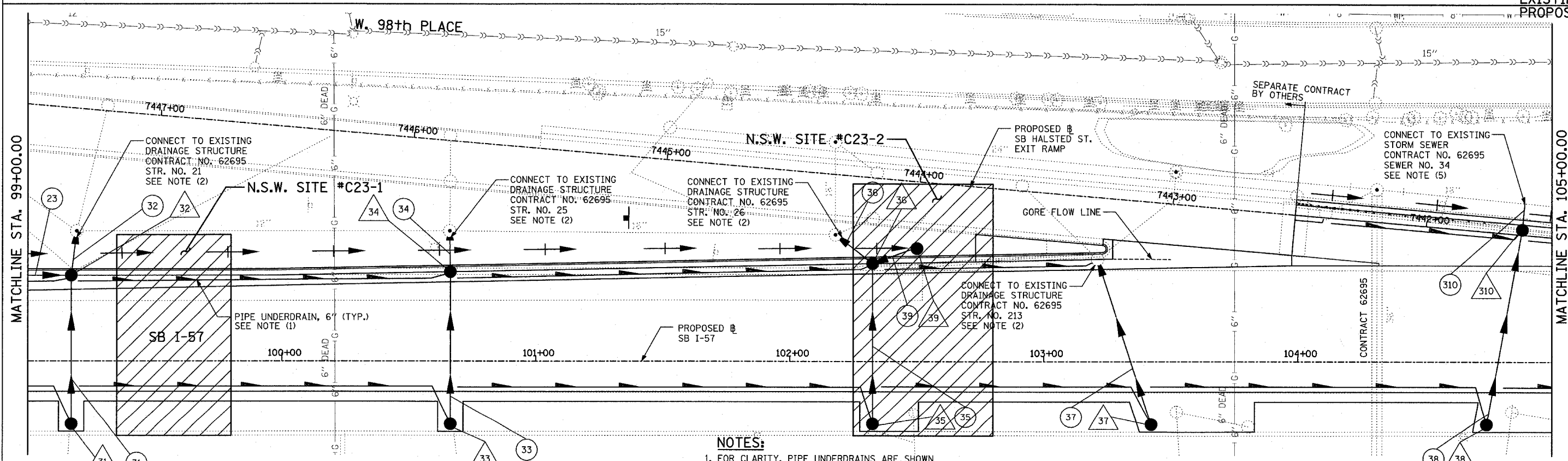
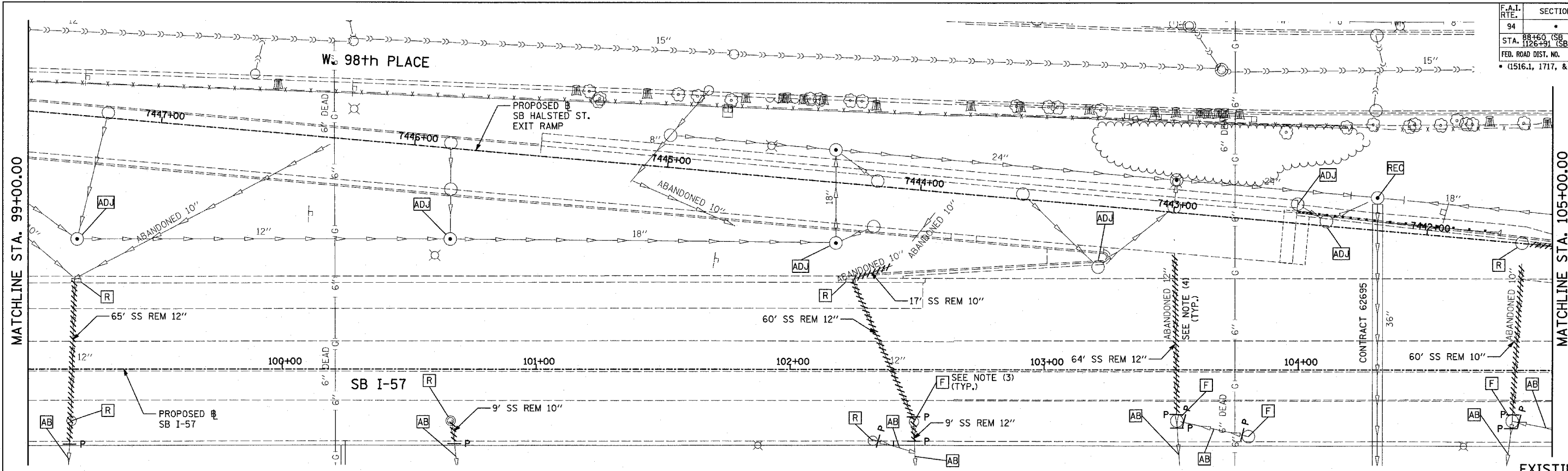

EXISTING CONDITIONS
PROPOSED IMPROVEMENTS

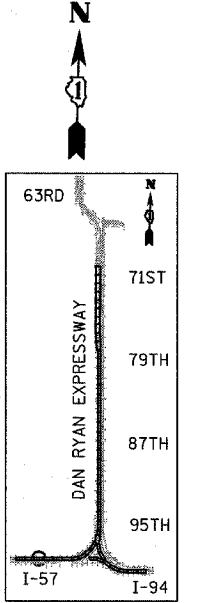

LEGEND:

	EXISTING COMBINED SEWER		SEWER PLUG
	PROPOSED STORM SEWER NUMBER (X=SHEET NO., Y=PIPE NO.)		FIELD VERIFY
	PROPOSED STRUCTURE NUMBER (X=SHEET NO., Y=STRUCTURE NO.)		UTILITY REMOVAL
	PIPE STUBOUT TO BE PLUGGED		PROPOSED CATCH BASIN CONSTRUCTED IN CONCURRENT CONTRACT 62304
			PROPOSED STORM SEWER CONSTRUCTED IN CONCURRENT CONTRACT 62304

- NOTES:**
- FOR CLARITY, PIPE UNDERDRAINS ARE SHOWN OFFSET FROM THEIR PROPOSED LOCATIONS. FOR DETAILED PLACEMENT, SEE SHEET "PIPE UNDERDRAINS DETAIL."
 - CORE DRILL AND CONNECT TO EXISTING DRAINAGE STRUCTURE. CONNECTION COST SHALL BE INCLUDED IN THE COST TO CONSTRUCT THE STORM SEWER.
 - COST TO REMOVE FRAME AND GRATE SHALL BE INCLUDED IN THE COST TO FILL THE DRAINAGE STRUCTURE.
 - SEWERS INDICATED AS SUCH WERE ABANDONED UNDER A PREVIOUS CONTRACT AND WILL BE REMOVED UNDER CURRENT CONTRACT.

5. COST SHALL NOT BE PAID FOR SEPARATELY BUT INCLUDED IN COST OF SEWER INSTALLATION.

NSW - NON SPECIAL WASTE SITES ADDED TO SHEET

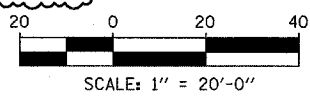

SHEET 3 OF 65

REVISIONS	
NAME	DATE

ILLINOIS DEPARTMENT OF TRANSPORTATION
F.A.I. 94 (DAN RYAN EXPRESSWAY)
DRAINAGE AND UTILITY PLANS
SB I-57
SB I-57 STA. 99+00.00 TO 105+00.00

SCALE: 1"=20'
DATE: MARCH 1, 2006

DRAWN BY: NSB
CHECKED BY: DA

TYLIN INTERNATIONAL

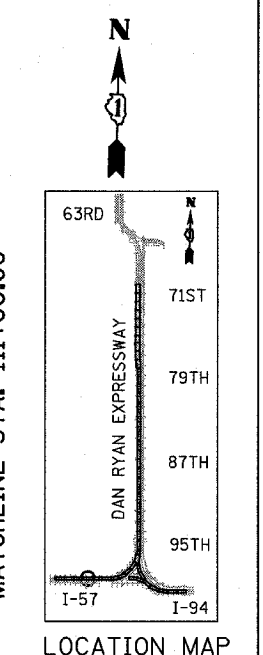
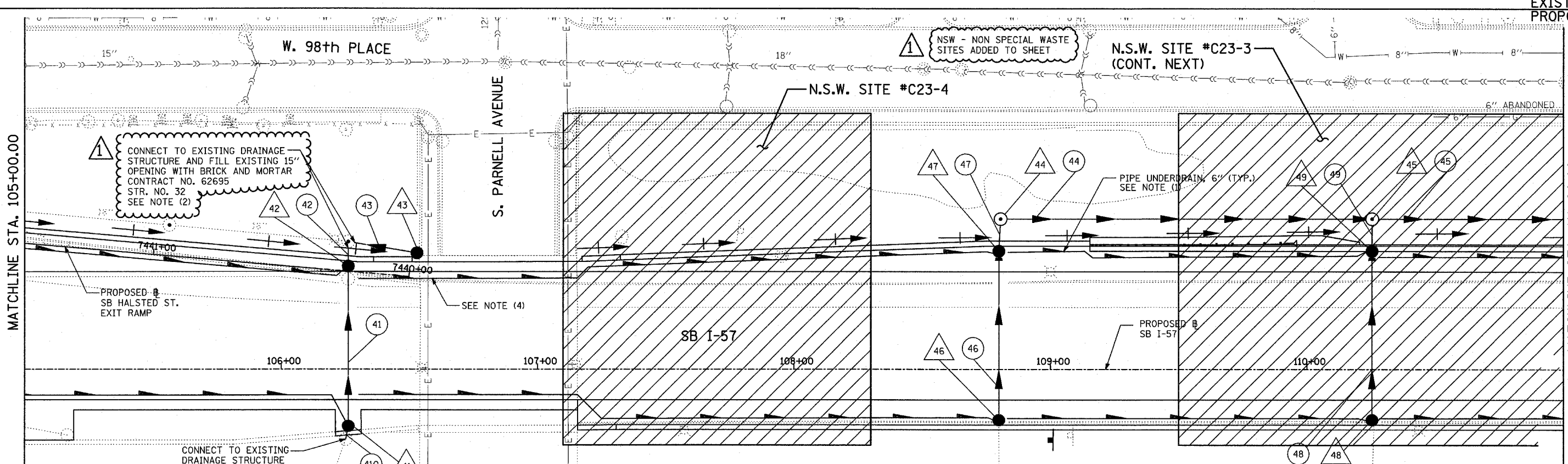
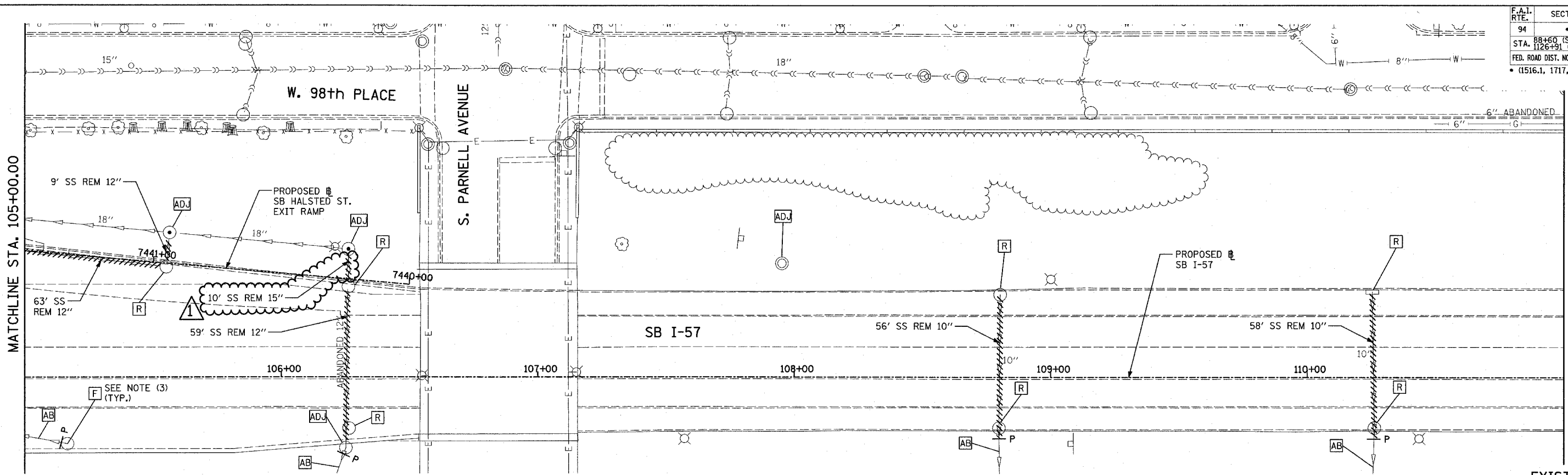

LEGEND:

- EXISTING COMBINED SEWER
- (XY) PROPOSED STORM SEWER NUMBER (X=SHEET NO., Y=PIPE NO.)
- (XY) PROPOSED STRUCTURE NUMBER (X=SHEET NO., Y=STRUCTURE NO.)
- PIPE STUBOUT TO BE PLUGGED
- P SEWER PLUG
- F.V. UTILITY VERIFY
- UTILITY REMOVAL
- PROPOSED CATCH BASIN CONSTRUCTED IN CONCURRENT CONTRACT 62304
- PROPOSED STORM SEWER CONSTRUCTED IN CONCURRENT CONTRACT 62304

NOTES:

- FOR CLARITY, PIPE UNDERDRAINS ARE SHOWN OFFSET FROM THEIR PROPOSED LOCATIONS. FOR DETAILED PLACEMENT, SEE SHEET "PIPE UNDERDRAINS DETAIL."
- CORE DRILL AND CONNECT TO EXISTING DRAINAGE STRUCTURE. CONNECTION COST SHALL BE INCLUDED IN THE COST TO CONSTRUCT THE STORM SEWER.
- COST TO REMOVE FRAME AND GRATE SHALL BE INCLUDED IN THE COST TO FILL THE DRAINAGE STRUCTURE.
- PROPOSED PIPE UNDERDRAIN SYSTEM LOCATION SHALL BE COORDINATED WITH PROPOSED ELECTRICAL DUCT BANK AND EXISTING FOOTING. SEE TYPICAL SECTIONS AND DETAILS FOR OVERPASS FOOTINGS.

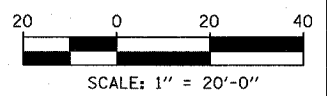

SHEET 4 OF 65

REVISIONS	
NAME	DATE

ILLINOIS DEPARTMENT OF TRANSPORTATION
F.A.I. 94 (DAN RYAN EXPRESSWAY)
DRAINAGE AND UTILITY PLANS
SB I-57
SB I-57 STA. 105+00.00 TO 111+00.00

SCALE: 1"=20'
 DATE: MARCH 1, 2006

DRAWN BY: NSB
 CHECKED BY: DA

F.A.I. RTE.	SECTION	COUNTY	TOTAL SHEETS	SHEET NO.
94		COOK	764	285
STA. 1126+91 (SB FORD) TO STA. 1313+00 (SB RYAN)				
FED. ROAD DIST. NO. ILLINOIS FED. AID PROJECT				
(1516.1, 1717, & 1818) R-5				
				62593

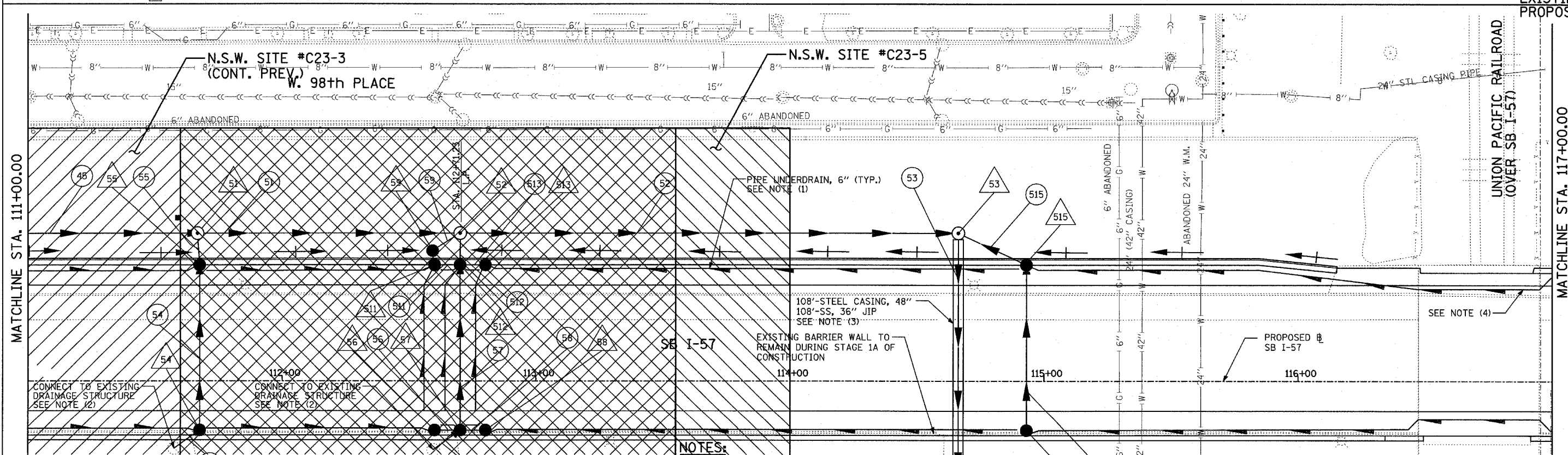
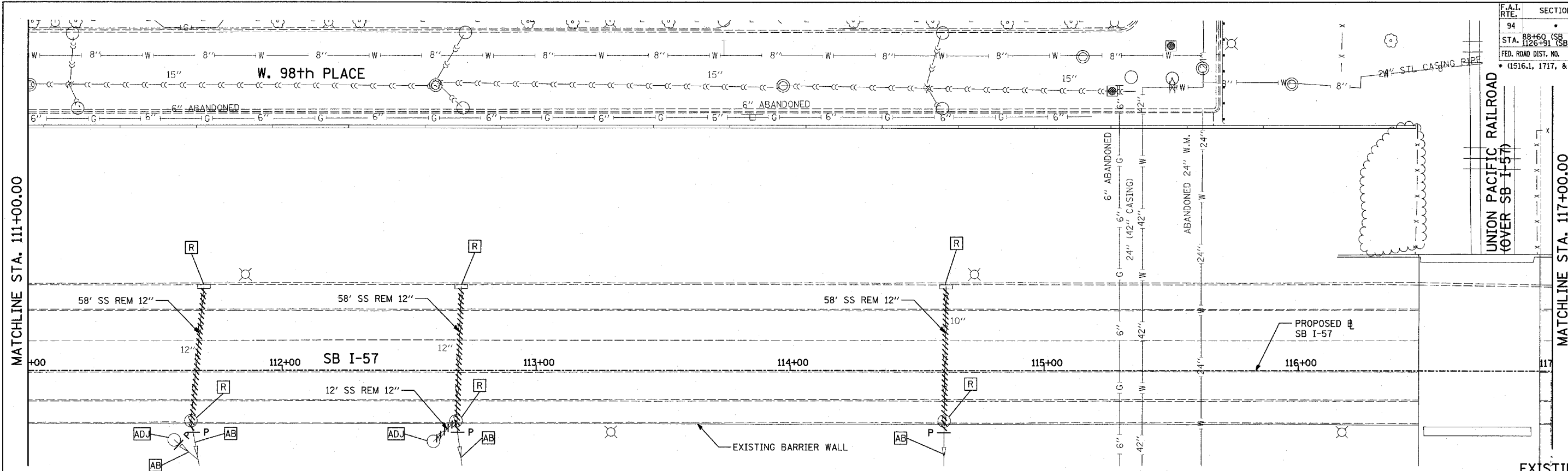

EXISTING CONDITIONS
PROPOSED IMPROVEMENTS

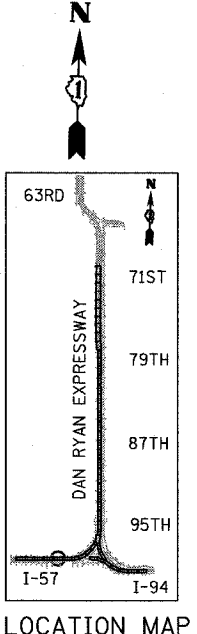

LOCATION MAP

MATCHLINE STA. 111+00.00

MATCHLINE STA. 117+00.00

TYLIN INTERNATIONAL

LEGEND:

	EXISTING COMBINED SEWER		SEWER PLUG
	PROPOSED STORM SEWER NUMBER (X=SHEET NO., Y=PIPE NO.)		FIELD VERIFY
	PROPOSED STRUCTURE NUMBER (X=SHEET NO., Y=STRUCTURE NO.)		UTILITY REMOVAL
	PIPE STUBOUT TO BE PLUGGED		PROPOSED CATCH BASIN CONSTRUCTED IN CONCURRENT CONTRACT 62304
			PROPOSED STORM SEWER CONSTRUCTED IN CONCURRENT CONTRACT 62304

- NOTES:**
- FOR CLARITY, PIPE UNDERDRAINS ARE SHOWN OFFSET FROM THEIR PROPOSED LOCATIONS. FOR DETAILED PLACEMENT, SEE SHEET "PIPE UNDERDRAINS DETAIL."
 - CORE DRILL AND CONNECT TO EXISTING DRAINAGE STRUCTURE. CONNECTION COST SHALL BE INCLUDED IN THE COST TO CONSTRUCT THE STORM SEWER.
 - THE PROPOSED 36" JIP SEWER SHALL BE INSTALLED PRIOR TO ANY OTHER SEWER INSTALLATION.
 - PROPOSED PIPE UNDERDRAIN SYSTEM LOCATION SHALL BE COORDINATED WITH PROPOSED ELECTRICAL DUCT BANK AND EXISTING FOOTING. SEE TYPICAL SECTIONS AND DETAILS FOR OVERPASS FOOTINGS.

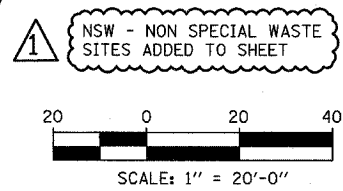

SHEET 5 OF 65

REVISIONS	
NAME	DATE

ADDENDUM 1 - NSW 05/08/06

ILLINOIS DEPARTMENT OF TRANSPORTATION
F.A.I. 94 (DAN RYAN EXPRESSWAY)
DRAINAGE AND UTILITY PLANS
SB I-57
SB I-57 STA. 111+00.00 TO 117+00.00

SCALE: 1"=20'
DATE: MARCH 1, 2006

DRAWN BY: NSB
CHECKED BY: DA

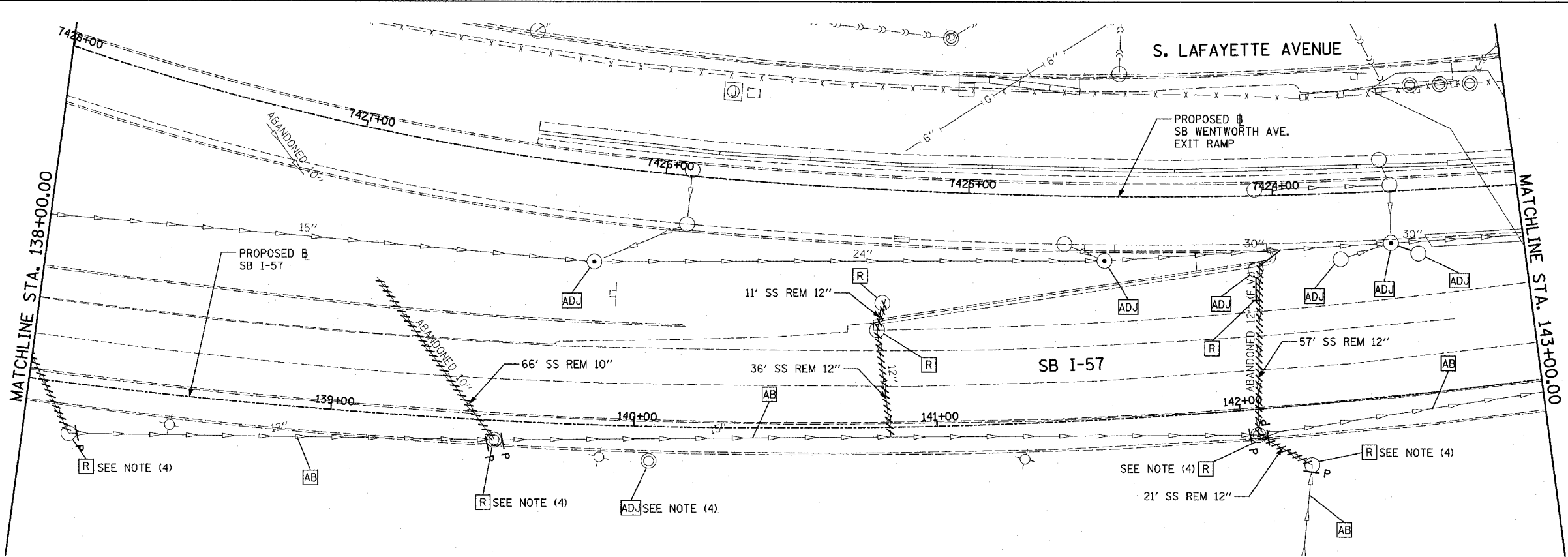

EXISTING CONDITIONS
PROPOSED IMPROVEMENTS

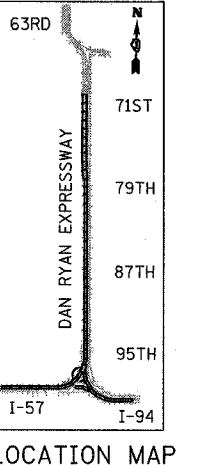
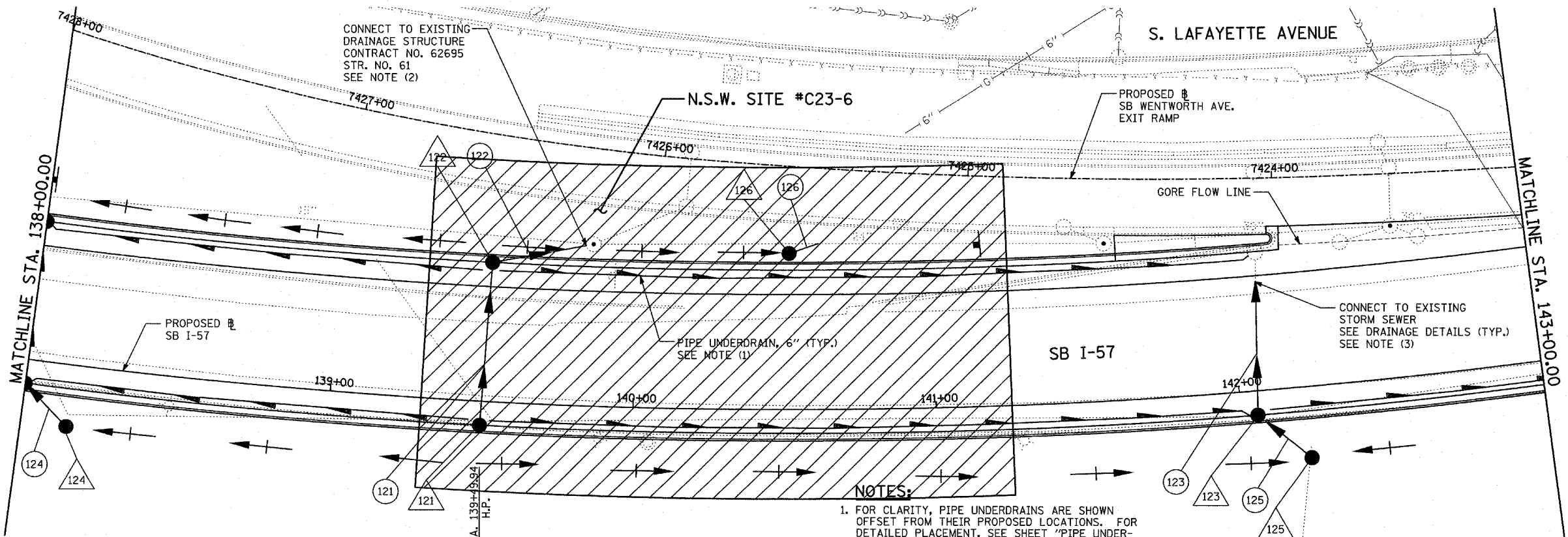

- NOTES:**
1. FOR CLARITY, PIPE UNDERDRAINS ARE SHOWN OFFSET FROM THEIR PROPOSED LOCATIONS. FOR DETAILED PLACEMENT, SEE SHEET "PIPE UNDERDRAINS DETAIL."
 2. CORE DRILL AND CONNECT TO EXISTING DRAINAGE STRUCTURE. CONNECTION COST SHALL BE INCLUDED IN THE COST TO CONSTRUCT THE STORM SEWER.
 3. COST SHALL NOT BE PAID FOR SEPARATELY BUT INCLUDED IN COST OF SEWER INSTALLATION.
 4. STRUCTURES TO BE ADJUSTED DURING STAGE 1 OF CONSTRUCTION TO MAINTAIN SURFACE DRAINAGE. THIS COST SHALL BE PAID FOR SEPARATELY AND INCLUDED IN THE SUMMARY OF QUANTITIES.

- LEGEND:**
- EXISTING COMBINED SEWER
 - (XY) PROPOSED STORM SEWER NUMBER (X=SHEET NO., Y=PIPE NO.)
 - (XY) PROPOSED STRUCTURE NUMBER (X=SHEET NO., Y=STRUCTURE NO.)
 - S- PIPE STUBOUT TO BE PLUGGED
 - P SEWER PLUG
 - F.V. FIELD VERIFY
 - ////// UTILITY REMOVAL
 - PROPOSED CATCH BASIN CONSTRUCTED IN CONCURRENT CONTRACT 62304
 - PROPOSED STORM SEWER CONSTRUCTED IN CONCURRENT CONTRACT 62304

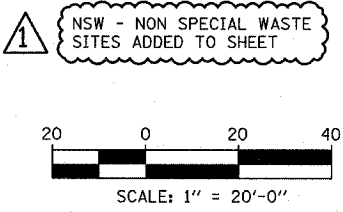

SHEET 12 OF 65

REVISIONS	
NAME	DATE

ILLINOIS DEPARTMENT OF TRANSPORTATION
F.A.I. 94 (DAN RYAN EXPRESSWAY)
DRAINAGE AND UTILITY PLANS
SB I-57
STA. 138+00.00 TO STA. 143+00.00

SCALE: 1"=20'
DATE: MARCH 1, 2006

DRAWN BY: NSB
CHECKED BY: DA

TYLIN INTERNATIONAL

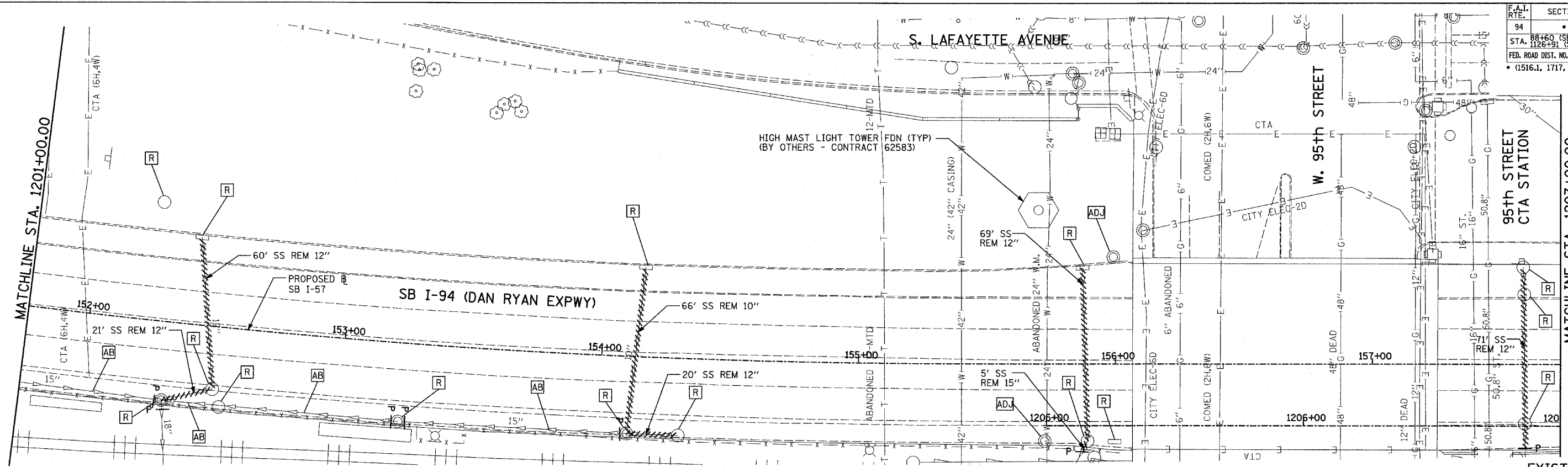

EXISTING CONDITIONS
PROPOSED IMPROVEMENTS

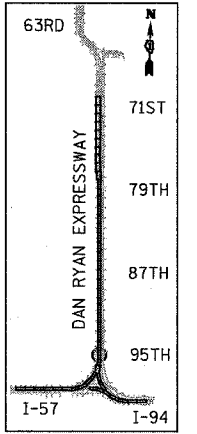
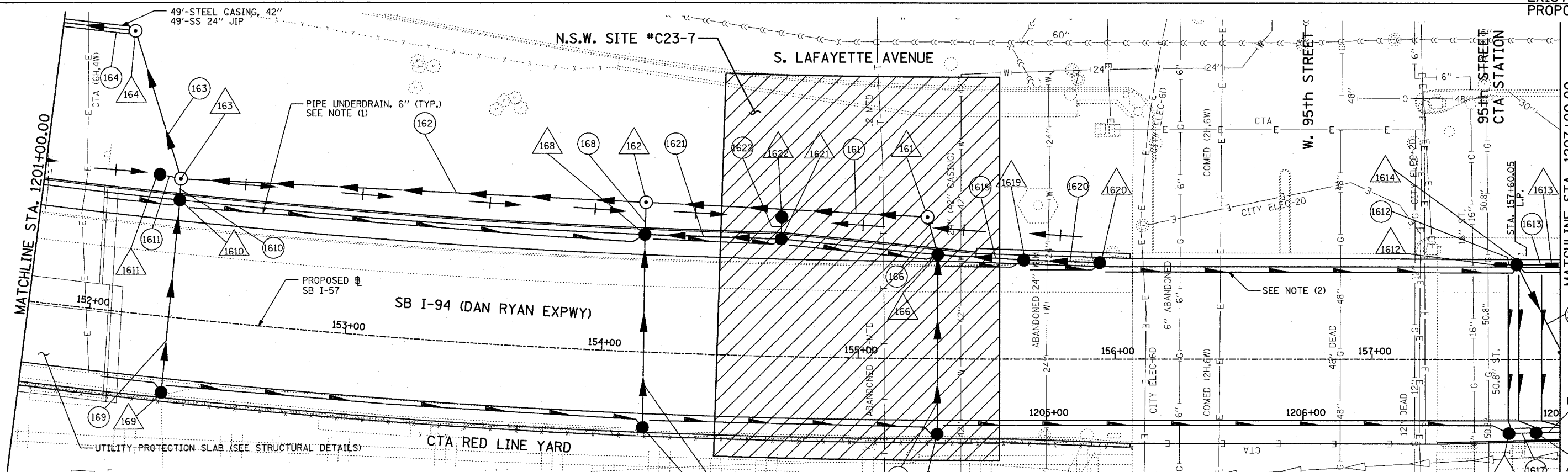

LOCATION MAP

LEGEND:

- EXISTING COMBINED SEWER
- PROPOSED STORM SEWER NUMBER (X=SHEET NO., Y=PIPE NO.)
- PROPOSED STRUCTURE NUMBER (X=SHEET NO., Y=STRUCTURE NO.)
- PIPE STUBOUT TO BE PLUGGED
- SEWER PLUG
- F.V. FIELD VERIFY
- UTILITY REMOVAL
- PROPOSED CATCH BASIN CONSTRUCTED IN CONCURRENT CONTRACT 62304
- PROPOSED STORM SEWER CONSTRUCTED IN CONCURRENT CONTRACT 62304

NOTES:

- FOR CLARITY, PIPE UNDERDRAINS ARE SHOWN OFFSET FROM THEIR PROPOSED LOCATIONS. FOR DETAILED PLACEMENT, SEE SHEET "PIPE UNDERDRAINS DETAIL."
- PROPOSED PIPE UNDERDRAIN SYSTEM LOCATION SHALL BE COORDINATED WITH PROPOSED ELECTRICAL DUCT BANK AND EXISTING FOOTING. SEE TYPICAL SECTIONS AND DETAILS FOR OVERPASS FOOTINGS.

NSW - NON SPECIAL WASTE SITES ADDED TO SHEET

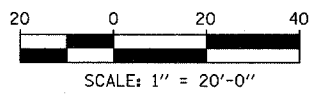

REVISIONS	
NAME	DATE

ILLINOIS DEPARTMENT OF TRANSPORTATION
F.A.I. 94 (DAN RYAN EXPRESSWAY)
DRAINAGE AND UTILITY PLANS
SB I-94 (DAN RYAN EXPRESSWAY)
SB I-94 STA. 1201+00.00 TO 1207+00.00

SCALE: 1"=20'
DATE: MARCH 1, 2006
DRAWN BY: NSB
CHECKED BY: DA

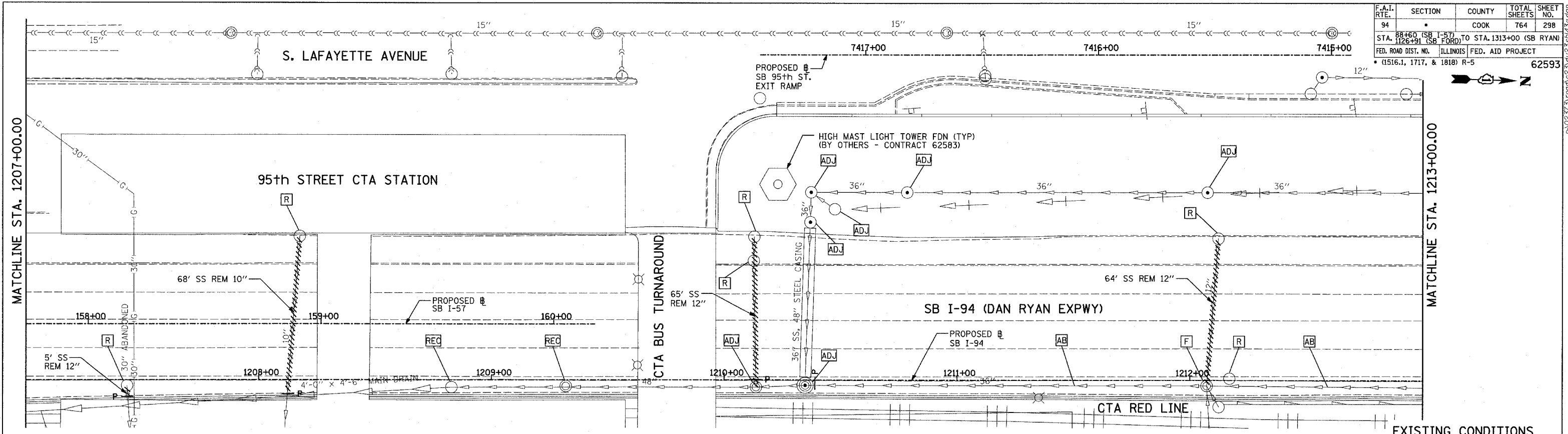

EXISTING CONDITIONS
PROPOSED IMPROVEMENTS

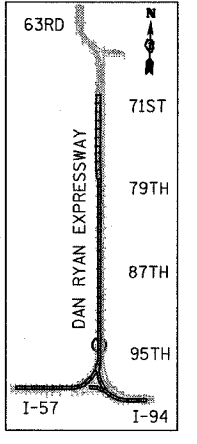
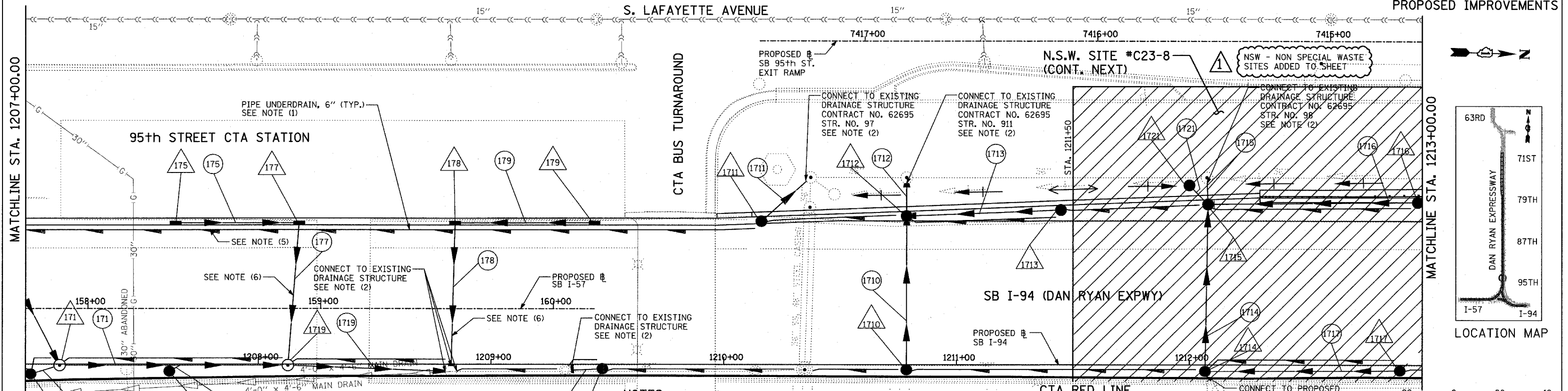

NOTES:

- FOR CLARITY, PIPE UNDERDRAINS ARE SHOWN OFFSET FROM THEIR PROPOSED LOCATIONS. FOR DETAILED PLACEMENT, SEE SHEET "PIPE UNDERDRAINS DETAIL."
- CORE DRILL AND CONNECT TO EXISTING DRAINAGE STRUCTURE. CONNECTION COST SHALL BE INCLUDED IN THE COST TO CONSTRUCT THE STORM SEWER.
- COST SHALL NOT BE PAID FOR SEPARATELY BUT INCLUDED IN COST OF SEWER INSTALLATION.
- ALL CONNECTIONS TO EXISTING SEWER OR STRUCTURE ALONG CTA SHALL BE FIELD VERIFIED PRIOR TO INSTALLATION AND COORDINATED WITH CTA CONSTRUCTION. COST SHALL BE INCLUDED IN THE COST TO CONSTRUCT THE DRAINAGE STRUCTURE.
- PROPOSED PIPE UNDERDRAIN SYSTEM LOCATION SHALL BE COORDINATED WITH PROPOSED ELECTRICAL DUCT BANK AND EXISTING FOOTING. SEE TYPICAL SECTIONS AND DETAILS FOR OVERPASS FOOTINGS.
- INSTALL 45° BEND PAST THE EXISTING FOOTING TO LOWER SEWER BELOW PROPOSED 24" GRANULAR SUBBASE. COST SHALL BE INCLUDED IN THE COST TO CONSTRUCT THE STORM SEWER.

LEGEND:

- EXISTING COMBINED SEWER
- PROPOSED STORM SEWER NUMBER (X=SHEET NO., Y=PIPE NO.)
- PROPOSED STRUCTURE NUMBER (X=SHEET NO., Y=STRUCTURE NO.)
- PIPE STUBOUT TO BE PLUGGED
- SEWER PLUG
- FIELD VERIFY
- UTILITY REMOVAL
- PROPOSED CATCH BASIN CONSTRUCTED IN CONCURRENT CONTRACT 62304
- PROPOSED STORM SEWER CONSTRUCTED IN CONCURRENT CONTRACT 62304

SHEET 17 OF 65

REVISIONS	
NAME	DATE

ADDENDUM 1 - NSW 05/08/06

ILLINOIS DEPARTMENT OF TRANSPORTATION
F.A.I. 94 (DAN RYAN EXPRESSWAY)
DRAINAGE AND UTILITY PLANS
SB I-94 (DAN RYAN EXPRESSWAY)
SB I-94 STA. 1207+00.00 TO 1213+00.00

SCALE: 1"=20'
 DATE: MARCH 1, 2006
 DRAWN BY: NSB
 CHECKED BY: DA

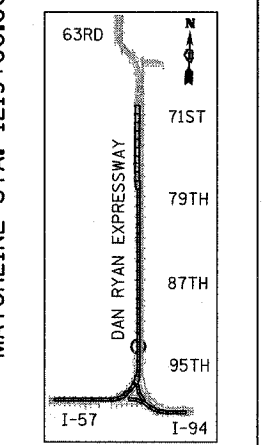
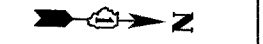
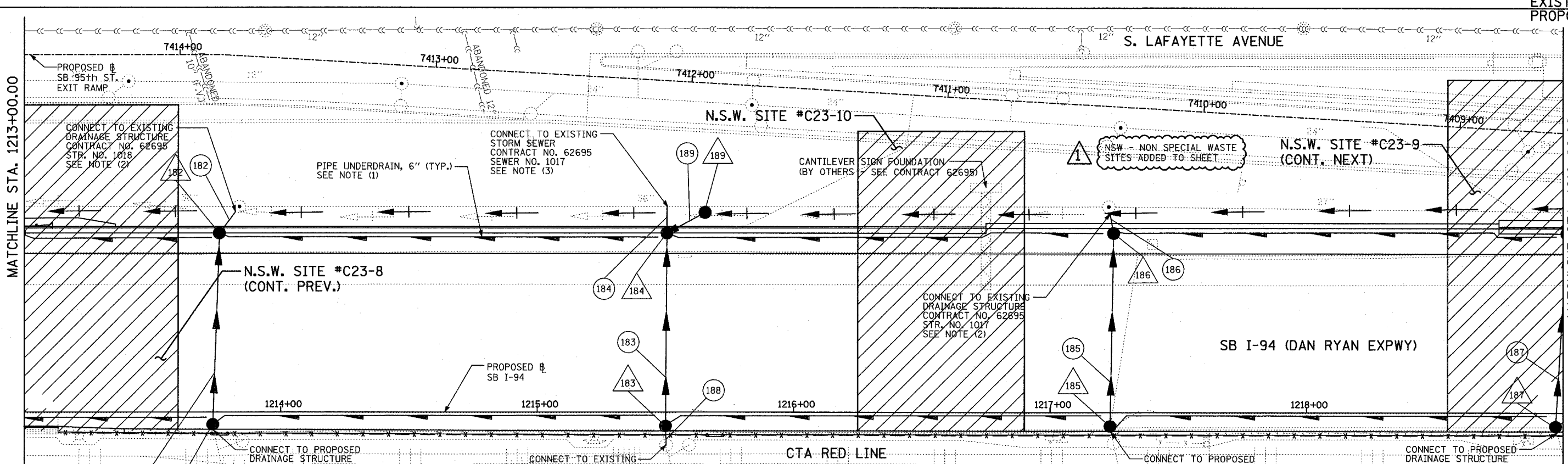
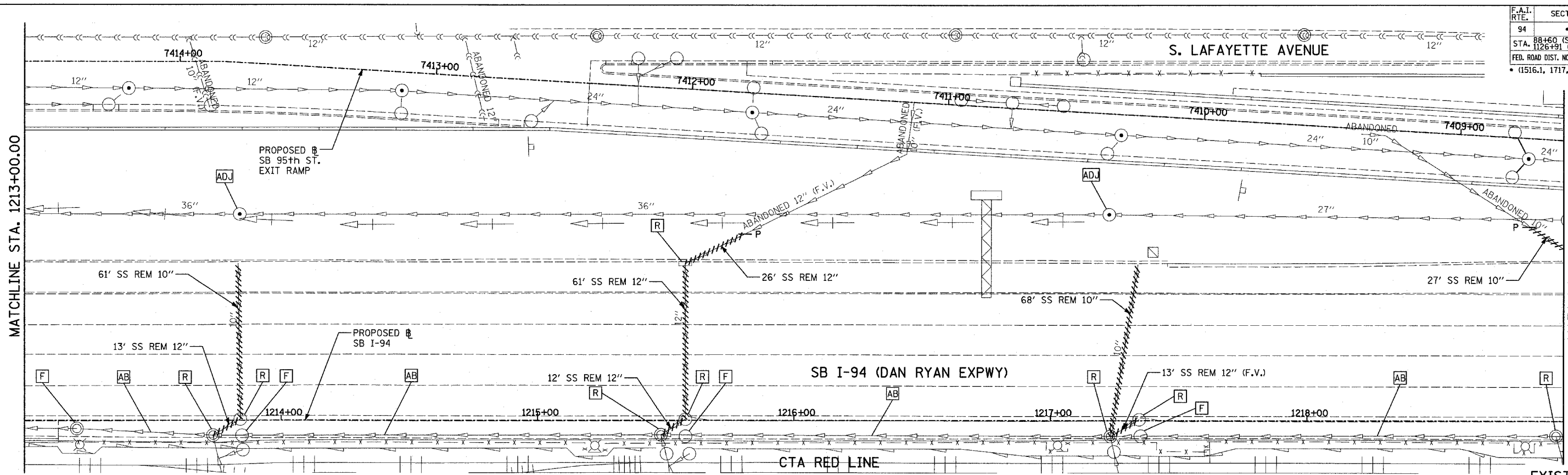

- LEGEND:**
- EXISTING COMBINED SEWER
 - (XY) PROPOSED STORM SEWER NUMBER (X=SHEET NO., Y=PIPE NO.)
 - (XY) PROPOSED STRUCTURE NUMBER (X=SHEET NO., Y=STRUCTURE NO.)
 - PIPE STUBOUT TO BE PLUGGED
 - P SEWER PLUG
 - F.V. FIELD VERIFY
 - ////// UTILITY REMOVAL
 - PROPOSED CATCH BASIN CONSTRUCTED IN CONCURRENT CONTRACT 62304
 - PROPOSED STORM SEWER CONSTRUCTED IN CONCURRENT CONTRACT 62304

- NOTES:**
- FOR CLARITY, PIPE UNDERDRAINS ARE SHOWN OFFSET FROM THEIR PROPOSED LOCATIONS. FOR DETAILED PLACEMENT, SEE SHEET "PIPE UNDERDRAINS DETAIL."
 - CORE DRILL AND CONNECT TO EXISTING DRAINAGE STRUCTURE. CONNECTION COST SHALL BE INCLUDED IN THE COST TO CONSTRUCT THE STORM SEWER.
 - COST SHALL NOT BE PAID FOR SEPARATELY BUT INCLUDED IN COST OF SEWER INSTALLATION.
 - ALL CONNECTIONS TO EXISTING SEWER OR STRUCTURE ALONG CTA SHALL BE FIELD VERIFIED PRIOR TO INSTALLATION AND COORDINATED WITH CTA CONSTRUCTION. COST SHALL BE INCLUDED IN THE COST TO CONSTRUCT THE DRAINAGE STRUCTURE.

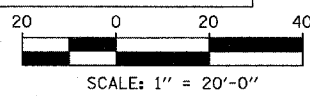

SHEET 18 OF 65

REVISIONS	
NAME	DATE

ILLINOIS DEPARTMENT OF TRANSPORTATION
 F.A.I. 94 (DAN RYAN EXPRESSWAY)
 DRAINAGE AND UTILITY PLAN
 SB I-94 (DAN RYAN EXPRESSWAY)
 SB I-94 STA. 1213+00.00 TO 1219+00.00

SCALE: 1"=20'
 DATE: MARCH 1, 2006

DRAWN BY: NSB
 CHECKED BY: DA

TYLIN INTERNATIONAL

F.A.I. RTE.	SECTION	COUNTY	TOTAL SHEETS	SHEET NO.
94		COOK	764	300
STA. 88+60 (SB I-57) TO STA. 126+91 (SB FORD) TO STA. 1313+00 (SB RYAN)				
FED. ROAD DIST. NO. ILLINOIS FED. AID PROJECT				
• (1516.1, 1717, & 1818) R-5				

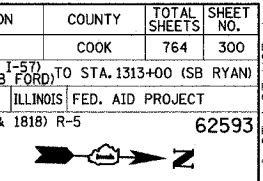
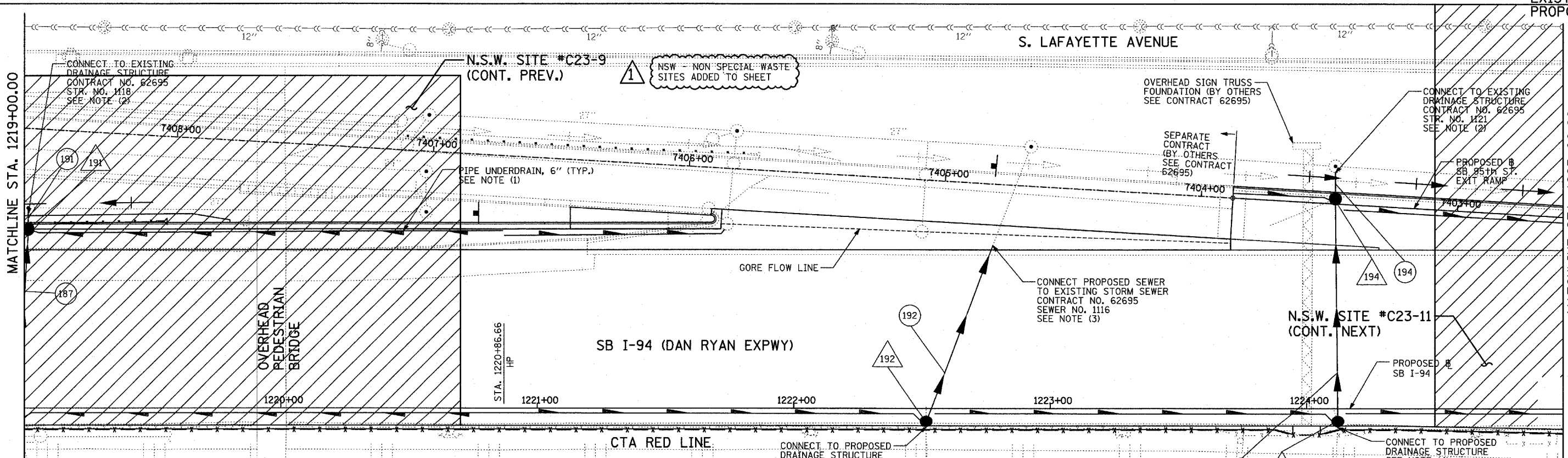
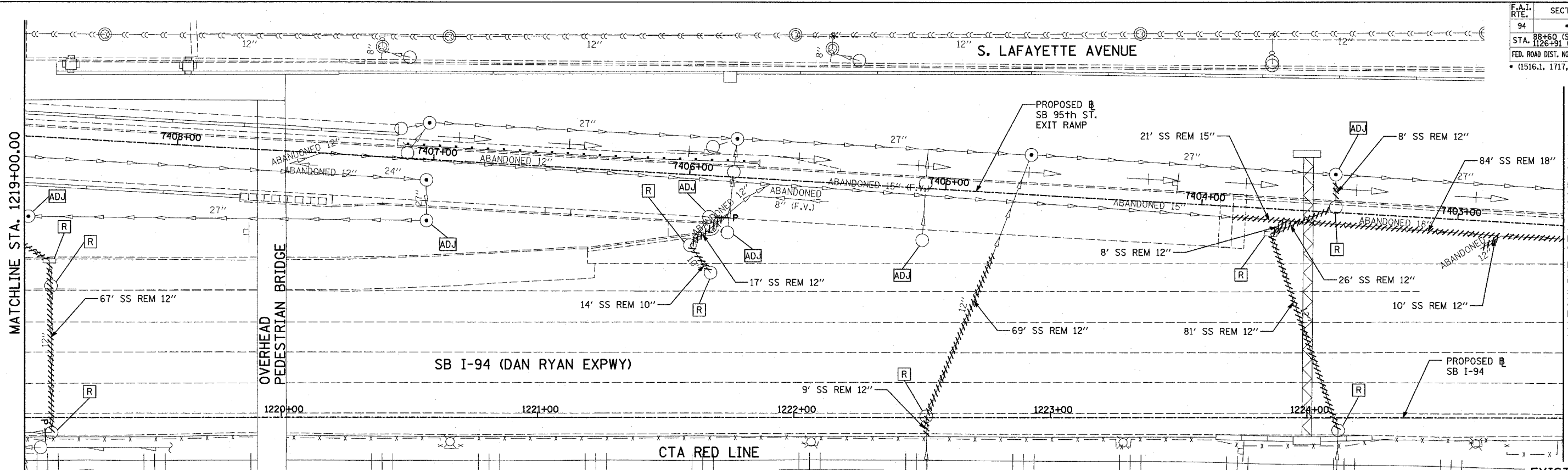

EXISTING CONDITIONS
PROPOSED IMPROVEMENTS

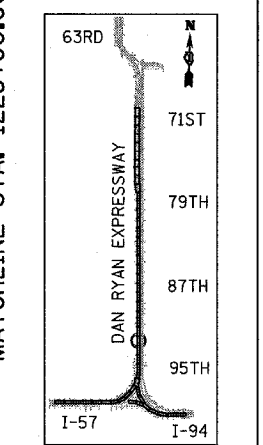
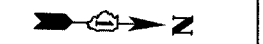

LOCATION MAP

LEGEND:

- EXISTING COMBINED SEWER
- (XY) PROPOSED STORM SEWER NUMBER (X=SHEET NO., Y=PIPE NO.)
- (XY) PROPOSED STRUCTURE NUMBER (X=SHEET NO., Y=STRUCTURE NO.)
- S- PIPE STUBOUT TO BE PLUGGED
- P SEWER PLUG
- F.V. FIELD VERIFY
- ++++ UTILITY REMOVAL
- PROPOSED CATCH BASIN CONSTRUCTED IN CONCURRENT CONTRACT 62304
- PROPOSED STORM SEWER CONSTRUCTED IN CONCURRENT CONTRACT 62304

NOTES:

1. FOR CLARITY, PIPE UNDERDRAINS ARE SHOWN OFFSET FROM THEIR PROPOSED LOCATIONS. FOR DETAILED PLACEMENT, SEE SHEET "PIPE UNDERDRAINS DETAIL."
2. CORE DRILL AND CONNECT TO EXISTING DRAINAGE STRUCTURE. CONNECTION COST SHALL BE INCLUDED IN THE COST TO CONSTRUCT THE STORM SEWER.
3. COST SHALL NOT BE PAID FOR SEPARATELY BUT INCLUDED IN COST OF SEWER INSTALLATION.
4. ALL CONNECTIONS TO EXISTING SEWER OR STRUCTURE ALONG CTA SHALL BE FIELD VERIFIED PRIOR TO INSTALLATION AND COORDINATED WITH CTA CONSTRUCTION. COST SHALL BE INCLUDED IN THE COST TO CONSTRUCT THE DRAINAGE STRUCTURE.

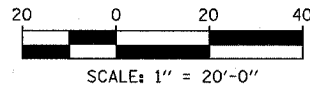

SCALE: 1" = 20'-0"

SHEET 19 OF 65

REVISIONS	
NAME	DATE

ILLINOIS DEPARTMENT OF TRANSPORTATION
F.A.I. 94 (DAN RYAN EXPRESSWAY)
DRAINAGE AND UTILITY PLAN
SB I-94 (DAN RYAN EXPRESSWAY)
SB I-94 STA. 1219+00.00 TO 1225+00.00

SCALE: 1"=20'
DATE: MARCH 1, 2006
DRAWN BY: NSB
CHECKED BY: DA

TYLIN INTERNATIONAL

ADDENDUM 1 - NSW 05/08/06

F.A.I. RTE.	SECTION	COUNTY	TOTAL SHEETS	SHEET NO.
94		COOK	764	301
STA. 98+60 (SB I-57) TO STA. 1313+00 (SB RYAN)				
FED. ROAD DIST. NO. ILLINOIS FED. AID PROJECT				
• (1516.1, 1717, & 1818) R-5				

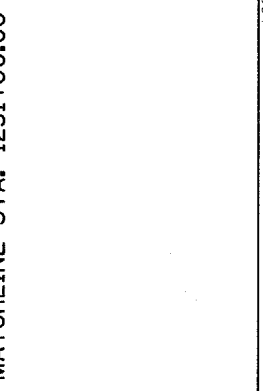
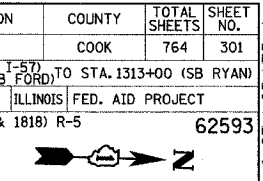
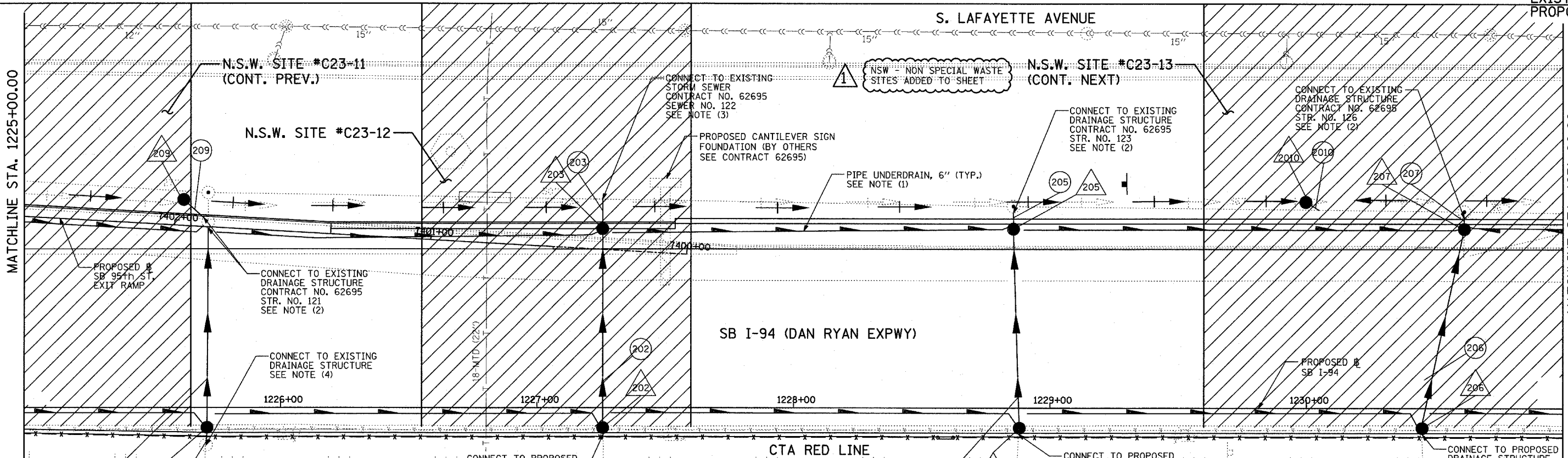
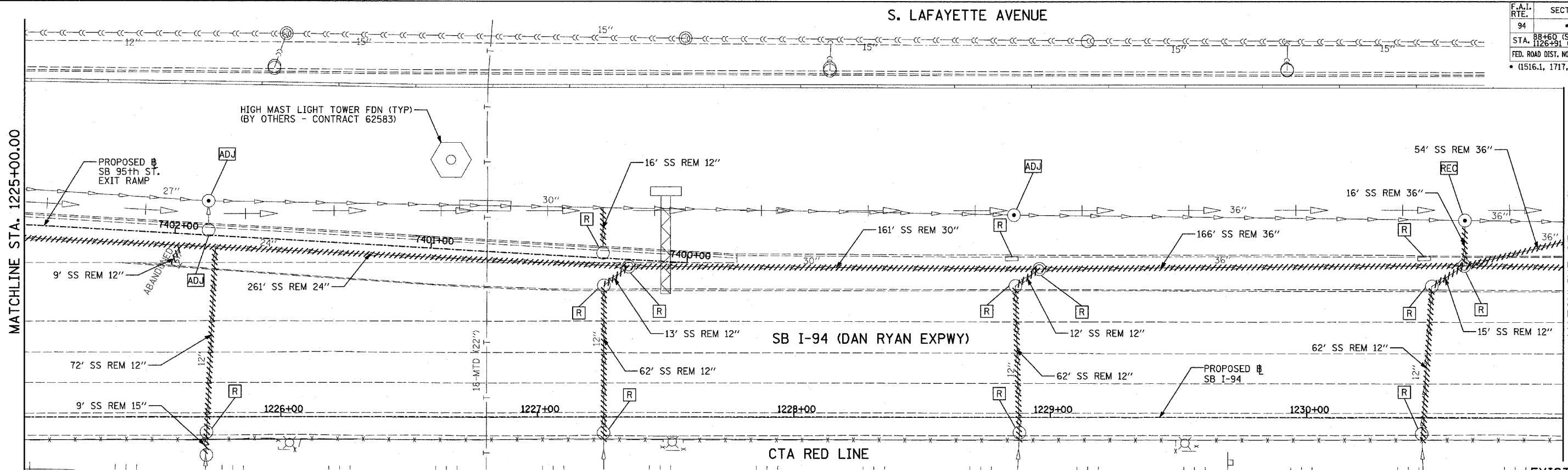

LEGEND:

- EXISTING COMBINED SEWER
- (XY) PROPOSED STORM SEWER NUMBER (X=SHEET NO., Y=PIPE NO.)
- (XY) PROPOSED STRUCTURE NUMBER (X=SHEET NO., Y=STRUCTURE NO.)
- S- PIPE STUBOUT TO BE PLUGGED
- P SEWER PLUG
- F.V. FIELD VERIFY
- UTILITY REMOVAL
- PROPOSED CATCH BASIN CONSTRUCTED IN CONCURRENT CONTRACT 62304
- PROPOSED STORM SEWER CONSTRUCTED IN CONCURRENT CONTRACT 62304

NOTES:

1. FOR CLARITY, PIPE UNDERDRAINS ARE SHOWN OFFSET FROM THEIR PROPOSED LOCATIONS. FOR DETAILED PLACEMENT, SEE SHEET "PIPE UNDERDRAINS DETAIL."
2. CORE DRILL AND CONNECT TO EXISTING DRAINAGE STRUCTURE. CONNECTION COST SHALL BE INCLUDED IN THE COST TO CONSTRUCT THE STORM SEWER.
3. COST SHALL NOT BE PAID FOR SEPARATELY BUT INCLUDED IN COST OF SEWER INSTALLATION.
4. ALL CONNECTIONS TO EXISTING SEWER OR STRUCTURE ALONG CTA SHALL BE FIELD VERIFIED PRIOR TO INSTALLATION AND COORDINATED WITH CTA CONSTRUCTION. COST SHALL BE INCLUDED IN THE COST TO CONSTRUCT THE DRAINAGE STRUCTURE.

SHEET 20 OF 65

REVISIONS	
NAME	DATE

ILLINOIS DEPARTMENT OF TRANSPORTATION
 F.A.I. 94 (DAN RYAN EXPRESSWAY)
 DRAINAGE AND UTILITY PLAN
 SB I-94 (DAN RYAN EXPRESSWAY)
 SB I-94 STA. 1225+00.00 TO 1231+00.00

SCALE: 1"=20'
 DATE: MARCH 1, 2006
 DRAWN BY: NSB
 CHECKED BY: DA

TYLIN INTERNATIONAL

5/15/2006 12:01:57 PM

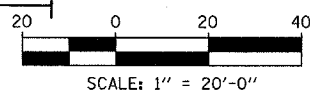
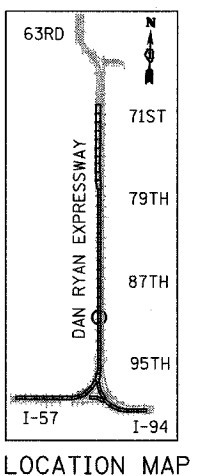
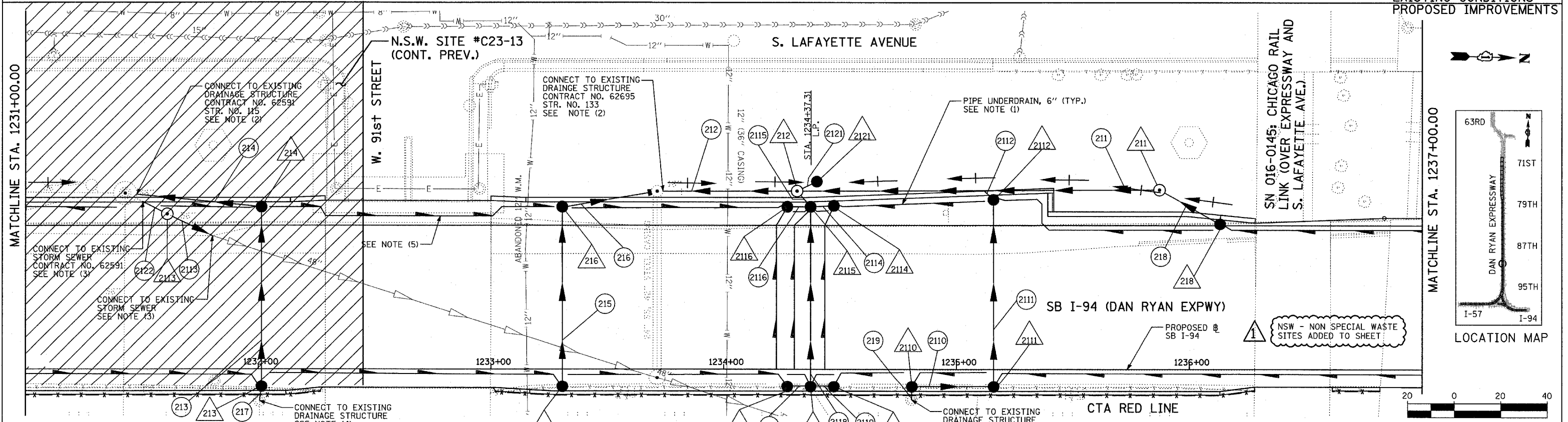
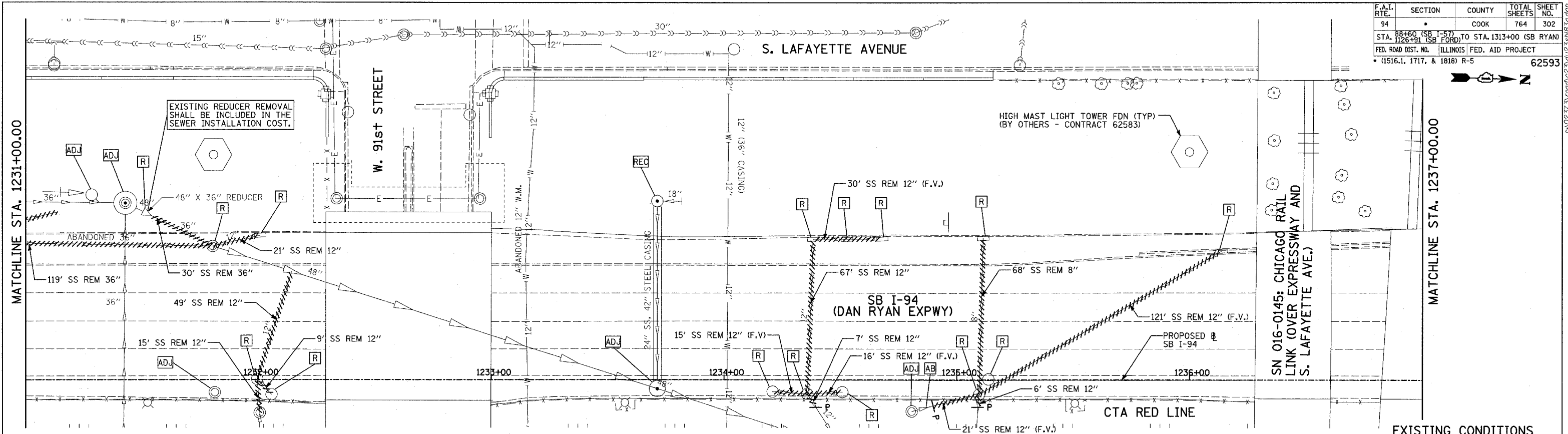

LEGEND:

	EXISTING COMBINED SEWER		SEWER PLUG
	PROPOSED STORM SEWER NUMBER (X=SHEET NO., Y=PIPE NO.)		FIELD VERIFY
	PROPOSED STRUCTURE NUMBER (X=SHEET NO., Y=STRUCTURE NO.)		UTILITY REMOVAL
	PIPE STUBOUT TO BE PLUGGED		PROPOSED CATCH BASIN CONSTRUCTED IN CONCURRENT CONTRACT 62304
			PROPOSED STORM SEWER CONSTRUCTED IN CONCURRENT CONTRACT 62304

- NOTES:**
- FOR CLARITY, PIPE UNDERDRAINS ARE SHOWN OFFSET FROM THEIR PROPOSED LOCATIONS. FOR DETAILED PLACEMENT, SEE SHEET "PIPE UNDERDRAINS DETAIL."
 - CORE DRILL AND CONNECT TO EXISTING DRAINAGE STRUCTURE. CONNECTION COST SHALL BE INCLUDED IN THE COST TO CONSTRUCT THE STORM SEWER.
 - COST SHALL NOT BE PAID FOR SEPARATELY BUT INCLUDED IN COST OF SEWER INSTALLATION.
 - ALL CONNECTIONS TO EXISTING SEWER OR STRUCTURE ALONG CTA SHALL BE FIELD VERIFIED PRIOR TO INSTALLATION AND COORDINATED WITH CTA CONSTRUCTION. COST SHALL BE INCLUDED IN THE COST TO CONSTRUCT THE DRAINAGE STRUCTURE.
 - PROPOSED PIPE UNDERDRAIN SYSTEM LOCATION SHALL BE COORDINATED WITH PROPOSED ELECTRICAL DUCT BANK AND EXISTING FOOTING. SEE TYPICAL SECTIONS AND DETAILS FOR OVERPASS FOOTINGS.

SHEET 21 OF 65

REVISIONS	
NAME	DATE

ADDENDUM 1 - NSW 05/08/06

ILLINOIS DEPARTMENT OF TRANSPORTATION
F.A.I. 94 (DAN RYAN EXPRESSWAY)
DRAINAGE AND UTILITY PLAN
SB I-94 (DAN RYAN EXPRESSWAY)
SB I-94 STA. 1231+00.00 TO 1237+00.00

SCALE: 1"=20'
 DATE: MARCH 1, 2006
 DRAWN BY: NSB
 CHECKED BY: DA

S. LAFAYETTE AVENUE

F.A.I. RTE.	SECTION	COUNTY	TOTAL SHEETS	SHEET NO.
94		COOK	764	304
STA. 88+60 (SB I-57) TO STA. 1313+00 (SB RYAN)				
FED. ROAD DIST. NO. ILLINOIS FED. AID PROJECT				
• (1516.1, 1717, & 1818) R-5 62593				

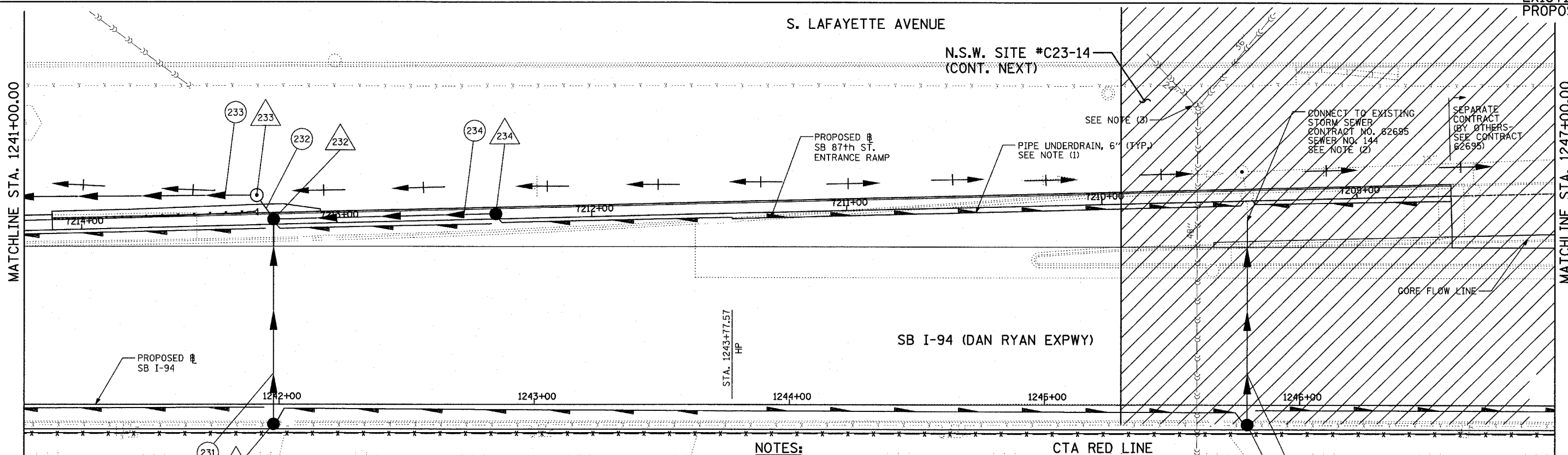
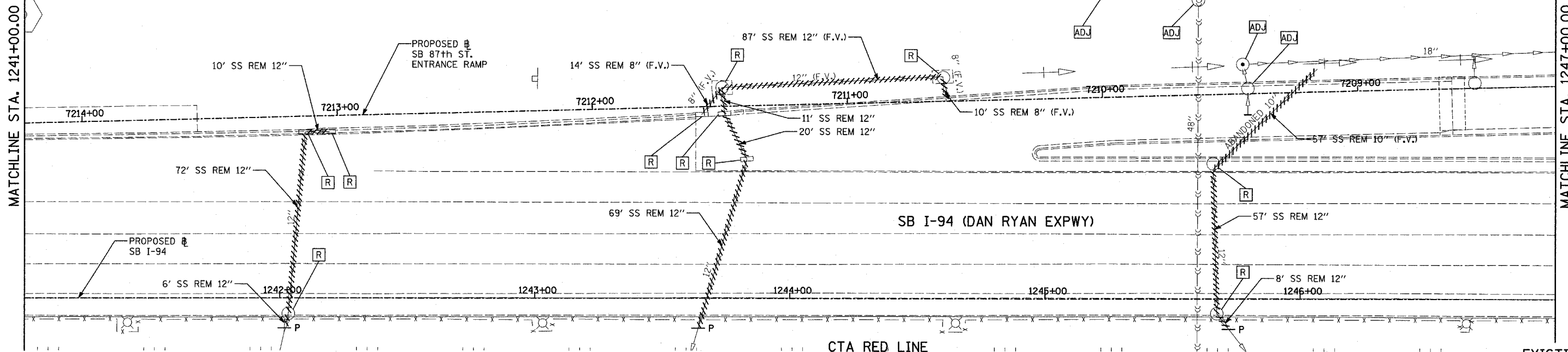

EXISTING CONDITIONS
PROPOSED IMPROVEMENTS

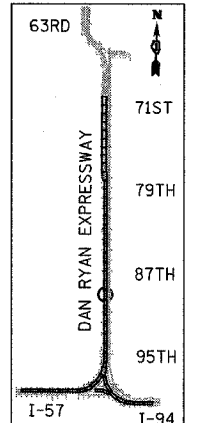

LEGEND:

- EXISTING COMBINED SEWER
- PROPOSED STORM SEWER NUMBER (X=SHEET NO., Y=PIPE NO.)
- PROPOSED STRUCTURE NUMBER (X=SHEET NO., Y=STRUCTURE NO.)
- PIPE STUBOUT TO BE PLUGGED
- P SEWER PLUG
- F.V. FIELD VERIFY
- UTILITY REMOVAL
- PROPOSED CATCH BASIN CONSTRUCTED IN CONCURRENT CONTRACT 62304
- PROPOSED STORM SEWER CONSTRUCTED IN CONCURRENT CONTRACT 62304

NOTES:

1. FOR CLARITY, PIPE UNDERDRAINS ARE SHOWN OFFSET FROM THEIR PROPOSED LOCATIONS. FOR DETAILED PLACEMENT, SEE SHEET "PIPE UNDERDRAINS DETAIL."
2. COST SHALL NOT BE PAID FOR SEPARATELY BUT INCLUDED IN COST OF SEWER INSTALLATION.
3. THE CONTRACTOR SHALL COORDINATE ALL WORK WITH COC-DOWN SEWER SECTION PRIOR TO ANY EXCAVATION. RISER SHAFTS, IF ENCOUNTERED, SHALL BE CONSTRUCTED AND PAID FOR AS PER DETAIL SHOWN ON DRAINAGE DETAIL SHEET 3 OF 3.

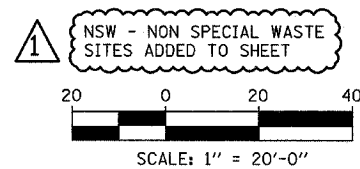

SHEET 23 OF 65

REVISIONS	
NAME	DATE

ILLINOIS DEPARTMENT OF TRANSPORTATION
F.A.I. 94 (DAN RYAN EXPRESSWAY)
DRAINAGE AND UTILITY PLAN
SB I-94 (DAN RYAN EXPRESSWAY)
SB I-94 STA. 1241+00.00 TO 1247+00.00

SCALE: 1"=20'
DATE: MARCH 1, 2006

DRAWN BY: NSB
CHECKED BY: DA

TYLIN INTERNATIONAL

5/15/2006 12:02:06 PM

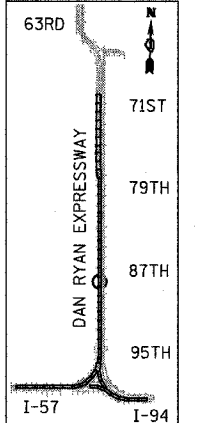
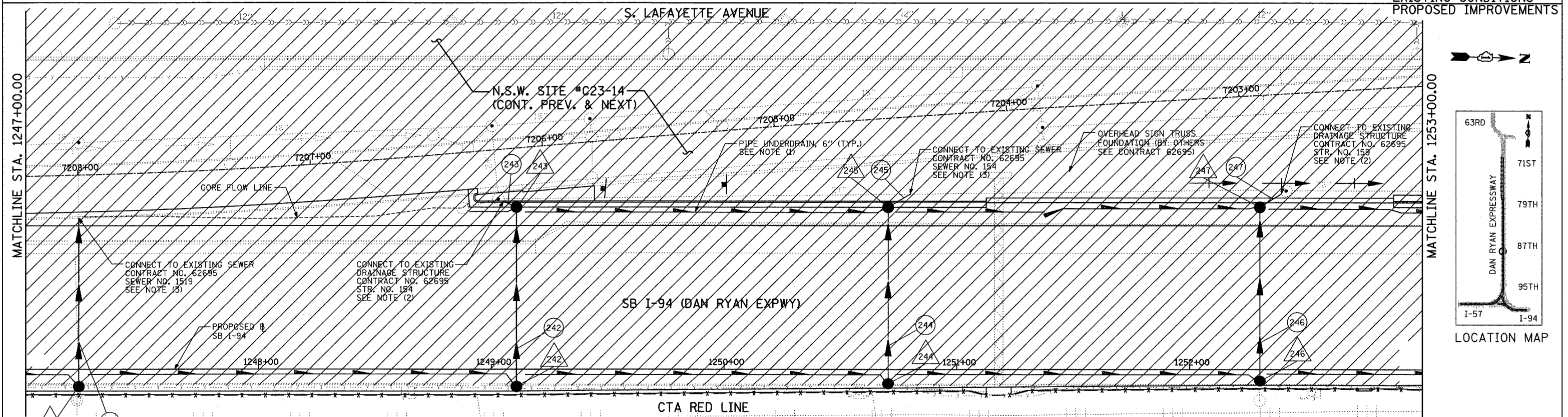
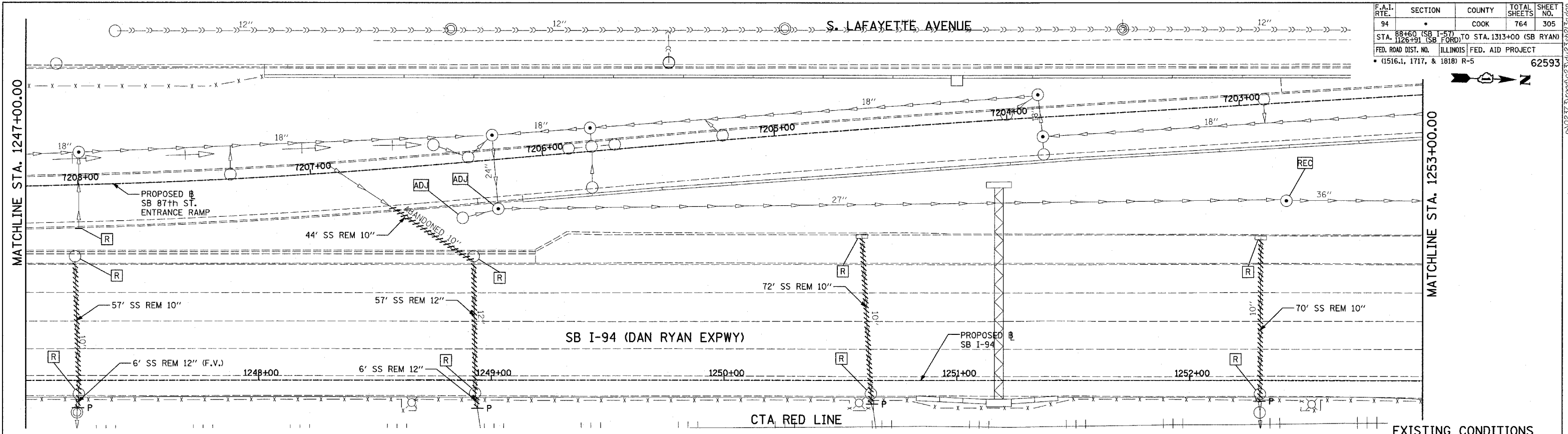

LEGEND:

- EXISTING COMBINED SEWER
- PROPOSED STORM SEWER NUMBER (X=SHEET NO., Y=PIPE NO.)
- PROPOSED STRUCTURE NUMBER (X=SHEET NO., Y=STRUCTURE NO.)
- PIPE STUBOUT TO BE PLUGGED
- SEWER PLUG
- F.V. FIELD VERIFY
- UTILITY REMOVAL
- PROPOSED CATCH BASIN CONSTRUCTED IN CONCURRENT CONTRACT 62304
- PROPOSED STORM SEWER CONSTRUCTED IN CONCURRENT CONTRACT 62304

NOTES:

1. FOR CLARITY, PIPE UNDERDRAINS ARE SHOWN OFFSET FROM THEIR PROPOSED LOCATIONS. FOR DETAILED PLACEMENT, SEE SHEET "PIPE UNDERDRAINS DETAIL."
2. CORE DRILL AND CONNECT TO EXISTING DRAINAGE STRUCTURE. CONNECTION COST SHALL BE INCLUDED IN THE COST TO CONSTRUCT THE STORM SEWER.
3. COST SHALL NOT BE PAID FOR SEPARATELY BUT INCLUDED IN COST OF SEWER INSTALLATION.

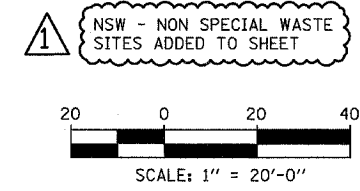

SHEET 24 OF 65

REVISIONS	
NAME	DATE

ADDENDUM 1 - NSW 05/08/06

ILLINOIS DEPARTMENT OF TRANSPORTATION
F.A.I. 94 (DAN RYAN EXPRESSWAY)
DRAINAGE AND UTILITY PLAN
SB I-94 (DAN RYAN EXPRESSWAY)
SB I-94 STA. 1247+00.00 TO 1253+00.00

SCALE: 1"=20'
 DATE: MARCH 1, 2006
 DRAWN BY: NSB
 CHECKED BY: DA

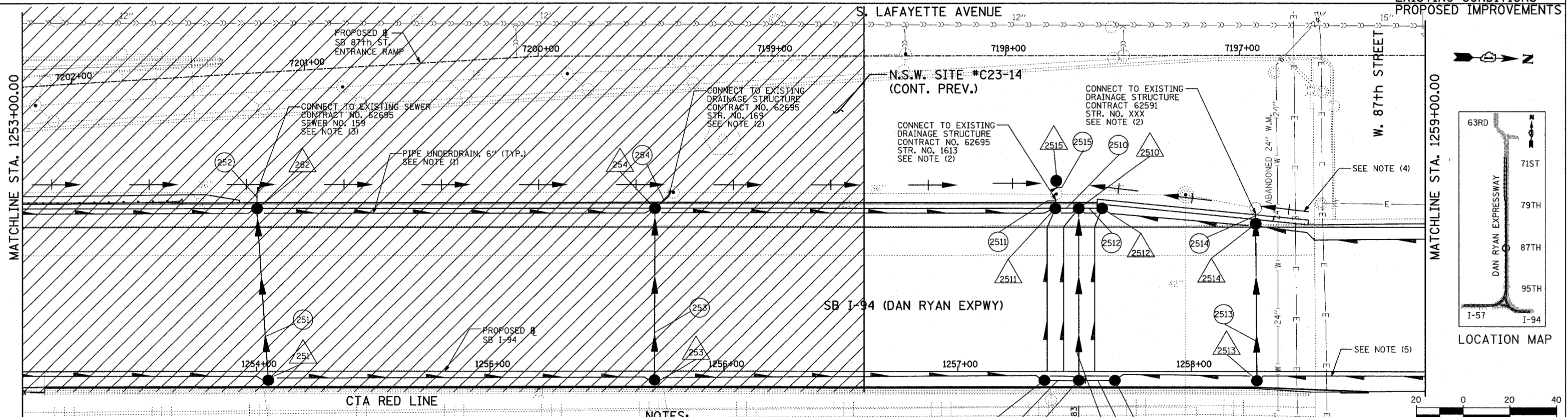
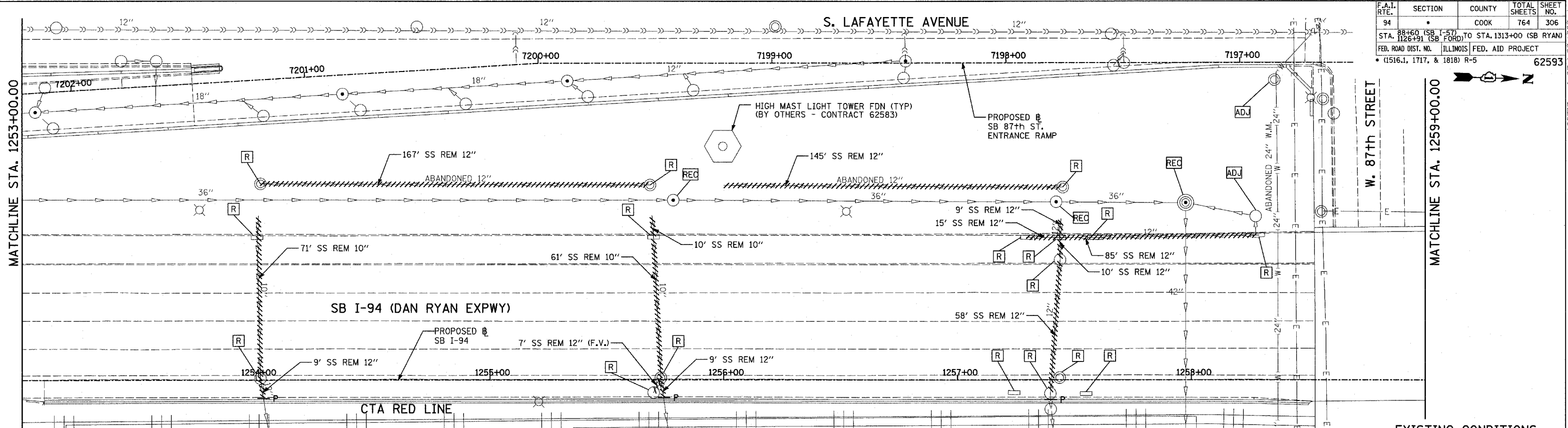

LEGEND:

	EXISTING COMBINED SEWER		SEWER PLUG
	PROPOSED STORM SEWER NUMBER (X=SHEET NO., Y=PIPE NO.)		F.V. FIELD VERIFY
	PROPOSED STRUCTURE NUMBER (X=SHEET NO., Y=STRUCTURE NO.)		UTILITY REMOVAL
	PIPE STUBOUT TO BE PLUGGED		PROPOSED CATCH BASIN CONSTRUCTED IN CONCURRENT CONTRACT 62304
			PROPOSED STORM SEWER CONSTRUCTED IN CONCURRENT CONTRACT 62304

- NOTES:**
- FOR CLARITY, PIPE UNDERDRAINS ARE SHOWN OFFSET FROM THEIR PROPOSED LOCATIONS. FOR DETAILED PLACEMENT, SEE SHEET "PIPE UNDERDRAINS DETAIL."
 - CORE DRILL AND CONNECT TO EXISTING DRAINAGE STRUCTURE. CONNECTION COST SHALL BE INCLUDED IN THE COST TO CONSTRUCT THE STORM SEWER.
 - COST SHALL NOT BE PAID FOR SEPARATELY BUT INCLUDED IN COST OF SEWER INSTALLATION.
 - CONSTRUCT SWALE TO DRAIN TO EXISTING STRUCTURE.

1 NSW - NON SPECIAL WASTE SITES ADDED TO SHEET

SHEET 25 OF 65

SCALE: 1" = 20'-0"

REVISIONS	
NAME	DATE

ILLINOIS DEPARTMENT OF TRANSPORTATION
 F.A.I. 94 (DAN RYAN EXPRESSWAY)
 DRAINAGE AND UTILITY PLAN
 SB I-94 (DAN RYAN EXPRESSWAY)
 SB I-94 STA. 1253+00.00 TO 1259+00.00

SCALE: 1"=20'
 DATE: MARCH 1, 2006

DRAWN BY: NSB
 CHECKED BY: DA

TYLIN INTERNATIONAL

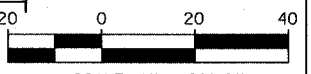
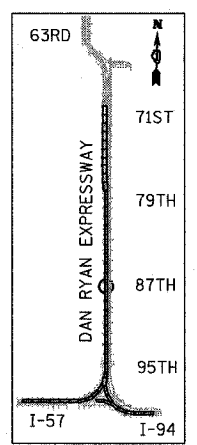

F.A.I. RTE. 94	SECTION	COUNTY COOK	TOTAL SHEETS 764	SHEET NO. 307
STA. 88+60 (SB I-57) TO STA. 1313+00 (SB RYAN)				
FED. ROAD DIST. NO. ILLINOIS FED. AID PROJECT				
• (1516.1, 1717, & 1818) R-5				
				62593

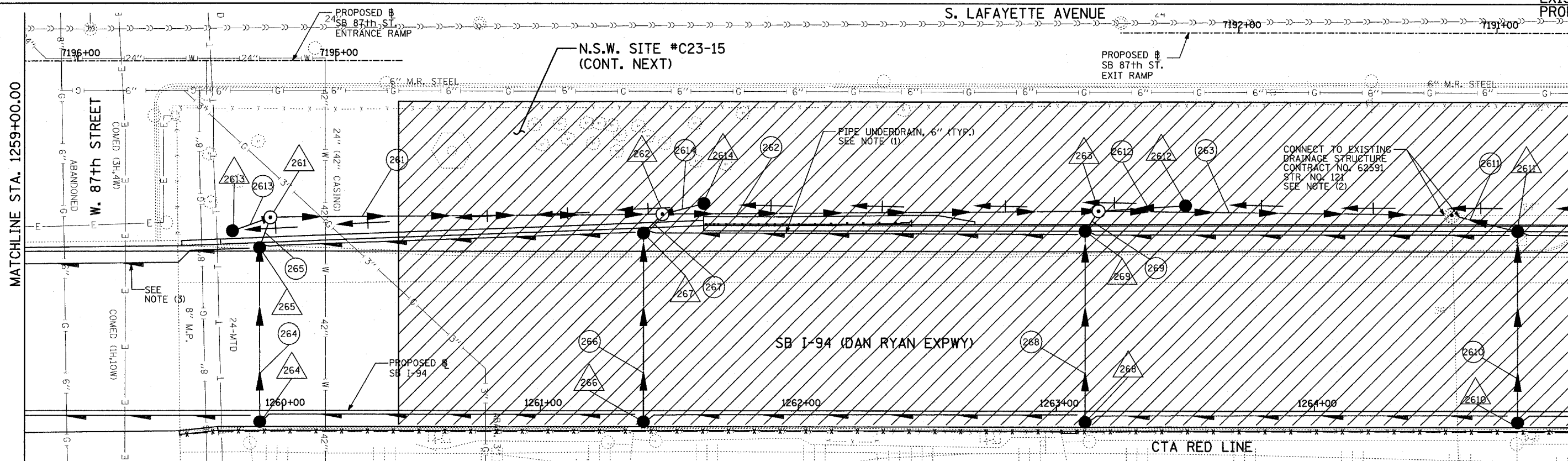
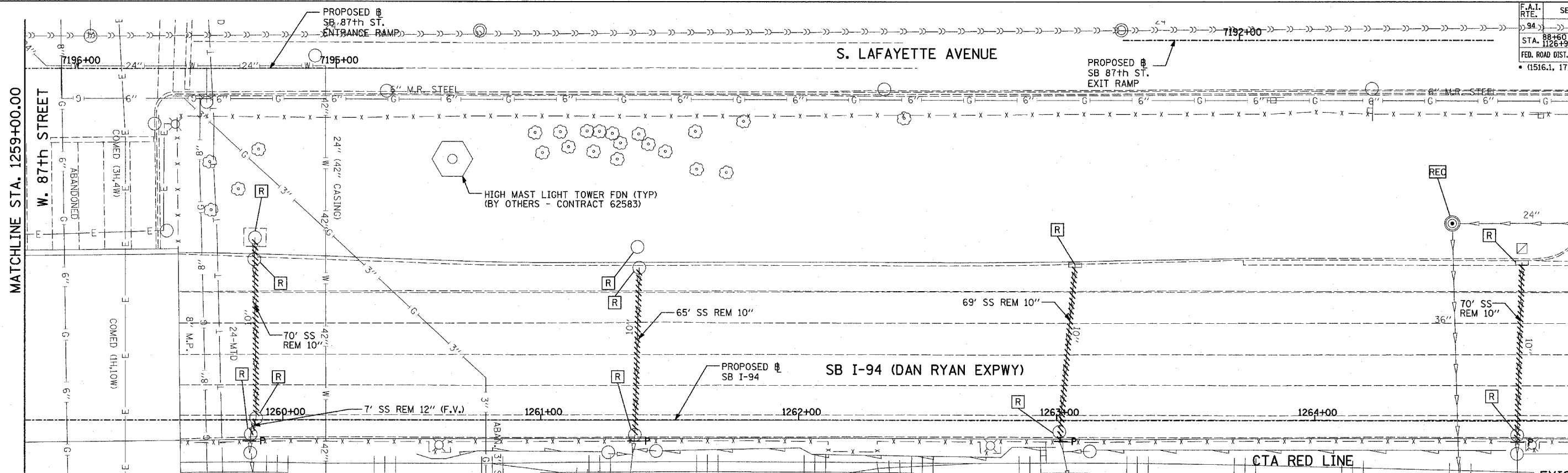

EXISTING CONDITIONS
PROPOSED IMPROVEMENTS

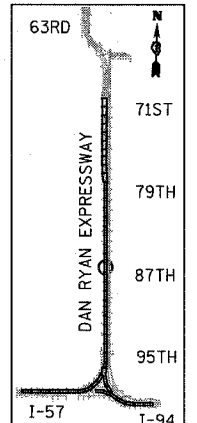

LOCATION MAP

LEGEND:

- EXISTING COMBINED SEWER
- (XY) PROPOSED STORM SEWER NUMBER (X=SHEET NO., Y=PIPE NO.)
- (XY) PROPOSED STRUCTURE NUMBER (X=SHEET NO., Y=STRUCTURE NO.)
- S- PIPE STUBOUT TO BE PLUGGED
- P SEWER PLUG
- F.V. FIELD VERIFY
- UTILITY REMOVAL
- PROPOSED CATCH BASIN CONSTRUCTED IN CONCURRENT CONTRACT 62304
- PROPOSED STORM SEWER CONSTRUCTED IN CONCURRENT CONTRACT 62304

NOTES:

- FOR CLARITY, PIPE UNDERDRAINS ARE SHOWN OFFSET FROM THEIR PROPOSED LOCATIONS. FOR DETAILED PLACEMENT, SEE SHEET "PIPE UNDERDRAINS DETAIL."
- CORE DRILL AND CONNECT TO EXISTING DRAINAGE STRUCTURE. CONNECTION COST SHALL BE INCLUDED IN THE COST TO CONSTRUCT THE STORM SEWER.
- PROPOSED PIPE UNDERDRAIN SYSTEM LOCATION SHALL BE COORDINATED WITH PROPOSED ELECTRICAL DUCT BANK AND EXISTING FOOTING. SEE TYPICAL SECTIONS AND DETAILS FOR OVERPASS FOOTINGS.

1 NSW - NON SPECIAL WASTE SITES ADDED TO SHEET

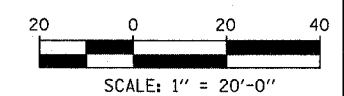

SHEET 26 OF 65

REVISIONS	
NAME	DATE

ILLINOIS DEPARTMENT OF TRANSPORTATION
F.A.I. 94 (DAN RYAN EXPRESSWAY)
DRAINAGE AND UTILITY PLAN
SB I-94 (DAN RYAN EXPRESSWAY)
SB I-94 STA. 1259+00.00 TO 1265+00.00

SCALE: 1"=20'
DATE: MARCH 1, 2006

DRAWN BY: NSB
CHECKED BY: DA

TYLIN INTERNATIONAL

ADDENDUM 1 - NSW 05/08/06

5/5/2006 12:02:20 PM

F.A.I. RTE.	SECTION	COUNTY	TOTAL SHEETS	SHEET NO.
94		COOK	764	308
STA. 88+60 (SB I-57) TO STA. 1313+00 (SB RYAN)				
FED. ROAD DIST. NO. ILLINOIS FED. AID PROJECT				
• (1516J, 1717, & 1818) R-5				
				62593

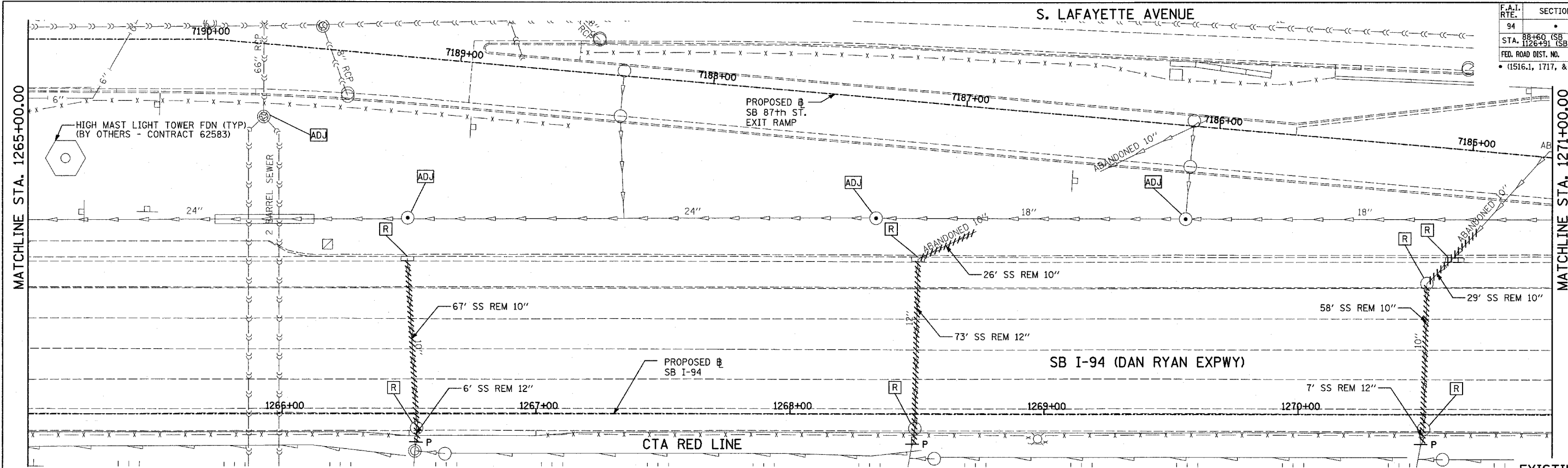

EXISTING CONDITIONS
PROPOSED IMPROVEMENTS

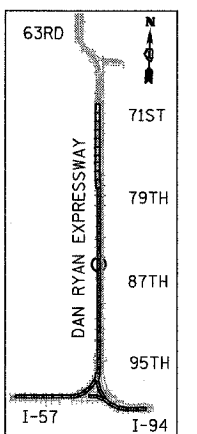
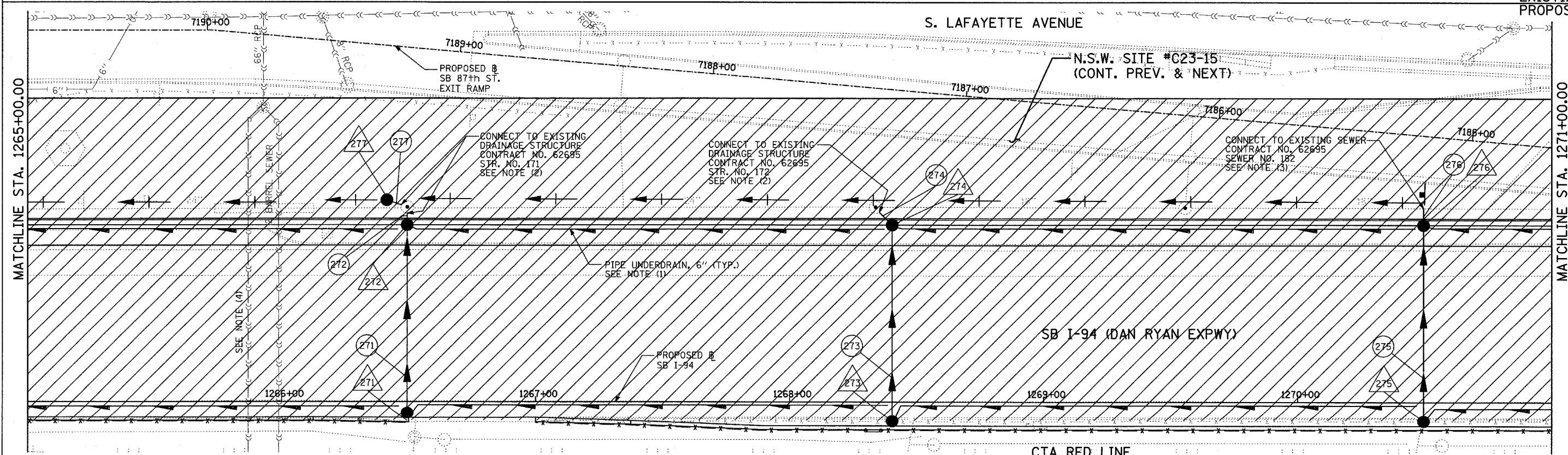

LOCATION MAP

LEGEND:

- — — — — EXISTING COMBINED SEWER
- (XY) PROPOSED STORM SEWER NUMBER (X=SHEET NO., Y=PIPE NO.)
- (XY) PROPOSED STRUCTURE NUMBER (X=SHEET NO., Y=STRUCTURE NO.)
- S — — — — — PIPE STUBOUT TO BE PLUGGED
- P SEWER PLUG
- F.V. FIELD VERIFY
- +++++ UTILITY REMOVAL
- PROPOSED CATCH BASIN CONSTRUCTED IN CONCURRENT CONTRACT 62304
- PROPOSED STORM SEWER CONSTRUCTED IN CONCURRENT CONTRACT 62304

NOTES:

1. FOR CLARITY, PIPE UNDERDRAINS ARE SHOWN OFFSET FROM THEIR PROPOSED LOCATIONS. FOR DETAILED PLACEMENT, SEE SHEET "PIPE UNDERDRAINS DETAIL."
2. CORE DRILL AND CONNECT TO EXISTING DRAINAGE STRUCTURE. CONNECTION COST SHALL BE INCLUDED IN THE COST TO CONSTRUCT THE STORM SEWER.
3. COST SHALL NOT BE PAID FOR SEPARATELY BUT INCLUDED IN COST OF SEWER INSTALLATION.
4. THE CONTRACTOR SHALL COORDINATE ALL WORK WITH COC-DOWN SEWER SECTION PRIOR TO ANY EXCAVATION. RISER SHAFTS, IF ENCOUNTERED, SHALL BE CONSTRUCTED AND PAID FOR AS PER DETAIL SHOWN ON DRAINAGE DETAIL SHEET 3 OF 3.

NSW - NON SPECIAL WASTE SITES ADDED TO SHEET

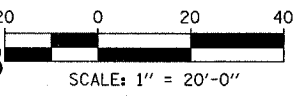

SHEET 27 OF 65

REVISIONS	
NAME	DATE

ILLINOIS DEPARTMENT OF TRANSPORTATION
F.A.I. 94 (DAN RYAN EXPRESSWAY)
DRAINAGE AND UTILITY PLAN
SB I-94 (DAN RYAN EXPRESSWAY)
SB I-94 STA. 1265+00.00 TO 1271+00.00

SCALE: 1"=20'
DATE: MARCH 1, 2006

DRAWN BY: NSB
CHECKED BY: DA

TYLIN INTERNATIONAL

ADDENDUM 1 - NSW 05/08/06

F.A.I. RTE.	SECTION	COUNTY	TOTAL SHEETS	SHEET NO.
94		COOK	764	309
STA. 68+60 (SB I-57) TO STA. 1313+00 (SB RYAN)				
FED. ROAD DIST. NO. ILLINOIS FED. AID PROJECT				
• (1516.1, 1717, & 1818) R-5				
				62593

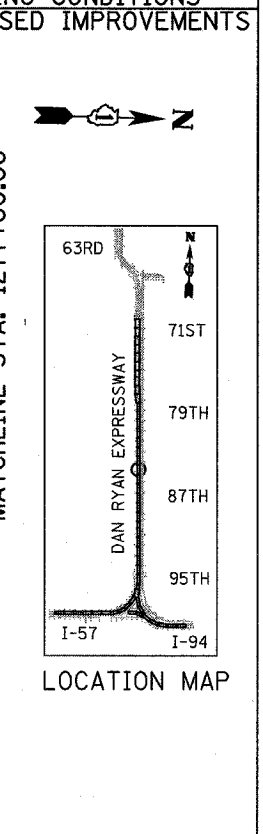
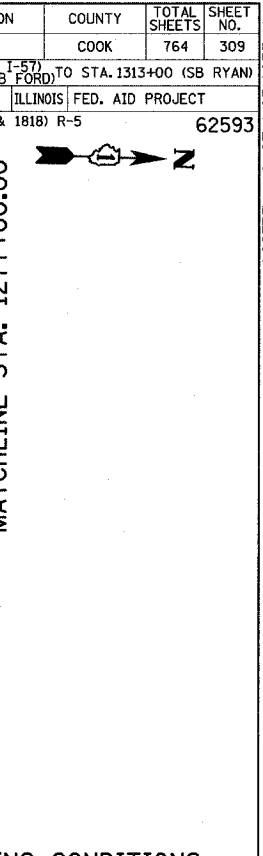
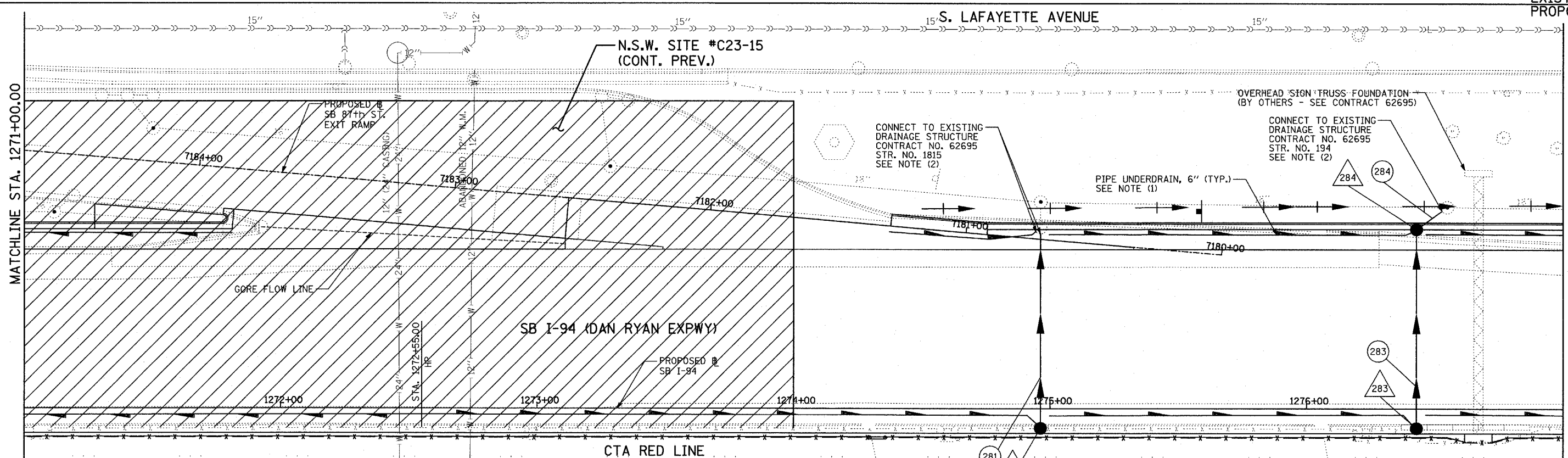
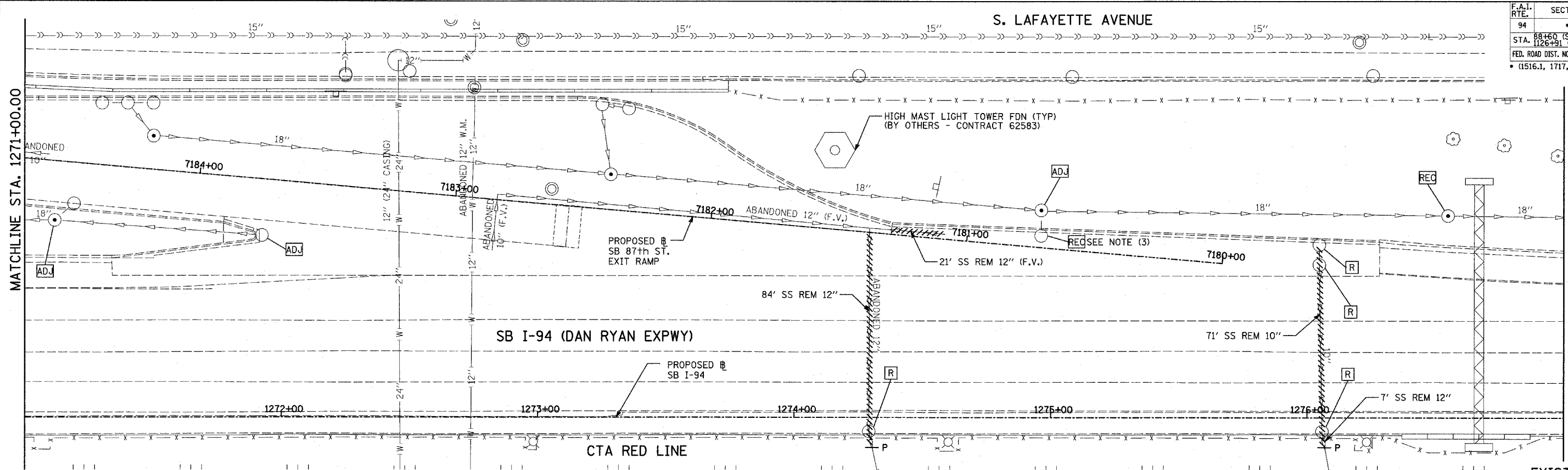

LEGEND:

- EXISTING COMBINED SEWER
- PROPOSED STORM SEWER NUMBER (X=SHEET NO., Y=PIPE NO.)
- PROPOSED STRUCTURE NUMBER (X=SHEET NO., Y=STRUCTURE NO.)
- PIPE STUBOUT TO BE PLUGGED
- SEWER PLUG
- F.V. FIELD VERIFY
- UTILITY REMOVAL
- PROPOSED CATCH BASIN CONSTRUCTED IN CONCURRENT CONTRACT 62304
- PROPOSED STORM SEWER CONSTRUCTED IN CONCURRENT CONTRACT 62304

NOTES:

1. FOR CLARITY, PIPE UNDERDRAINS ARE SHOWN OFFSET FROM THEIR PROPOSED LOCATIONS. FOR DETAILED PLACEMENT, SEE SHEET "PIPE UNDERDRAINS DETAIL."
2. CORE DRILL AND CONNECT TO EXISTING DRAINAGE STRUCTURE. CONNECTION COST SHALL BE INCLUDED IN THE COST TO CONSTRUCT THE STORM SEWER.
3. REMOVE AND REPLACE CONE. ROTATE CONE AND INSTALL LID IN THE GUTTER.

NSW - NON SPECIAL WASTE SITES ADDED TO SHEET

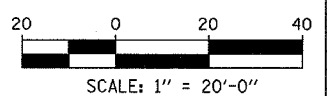

SHEET 28 OF 65

REVISIONS	
NAME	DATE

ILLINOIS DEPARTMENT OF TRANSPORTATION
 F.A.I. 94 (DAN RYAN EXPRESSWAY)
 DRAINAGE AND UTILITY PLAN
 SB I-94 (DAN RYAN EXPRESSWAY)
 SB I-94 STA. 1271+00.00 TO 1277+00.00

SCALE: 1"=20'
 DATE: MARCH 1, 2006
 DRAWN BY: NSB
 CHECKED BY: DA

TYLIN INTERNATIONAL

F.A.I. RTE.	SECTION	COUNTY	TOTAL SHEETS	SHEET NO.
94		COOK	764	327
STA. 88+50 (SB I-57) TO STA. 131+00 (SB RYAN)				
FED. ROAD DIST. NO. ILLINOIS FED. AID PROJECT				
• (1516.1, 1717, & 1818) R-5				
				62593

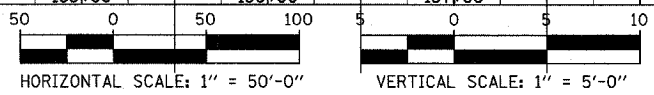
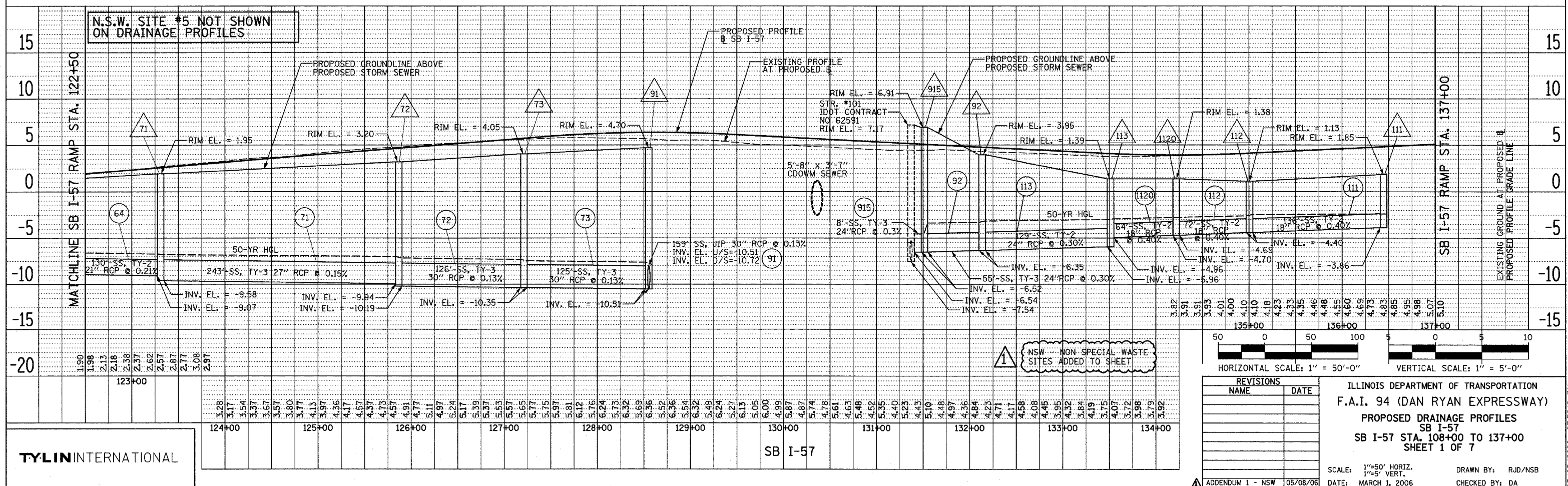
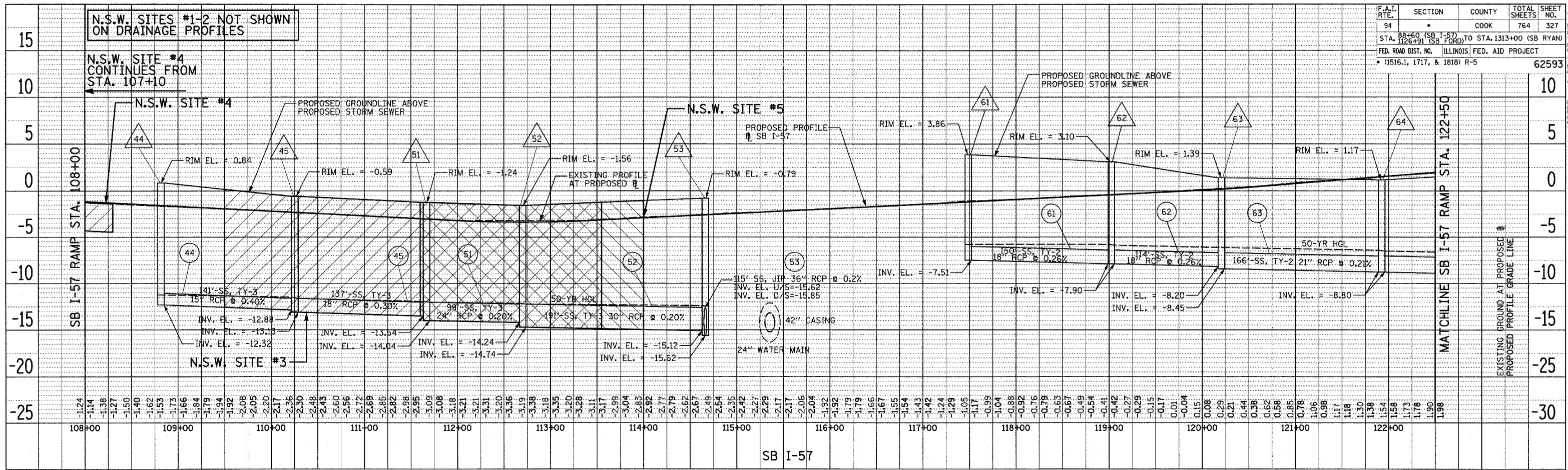

REVISIONS	
NAME	DATE

ILLINOIS DEPARTMENT OF TRANSPORTATION
 F.A.I. 94 (DAN RYAN EXPRESSWAY)
 PROPOSED DRAINAGE PROFILES
 SB I-57
 SB I-57 STA. 108+00 TO 137+00
 SHEET 1 OF 7

SCALE: 1"=50' HORIZ.
 1"=5' VERT.
 DATE: MARCH 1, 2006

DRAWN BY: RJD/NSB
 CHECKED BY: DA

TYLIN INTERNATIONAL

DATE: _____
 BY: _____
 PLAN NO.: _____
 CHECKED: _____
 DATE: _____

05/05/2006 03:56:02 PM

F.A.I. RTE.	SECTION	COUNTY	TOTAL SHEETS	SHEET NO.
94		COOK	764	328
STA. 88+60 (SB I-57) TO STA. 1313+00 (SB RYAN)				
FED. ROAD DIST. NO. ILLINOIS FED. AID PROJECT				
• (1516, 1, 1717, & 1818) R-5 62593				

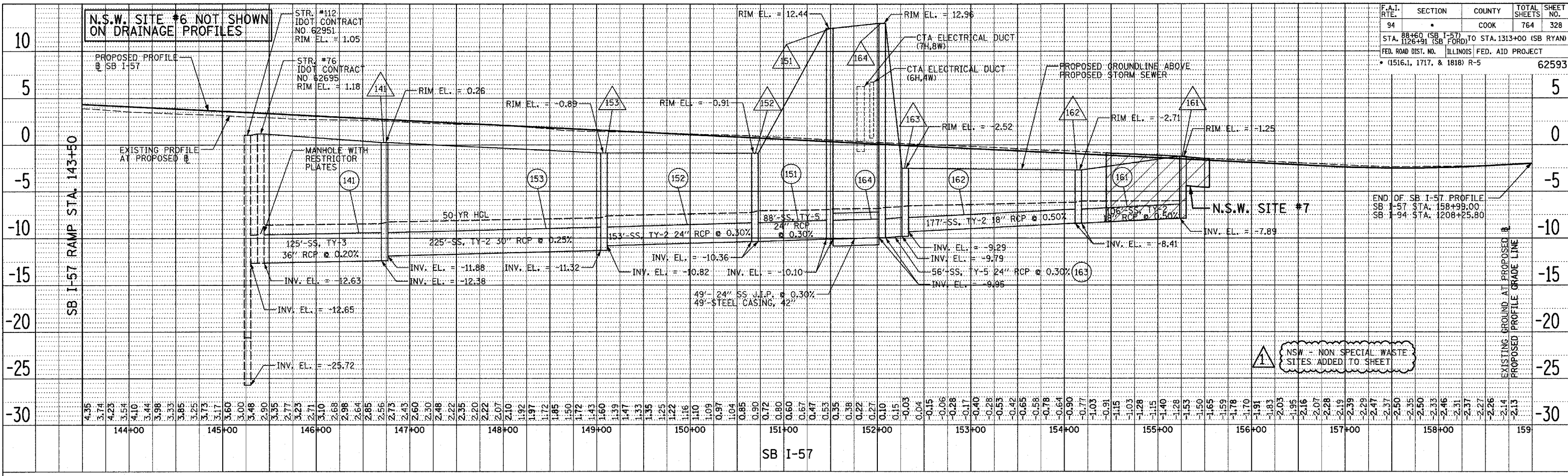

NSW - NON SPECIAL WASTE SITES ADDED TO SHEET

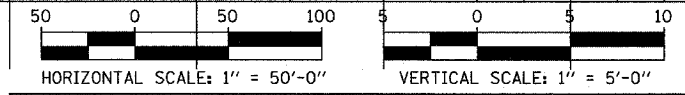
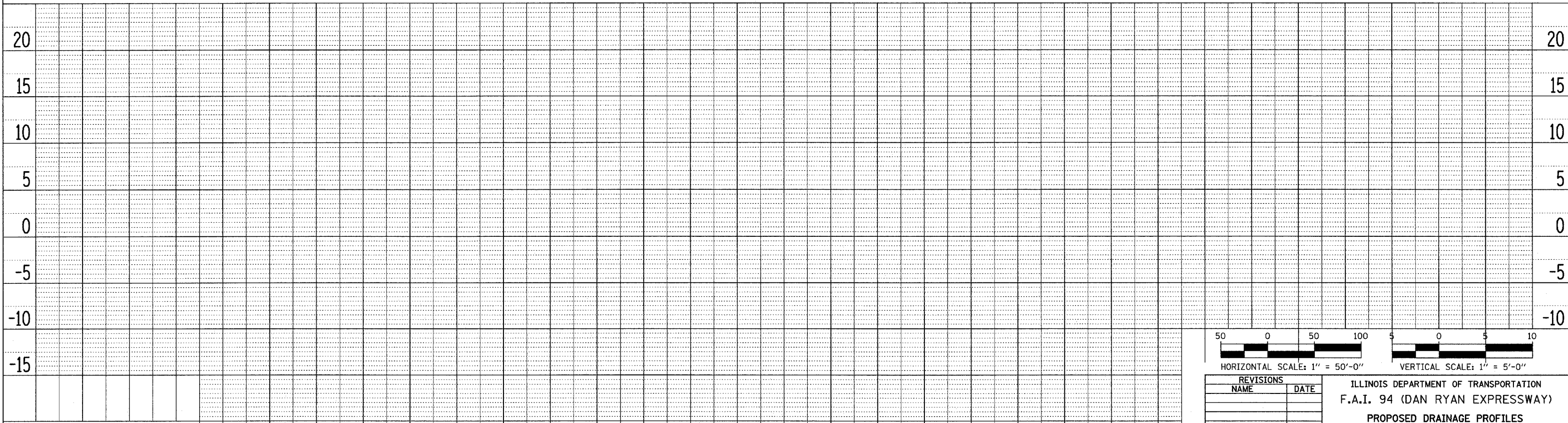

REVISIONS	
NAME	DATE

ILLINOIS DEPARTMENT OF TRANSPORTATION
 F.A.I. 94 (DAN RYAN EXPRESSWAY)
 PROPOSED DRAINAGE PROFILES
 SB I-57
 SB I-57 STA. 143+50 TO 158+99
 SHEET 2 OF 7

SCALE: 1"=50' HORIZ.
 1"=5' VERT.
 DATE: MARCH 1, 2006
 DRAWN BY: RJD/NSB
 CHECKED BY: DA

ADDENDUM 1 - NSW 05/08/06

TYLIN INTERNATIONAL

PLAN SURVEYED PLOTTED CHECKED BY: DATE
 NOTE BOOK NO. OF WAY CHECKED CADD FILE NAME

PLAN SURVEYED PLOTTED CHECKED BY: DATE
 NOTE BOOK NO. OF WAY CHECKED CADD FILE NAME

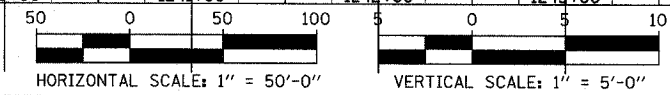
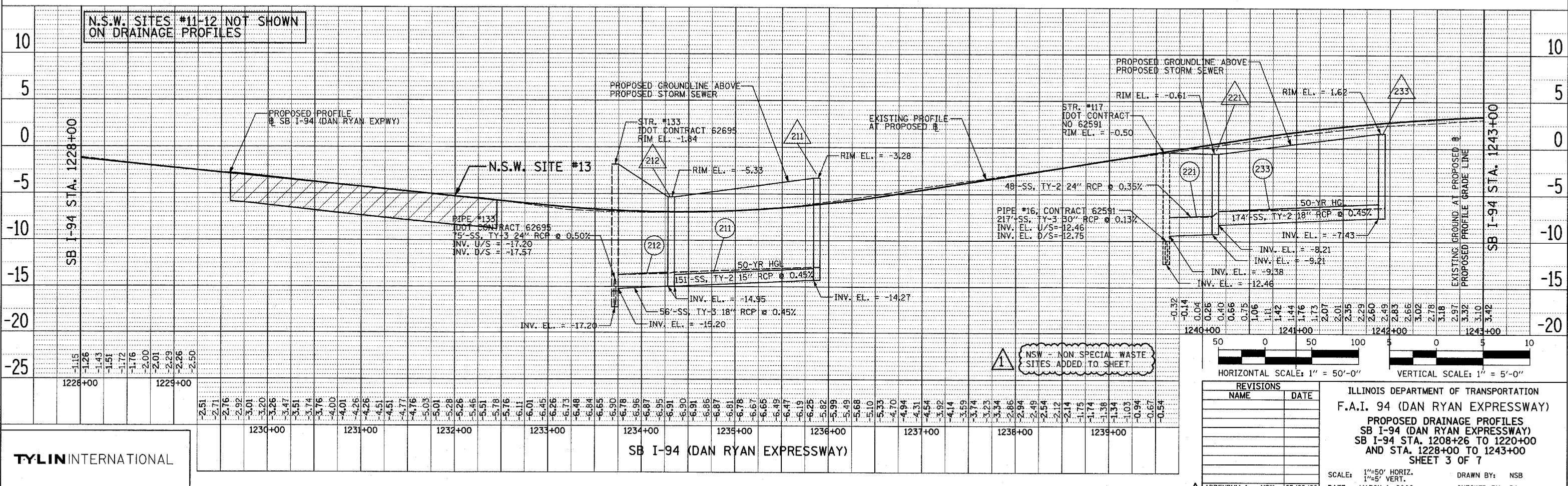
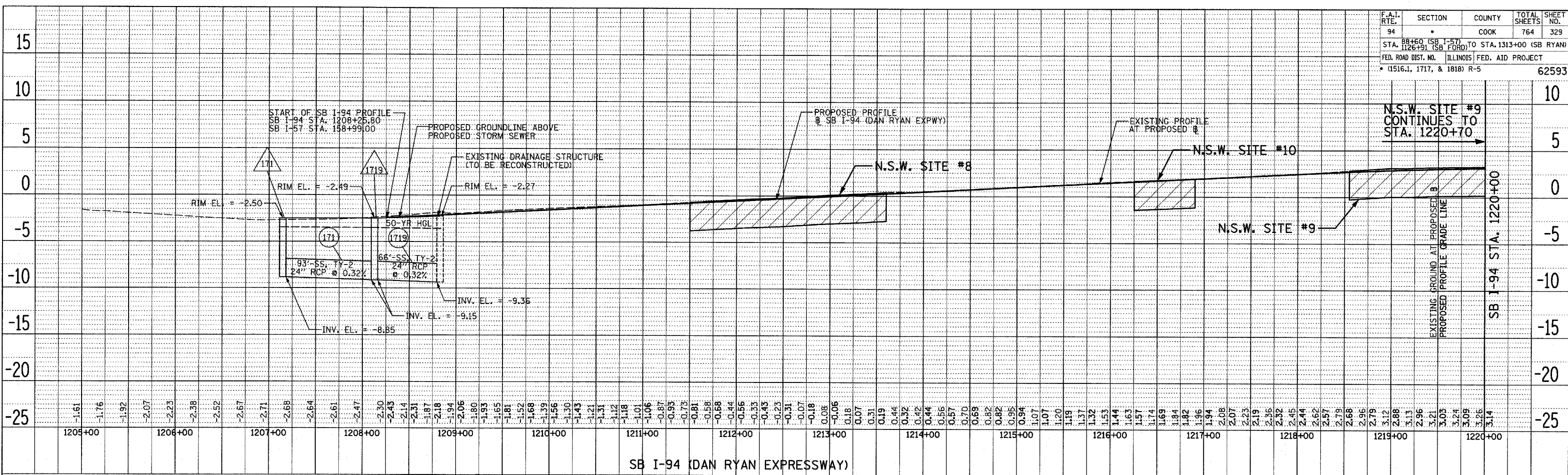

REVISIONS	
NAME	DATE

ILLINOIS DEPARTMENT OF TRANSPORTATION
 F.A.I. 94 (DAN RYAN EXPRESSWAY)
 PROPOSED DRAINAGE PROFILES
 SB I-94 (DAN RYAN EXPRESSWAY)
 SB I-94 STA. 1208+26 TO 1220+00
 AND STA. 1228+00 TO 1243+00
 SHEET 3 OF 7

SCALE: 1"=50' HORIZ.
 1"=5' VERT.
 DATE: MARCH 1, 2006
 DRAWN BY: NSB
 CHECKED BY: DA

TYLIN INTERNATIONAL

DATE: _____
 BY: _____
 SURVEYED: _____
 PLOTTED: _____
 CHECKED: _____
 NO. OF WAY CHECKED: _____
 NOTE BOOK NO.: _____
 CAD FILE NAME: _____

DATE: _____
 BY: _____
 SURVEYED: _____
 PLOTTED: _____
 CHECKED: _____
 NO. OF WAY CHECKED: _____
 NOTE BOOK NO.: _____
 CAD FILE NAME: _____

05/05/2006 03:56:05 PM

F.A.I. RTE.	SECTION	COUNTY	TOTAL SHEETS	SHEET NO.
94		COOK	764	330
STA. 125+00 (SB I-94) TO STA. 1270+00 (SB RYAN)				
FED. ROAD DIST. NO. ILLINOIS FED. AID PROJECT				
• (1516.1, 1717, & 1818) R-5				
				62593

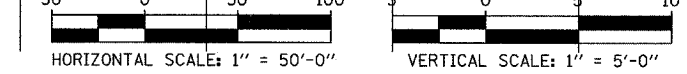
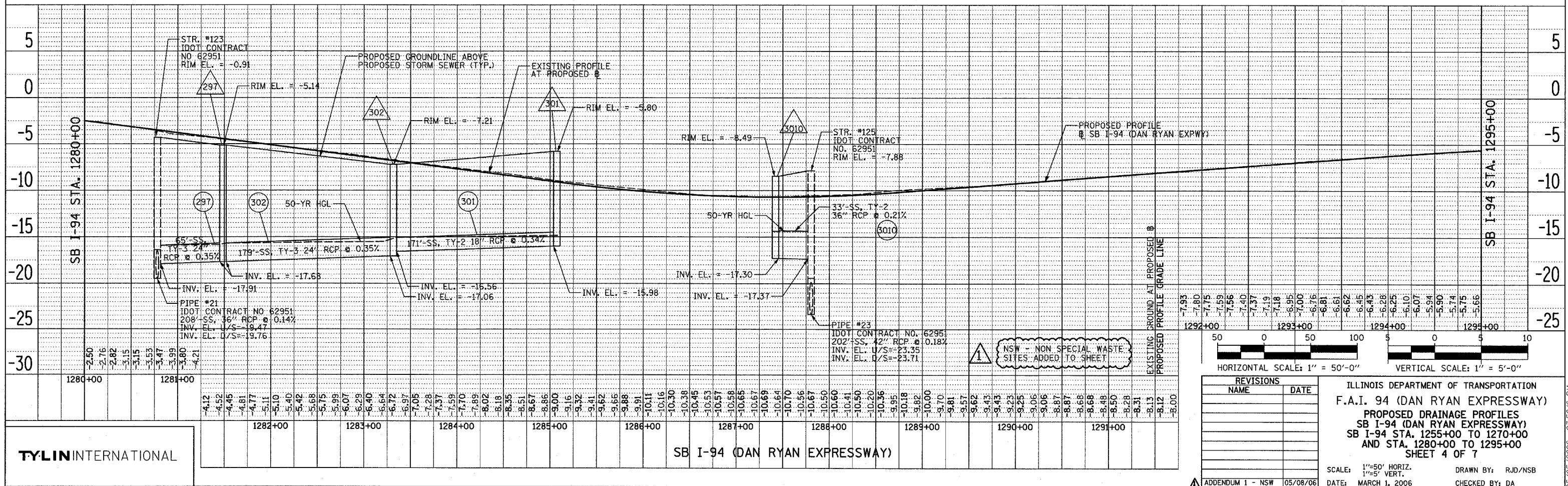
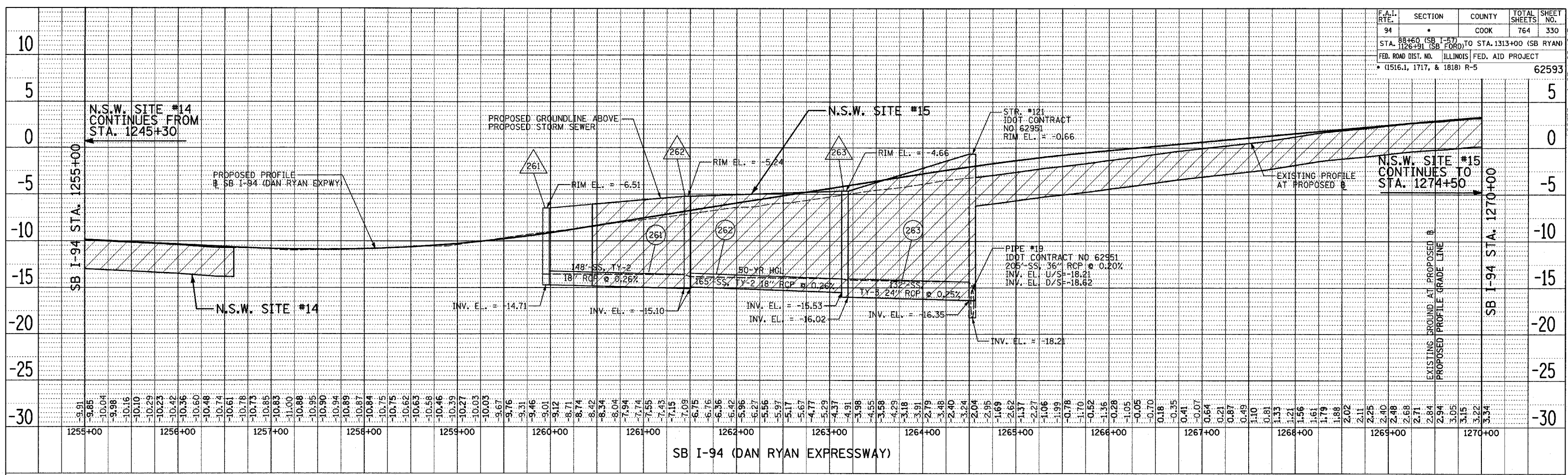

REVISIONS	
NAME	DATE

ILLINOIS DEPARTMENT OF TRANSPORTATION
 F.A.I. 94 (DAN RYAN EXPRESSWAY)
 PROPOSED DRAINAGE PROFILES
 SB I-94 (DAN RYAN EXPRESSWAY)
 SB I-94 STA. 1255+00 TO 1270+00
 AND STA. 1280+00 TO 1295+00
 SHEET 4 OF 7

SCALE: 1"=50' HORIZ.
 1"=5' VERT.
 DATE: MARCH 1, 2006

DRAWN BY: RJD/NSB
 CHECKED BY: DA

TYLIN INTERNATIONAL

DATE: _____
 BY: _____
 CHECKED: _____
 DATE: _____

DATE: _____
 BY: _____
 CHECKED: _____
 DATE: _____

05/05/2006 03:56:16 PM

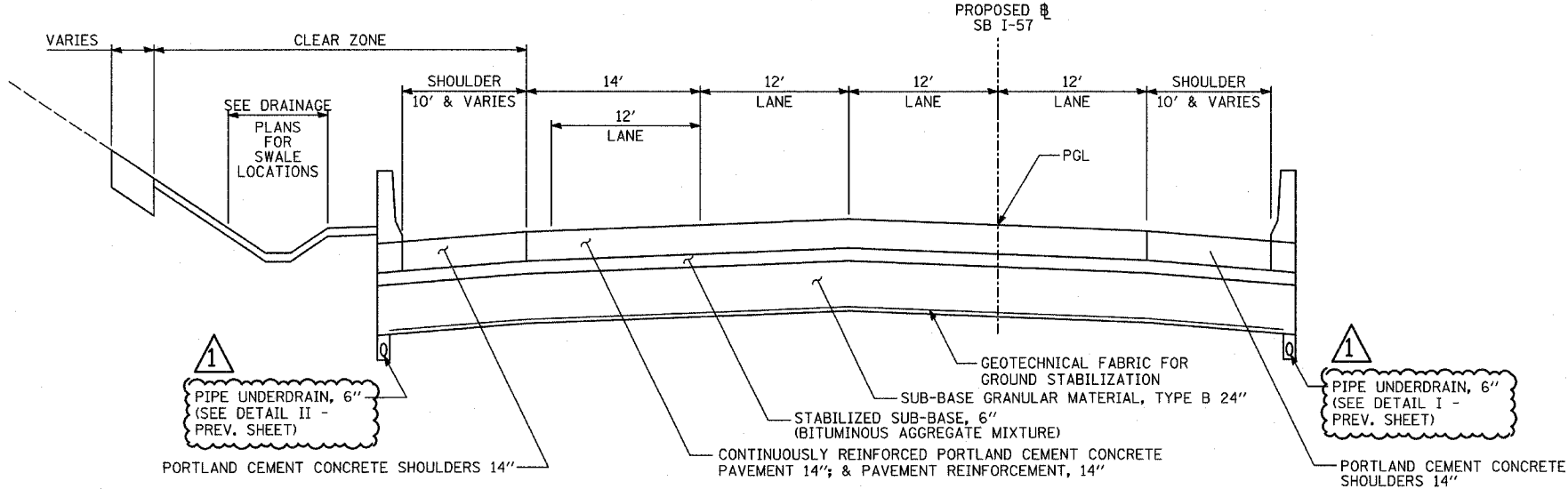

PROPOSED SB I-57 MAINLINE PAVEMENT
LOCATIONS VARY BETWEEN PARNELL AVENUE AND WENTWORTH AVENUE

- NOTES:**
- (1) GEOTECHNICAL FABRIC FOR GROUND STABILIZATION SHALL BE PLACED SUCH THAT IT EXTENDS TO THE EDGE OF THE TRENCH AND OVERLAPS THE FILTER FABRIC BY A MINIMUM OF 6". AT NO TIME SHALL THE GEOTECHNICAL FABRIC FOR GROUND STABILIZATION BE OVER OR COVER THE UNDERDRAIN TRENCH.
 - (2) NO CONSTRUCTION TRAFFIC SHALL BE ALLOWED ON THE TRENCH UNTIL A MINIMUM OF 12" OF COMPACTED SUB-BASE IS PROVIDED.
 - (3) THE PIPE UNDERDRAIN TRENCH SHALL BE LINED WITH FILTER FABRIC ON THE BOTTOM AND SIDES OF THE TRENCH. THE TOP OF THE TRENCH MUST NOT BE COVERED WITH ANY FABRIC.
 - (4) FILTER FABRIC, FABRIC ENVELOPE, AND CA-16 AGGREGATE ARE INCLUDED IN THE UNIT COST OF PIPE UNDERDRAIN, 6".
 - (5) CONTRACTOR SHALL FLUSH PIPE UNDERDRAIN WITH WATER TO INSURE UNDERDRAIN IS FUNCTIONING PROPERLY PRIOR TO THE PLACEMENT OF STABILIZED SUB-BASE. PRIOR TO COMMENCING THIS WORK, THE CONTRACTOR SHALL PROVIDE THE ENGINEER WITH HIS APPROACH AND METHODS FOR COMPLETING THIS WORK, FOR THE ENGINEER'S REVIEW AND APPROVAL. THE COST OF FLUSHING THE PIPE IS INCLUDED IN THE UNIT COST OF PIPE UNDERDRAIN, 6".

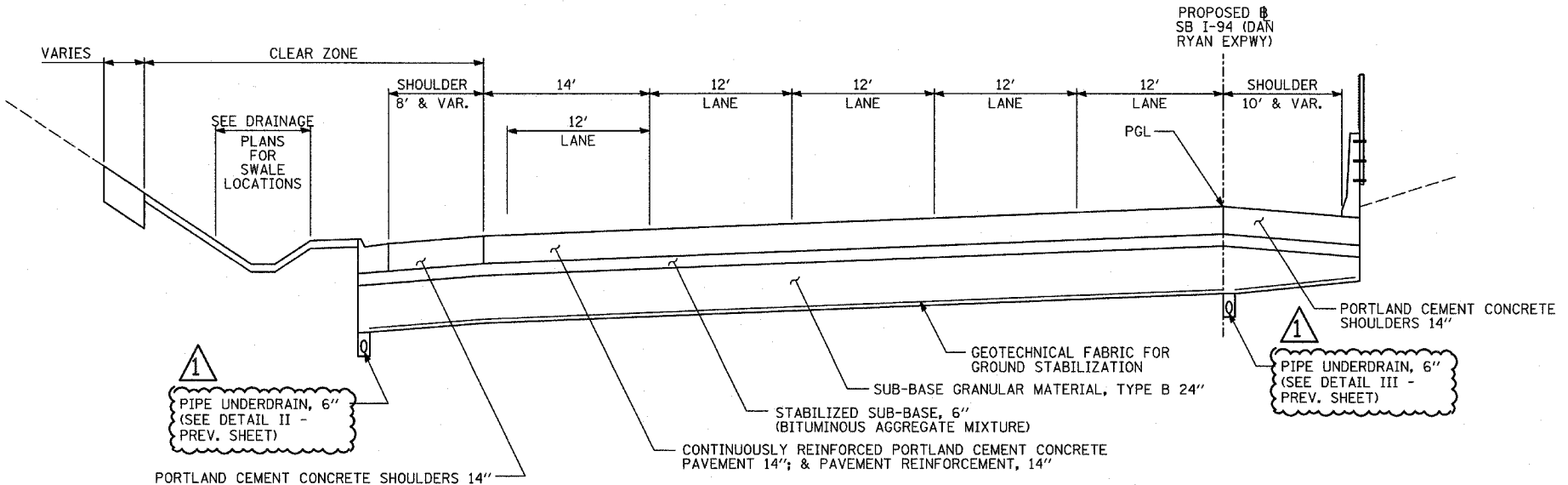

PROPOSED SB I-94 MAINLINE PAVEMENT
BETWEEN SB I-94/I-57 SPLIT AND 95TH STREET

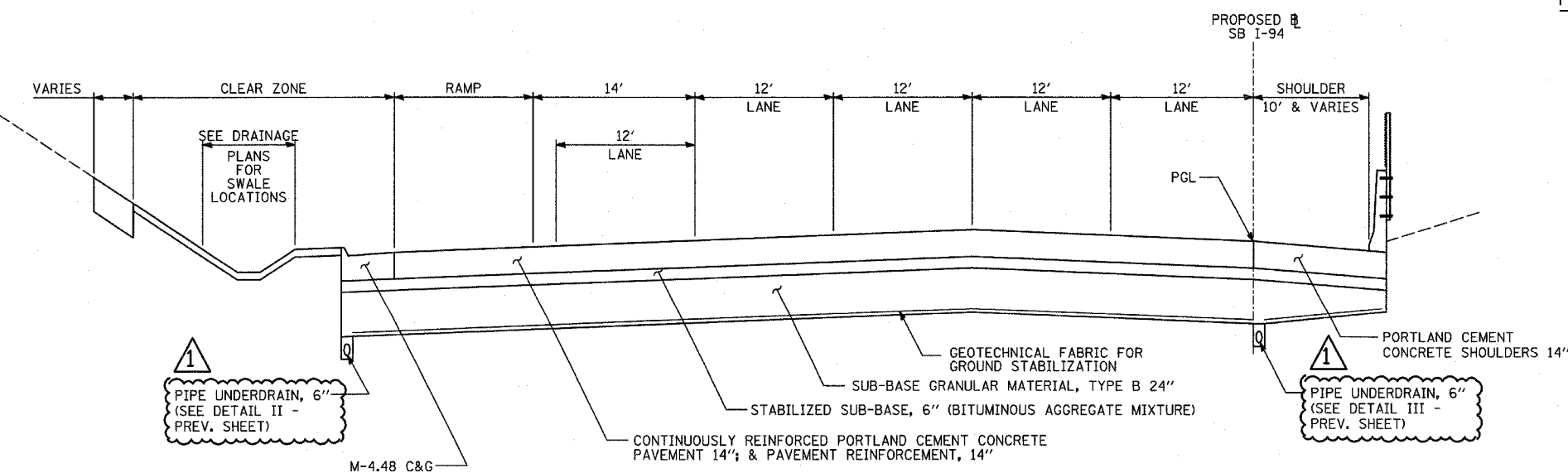

PROPOSED SB I-94 MAINLINE PAVEMENT
LOCATIONS VARY BETWEEN 95TH STREET AND 79th STREET

REVISIONS

NAME	DATE

ILLINOIS DEPARTMENT OF TRANSPORTATION
F.A.I. 94 (DAN RYAN EXPRESSWAY)

**PIPE UNDERDRAINS ALONG
I-57 AND I-94 DETAILS
SHEET 2 OF 2**

SCALE: NONE DRAWN BY: BK
DATE: MARCH 1, 2006 CHECKED BY: DA

ADDENDUM 1 05/08/06

DRAINAGE STRUCTURE SCHEDULE

STRUCTURE NUMBER	STATION	OFFSET	STRUCTURE TYPE		DIA.	FRAME & LID	TOP OF FRAME	N INV.	E INV.	S INV.	W INV.
			MH	CB							
6111	120+34.59	27.6 RT		C	2'	T1F OL	-0.10				-7.33
71	123+31.04	57.2 LT	A		5'	T1F CL	1.95		-9.58	-6.08	-9.07
72	125+86.73	58.6 LT	A		5'	T1F CL	3.20	-3.30 (E)	-10.19	-3.85	-9.94
73	127+21.28	57.9 LT	A		5'	T1F CL	4.05		-10.35		-10.35
74	123+42.35	22.9 RT		A	4'	T20 F&G	3.17	-5.50	-5.50		
75	123+42.94	48.0 LT		A	4'	T20 F&G	0.07	-6.03		-5.78	
76	125+85.73	26.1 RT		A	4'	T20 F&G	5.30	-3.52			
77	125+86.73	48.0 LT		A	4'	T20 F&G	2.02	-3.81		-3.81	
78	125+98.12	51.6 LT		C	2'	T1F OL	2.30				-3.27
79	123+57.84	28.6 RT		C	2'	T1F OL	3.08				-5.43
91	128+55.33	58.6 LT	A		6'	T1F CL	4.70		-2.65	-10.51	-10.51
92	132+13.35	57.2 LT	A		5'	T1F CL	3.95		-6.35	-3.71	-6.35
93	129+40.68	48.0 LT		A	4'	T20 F&G	3.53	-2.30			-2.30
94	341+60.13	25.7 LT		A	4'	T20 F&G	5.15	-2.50			
95	131+09.39	42.7 LT		A	4'	T20 F&G	2.95	-3.15		-2.90	
96	132+13.61	10.0 RT		A	4'	T20 F&G	4.45	-3.45			
97	132+13.62	47.6 LT		A	4'	T20 F&G	2.16	-3.67		-3.67	
98	406+30.19	44.6 RT	A		6'	T1F CL	7.70	-10.58			-10.58
99	128+45.64	105.8 RT	DROP		7'	T1F CL	4.62	-10.72	-14.72	-10.72	
910	128+64.53	107.5 RT	DROP		7'	T1F CL	4.68	-18.74			-14.74
911	128+67.20	94.7 RT	A(2)		6'	T1F CL	5.40	-18.75		-18.75	
912	128+69.90	82.3 RT	DROP		8'	T1F CL	6.01	-24.99		-18.76	
913	406+19.68	44.6 RT	PLUG						-10.57		
914	132+81.90	48.0 LT		A	4'	T20 F&G	1.78	-4.05			
915	131+51.39	54.8 LT	A(2)		6'	T1F CL	6.91	-6.52		-6.52	
916	129+50.00	51.4 LT		C	2'	T1F OL	3.67			-2.26	
111	136+44.35	54.5 LT	A(6)		5'	T1F CL	1.85	-3.65	-3.65	-3.86	
112	135+00.49	56.1 LT	A(6)		4'	T1F CL	1.13	-4.40	-4.40	-4.40	
113	133+51.32	56.8 LT	A(6)		5'	T1F CL	1.39	-4.96	-4.77	-5.96	
114	134+31.09	10.0 RT		A	4'	T20 F&G	3.66				-3.86
115	134+21.13	10.0 RT		A	4'	T20 F&G	3.66	-3.89	-3.89		-3.89
116	134+11.17	10.0 RT		A	4'	T20 F&G	3.66		-3.86		
117	NOT USED	-	-	-	-	-	-	-	-	-	-
118	NOT USED	-	-	-	-	-	-	-	-	-	-
119	134+21.75	48.0 LT		A	4'	T20 F&G	1.27	-4.36	-4.11	-4.11	-4.11
1110	134+32.00	48.0 LT		A	4'	T20 F&G	1.27	-4.08			-4.08
1111	134+11.50	48.0 LT		A	4'	T20 F&G	1.27		-4.08		
1112	135+00.52	10.0 RT		A	4'	T20 F&G	3.79	-4.15			
1113	135+00.52	48.0 LT		A	4'	T20 F&G	1.46	-4.37		-4.37	
1114	136+50.68	10.0 RT		A	4'	T20 F&G	4.54	-3.40			
1115	136+50.68	48.0 LT		A	4'	T20 F&G	2.21			-3.62	-3.62
1116	138+00.01	10.0 RT		A	4'	T20 F&G	5.28	-2.66		-2.66	
1117	138+00.01	48.0 LT		A	4'	T20 F&G	2.95	-2.88		-2.88	
1118	133+51.40	48.0 LT		A	4'	T20 F&G	1.42				-4.74
1119	134+29.33	54.3 LT		C	2'	T1F OL	0.70			-4.05	
1120	134+21.79	57.9 LT	A(6)		5'	T1F CL	1.38	-4.69	-4.40	-4.70	
1121	136+55.15	55.1 LT		C	2'	T1F OL	1.90				-3.62
121	139+49.73	10.0 RT		A	4'	T20 F&G	5.76				-2.18
122	139+51.19	48.0 LT		A	4'	T20 F&G	3.43	-2.40	-2.40		
123	142+05.53	10.0 RT		A	4'	T20 F&G	4.76		-2.46		-2.46
124	138+15.00	20.6 RT		C	2'	T1F OL	4.04				-2.59
125	142+22.00	23.6 RT		C	2'	T1F OL	2.98				-2.37
126	140+51.42	51.6 LT		C	2'	T1F OL	3.38	-1.47			
141	146+73.32	55.5 LT	A(6)		5'	T1F CL	0.26	-11.88	-3.61	-12.38	
142	146+30.95	10.0 RT		A	4'	T20 F&G	2.54				-3.29
143	1168+71.92	34.0 RT		A(7)	4'	T20 F&G	1.27				-4.09

STORM SEWER SCHEDULE

PIPE NUMBER	UPSTREAM STATION	DOWNSTREAM STATION	TYPE	DIA. (IN)	LENGTH (FT)	SLOPE %	T.B. (CU.YD)
612	121+92.37	121+92.35	2	12	63	0.44	16.9
613	121+92.35	121+92.51	2	15	7	0.44	0.6
614	120+29.65	120+20.42	2	12	8	0.44	0.0
6111	120+34.59	120+20.42	2	12	14	0.44	4.4
6112	117+26.88	117+32.86	2	12	8	0.44	0.3
71	123+31.04	125+86.73	3	27	243	0.15	0.0
72	125+86.73	127+21.28	3	30	126	0.13	0.0
73	127+21.28	128+55.33	3	30	125	0.13	0.0
74	123+42.35	123+42.94	2	12	63	0.44	18.8
75	123+42.94	123+31.04	2	15	12	0.44	1.7
76	125+85.73	125+86.73	2	12	67	0.44	20.8
77	125+86.73	125+86.73	2	12	9	0.44	0.6
78	125+98.12	125+86.73	2	12	10	0.44	0.0
79	123+57.84	123+42.35	2	12	15	0.44	10.4
91	128+55.33	128+45.64	JIP	30	159	0.13	0.0
92	132+13.35	131+51.39	3	24	55	0.30	0.0
93	129+40.68	128+55.33	2	12	79	0.44	7.8
94	341+60.13	131+09.39	2	12	90	0.44	22.3
95	131+09.39	131+37.00	2	15	25	0.44	10.9
96	132+13.61	132+13.62	2	12	50	0.44	12.9
97	132+13.62	132+13.35	2	12	8	0.44	2.0
98	406+30.19	128+45.64	JIP	30	106	0.13	0.0
99	128+45.64	128+64.53	4	42	13	0.13	0.0
910	128+64.53	128+67.20	5	42	7	0.14	0.0
911	128+67.20	128+69.90	5	42	8	0.13	0.0
912	128+69.90	128+72.70	6	42	6	0.17	0.0
913	406+19.69	406+30.19	3	30	8	0.13	0.0
914	132+81.90	132+81.94	2	12	11	0.44(4)	0.6
915	131+51.39	131+37.00	3	24	8	0.30	0.0
916	129+50.00	129+40.68	2	12	8	0.44	0.6
111	136+44.35	135+00.49	2	18	136	0.40	0.0
112	135+00.49	134+21.79	2	18	72	0.40	0.0
113	133+51.32	132+13.35	2	24	129	0.30	0.0
114	134+31.09	134+21.13	2	15	6	0.44	2.0
115	134+21.13	134+21.75	2	15	50	0.44	10.7
116	134+11.17	134+21.13	2	15	6	0.44	2.0
117	NOT USED	-	-	-	-	-	-
118	NOT USED	-	-	-	-	-	-
119	134+21.75	134+21.79	2	18	8	0.44	0.0
1110	134+32.00	134+21.75	2	15	6	0.44	0.5
1111	134+11.50	134+21.75	2	15	6	0.44	0.5
1112	135+00.52	135+00.52	2	12	50	0.44	12.9
1113	135+00.52	135+00.49	2	12	7	0.44	0.4
1114	136+50.68	136+50.68	2	12	50	0.44	12.9
1115	136+50.68	134+11.50	2	12	7	0.44	0.6
1116	138+00.01	138+00.01	2	12	50	0.44	12.9
1117	138+00.01	137+83.89	2	12	13	0.44	1.8
1118	133+51.40	133+51.32	2	12	7	0.44	0.9
1119	134+29.33	134+32.00	2	12	6	0.44	0.0
1120	134+21.79	133+51.32	2	18	64	0.40	0.0
1121	136+55.15	136+44.35	2	12	7	0.44	0.0
121	139+49.73	139+51.19	2	12	50	0.44	12.9
122	139+51.19	139+85.08	2	12	30	0.44	4.7
123	142+05.53	142+08.33	2	12	43	0.44	8.3
124	138+15.00	138+00.01	2	12	17	0.44	3.0
125	142+22.00	142+05.53	2	12	20	0.44	1.6

F.A.I. RTE.	SECTION	COUNTY	TOTAL SHEETS	SHEET NO.
94	*	COOK	764	349

STA. 88+60 (SB I-57) TO STA. 1126+91 (SB FORD)
 STA. 1126+91 (SB FORD) TO STA. 1313+00 (SB RYAN)
 FED. ROAD DIST. NO. ILLINOIS FED. AID PROJECT
 * (1516.1, 1717, & 1818) R-5

NOTES:

- INDICATES INLET TYPE A, 2' DIAMETER, TYPE 20 FRAME & GRATE.
- INDICATES MANHOLE, TYPE A, 6' DIAMETER, TYPE 1 FRAME, CLOSED LID, RESTRICTOR PLATE.
- INDICATES SEWER LATERAL WITH 45° CONNECTION. SEE SHEET "DETAIL OF STORM SEWER CONNECTIONS TO SEWER."
- INDICATES SEWER LATERAL WITH 30° CONNECTION. SEE SHEET "DETAIL OF STORM SEWER CONNECTIONS TO SEWER."
- INDICATES SEWER LATERAL WITH 60° CONNECTION. SEE SHEET "DETAIL OF STORM SEWER CONNECTIONS TO SEWER."
- INDICATES MANHOLE TYPE A WITH FLAT SLAB TOP, IDOT STANDARD 602601.
- INDICATES CATCH BASIN REQUIRING TEMPORARY SOIL RETENTION SYSTEM WITH INSTALLATION.
- ALL STRUCTURE ELEVATIONS IN RESURFACED AREAS COME FROM AERIAL SURVEY AND SHOULD BE VERIFIED IN THE FIELD AND ADJUSTED TO MATCH EXISTING CONDITIONS.

CASING SIZES

PIPE SIZE	CASING SIZE (OD)*	CASING WALL THICKNESS
12"	30"	0.500"
24"	42"	0.625"
30"	48"	0.688"
36"	48"	0.688"

*ALL STEEL CASING SHALL MEET OR EXCEED ASTM A-139, GRADE B.
 SEE THE DRAINAGE & UTILITY PLANS FOR LOCATION OF ALL STRUCTURES.
 CATCH BASIN STATIONS ARE MEASURED TO CENTER OF STRUCTURE.
 CATCH BASIN OFFSETS ARE MEASURED TO FLOWLINE OF CASTING. (SEE BELOW)
 FLOWLINE OF CASTING IS LOCATED AT 1/2 OF STRUCTURE FOR CATCH BASINS LOCATED IN SWALE AND GORE AREAS.

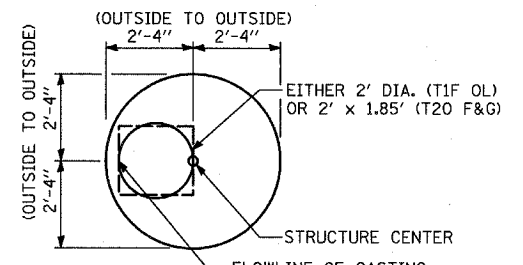

CATCH BASIN (PRECAST REINFORCED CONCRETE SECTION)

MANHOLE STATIONS AND OFFSETS ARE MEASURED TO CENTER OF STRUCTURE. (SEE BELOW)

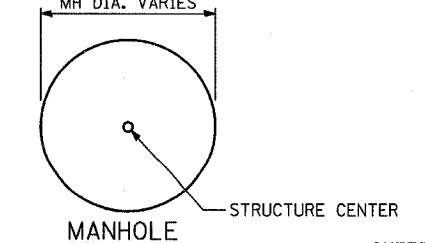

MANHOLE

REVISIONS	
NAME	DATE

ILLINOIS DEPARTMENT OF TRANSPORTATION
 F.A.I. 94 (DAN RYAN EXPRESSWAY)
 DRAINAGE STRUCTURE SCHEDULE
 SCALE: NONE
 DATE: MARCH 1, 2006
 DRAWN BY: RD
 CHECKED BY: DA

DRAINAGE STRUCTURE SCHEDULE

STRUCTURE NUMBER	STATION	OFFSET	STRUCTURE TYPE		DIA.	FRAME & LID	TOP OF FRAME	N INV.	E INV.	S INV.	W INV.
			MH	CB							
144	1170+41.89	34.0 RT		A(7)	4'	T20 F&G	0.82				-5.40
145	147+26.35	48.0 LT		A	4'	T20 F&G	0.32	-5.78			-6.03
146	143+81.44	10.0 RT		A	4'	T20 F&G	3.89				-1.94
151	151+49.24	109.3 LT	A		5'	T1F CL	12.44	-10.10		-10.10	
152	150+69.33	58.6 LT	A		5'	T1F CL	-0.91	-10.36	-7.53	-10.36	
153	149+07.94	54.1 LT	A		5'	T1F CL	-0.89	-10.82	-6.71	-11.32	-6.71
154	149+00.66	56.1 LT		C	2'	T1F OL	-0.87	-6.69			
155	1172+27.23	34.0 RT		A(7)	4'	T20 F&G	1.13				-6.11
156	149+08.47	48.0 LT		A	4'	T20 F&G	-0.59	-6.44			-6.69
157	150+71.04	34.0 RT		A(7)	4'	T20 F&G	1.41				-6.91
158	150+68.58	48.0 LT		A	4'	T20 F&G	-1.39	-7.24			-7.49
161	155+26.80	55.4 LT	A		4'	T1F CL	-1.25	-7.89	-7.89		
162	154+14.92	58.5 LT	A		4'	T1F CL	-2.71	-8.41	-8.41	-8.41	
163	152+29.99	54.4 LT	A		5'	T1F CL	-2.52	-9.29	-8.32	-8.32	-9.79
164	152+05.35	109.7 LT	A		5'	T1F CL	12.96		-9.95	-9.95	
165	155+30.82	31.5 RT		A(7)	4'	T20 F&G	-1.03				-7.55
166	155+31.10	42.7 LT		A	4'	T20 F&G	-3.16	-7.84			-7.84
167	154+17.19	31.5 RT		A(7)	4'	T20 F&G	-0.20				-7.55
168	154+15.00	48.0 LT		A	4'	T20 F&G	-3.12	-8.37	-7.87		-8.37
169	152+31.21	32.1 RT		A(7)	4'	T20 F&G	0.71				-7.73
1610	152+30.49	48.0 LT		A	4'	T20 F&G	-2.20		-8.05		-8.30
1611	152+21.55	55.2 LT		C	2'	T1F OL	-2.48	-8.30			
1612	157+50.05	39.0 LT		A(1)	2'	T20 F&G	-3.34	-5.17			
1613	157+70.05	39.0 LT		A(1)	2'	T20 F&G	-3.34			-5.17	
1614	157+56.34	39.0 LT		A	4'	T20 F&G	-3.35	-5.23	-6.73	-5.21	
1615	NOT USED	-	-	-	-	-	-	-	-	-	-
1616	157+63.93	30.8 RT		A(7)	4'	T20 F&G	-2.41	-8.03		-8.03	
1617	157+53.41	31.1 RT		A(7)	4'	T20 F&G	-2.42	-8.00			
1618	NOT USED	-	-	-	-	-	-	-	-	-	-
1619	155+64.53	40.6 LT		A	4'	T20 F&G	-3.06	-7.70		-7.70	
1620	155+93.95	37.6 LT		A	4'	T20 F&G	-3.06			-7.57	
1621	154+69.08	48.0 LT		A	4'	T20 F&G	-3.35			-8.15	-8.15
1622	154+69.00	54.6 LT		C	2'	T1F OL	-3.73		-8.12		
171	157+87.88	24.5 RT	A(6)		5'	T1F CL	-2.50	-8.85		-8.10	-7.02
172	NOT USED	-	-	-	-	-	-	-	-	-	-
173	NOT USED	-	-	-	-	-	-	-	-	-	-
174	NOT USED	-	-	-	-	-	-	-	-	-	-
175	158+37.62	39.0 LT		A(1)	2'	T20 F&G	-3.04	-5.62			
176	158+34.99	29.2 RT		C(7)	2'	T20 F&G	-2.65	-8.49			
177	158+90.71	39.0 LT		A(1)	2'	T20 F&G	-2.89		-5.84	-5.84	
178	1208+84.48	63.0 LT		A(1)	2'	T20 F&G	-2.56	-5.60	-5.60		
179	1209+44.48	63.0 LT		A(1)	2'	T20 F&G	-2.26			-5.34	
1710	1210+78.44	4.3 RT		A(7)	4'	T20 F&G	-1.34				-7.23
1711	1210+16.13	63.8 LT		A	4'	T20 F&G	-1.92	-8.17			
1712	1210+78.55	66.2 LT		A	4'	T20 F&G	-1.68	-7.51	-7.51		-7.51
1713	1211+44.85	68.7 LT		A	4'	T20 F&G	-1.45			-7.23	
1714	1212+06.71	4.9 RT		A(7)	4'	T20 F&G	-0.72	-6.70			-7.04
1715	1212+08.00	71.1 LT		A	4'	T20 F&G	-1.24	-7.09	-7.34	-6.34	-7.34
1716	1212+98.11	72.0 LT		A	4'	T20 F&G	-0.86			-6.71	
1717	1212+90.40	4.6 RT		A(7)	4'	T20 F&G	-0.29			-6.35	
1718	1209+47.87	4.0 RT		C(7)	2'	T20 F&G	-1.98			-7.81	
1719	158+85.92	24.5 RT	A(6)		5'	T1F CL	-2.49	-9.15		-9.15	-8.08
1720	NOT USED	-	-	-	-	-	-	-	-	-	-
1721	1212+00.00	77.3 LT		C	2'	T1F OL	-1.67	-6.30			
1722	157+75.42	30.4 RT		A(7)	4'	T20 F&G	-2.40	-8.06		-8.06	
181	1213+73.49	6.9 RT		A(7)	4'	T20 F&G	0.03				-6.26

STORM SEWER SCHEDULE

PIPE NUMBER	UPSTREAM STATION	DOWNSTREAM STATION	TYPE	DIA. (IN)	LENGTH (FT)	SLOPE %	T.B. (CU.YD)
126	140+51.42	140+59.96	2	12	17	0.44(5)	0.0
141	146+73.32	145+40.93	3	36	125	0.20	68.6
142	146+30.95	146+73.32	2	12	72	0.44	3.3
143	1168+71.92	145+65.63	2	12	119	0.44	14.5
144	1170+41.89	147+26.35	2	12	87	0.44	16.9
145	147+26.35	147+26.19	2	15	11	0.44(3)	0.6
146	143+81.44	143+81.29	2	12	45	0.44	3.6
147	NOT USED	-	-	-	-	-	-
148	NOT USED	-	-	-	-	-	-
151	151+49.24	150+69.33	5	24	88	0.30	0.0
152	150+69.33	149+07.94	2	24	153	0.30	0.0
153	149+07.94	146+73.32	2	30	225	0.25	0.0
154	149+00.66	149+07.94	2	12	4	0.44	0.0
155	1172+27.23	149+08.47	2	12	76	0.44	17.1
156	149+08.47	149+07.94	2	15	4	0.44	0.5
157	150+71.04	150+68.58	2	12	75	0.44	20.9
158	150+68.58	150+69.33	2	15	9	0.44	0.5
161	155+26.80	154+14.92	2	18	106	0.50	0.0
162	154+14.92	152+29.99	2	18	177	0.50	0.0
163	152+29.99	152+05.35	5	24	56	0.30	0.0
164	152+05.35	151+49.24	JIP	24	49	0.30	0.0
165	155+30.82	155+31.10	2	12	67	0.44	8.2
166	155+31.10	155+26.80	2	15	12	0.44	0.4
167	154+17.19	154+15.00	2	12	72	0.44	12.5
168	154+15.00	154+14.92	2	18	9	0.44	0.2
169	152+31.21	152+30.49	2	12	73	0.44	21.1
1610	152+30.49	152+29.99	2	15	4	0.44	0.5
1611	152+21.55	152+29.99	2	12	5	0.44	0.0
1612	157+50.05	157+56.34	2	12	4	1.00	0.0
1613	157+70.05	157+56.34	2	12	11	1.00	0.0
1614	157+56.34	157+87.88	2	15	65	0.44	0.0
1615	NOT USED	-	-	-	-	-	-
1616	157+63.93	157+75.42	2	15	8	0.44	1.0
1617	157+53.41	157+63.93	2	15	7	0.44	0.8
1618	NOT USED	-	-	-	-	-	-
1619	155+64.53	155+26.80	2	12	30	0.44	4.0
1620	155+93.95	155+64.53	2	12	26	0.44	0.4
1621	154+69.08	154+15.00	2	12	50	0.44	3.5
1622	154+69.00	154+69.08	2	12	6	0.44	0.1
171	157+87.88	158+85.92	2	24	93	0.32	16.3
172	NOT USED	-	-	-	-	-	-
173	NOT USED	-	-	-	-	-	-
174	NOT USED	-	-	-	-	-	-
175	158+37.62	158+90.71	2	12	52	0.44	0.0
176	158+34.99	158+39.61	2	12	5	0.44	0.8
177	158+90.71	158+85.92	2	12	59	0.44	0.0
178	1208+84.48	1208+82.79	2	12	61	0.44	4.2
179	1209+44.48	1208+84.48	2	12	58	0.44	0.0
1710	1210+78.44	1210+78.55	2	12	63	0.44	9.6
1711	1210+16.13	1210+37.33	2	12	24	0.44	4.7
1712	1210+78.55	1210+78.56	2	12	12	0.44	2.1
1713	1211+44.85	1210+78.55	2	12	63	0.44	8.9
1714	1212+06.71	1212+08.00	2	15	69	0.44	11.5
1715	1212+08.00	1212+07.56	2	15	7	0.44	0.8
1716	1212+98.11	1212+08.00	2	12	87	0.44	9.7
1717	1212+90.40	1212+06.71	2	12	80	0.44	13.8

F.A.I. RTE.	SECTION	COUNTY	TOTAL SHEETS	SHEET NO.
94		COOK	764	350

STA. 88+60 (SB I-57) TO STA. 1313+00 (SB RYAN)
 STA. 1126+91 (SB FORD) TO STA. 1313+00 (SB RYAN)
 FED. ROAD DIST. NO. ILLINOIS FED. AID PROJECT
 * (1516.1, 1717, & 1818) R-5
62593

NOTES:

- INDICATES INLET TYPE A, 2' DIAMETER, TYPE 20 FRAME & GRATE.
- INDICATES MANHOLE, TYPE A, 6' DIAMETER, TYPE 1 FRAME, CLOSED LID, RESTRICTOR PLATE.
- INDICATES SEWER LATERAL WITH 45° CONNECTION. SEE SHEET "DETAIL OF STORM SEWER CONNECTIONS TO SEWER."
- INDICATES SEWER LATERAL WITH 30° CONNECTION. SEE SHEET "DETAIL OF STORM SEWER CONNECTIONS TO SEWER."
- INDICATES SEWER LATERAL WITH 60° CONNECTION. SEE SHEET "DETAIL OF STORM SEWER CONNECTIONS TO SEWER."
- INDICATES MANHOLE TYPE A WITH FLAT SLAB TOP, IDOT STANDARD 602601.
- INDICATES CATCH BASIN REQUIRING TEMPORARY SOIL RETENTION SYSTEM WITH INSTALLATION.
- ALL STRUCTURE ELEVATIONS IN RESURFACED AREAS COME FROM AERIAL SURVEY AND SHOULD BE VERIFIED IN THE FIELD AND ADJUSTED TO MATCH EXISTING CONDITIONS.

CASING SIZES

PIPE SIZE	CASING SIZE (OD)*	CASING WALL THICKNESS
12"	30"	0.500"
24"	42"	0.625"
30"	48"	0.688"
36"	48"	0.688"

*ALL STEEL CASING SHALL MEET OR EXCEED ASTM A-139, GRADE B.
 SEE THE DRAINAGE & UTILITY PLANS FOR LOCATION OF ALL STRUCTURES.

CATCH BASIN STATIONS ARE MEASURED TO CENTER OF STRUCTURE.

CATCH BASIN OFFSETS ARE MEASURED TO FLOWLINE OF CASTING. (SEE BELOW)

FLOWLINE OF CASTING IS LOCATED AT $\frac{1}{2}$ OF STRUCTURE FOR CATCH BASINS LOCATED IN SWALE AND GORE AREAS.

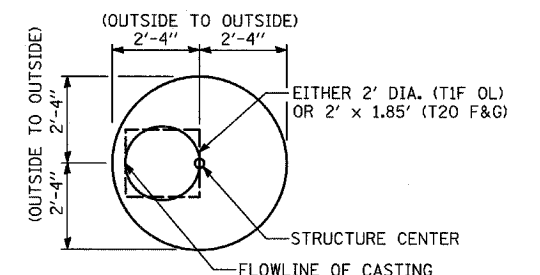

CATCH BASIN

(PRECAST REINFORCED CONCRETE SECTION)

MANHOLE STATIONS AND OFFSETS ARE MEASURED TO CENTER OF STRUCTURE. (SEE BELOW)

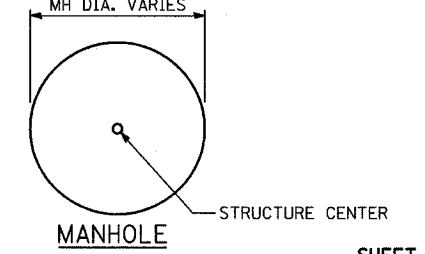

MANHOLE

REVISIONS	
NAME	DATE

ILLINOIS DEPARTMENT OF TRANSPORTATION
 F.A.I. 94 (DAN RYAN EXPRESSWAY)
DRAINAGE STRUCTURE SCHEDULE
 SCALE: NONE
 DATE: MARCH 1, 2006
 DRAWN BY: RD
 CHECKED BY: DA

UNDERDRAIN SCHEDULE

UNDERDRAIN PIPE LIMITS	OFFSET (FT)	PIPE UNDERDRAIN 6" (FT)	CONNECTING STRUCTURE NUMBER	PIPE UNDERDRAIN 6" (SPECIAL) (FT)
*155+64.46 - 155+93.95	37.09 LT - 39.60 LT	29.5	1620	2.0
*155+93.95 - 157+56.34	36.11 LT - 39.00 LT	162.4	1614	2.0
157+50.05 - 157+53.35	36.00 LT - 24.00 RT	60.0	1617	3.0
157+56.34 - 157+63.93	36.00 LT - 24.00 RT	60.0	1616	6.0
157+70.05 - 157+75.42	36.00 LT - 24.00 RT	60.0	1722	8.0
- - - - -	- - - - -	-	-	-
157+53.41 - 157+63.93	24.00 RT - 30.78 RT	10.5	1616	5.0
157+63.93 - 157+75.42	24.00 RT - 30.44 RT	11.5	1722	5.0
- - - - -	- - - - -	-	-	-
152+07.31 - 152+31.17	24.00 RT - 32.06 RT	23.9	169	2.0
152+31.17 - 154+17.19	24.00 RT - 31.50 RT	186.0	167	2.0
154+17.19 - 155+30.82	24.00 RT - 31.49 RT	113.6	165	2.0
155+30.82 - 157+53.35	24.00 RT - 31.08 RT	222.5	1617	2.0
- - - - -	- - - - -	-	-	-
- - - - -	- - - - -	-	-	-
*1210+16.13 - 1206+83.13	60.73 LT - 63.00 LT	333.0	1614	2.0
1210+78.55 - 1210+16.13	66.16 LT - 63.76 LT	62.4	1711	2.0
1211+44.86 - 1210+78.55	68.71 LT - 66.16 LT	66.3	1712	2.0
1212+08.00 - 1211+44.86	71.14 LT - 68.71 LT	63.1	1713	2.0
1212+98.11 - 1212+08.00	72.00 LT - 71.14 LT	90.1	1715	2.0
158+85.92 - 157+87.88	24.00 RT - 24.50 RT	98.0	171	2.0
157+87.88 - 157+75.42	24.00 RT - 30.44 RT	12.5	1722	2.0
159+55.99 - 158+85.92	24.00 RT - 24.50 RT	70.1	1719	2.0
1209+31.93 - 1208+82.79	0.00 RT - 3.21 RT	49.1	EX	2.0
1210+34.78 - 1209+47.87	0.00 RT - 3.98 RT	86.9	1718	2.0
1209+47.87 - 1209+31.93	0.00 RT - 2.75 RT	15.9	EX	2.0
1210+78.44 - 1210+34.78	0.00 RT - 5.13 RT	43.7	EX	2.0
1212+06.73 - 1210+78.44	0.00 RT - 4.27 RT	128.3	1710	2.0
1212+90.41 - 1212+06.73	0.00 RT - 4.91 RT	83.7	1714	2.0
1213+73.50 - 1212+90.41	0.00 RT - 4.60 RT	83.1	1717	2.0
1213+76.02 - 1212+98.11	72.00 LT - 72.00 LT	77.9	1716	2.0
1215+50.57 - 1213+76.02	72.00 LT - 72.00 LT	174.5	182	2.0
1217+24.74 - 1215+50.57	72.00 LT - 72.00 LT	174.2	184	2.0
1219+01.42 - 1217+24.74	72.00 LT - 72.00 LT	176.7	186	2.0
1215+50.04 - 1213+73.50	0.00 RT - 6.89 RT	176.5	181	2.0
1217+23.40 - 1215+50.04	0.00 RT - 7.50 RT	173.4	183	2.0
1218+97.10 - 1217+23.40	0.00 RT - 7.50 RT	173.7	185	2.0
1220+86.66 - 1219+01.42	72.00 LT - 72.00 LT	185.2	191	2.0
1220+86.66 - 1221+74.07	72.00 LT - 72.00 LT	87.4	EX	2.0
1223+71.38 - 1224+11.23	86.31 LT - 84.00 LT	39.8	EX	2.0
1224+11.23 - 1225+71.77	84.01 LT - 74.72 LT	160.5	EX	2.0
1220+86.66 - 1218+97.11	0.00 RT - 7.50 RT	189.6	187	2.0
1220+86.66 - 1222+51.63	0.00 RT - 7.50 RT	165.0	192	2.0
1222+51.63 - 1224+12.19	0.00 RT - 7.50 RT	160.6	193	2.0
1224+12.19 - 1225+71.32	0.00 RT - 9.95 RT	159.1	201	2.0
1225+71.77 - 1227+25.59	74.76 LT - 72.00 LT	153.8	203	2.0
1227+25.59 - 1228+85.75	72.00 LT - 72.00 LT	160.2	205	2.0
1228+85.75 - 1230+61.54	72.00 LT - 72.00 LT	175.8	207	2.0
1231+39.01 - 1230+61.54	72.00 LT - 72.00 LT	77.5	207	2.0
1225+71.32 - 1227+25.59	0.00 RT - 10.00 RT	154.3	202	2.0
1227+25.59 - 1228+88.05	0.00 RT - 10.00 RT	162.5	204	2.0
1228+88.05 - 1230+45.10	0.00 RT - 10.00 RT	157.1	206	2.0

UNDERDRAIN SCHEDULE (CONT.)

UNDERDRAIN PIPE LIMITS	OFFSET (FT)	PIPE UNDERDRAIN 6" (FT)	CONNECTING STRUCTURE NUMBER	PIPE UNDERDRAIN 6" (SPECIAL) (FT)
1230+45.10 - 1232+01.40	0.00 RT - 10.00 RT	156.3	213	2.0
1231+58.17 - 1232+01.40	72.00 LT - 72.00 LT	43.2	214	2.0
*1232+01.40 - 1233+30.59	72.00 LT - 72.00 LT	129.2	216	2.0
1233+30.59 - 1234+27.31	72.00 LT - 72.00 LT	96.7	2116	2.0
1234+27.31 - 1234+27.31	0.00 RT - 62.00 LT	62.0	2116	7.3
1234+37.31 - 1234+37.31	0.00 RT - 62.00 LT	62.0	2115	7.3
1234+47.29 - 1234+47.21	0.00 RT - 62.00 LT	62.0	2114	7.3
1234+27.31 - 1234+37.31	72.00 LT - 72.00 LT	10.0	2115	2.0
1234+47.21 - 1234+37.31	72.47 LT - 72.00 LT	9.9	2115	2.0
1234+27.31 - 1234+37.31	10.00 RT - 10.00 RT	10.0	2118	8.0
1234+47.31 - 1234+37.31	10.00 RT - 10.00 RT	10.0	2118	8.0
1235+15.83 - 1234+47.29	75.11 LT - 72.47 LT	68.5	2114	2.0
*1236+13.19 - 1235+15.83	64.59 LT - 75.11 LT	107.9	2112	2.0
*1237+44.83 - 1236+13.19	66.26 LT - 64.59 LT	131.6	218	2.0
1232+04.40 - 1233+30.69	0.00 RT - 10.00 RT	126.3	215	2.0
1233+30.69 - 1234+27.31	0.00 RT - 10.00 RT	96.6	2120	2.0
1234+80.84 - 1234+47.31	0.00 RT - 10.00 RT	33.5	2119	2.0
1235+15.95 - 1234+80.84	0.00 RT - 10.00 RT	35.1	2110	2.0
1237+30.51 - 1235+15.95	0.00 RT - 10.00 RT	214.6	2111	2.0
*1239+31.93 - 1237+44.83	68.15 LT - 66.26 LT	187.1	227	2.0
1240+21.78 - 1239+31.93	70.39 LT - 68.15 LT	89.9	226	2.0
1241+97.78 - 1240+21.78	74.79 LT - 70.39 LT	176.0	224	2.0
1238+91.62 - 1237+30.51	0.00 RT - 8.29 RT	161.1	228	2.0
1240+21.78 - 1238+91.62	0.00 RT - 9.64 RT	130.2	225	2.0
1241+97.78 - 1240+21.78	0.00 RT - 10.00 RT	176.0	223	2.0
1242+84.85 - 1241+97.78	76.97 LT - 74.79 LT	87.1	232	2.0
1243+77.57 - 1242+84.85	79.29 LT - 76.97 LT	92.7	234	2.0
1243+77.57 - 1245+79.44	79.29 LT - 84.33 LT	201.9	EX	2.0
1246+59.37 - 1245+79.44	86.33 LT - 84.33 LT	79.9	EX	2.0
1243+77.57 - 1241+97.78	0.00 RT - 10.00 RT	179.8	231	2.0
1243+77.57 - 1245+79.44	0.00 RT - 10.00 RT	201.9	235	2.0
1245+79.44 - 1247+22.76	0.00 RT - 10.00 RT	143.3	241	2.0
1248+90.71 - 1249+10.82	72.00 LT - 72.00 LT	20.1	243	2.0
1249+10.82 - 1250+70.49	72.00 LT - 72.00 LT	159.7	245	2.0
1250+70.49 - 1252+30.19	72.00 LT - 72.00 LT	159.7	247	2.0
1252+30.19 - 1254+00.37	72.00 LT - 72.00 LT	170.2	252	2.0
1247+22.76 - 1249+10.82	0.00 RT - 9.93 RT	188.1	242	2.0
1249+10.82 - 1250+70.49	0.00 RT - 8.57 RT	159.7	244	2.0
1250+70.49 - 1252+30.19	0.00 RT - 7.30 RT	159.7	246	2.0
1252+30.19 - 1254+05.13	0.00 RT - 6.01 RT	174.9	251	2.0
1254+00.37 - 1255+70.54	72.00 LT - 72.00 LT	170.2	254	2.0
1255+70.54 - 1257+41.83	72.00 LT - 72.00 LT	171.3	2511	2.0
1257+37.13 - 1257+41.83	0.00 RT - 62.00 LT	62.0	2511	6.7
1257+51.83 - 1257+51.83	0.00 RT - 62.00 LT	62.0	2510	6.7
1257+67.26 - 1257+61.83	0.00 RT - 62.00 LT	62.0	2512	6.7
1257+41.83 - 1257+51.83	72.00 LT - 72.00 LT	10.0	2510	2.0
1257+61.83 - 1257+51.83	72.00 LT - 72.00 LT	10.0	2510	2.0
1257+37.13 - 1257+51.83	6.00 RT - 6.00 RT	14.7	256	4.0
1257+67.26 - 1257+51.83	6.00 RT - 6.00 RT	15.4	256	4.0
1258+27.50 - 1257+61.83	65.39 LT - 72.00 LT	65.7	2512	2.0
1259+91.09 - 1258+27.50	65.38 LT - 65.39 LT	163.6	2514	2.0
1254+05.13 - 1255+70.29	0.00 RT - 5.90 RT	165.2	253	2.0
1255+70.29 - 1257+37.13	0.00 RT - 5.99 RT	166.8	255	2.0
1258+27.98 - 1257+67.26	0.00 RT - 6.01 RT	60.7	257	2.0

LEGEND:

*COORDINATE LOCATION OF PIPE UNDERDRAIN WITH LOCATION OF PROPOSED ELECTRICAL DUCT.



NOTES:

1. IF THE PROPOSED UNDERDRAIN IS IN CONFLICT WITH AN EXISTING UTILITY, THE CONTRACTOR SHALL OUTLET THE UNDERDRAIN TO NEAREST DRAINAGE STRUCTURE.

REVISIONS	
NAME	DATE

ILLINOIS DEPARTMENT OF TRANSPORTATION
F.A.I. 94 (DAN RYAN EXPRESSWAY)
UNDERDRAIN SCHEDULE

WORKING POINTS

Point	Distance along Local Tangent at Sta. 151+68.36	Offset from Local Tangent at Sta. 151+68.36
A	2'-6"	35'-5 ⁵ / ₈ " Rt.
B	46'-7"	35'-1 ⁷ / ₈ " Rt.
C	44'-1 ⁷ / ₈ "	8" Rt.
D	43'-4 ⁵ / ₈ "	10'-3 ⁷ / ₈ " Lt.
E	39'-4 ¹ / ₂ "	10'-3 ¹ / ₂ " Lt.
F	36'-7 ⁷ / ₈ "	48'-10 ⁷ / ₈ " Lt.
G	-3'-5 ¹ / ₈ "	48'-7 ¹ / ₂ " Lt.
H	-8 ¹ / ₂ "	10'-0 ¹ / ₈ " Lt.
I	7 ¹ / ₈ "	11 ³ / ₄ " Rt.

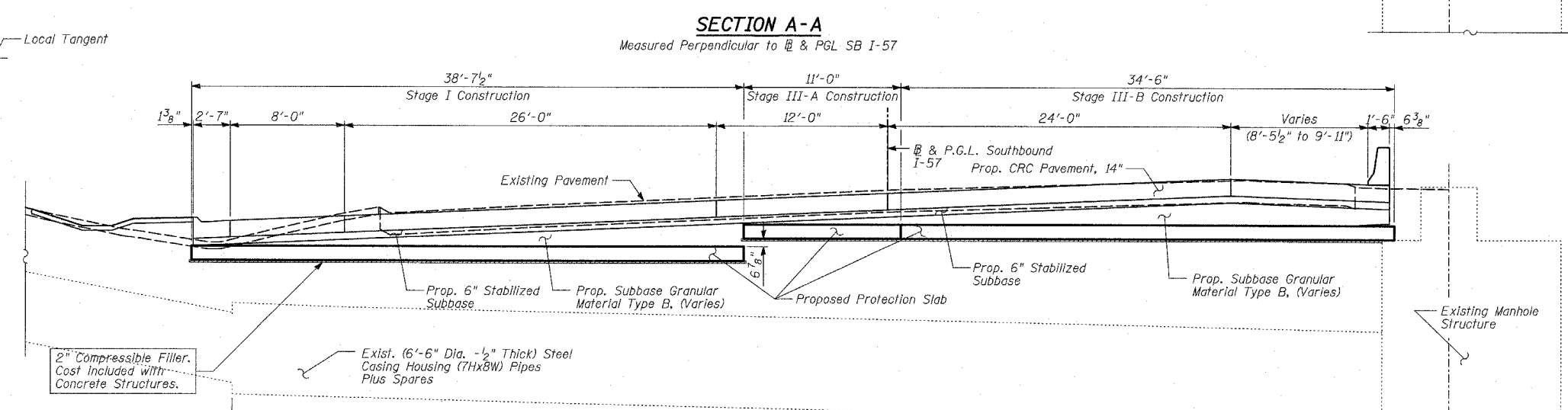
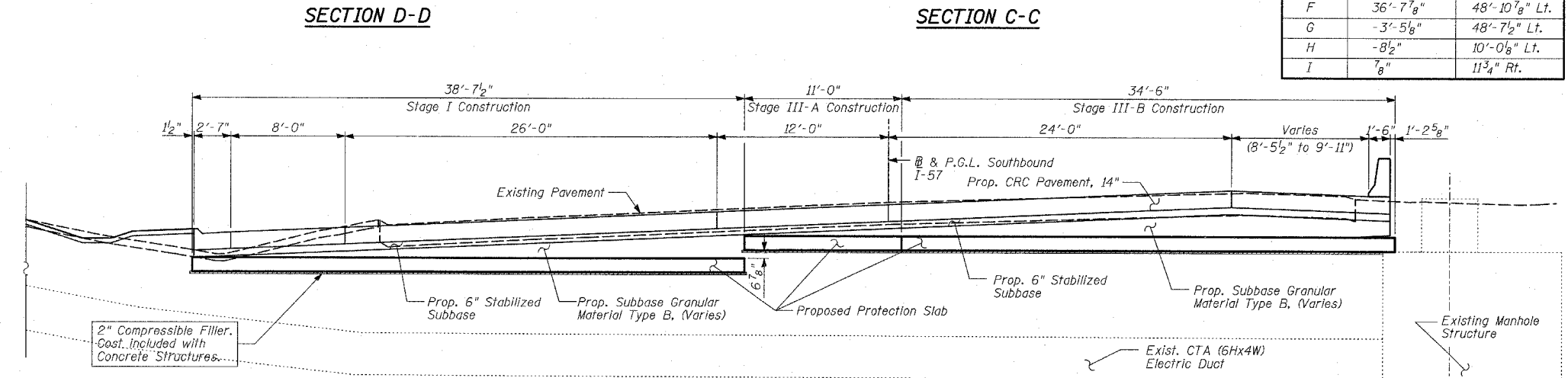
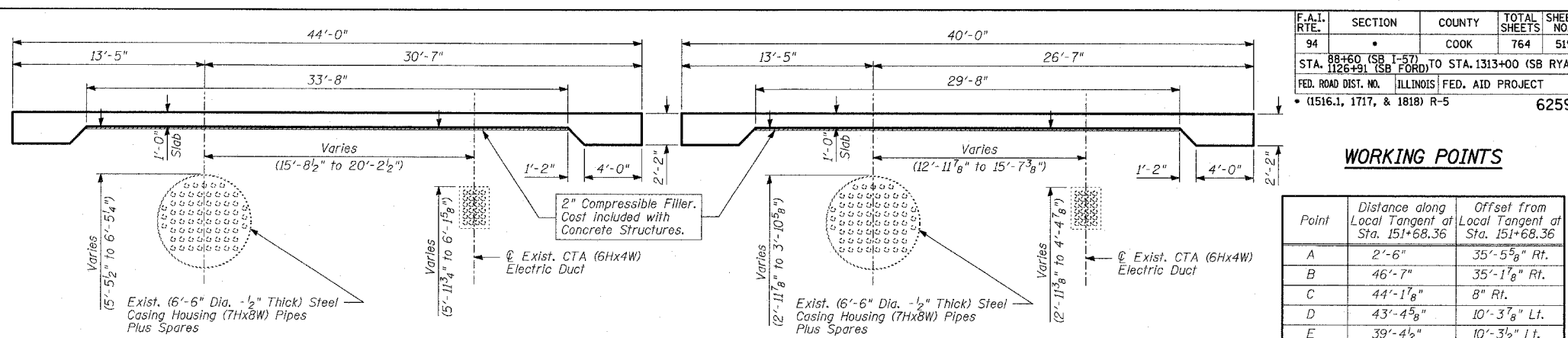
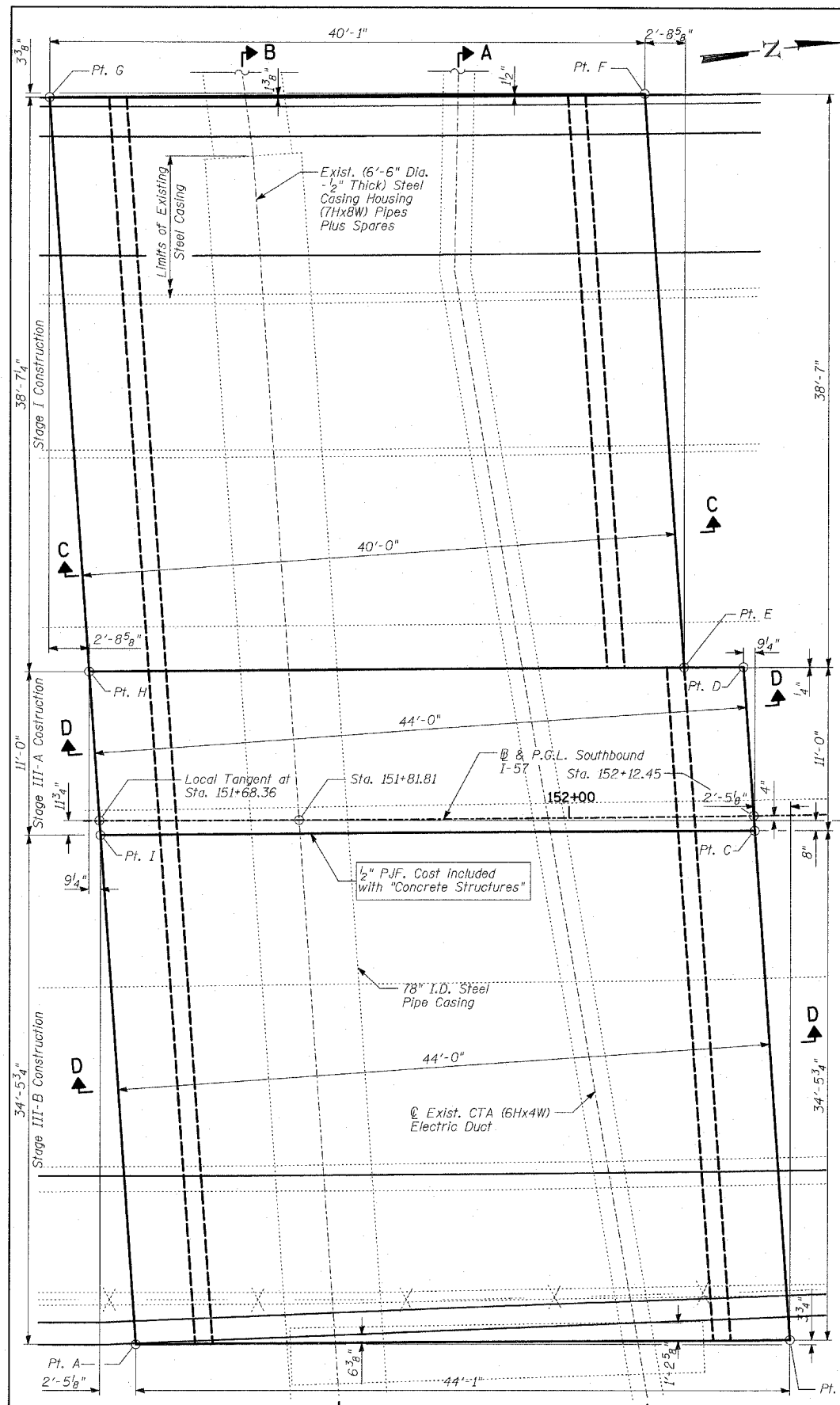

- NOTES:**
- Reinforcement bars shall conform to the requirements of AASHTO M31 or M322 Grade 60.
 - Plan dimensions and details relative to existing structure have been taken from existing plans and are subject to nominal construction variations. It shall be the Contractor's responsibility to verify such dimensions and details in the field and make necessary approved adjustments prior to construction or ordering of materials. Such variations shall not be cause for additional compensation for a change in the scope of the work; however, the Contractor will be paid for the quantity actually furnished at the unit price bid for the work.
 - All exposed concrete edges shall be chamfered 3/4" except as noted.
 - All elevations shown are based on the Chicago City Datum of 0.00, which is 579.19 feet above mean tide New York. (NAVD 88)
 - It is the Contractor's responsibility to locate existing utilities, especially the existing CTA Electric Duct & 78" Steel Pipe Casing. Any repairs due to damage of any utilities shall be the Contractor's responsibility.
 - The Contractor should take extreme caution for the safety and integrity of the CTA Electric Duct during the construction process.
 - Vacuum or hand digging should be used within 2'-0" of CTA Electric Duct.

SECTION B-B
Measured Perpendicular to @ & PGL SB I-57

TOTAL BILL OF MATERIAL

ITEM	UNIT	TOTAL
Structure Excavation	CU YD	412
Concrete Structures	CU YD	166
Reinforcement Bars, Epoxy Coated	POUND	36,870

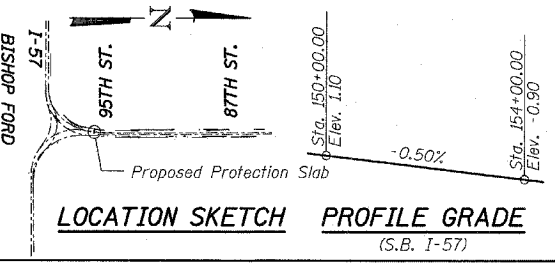

ILLINOIS DEPARTMENT OF TRANSPORTATION
 F.A.I. 94 (DAN RYAN EXPRESSWAY)
 PROTECTION SLAB FOR EXISTING
 CTA DUCTS
 STA. 151+81.81

Signed: Phillip D. Frey, S.E. Ill. Lic. No. 081-004826
 Expires 11-30-2006
 Date: 3/1/06

REVISIONS	
NAME	DATE

DESIGNED BY: MAF, DJR
 DRAWN BY: MAF, DJR
 CHECKED BY: MI

TYLIN INTERNATIONAL

DESIGN SPECIFICATION
 AASHTO 2002 Standard Specifications for Highway Bridges

DESIGN STRESSES
FIELD UNITS
 f'c = 3,500 psi
 ty = 60,000 psi (Reinforcement)

D:\02373\Structure\AC23\slabs\ms2\3dr\1093a_slab.dgn

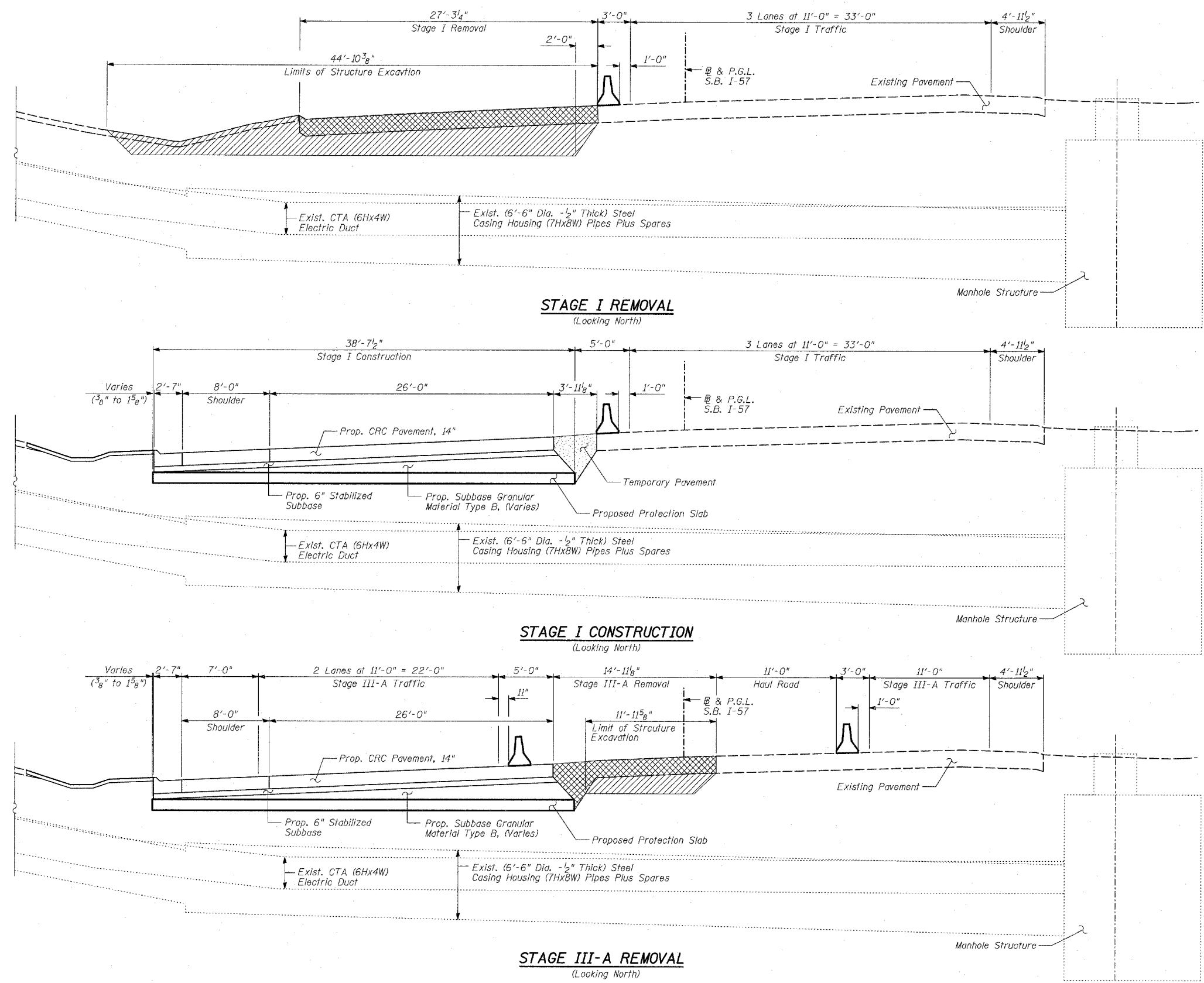

NOTES:
 1. All Measurements are Perpendicular to @ & PGL SB I-57.

LEGEND

	Pavement Removal
	Structure Excavation
	Temporary Pavement

REVISIONS	
NAME	DATE

ILLINOIS DEPARTMENT OF TRANSPORTATION
 F.A.I. 94 (DAN RYAN EXPRESSWAY)
 PROTECTION SLAB STAGE CONSTRUCTION FOR
 EXISTING CTA DUCTS
 (1 OF 2)
 STA. 151+81.81

S.N. DESIGNED BY: MAF, DJR
 SCALE: DRAWN BY: MAF, DJR
 DATE: MARCH 1, 2006 CHECKED BY: MI

F.A.I. RTE.	SECTION	COUNTY	TOTAL SHEETS	SHEET NO.
94	*	COOK	764	521
STA. 88+60 (SB I-57) TO STA. 1313+00 (SB RYAN)				
FED. ROAD DIST. NO. ILLINOIS FED. AID PROJECT				
* (1516.1, 1717, & 1818) R-5				

PLAN 237 STRUCTURE 23 STATION 1313+00 TO 1313+00

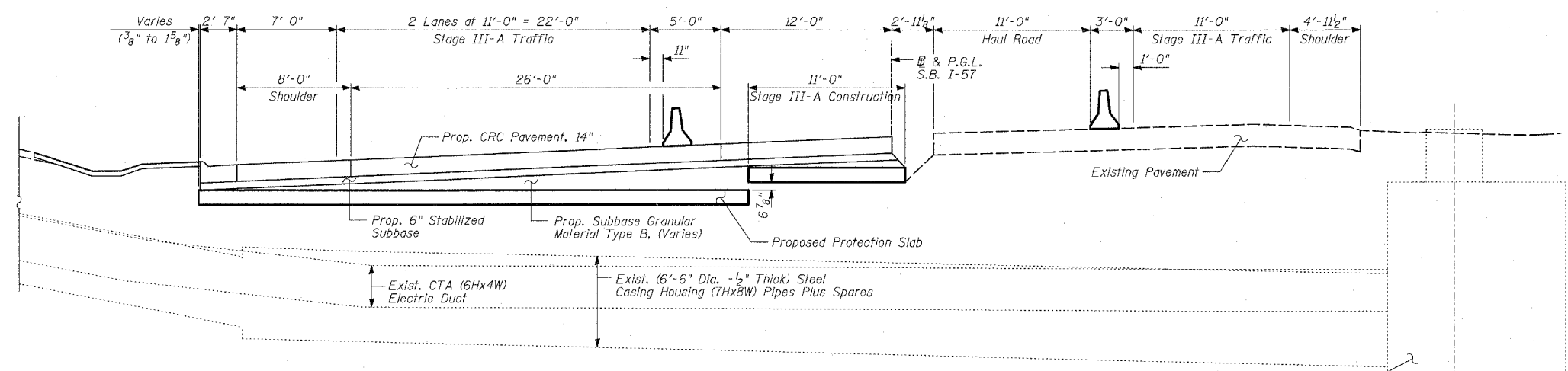

STAGE III-A CONSTRUCTION
(Looking North)

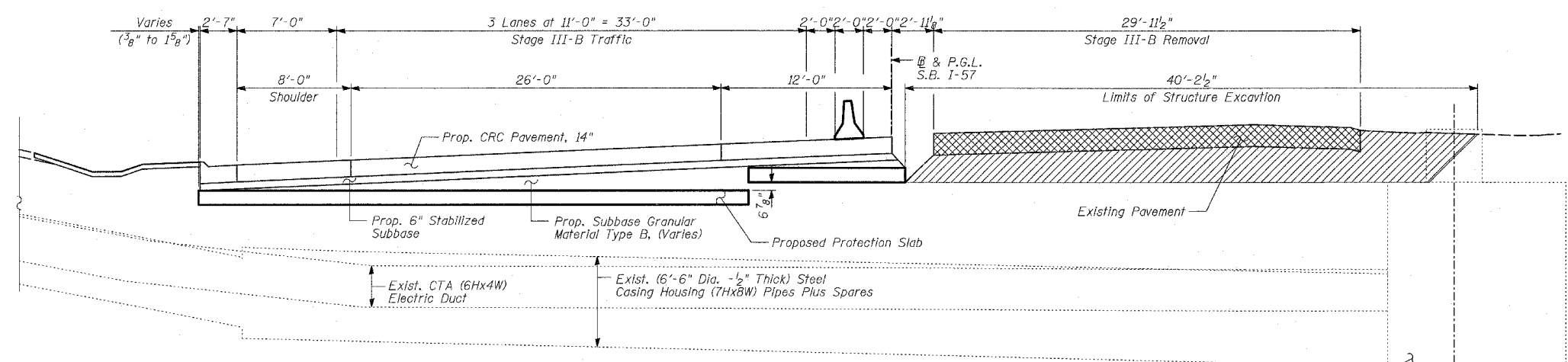

STAGE III-B REMOVAL
(Looking North)

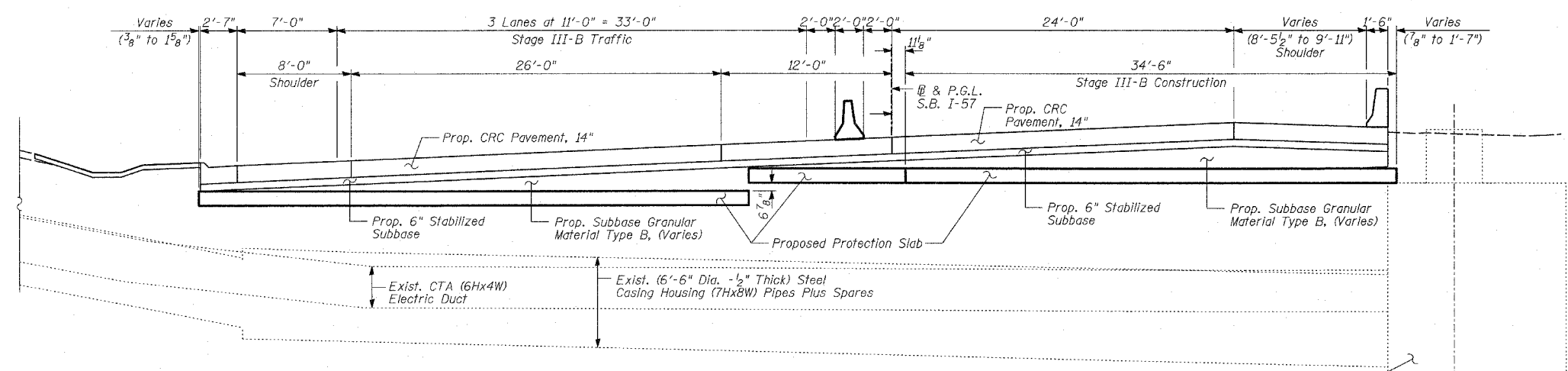

STAGE III-B CONSTRUCTION
(Looking North)

NOTES:
1. All Measurements are Perpendicular to @ & PGL SB I-57.

LEGEND

	Pavement Removal
	Structure Excavation

REVISIONS	
NAME	DATE

ILLINOIS DEPARTMENT OF TRANSPORTATION
F.A.I. 94 (DAN RYAN EXPRESSWAY)
PROTECTION SLAB STAGE CONSTRUCTION FOR
EXISTING CTA DUCTS
 (2 OF 2)
STA. 151+81.81

S.N. DESIGNED BY: MAF, DJR
 SCALE: DRAWN BY: MAF, DJR
 DATE: MARCH 1, 2006 CHECKED BY: MI

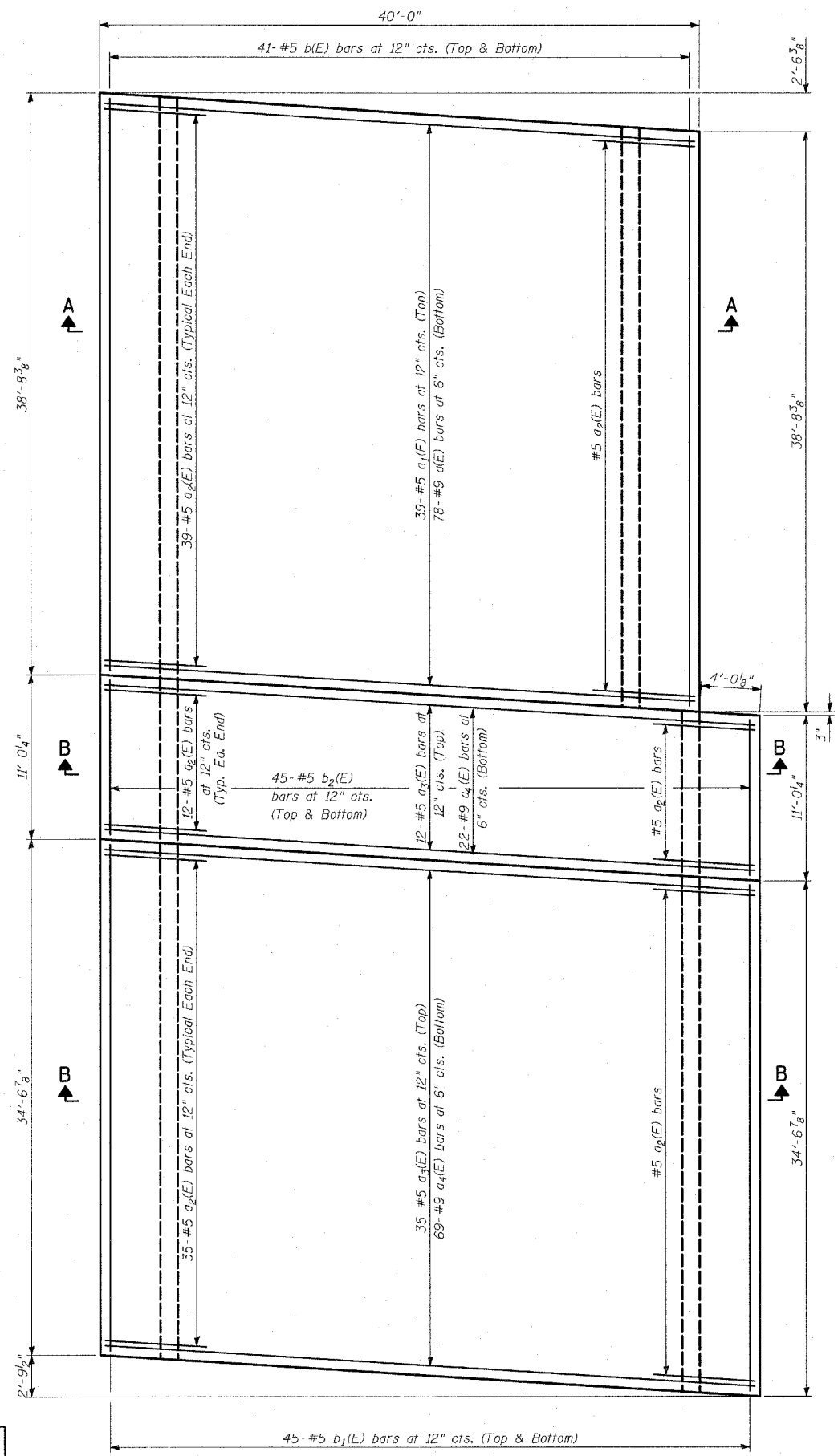

PLAN

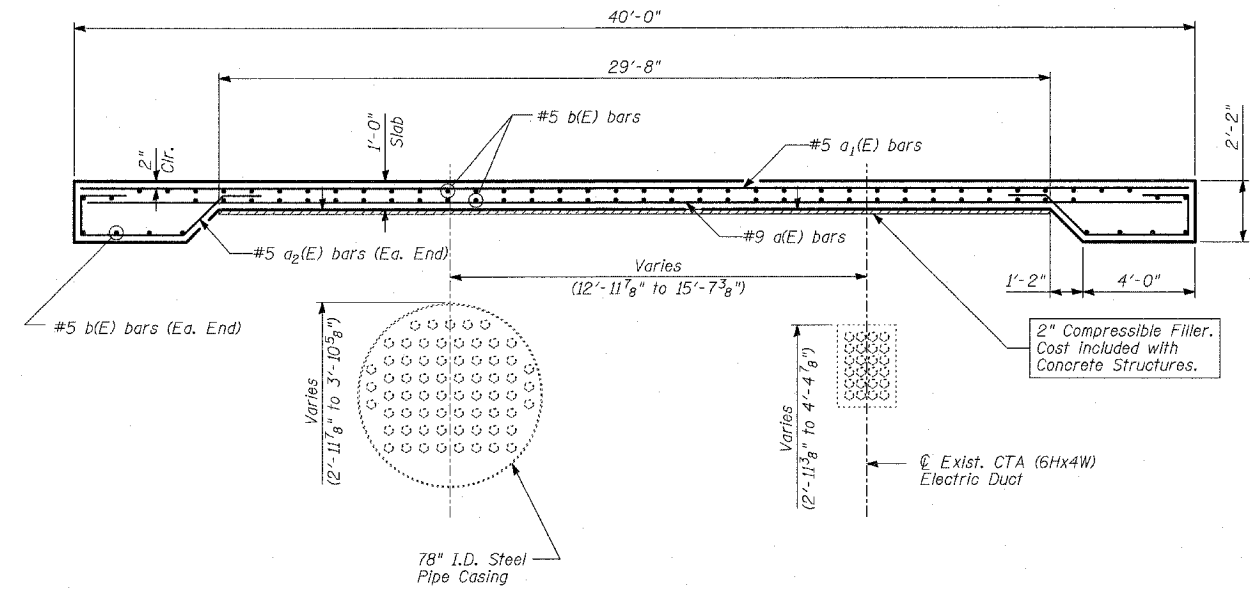

SECTION A-A

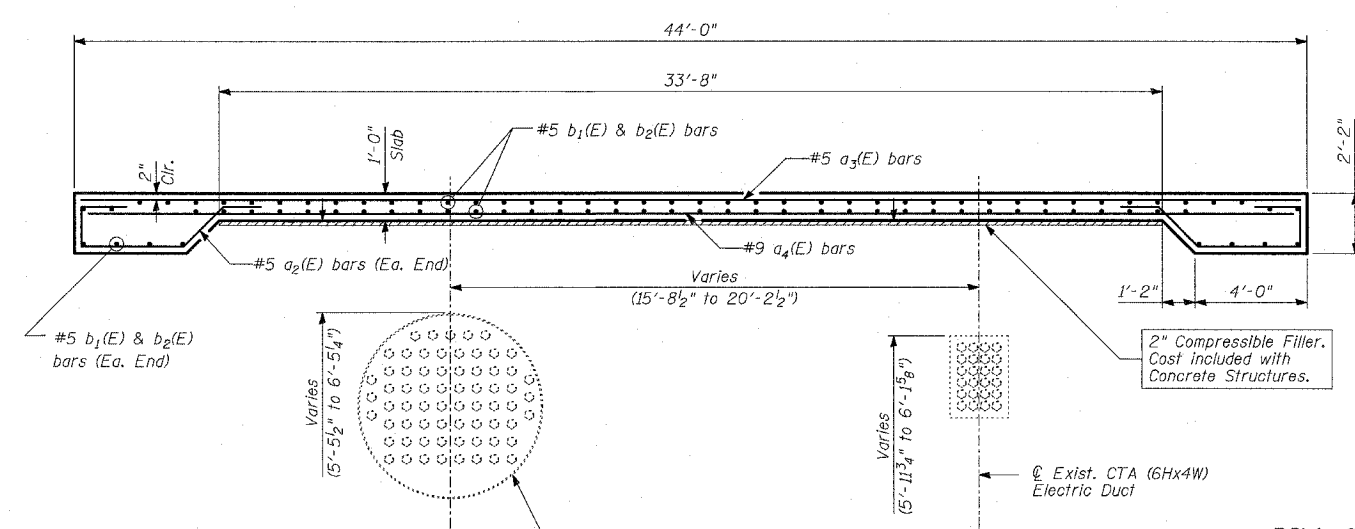

SECTION B-B

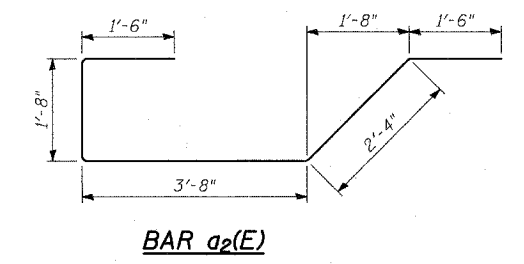

BAR a2(E)

BILL OF MATERIAL

Bar	No.	Size	Length	Shape
a(E)	78	#9	39'-1"	—
a1(E)	39	#5	39'-9"	—
a2(E)	172	#5	10'-8"	U
a3(E)	47	#5	43'-9"	—
a4(E)	91	#9	43'-1"	—
b(E)	82	#5	38'-4"	—
b1(E)	90	#5	34'-3"	—
b2(E)	90	#5	10'-8"	—
Reinforcement Bars, Epoxy Coated			POUND	36,870
Concrete Structures			CU YD	166

Reinforcement bars designated (E) shall be epoxy coated.

REVISIONS	
NAME	DATE

ILLINOIS DEPARTMENT OF TRANSPORTATION
**F.A.I. 94 (DAN RYAN EXPRESSWAY)
 PROTECTION SLAB DETAILS FOR EXISTING
 CTA DUCTS**

S.N. _____ DESIGNED BY: MAF, DJR
 SCALE: _____ DRAWN BY: MAF, DJR
 DATE: MARCH 1, 2006 CHECKED BY: MI

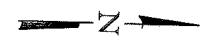
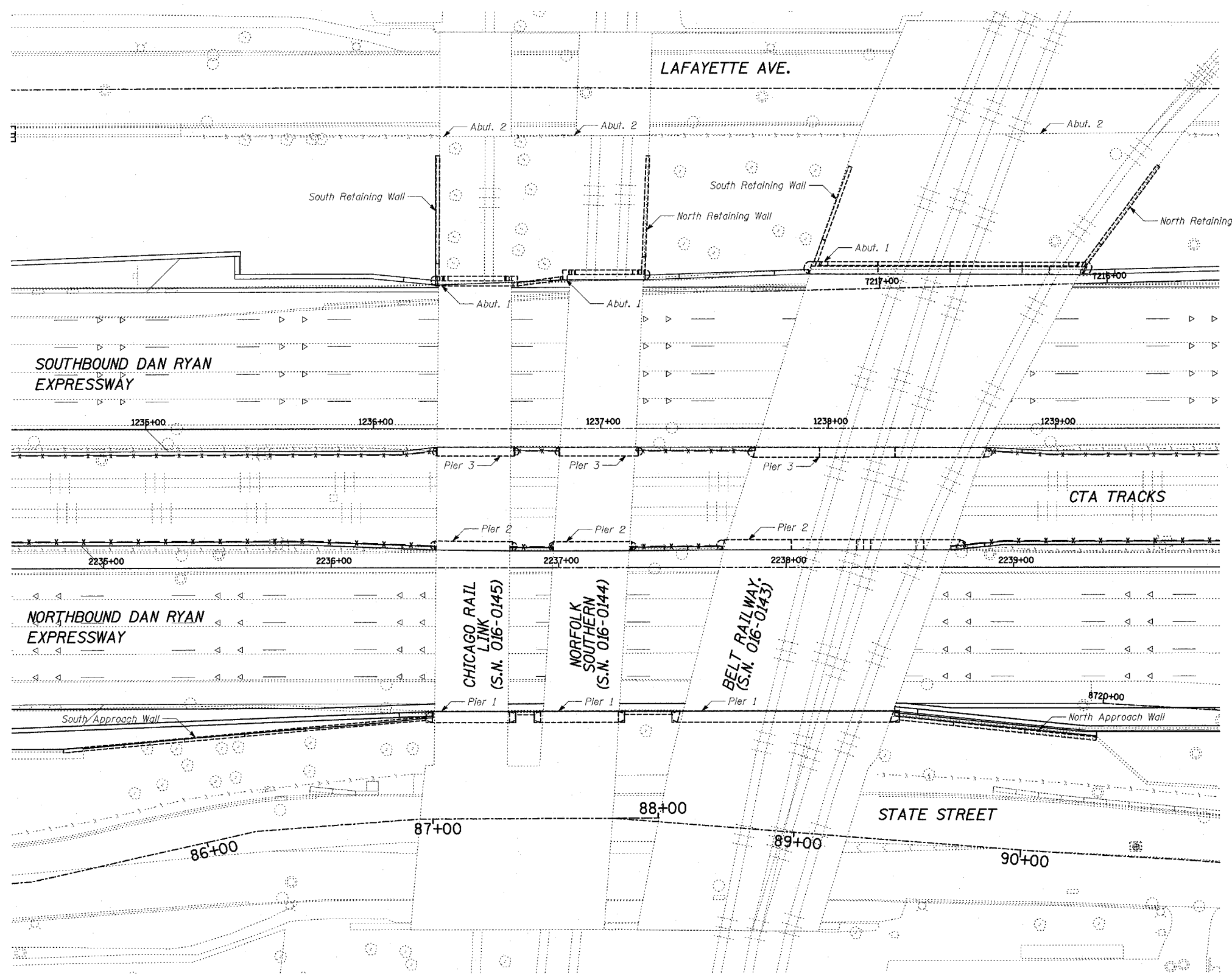

Place Top 3" of Concrete after removal of Formwork

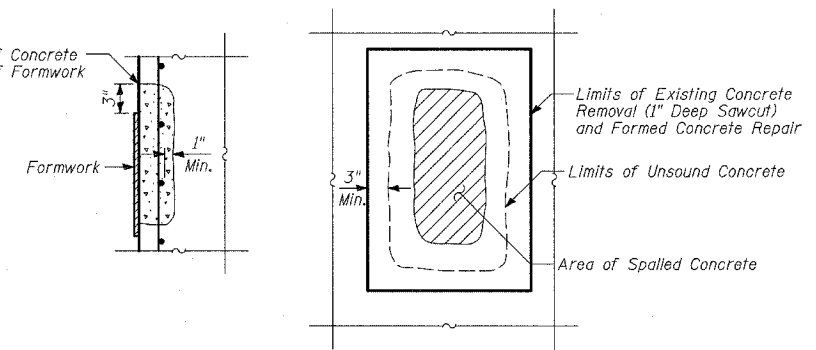

FORMED CONCRETE REPAIR

TOTAL BILL OF MATERIAL

ITEM	UNIT	016-0143	016-0144	016-0145
Epoxy Crack Sealing	FOOT	124	105	102
Formed Concrete Repair (Depth < 5")	SQ FT	1,192	255	122

PLAN

NOTES:

- Norfolk Southern is formerly known as C&W RR.
- Chicago Rail Link is formerly known as CRI&P RR.
- All work to be done by the Contractor on, over or in close proximity of the CTA (Chicago Transit Authority) right-of-way shall be performed in accordance with Article 107.12 of the Standard Specifications and additional CTA requirements (see Special Provisions)

TYLIN INTERNATIONAL

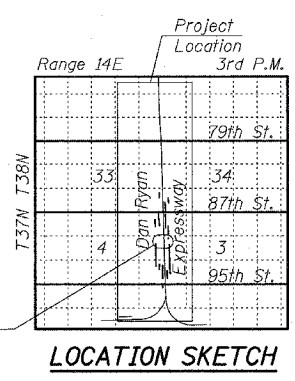

Signed *Phillip D. Frey*
 Phillip D. Frey, P.E., Ill. Lic. No. 081-004826
 Expires 11-30-2006.
 Date 3/1/06
 For drawings 1 thru 12 of 12

REVISIONS	
NAME	DATE



ILLINOIS DEPARTMENT OF TRANSPORTATION
**F.A.I. 94 (DAN RYAN EXPRESSWAY),
 SUBSTRUCTURE REPAIR FOR BELT RAILWAY,
 NORFOLK SOUTHERN & CHICAGO RAIL LINK
 GENERAL PLAN**

S.N. 016-0143, -0144 & -0145
 SCALE: N.T.S.
 DATE: MARCH 1, 2006

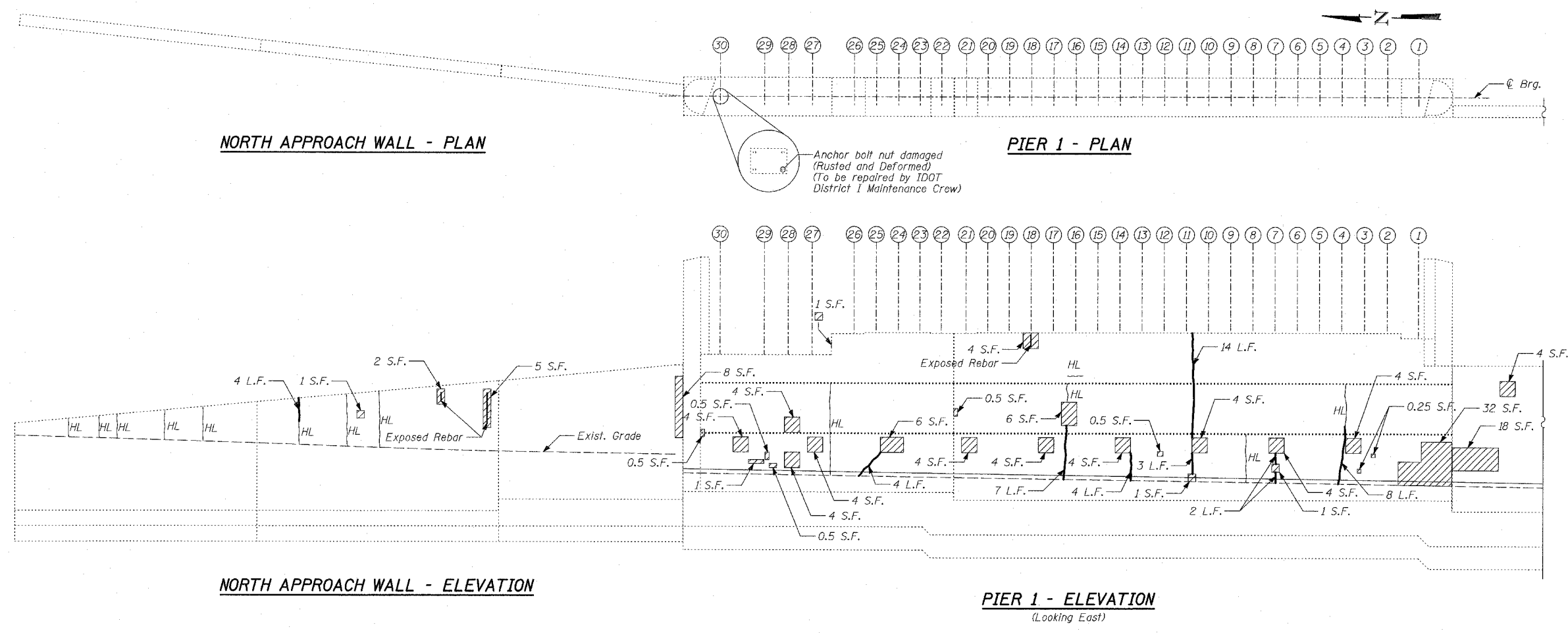
DESIGNED BY: DJR, MAF
 DRAWN BY: DJR, MAF
 CHECKED BY: MI



LEGEND

-  Formed Concrete Repair (Depth < 5")
-  Epoxy Crack Sealing
-  Hair Line Crack

BILL OF MATERIAL

ITEM	UNIT	TOTAL
Epoxy Crack Sealing	FOOT	48
Formed Concrete Repair (Depth < 5")	SQ FT	133

REVISIONS	
NAME	DATE

ILLINOIS DEPARTMENT OF TRANSPORTATION
 F.A.I. 94 (DAN RYAN EXPRESSWAY)
SUBSTRUCTURE REPAIR FOR BELT RAILWAY EXISTING PIER 1

S.N. 016-0143
 SCALE: N.T.S.
 DATE: MARCH 1, 2006

DESIGNED BY: MAF, DJR
 DRAWN BY: MAF, DJR
 CHECKED BY: MI



P:\02373\Structural\2373\allroad\msd\2373\01-04-06.dwg

02/24/2006 09:55:09 PM

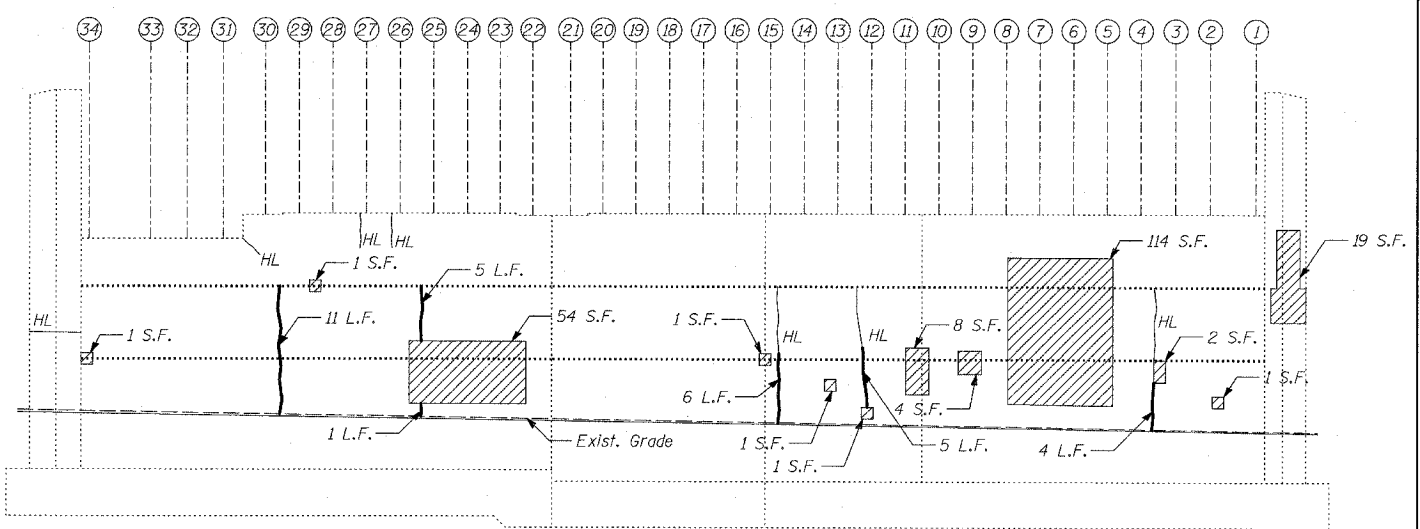
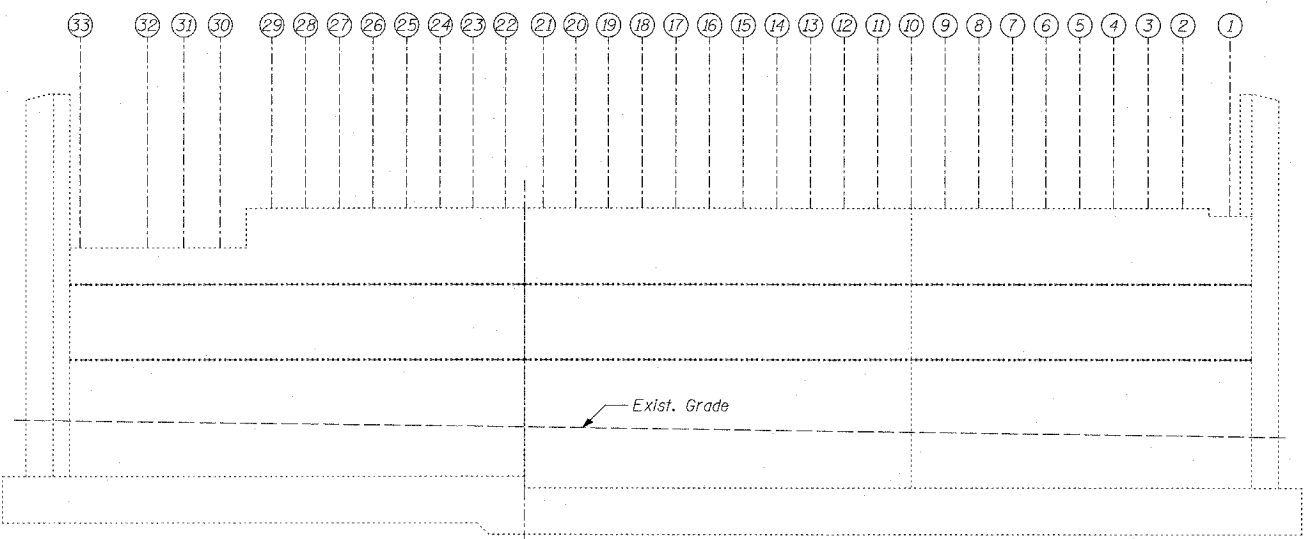
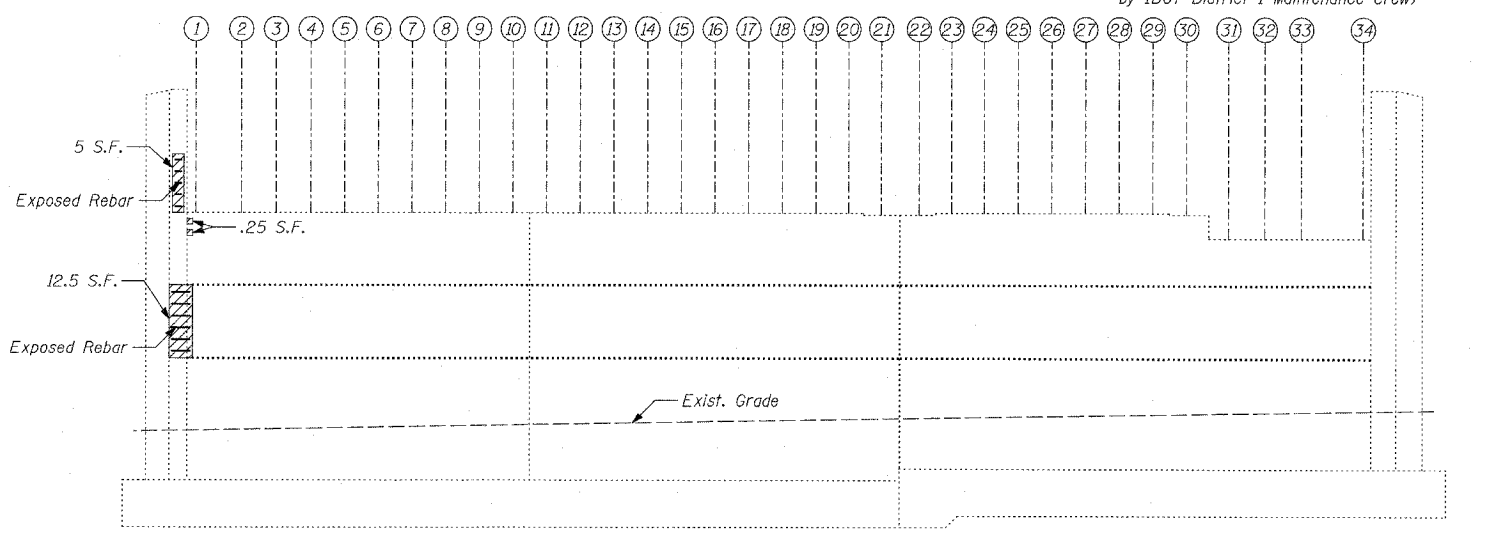
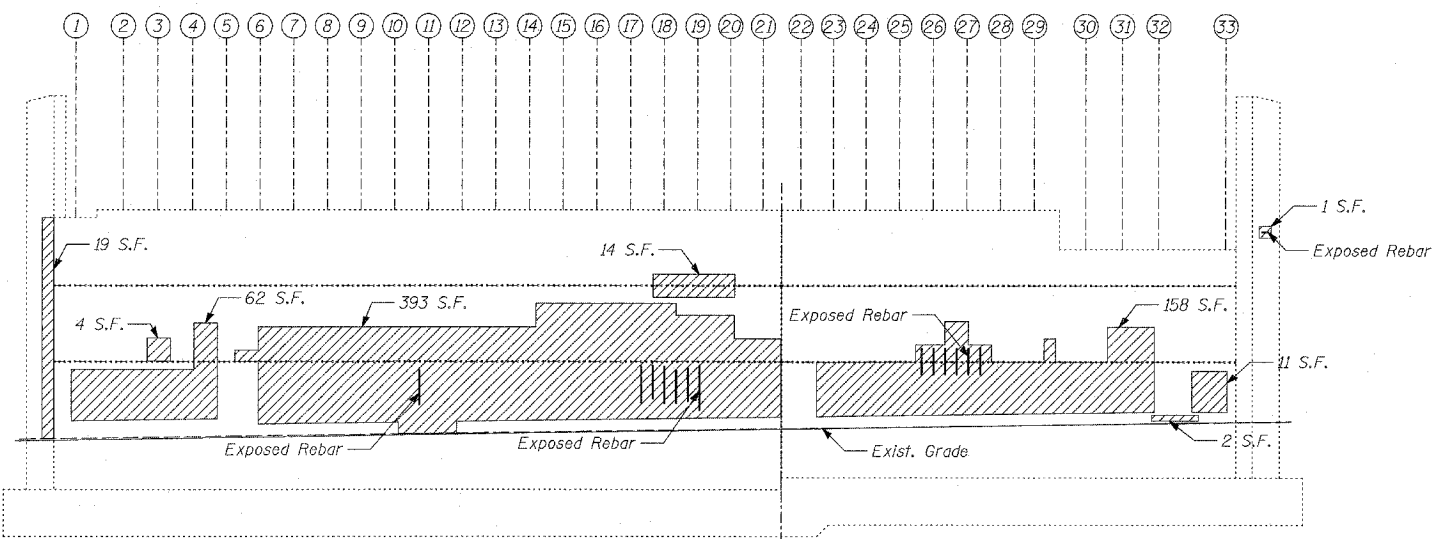
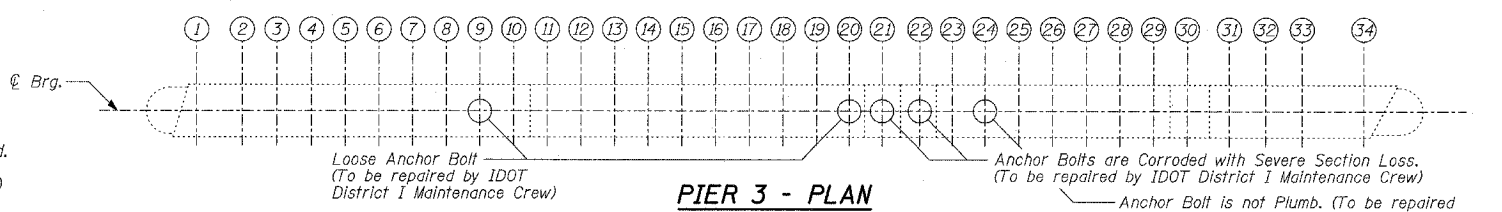
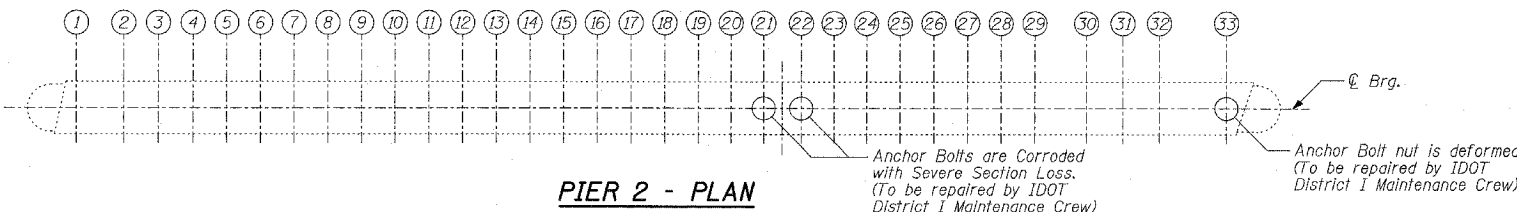
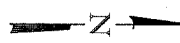

LEGEND

- Formed Concrete Repair (Depth < 5")
- Epoxy Crack Sealing
- Hair Line Crack

BILL OF MATERIAL

ITEM	UNIT	TOTAL
Epoxy Crack Sealing	FOOT	32
Formed Concrete Repair (Depth < 5")	SQ FT	889

TYLIN INTERNATIONAL

REVISIONS	
NAME	DATE

ILLINOIS DEPARTMENT OF TRANSPORTATION
F.A.I. 94 (DAN RYAN EXPRESSWAY)
SUBSTRUCTURE REPAIR FOR BELT RAILWAY EXISTING PIER 2 & PIER 3

S.N. 016-0143
 SCALE: N.T.S.
 DATE: MARCH 1, 2006

DESIGNED BY: MAF, DJR
 DRAWN BY: MAF, DJR
 CHECKED BY: MI

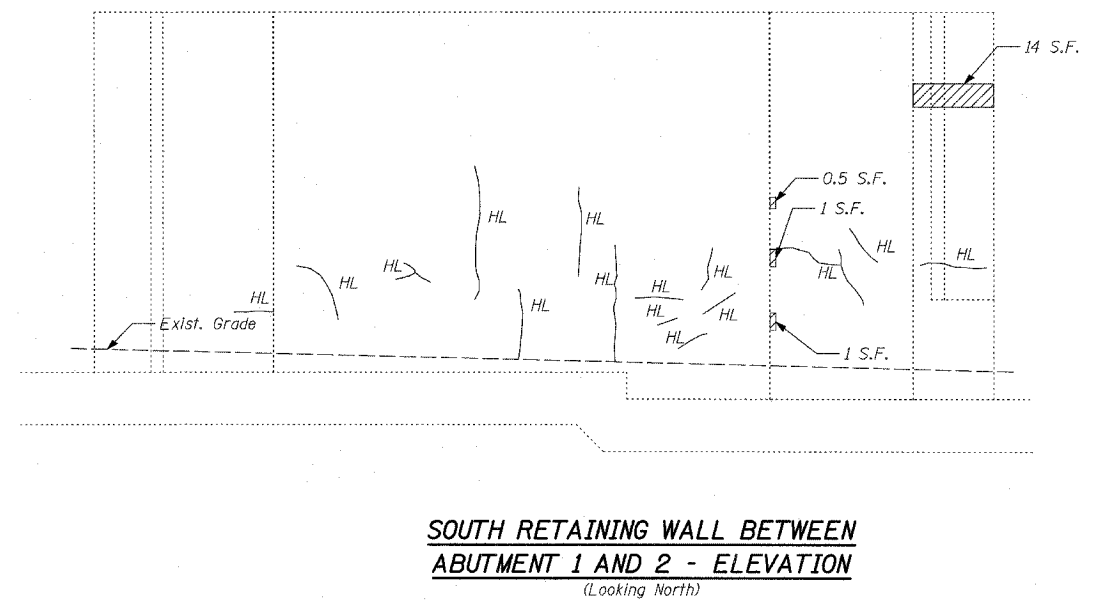
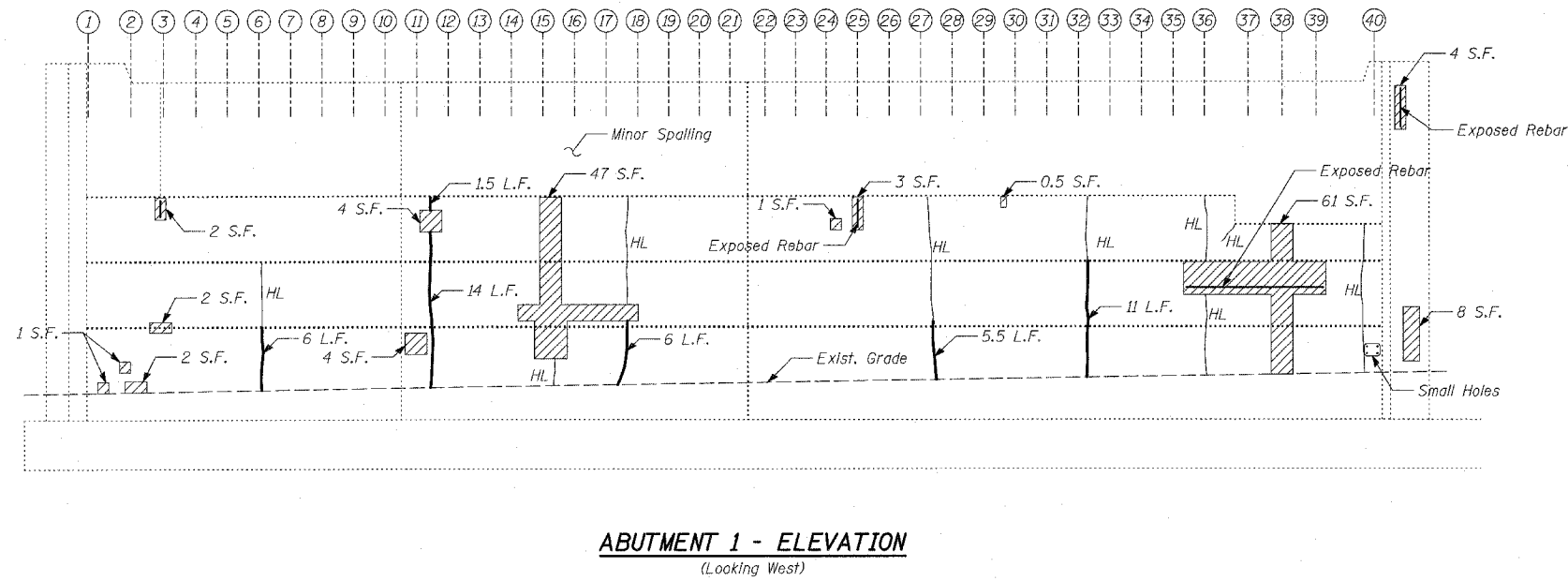
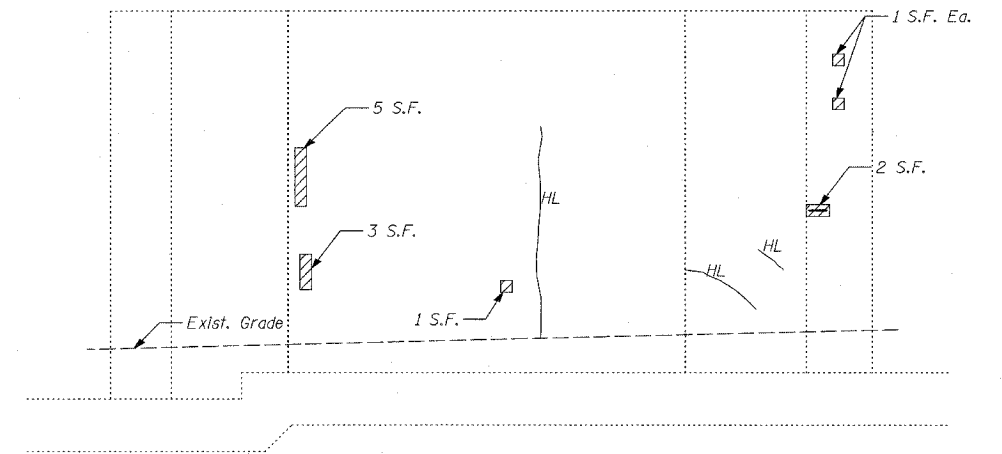
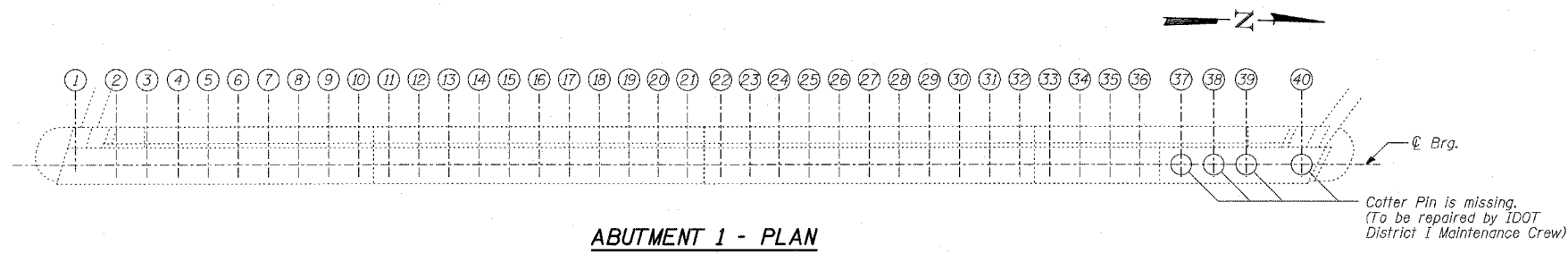

LEGEND

- Formed Concrete Repair (Depth < 5")
- Epoxy Crack Sealing
- Hair Line Crack

BILL OF MATERIAL

ITEM	UNIT	TOTAL
Epoxy Crack Sealing	FOOT	44
Formed Concrete Repair (Depth < 5")	SO FT	170

TYLIN INTERNATIONAL

REVISIONS	
NAME	DATE

ILLINOIS DEPARTMENT OF TRANSPORTATION
F.A.I. 94 (DAN RYAN EXPRESSWAY)
**SUBSTRUCTURE REPAIR FOR BELT RAILWAY
EXISTING ABUTMENT 1**

S.N. 016-0143
SCALE: N.T.S.
DATE: MARCH 1, 2006
DESIGNED BY: MAF, DJR
DRAWN BY: MAF, DJR
CHECKED BY: MI

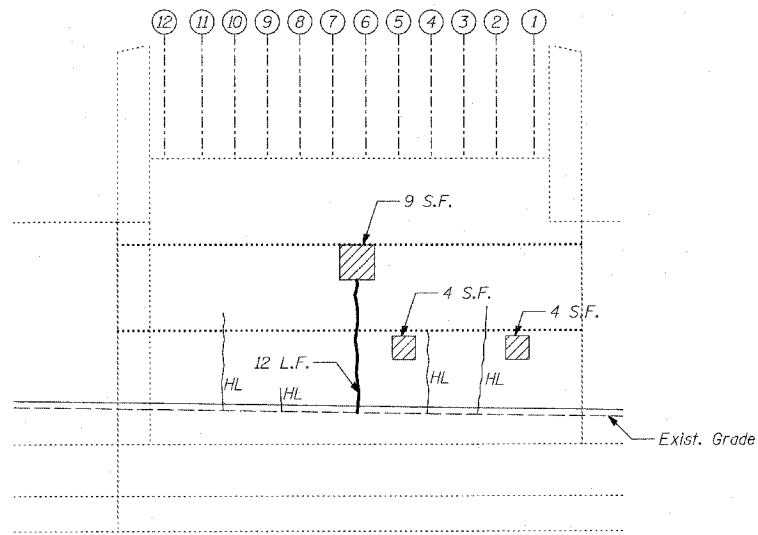

PIER 1 - ELEVATION
(Looking East)

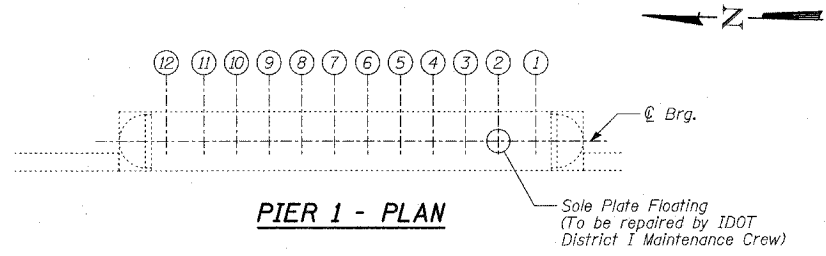

PIER 1 - PLAN

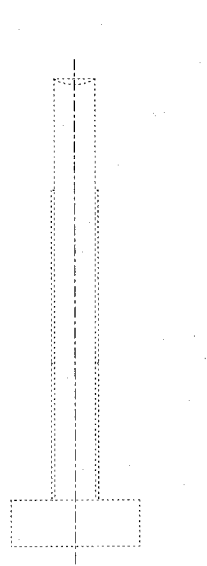

PIER 2 - END VIEW
(Looking North)

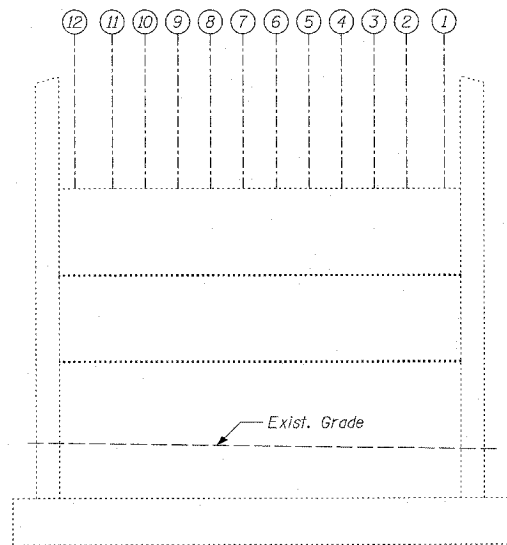

PIER 2 - ELEVATION
(Looking East)

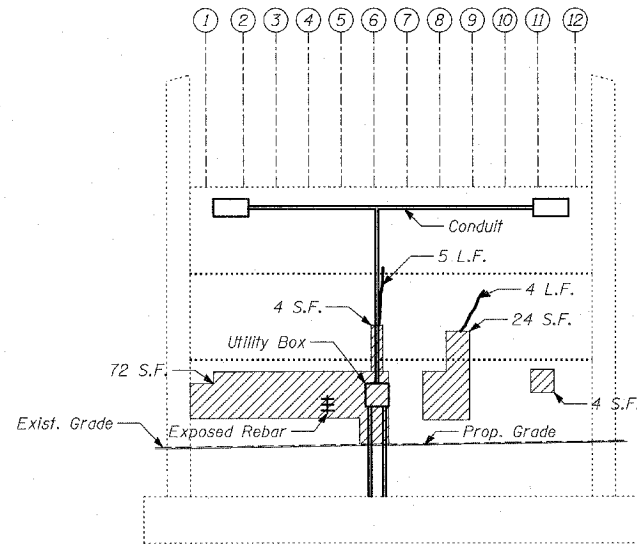

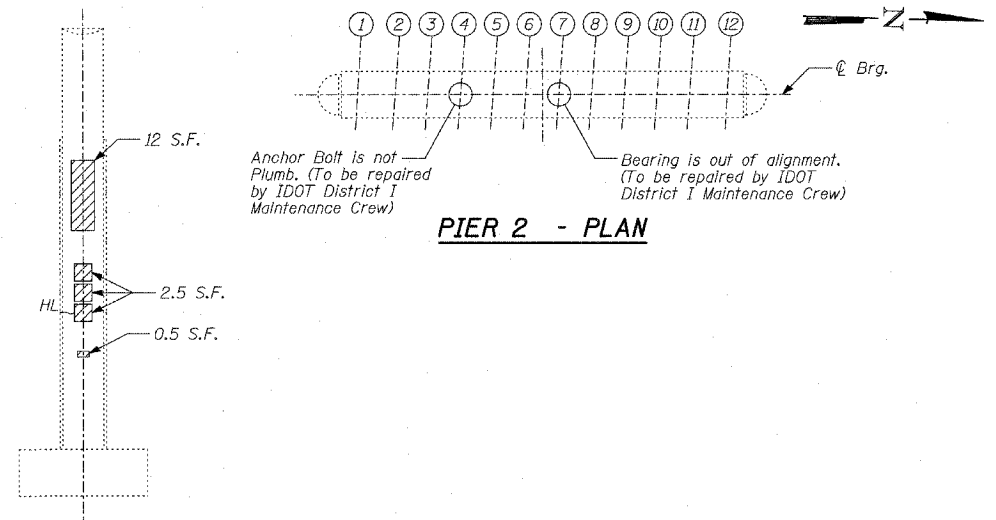

PIER 2 - ELEVATION
(Looking West)



PIER 2 - PLAN

PIER 2 - END VIEW
(Looking South)

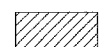
LEGEND

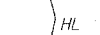
-  Formed Concrete Repair (Depth < 5")
-  Epoxy Crack Sealing
-  Hair Line Crack

BILL OF MATERIAL

ITEM	UNIT	TOTAL
Epoxy Crack Sealing	FOOT	21
Formed Concrete Repair (Depth < 5")	SQ FT	141

NOTES:

- The Contractor shall temporarily relocate the existing lighting fixtures (conduits, wiring and junction box) interfering with the formed concrete repairs and reinstall them after completing the formed concrete repairs.
- The Contractor shall inform the Engineer 5 days in advance of relocating fixtures in the areas of formed concrete repairs. The cost of temporarily relocating and reinstalling the lighting fixtures and any associated labor and equipment shall be included in the cost of "Formed Concrete Repairs."

TYLIN INTERNATIONAL

REVISIONS	
NAME	DATE

ILLINOIS DEPARTMENT OF TRANSPORTATION
F.A.I. 94 (DAN RYAN EXPRESSWAY)
SUBSTRUCTURE REPAIR
FOR NORFOLK SOUTHERN
EXISTING PIER 1 & PIER 2

S.N. 016-0144 DESIGNED BY: MAF, DJR
SCALE: N.T.S. DRAWN BY: MAF, DJR
DATE: MARCH 1, 2006 CHECKED BY: MI

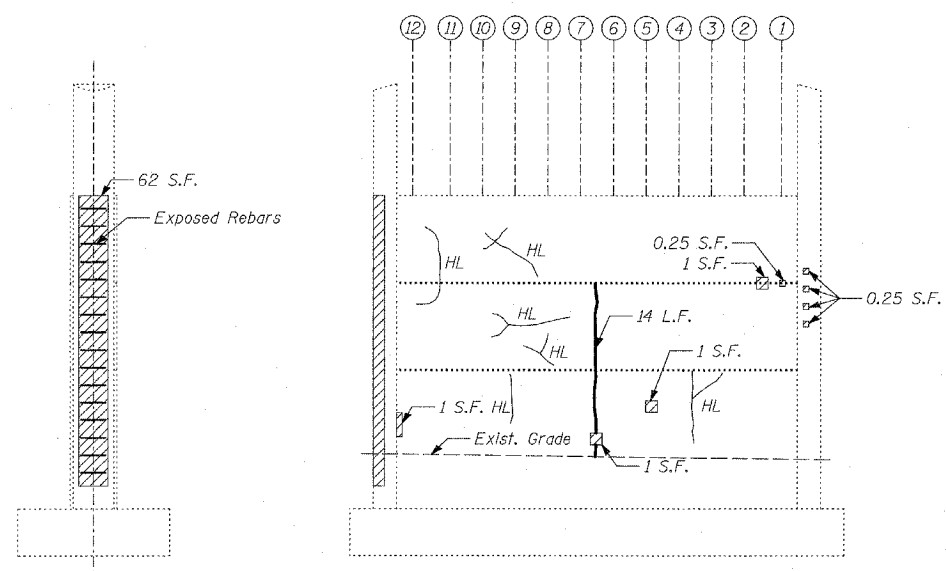

PIER 3 - END VIEW
(Looking North)

PIER 3 - ELEVATION
(Looking East)

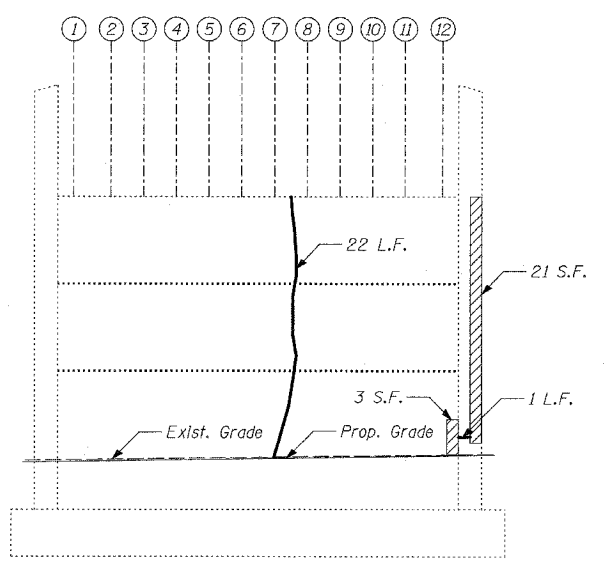

PIER 3 - ELEVATION
(Looking West)

PIER 3 - END VIEW
(Looking South)

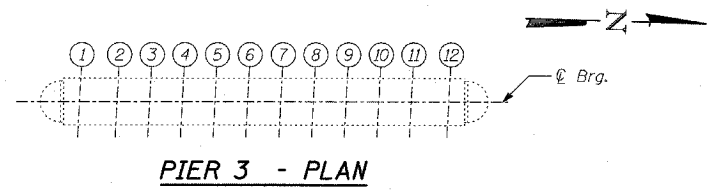

PIER 3 - PLAN

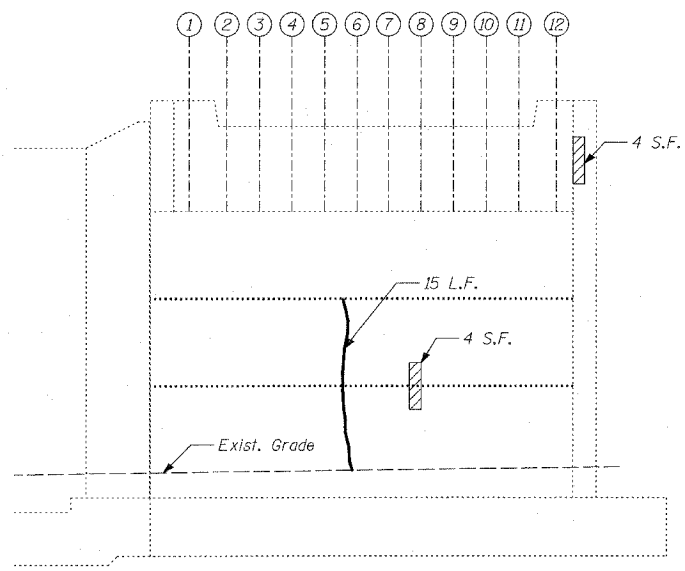

ABUTMENT 1 - ELEVATION
(Looking West)

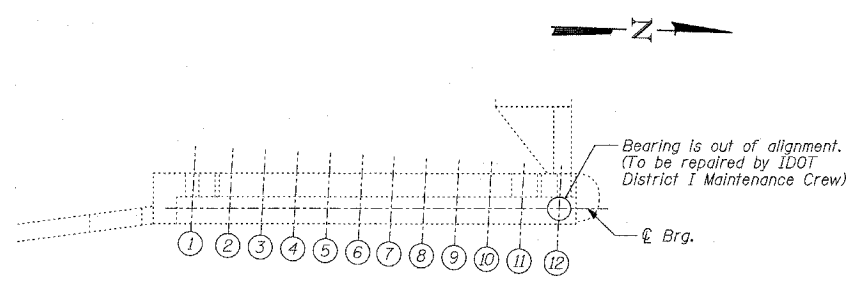

ABUTMENT 1 - PLAN

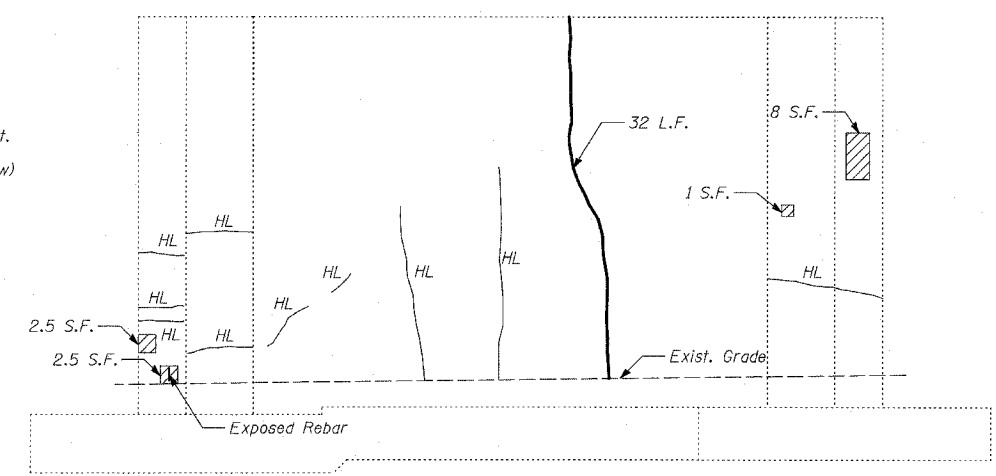

NORTH RETAINING WALL BETWEEN ABUTMENT 1 AND 2 - ELEVATION
(Looking South)

LEGEND

- Formed Concrete Repair (Depth < 5")
- Epoxy Crack Sealing
- Hair Line Crack

BILL OF MATERIAL

ITEM	UNIT	TOTAL
Epoxy Crack Sealing	FOOT	84
Formed Concrete Repair (Depth < 5")	SQ FT	113

TYLIN INTERNATIONAL

REVISIONS	
NAME	DATE

ILLINOIS DEPARTMENT OF TRANSPORTATION
F.A.I. 94 (DAN RYAN EXPRESSWAY)
SUBSTRUCTURE REPAIR
FOR NORFOLK SOUTHERN
EXISTING PIER 3 & ABUTMENT 1

S.N. 016-0144 DESIGNED BY: MAF, DJR
SCALE: N.T.S. DRAWN BY: MAF, DJR
DATE: MARCH 1, 2006 CHECKED BY: MI

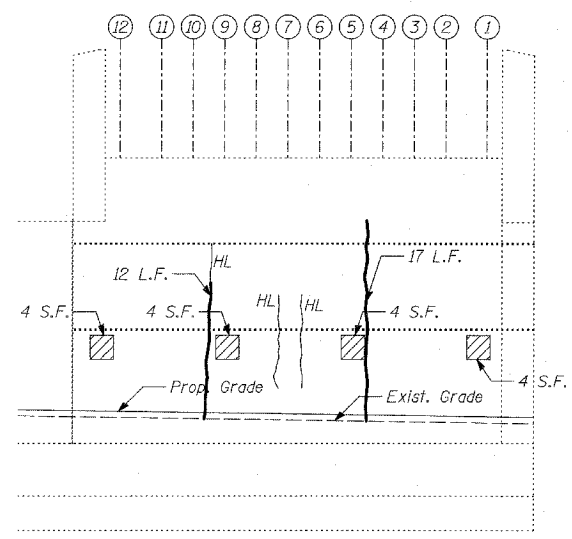
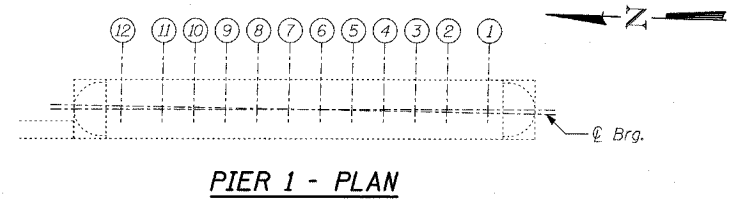

PIER 1 - ELEVATION
(Looking East)

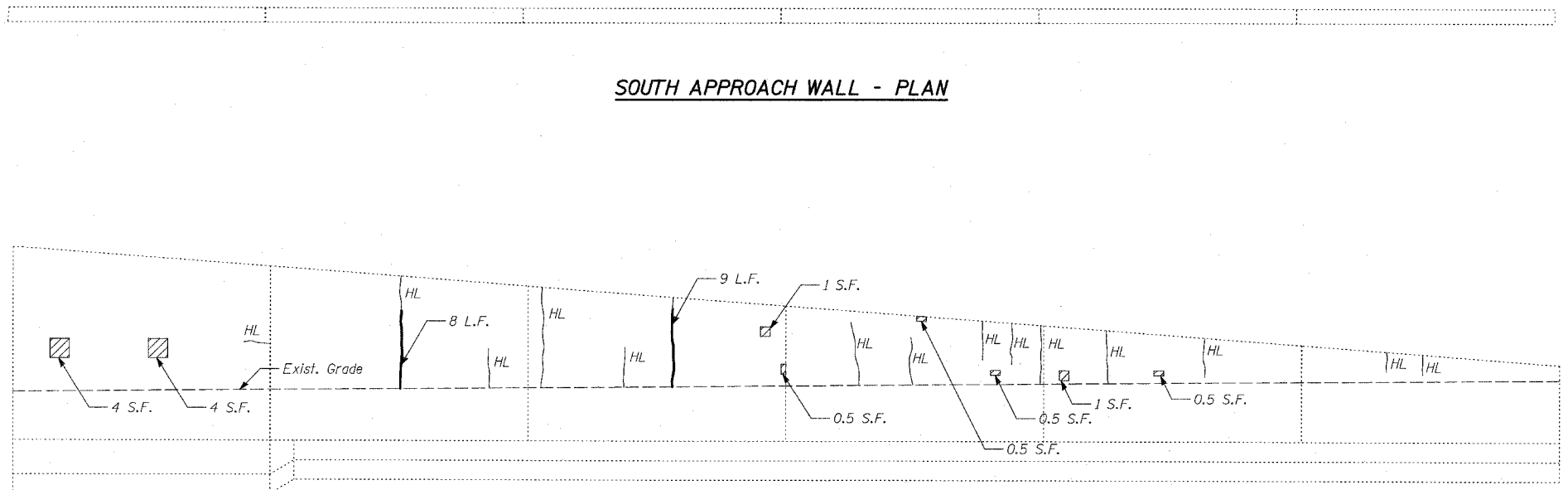

SOUTH APPROACH WALL - ELEVATION
(Looking East)

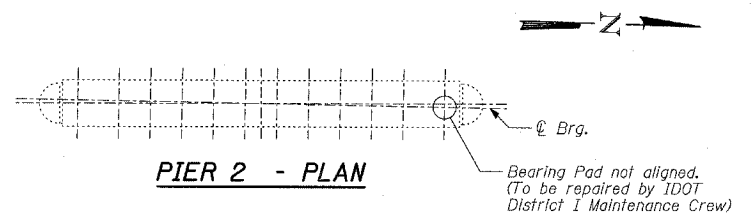
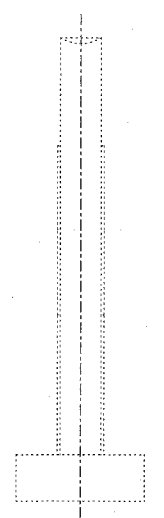
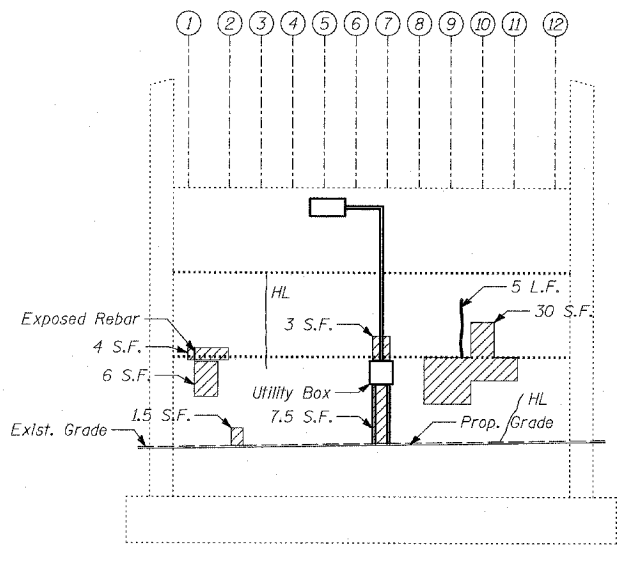
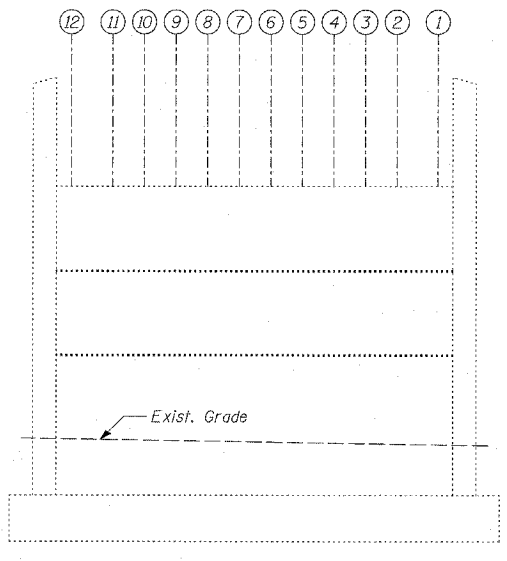
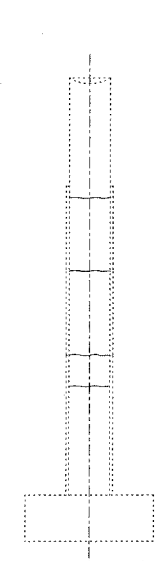

PIER 2 - END VIEW
(Looking North)

PIER 2 - ELEVATION
(Looking East)

PIER 2 - ELEVATION
(Looking West)

PIER 2 - END VIEW
(Looking South)

LEGEND

- Formed Concrete Repair (Depth < 5")
- Epoxy Crack Sealing
- Hair Line Crack

BILL OF MATERIAL

ITEM	UNIT	TOTAL
Epoxy Crack Sealing	FOOT	51
Formed Concrete Repair (Depth < 5")	SQ FT	80

NOTES:

- The Contractor shall temporarily relocate the existing lighting fixtures (conduits, wiring and junction box) interfering with the formed concrete repairs and reinstall them after completing the formed concrete repairs.
- The Contractor shall inform the Engineer 5 days in advance of relocating fixtures in the areas of formed concrete repairs. The cost of temporarily relocating and reinstalling the lighting fixtures and any associated labor and equipment shall be included in the cost of "Formed Concrete Repairs."

REVISIONS	
NAME	DATE

ILLINOIS DEPARTMENT OF TRANSPORTATION
F.A.I. 94 (DAN RYAN EXPRESSWAY)
SUBSTRUCTURE REPAIR
FOR CHICAGO RAIL LINK
EXISTING PIER 1 & PIER 2

S.N. 016-0145 DESIGNED BY: MAF, DJR
SCALE: N.T.S. DRAWN BY: MAF, DJR
DATE: MARCH 1, 2006 CHECKED BY: MI

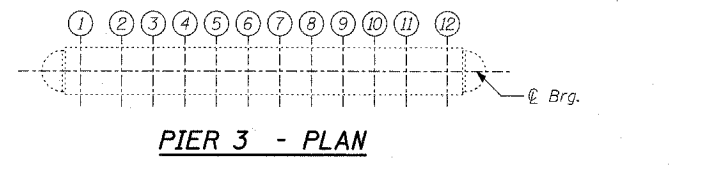
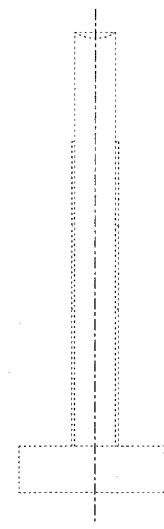
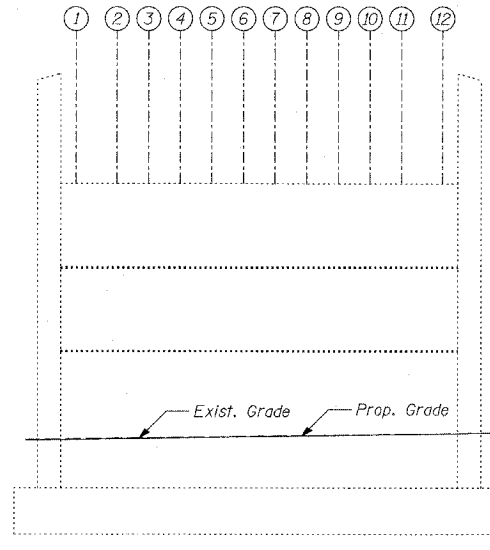
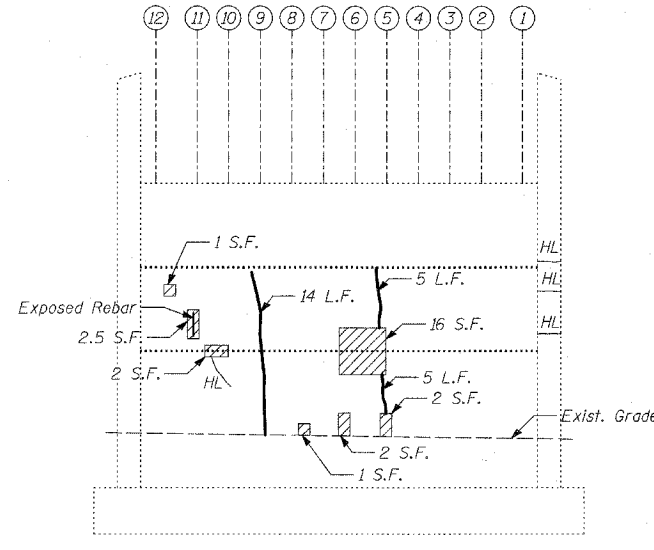
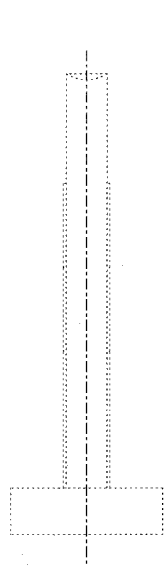

PIER 3 - END VIEW
(Looking North)

PIER 3 - ELEVATION
(Looking East)

PIER 3 - ELEVATION
(Looking West)

PIER 3 - END VIEW
(Looking South)

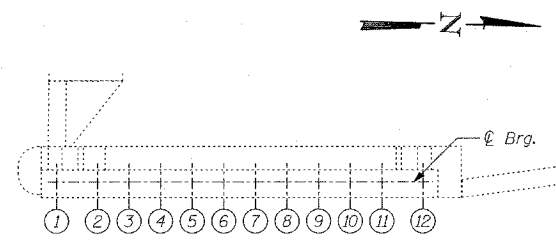
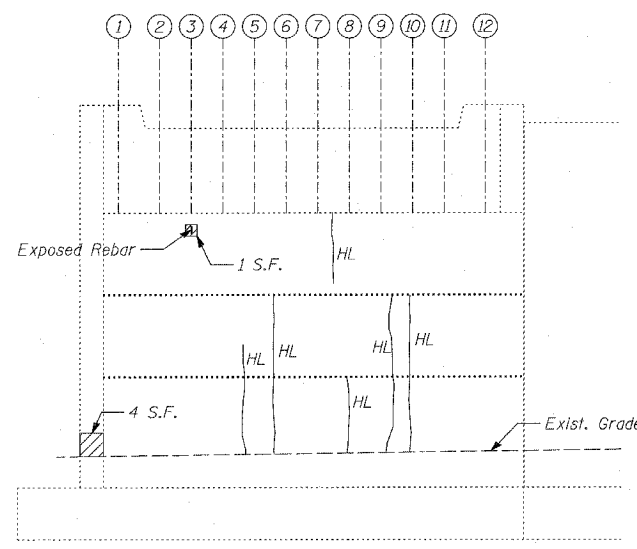

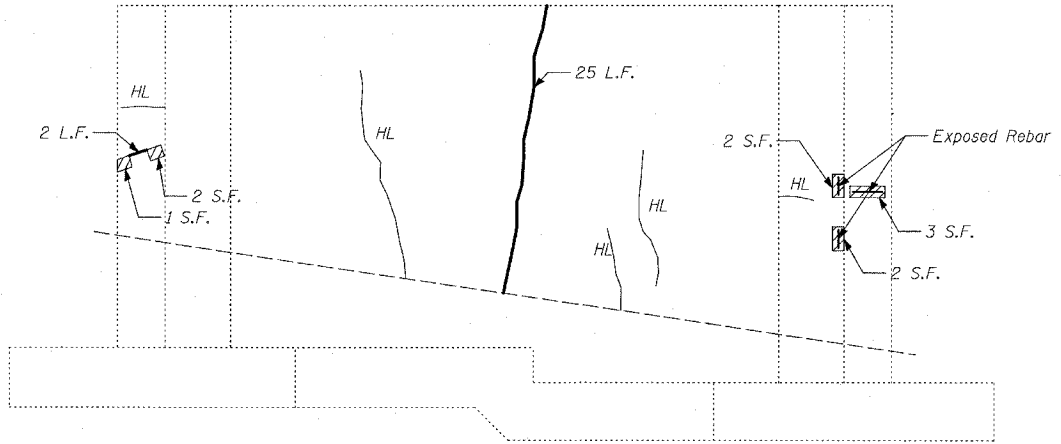

ABUTMENT 1 - ELEVATION
(Looking West)

ABUTMENT 1 - PLAN

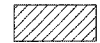

SOUTH RETAINING WALL BETWEEN ABUTMENT 1 AND 2 - ELEVATION
(Looking North)

LEGEND

-  Formed Concrete Repair (Depth < 5")
-  Epoxy Crack Sealing
-  Hair Line Crack

BILL OF MATERIAL

ITEM	UNIT	TOTAL
Epoxy Crack Sealing	FOOT	51
Formed Concrete Repair (Depth < 5")	SQ FT	42

TYLIN INTERNATIONAL

REVISIONS	
NAME	DATE

ILLINOIS DEPARTMENT OF TRANSPORTATION
 F.A.I. 94 (DAN RYAN EXPRESSWAY)
 SUBSTRUCTURE REPAIR
 FOR CHICAGO RAIL LINK
 EXISTING PIER 3 & ABUTMENT 1

S.N. 016-0145
 SCALE: N.T.S.
 DATE: MARCH 1, 2006

DESIGNED BY: MAF, DJR
 DRAWN BY: MAF, DJR
 CHECKED BY: MI

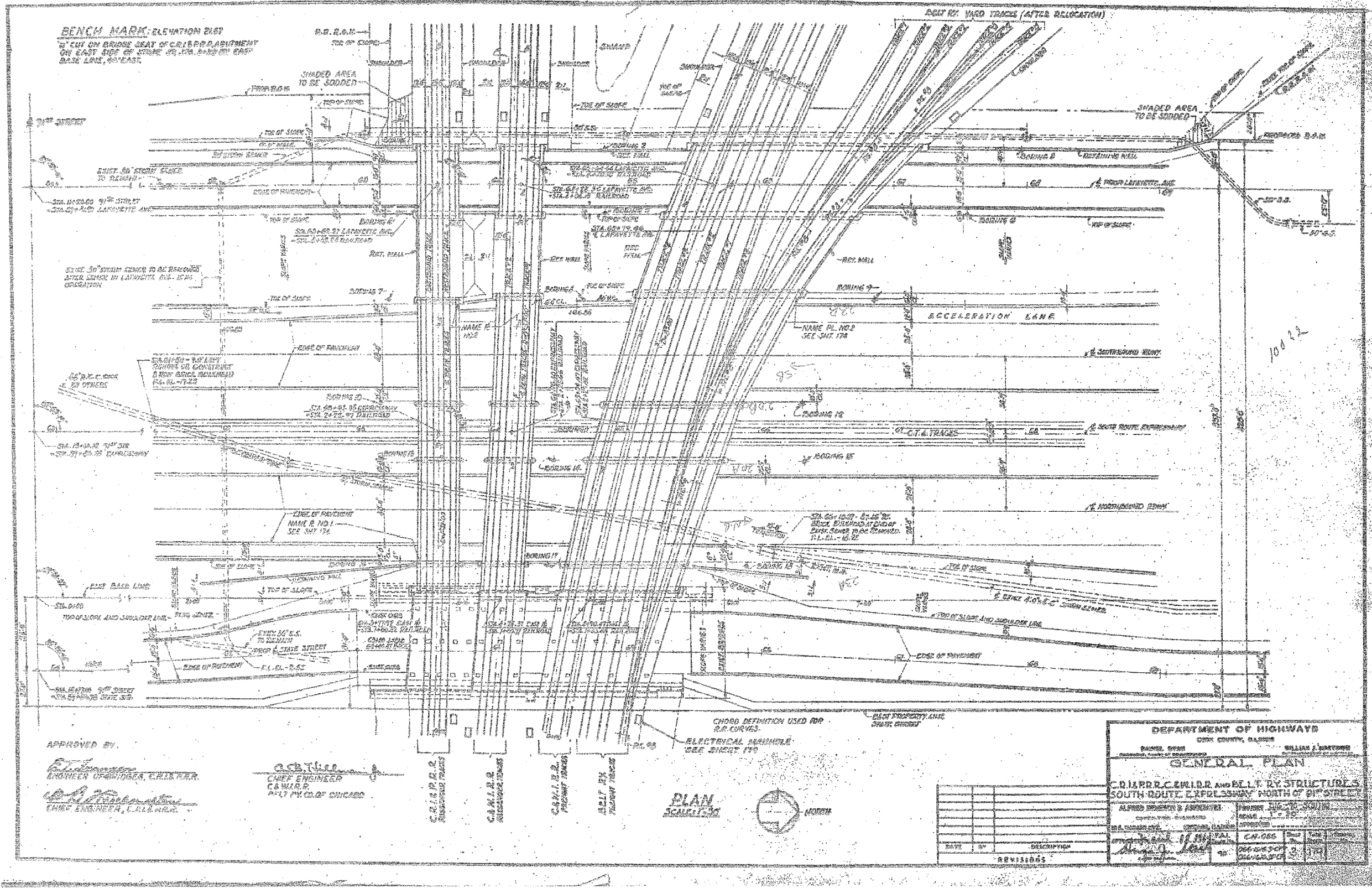

APPROVED BY:
[Signature]
 ENGINEER OF BRIDGES, C.I.R.R.R.
[Signature]
 CHIEF ENGINEER, C.I.R.R.R.

[Signature]
 CHIEF ENGINEER
 C & N. R. R.
 1417 PH. CO. OF CHICAGO

PLAN
 SCALE: 1" = 40'



DEPARTMENT OF HIGHWAYS
 COOK COUNTY, ILLINOIS

GENERAL PLAN
 C.I.R.R.R. WIDE AND BELL RY STRUCTURES
 SOUTH ROUTE EXPRESSWAY NORTH OF 9TH STREET

ALPHONSE J. BARTON
 CHIEF ENGINEER

DATE: 11/11/05

DATE	BY	DESCRIPTION

REVISIONS	
NAME	DATE

ILLINOIS DEPARTMENT OF TRANSPORTATION
 F.A.I. 94 (DAN RYAN EXPRESSWAY)
 EXISTING GENERAL PLAN AND ELEVATION
 FOR BELT RAILWAY, NORFOLK SOUTHERN
 & CHICAGO RAIL LINK

S.N. 016-0143, -0144 & -0145
 SCALE: N.T.S.
 DATE: MARCH 1, 2006

DESIGNED BY:
 DRAWN BY: MAF, DJR
 CHECKED BY: MI

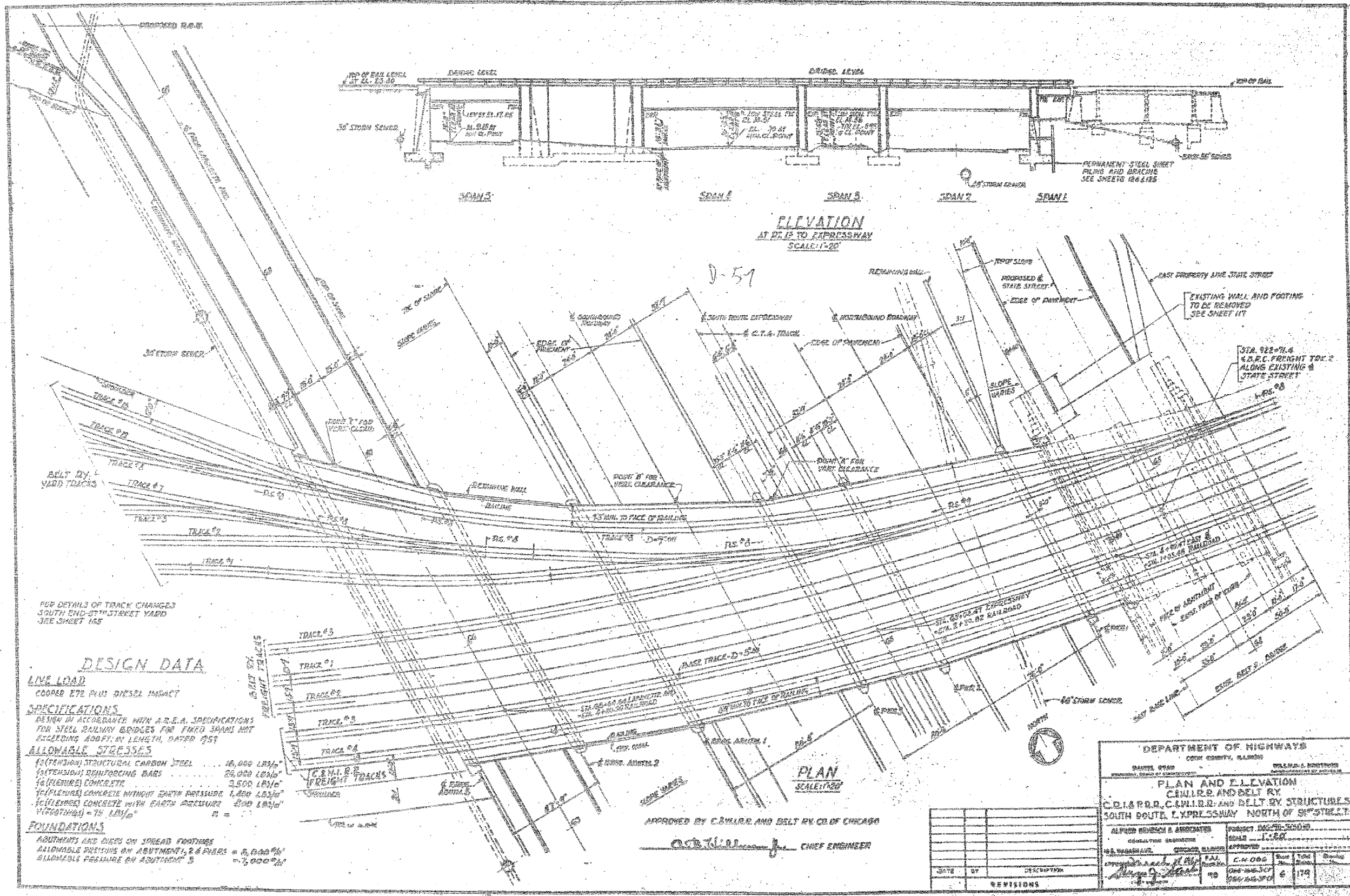

ELEVATION
AT RT. 15 TO EXPRESSWAY
SCALE: 1"=20'

PLAN
SCALE: 1"=80'

DESIGN DATA

LIVE LOAD
COOPER E72 PLUS DIESEL IMPACT

SPECIFICATIONS
DESIGN IN ACCORDANCE WITH A.S.T.M. SPECIFICATIONS FOR STEEL RAILWAY BRIDGES FOR FREQ. SPANS NOT EXCEEDING 400 FT. IN LENGTH, DATED 1957

ALLOWABLE STRESSES

(TENSION) STRUCTURAL CARBON STEEL	16,000 LB/SQ IN.
(TENSION) REINFORCING BARS	20,000 LB/SQ IN.
(FLEXURE) CONCRETE	2,500 LB/SQ IN.
(FLEXURE) CONCRETE WITHOUT EXCESSIVE CRACKING	1,800 LB/SQ IN.
(FLEXURE) CONCRETE WITH EXCESSIVE CRACKING	1,000 LB/SQ IN.
(FOOTINGS) - 75 LB/SQ IN.	

FOUNDATIONS
ABUTMENTS AND PILES ON SPREAD FOOTINGS
ALLOWABLE PRESSURE ON ABUTMENT 1, 2 & PILES = 8,000 PSF
ALLOWABLE PRESSURE ON ABUTMENT 5 = 7,000 PSF

APPROVED BY C. SWAN AND BELT RY. CO. OF CHICAGO
 CHIEF ENGINEER

DEPARTMENT OF HIGHWAYS
COOK COUNTY, ILLINOIS

PLAN AND ELEVATION
CRUIERS AND BELT RY
C.B.I.A. P.R.C. & N.I.R.R. AND BELT RY STRUCTURES
SOUTH ROUTE EXPRESSWAY NORTH OF 51ST STREET

ALFRED BEVEN & ASSOCIATES
CONSULTING ENGINEERS

PROJECT NO. 12-2000
SCALE: 1"=80'

DATE	BY	DESCRIPTION

REVISIONS

REVISIONS	NAME	DATE

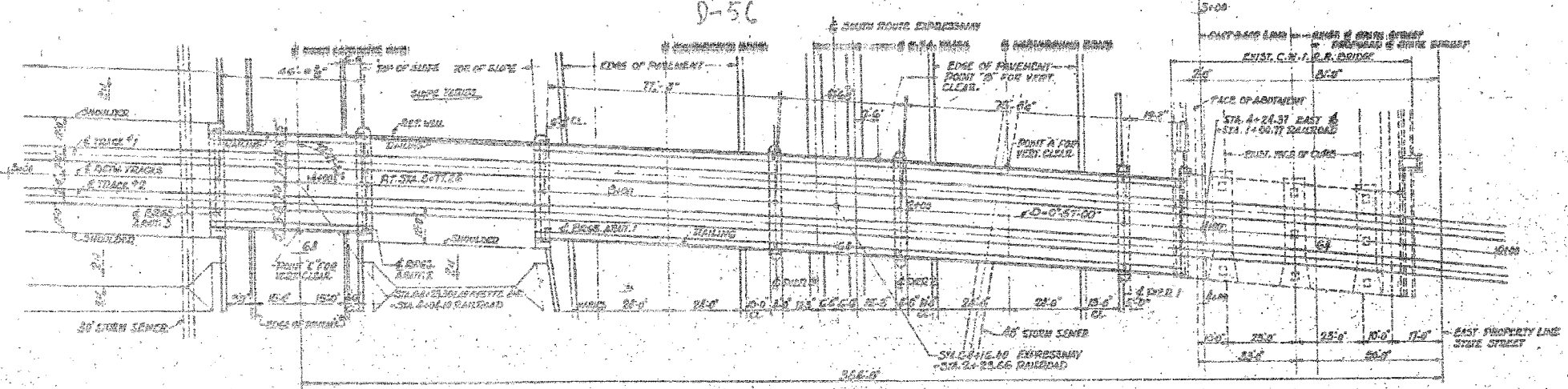
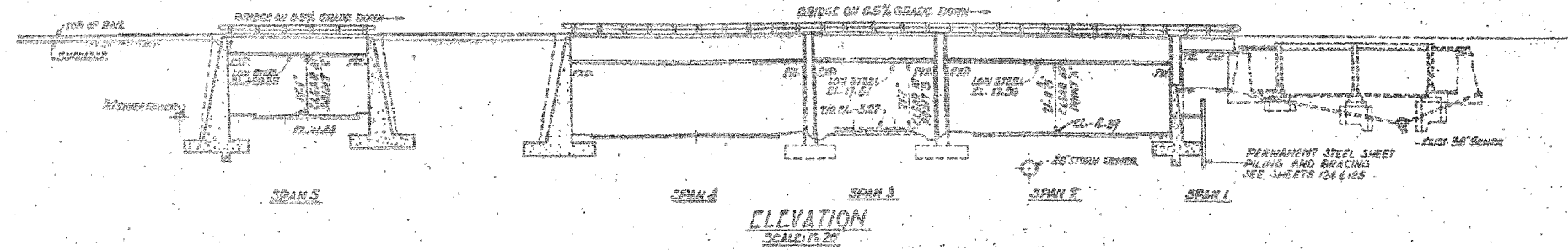

PLAN SCALE: 1/8\"/>

DESIGN DATA

LIVE LOAD
 COOPER E-72 PLUS DIESEL IMPACT

SPECIFICATIONS
 DESIGN IN ACCORDANCE WITH A.R.E.A. SPECIFICATIONS FOR STEEL RAILWAY BRIDGES FOR RYKED SPANS NOT EXCEEDING 400 FT. IN LENGTH, DATED 1959

ALLOWABLE STRESSES

F_t (TENSION) STRUCTURAL CARBON STEEL	18,000 LB/in^2
F_s (TENSION) REINFORCING BARS	20,000 LB/in^2
F_c (FLEXURE) CONCRETE	3,500 LB/in^2
f_c (FLEXURE) CONCRETE WITHOUT EARTH PRESSURE	1,800 LB/in^2
f_c (FLEXURE) CONCRETE WITH EARTH PRESSURE	800 LB/in^2
v (TORTIONS) = $75 LB/in^2$	$n = 10$

FOUNDATIONS
 ABUTMENTS AND PIERS ON SPREAD FOOTINGS.
 ALLOWABLE PRESSURE ON ABUTMENTS 1,200 - 8,000 psf
 ALLOWABLE PRESSURE ON PIERS 1,200 - 8,000 psf

APPROVED BY C.B.N.R.D.
 CHIEF ENGINEER

DEPARTMENT OF HIGHWAYS COOK COUNTY, ILLINOIS	
ROBERT STAN	GALLAGHER J. HOFFMEIER
PLAN AND ELEVATION C.B.N.R.D., C.B.W.I.R.D. AND R.L.T. BY STRUCTURE SOUTH ROUTE EXPRESSWAY NORTH OF 91 ST STREET	
ALFRED BEMISE & ASSOCIATES CHIEF ENGINEER	FORNOLD, BIGGS & SUTHERLAND SCALE 1/8\"/>
DATE	DESCRIPTION

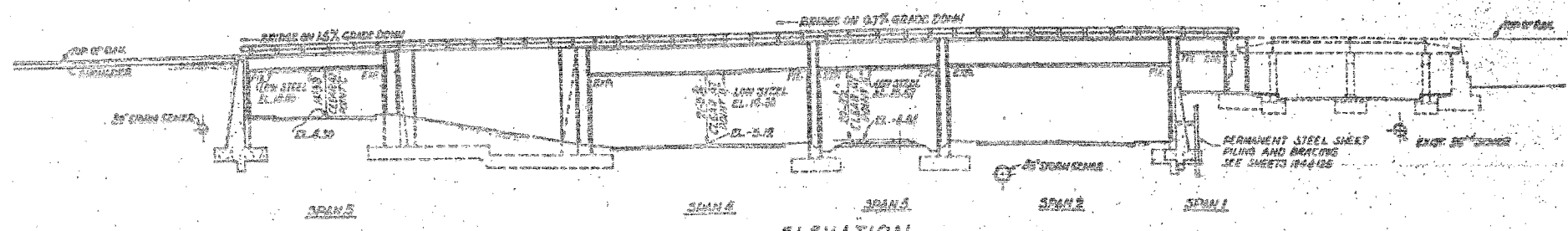

ELEVATION
SCALE: 1/8" = 1'-0"

Handwritten calculation:

$$\begin{array}{r} 4 \quad 03.24 \\ 1 \quad 00.32 \\ \hline 3 \quad 02.92 \\ \quad 9.8 \\ \hline 3 \quad 12.72 \\ \quad 1.42 \\ \hline 3 \quad 14.14 \end{array}$$

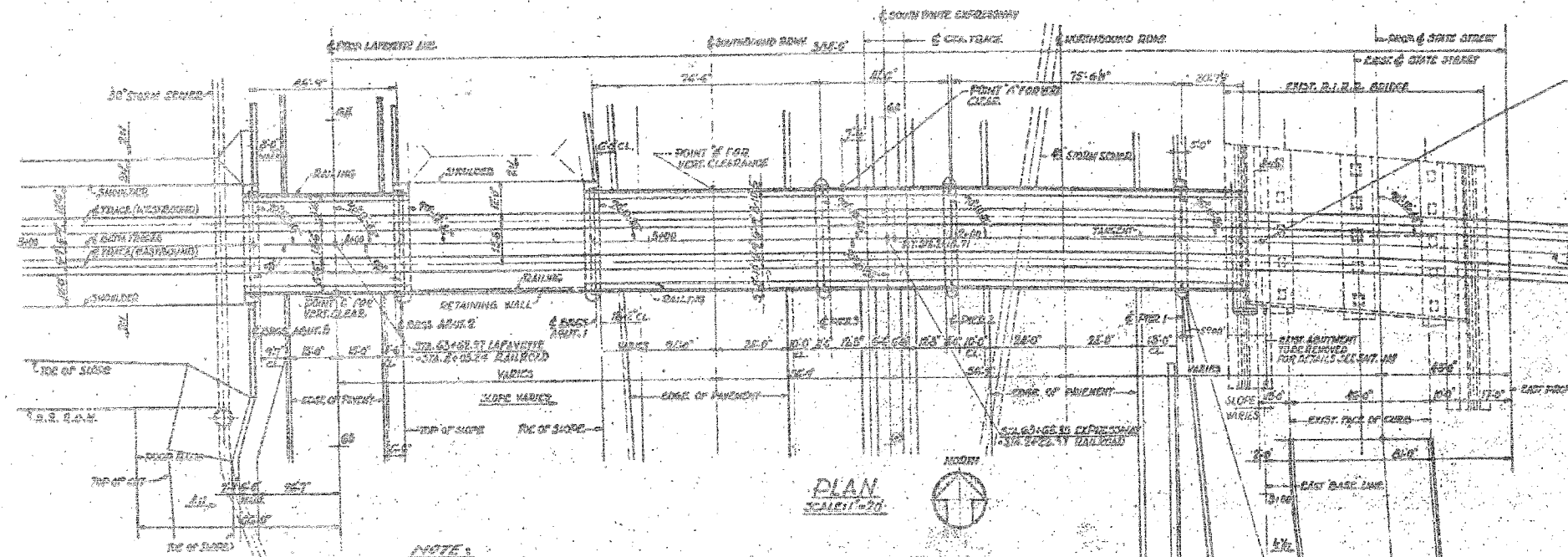

PLAN
SCALE: 1/8" = 1'-0"

NOTE:
FOR CROSS SECTIONS SHOWING ARRANGEMENT OF BALLAST ON EMBANKMENT SEE SHEET 136.

DESIGN DATA

LIVE LOAD
 COOPER E72 PLUS DIESEL IMPACT

SPECIFICATIONS
 DESIGN IN ACCORDANCE WITH A.S.T.M. SPECIFICATIONS FOR STEEL RAILWAY BRIDGES FOR FIXED SPANS NOT EXCEEDING 400 FEET IN LENGTH, DATED 1959

ALLOWABLE STRESSES

f_y (TENSION) STRUCTURAL CARBON STEEL	15,000 LB_3/IN^2
f_y (TENSION) REINFORCING BARS	20,000 LB_3/IN^2
f_c (FLEXURE) CONCRETE	5,500 LB_3/IN^2
f_c (FLEXURE) CONCRETE ADJUST. EARTH PRESSURE	1,400 LB_3/IN^2
f_c (FLEXURE) CONCRETE ADJUST. EARTH PRESSURE	800 LB_3/IN^2
v (SHEAR) CONCRETE	1.0 LB_3/IN^2

FOUNDATIONS
 ADJUSTMENT AND PILES ON GRADED SOFTENED
 ALLOWABLE PRESSURE ON ADJUSTMENT 1 & 2 PILES = 2,000 P.S.F.
 ALLOWABLE PRESSURE ON ADJUSTMENT 3 = 1,000 P.S.F.
 ALLOWABLE PRESSURE ON ADJUSTMENT 4 = 1,000 P.S.F.

APPROVED BY CHIEF ENGR.

 ENGINEER OF BRIDGES

DEPARTMENT OF HIGHWAYS
 COOK COUNTY, ILLINOIS

PLAN AND ELEVATION
 C.R.I. & D.R.R.
 SOUTH ROUTE EXPRESSWAY NORTH OF 9TH STREET

ALFRED BRIDGES & ASSOCIATES
 CONSULTING ENGINEERS
 100 N. LAURELWOOD ROAD, CHICAGO, ILL. 60642

DATE: 10/19/59
 BY: [Signature]
 DESCRIPTION: [Signature]

REVISIONS	
NAME	DATE