

Structural Geotechnical Report
Box Culvert Replacement Project

Chicago to St. Louis High Speed Rail
Hoff Road, Mile Post 46.64
Elwood, Illinois
Will County

IDOT PTB 890-172
DOT# 290492F

Project Design Engineer
AECOM
345 East Ash Avenue
Decatur, Illinois 62526

Geotechnical Consultant
GSG Consultants, Inc.
312-733-6262

September 18, 2015
Revised November 18, 2015



GSG CONSULTANTS, INC.

855 West Adams, Suite 200
Chicago, Illinois 60607
tel: 312.733.6262
fax: 312.733.5612

Structural Geotechnical Report
Box Culvert Replacement Project
Chicago to St. Louis High Speed Rail
Hoff Road
Mile Post 46.64
Elwood, Illinois
Will County

IDOT PTB 890-172
DOT# 290492F

Prepared by: 
Naser Elsbihi, M.E., E.I.
Staff Engineer

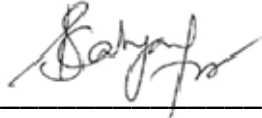
Reviewed by: 
Kalyan Chandhuri, M.S., P.E.
Senior Engineer

Approved by: 
Ala E. Sassila Ph.D., P.E.
Principal



Table of Contents

1.0	INTRODUCTION.....	2
1.1	Project Information.....	2
1.2	Existing Subsurface Information	3
2.0	SUBSURFACE EXPLORATION	4
2.1	Subsurface Site Investigation.....	4
2.2	Laboratory Testing Program	5
2.3	Subsurface Soil Conditions	5
2.4	Groundwater Conditions	6
3.0	GEOTECHNICAL ANALYSIS.....	7
3.1	Derivation of Soil Parameters for Design	7
3.2	Seismic Parameters.....	8
3.3	Scour Considerations	9
3.4	Settlement	9
4.0	GEOTECHNICAL RECOMMENDATIONS	10
4.1	Bearing Resistance	10
4.2	Lateral Earth Pressures.....	11
5.0	CONSTRUCTION CONSIDERATIONS.....	13
5.1	Stage Construction.....	13
5.2	Site Preparation.....	14
5.3	Site Excavation	14
5.4	Borrow Material and Compaction Requirements	15
5.5	Groundwater Management	15
6.0	LIMITATIONS	17



Appendices

Appendix A	Soil Boring Location Plan and Subsurface Profile
Appendix B	Soil Boring Logs
Appendix C	Laboratory Test Results
Appendix D	Unsuitable Excavation Treatment for Culverts



1.0 Introduction

GSG Consultants, Inc. (GSG) completed a geotechnical investigation for the installation of box culvert replacement at the intersection of Illinois Route 53 and Hoff Road in Elwood, Illinois. The proposed improvement is part of the Chicago to St. Louis High Speed Rail project. The purpose of the investigation was to explore and characterize the subsurface soil and groundwater conditions to determine engineering properties of the subsurface soil, and develop design and construction recommendations for the box culvert replacement project. Figure 1 shows the project location map.



Figure 1: Project Location Map, from USGS Topography Quadrangle of Elwood IL

1.1 Project Information

Based on information and drawings provided by AECOM, GSG understands that the proposed box culverts will replace the existing culverts that are located between Station 76+04 to Station 77+90 of Illinois Route 53. The existing culverts consist of a cast in place concrete box structures that extend below Hoff Road at the first location and below an unnamed access road to the south of Hoff Road at the second location to the east of Illinois Route 53. The two culverts convey an unnamed waterway from north to south under the roadways.



The Hoff Road culverts consist of two adjacent culverts running parallel to each other in a north south direction underneath the roadway. The existing culverts; a 3 feet wide by 3 feet high box culvert that extends approximately 88 feet in length and a 5 feet wide by 3 feet high box culvert that extends approximately 82 feet in length with headwalls on the north side convey runoff water from north to south. The proposed improvements will include the complete removal of the existing culverts and headwalls and replacement with the construction of one new box culvert. The proposed culvert will have an overall length of approximately 105 feet, and will be 10 feet wide and 3 feet high. The grading changes will be minimal and the pitch of the culverts will change from 0.26% and 0.32% to 0.31%. The new invert elevations are expected to change by approximately 1 foot below the existing inverts.

The access road culvert consists of one, 7 feet wide by 4 feet high, box culvert that extends approximately 24 feet in length underneath the unnamed access road just south of Hoff Road with headwalls on the north inlet and south outlet. The proposed improvements will include the complete removal of the existing culvert and headwalls and the construction of a new box culvert. The proposed culvert will have an equal length of approximately 24 feet, and will be 12 feet and 4 feet high. The grading pitch of the culvert will change from 0.00% to 1.16%. The new invert elevations are expected to change by approximately 1 foot below the existing inverts.

1.2 Existing Subsurface Information

GSG reviewed several published documents in an effort to determine the regional geological setting in the area of the Site. The subject area is located in the southwest portion of Will County, Illinois. The surficial geologic deposits in this area are typically glacial drift deposited during the Wisconsin Glacial Age. This project is located geographically in the Rockdale Moraine, part of the Valparaiso Morainic System of the Yorkville Member of the Wedron Group. This moraine is primarily silty, sandy, or gravelly till with local areas of silty clayey till, many lenses of poorly sorted gravel, and abundant small kames. This formation overlies the Silurian Elwood Bedrock Formation which consists of interbedded layers of dolomite with depths ranging from 50 to 80 feet.

The project area is approximately 5 miles south of the Sandwich Fault Zone. The Sandwich fault zone is one of the longest fault zones in Illinois and extends northwesterly approximately 85 miles between Manhattan in Will County to Oregon in Ogle County. The fault zone has a maximum displacement of approximately 800 feet at its midpoint in southeastern DeKalb County and is approximately ½ to 2 miles in width



2.0 Subsurface Exploration

This section describes the subsurface exploration program and laboratory testing program completed as part of this project. The locations of the soil borings were provided by AECOM, and were completed based on field conditions and accessibility. The locations of the soil borings are shown on the **Soil Boring Location Plan and Subsurface Profile (Appendix A)**. The subsurface exploration program was performed in accordance with applicable IDOT geotechnical manuals and procedures. Soil Borings were advanced to a depth of 40 feet below the existing ground surface at each location.

2.1 Subsurface Site Investigation

The subsurface investigation was conducted on September 8th, 2015, and included advancing a total of five (5) standard penetration test (SPT) for foundation borings of nearby traffic signal structures. Two (2) borings within the vicinity of the proposed culvert were extended to 40 feet per IDOT geotechnical manual requirements and were used as part of this investigation. Table 1 below presents a list of the borings pertaining to the new culvert.

Table 1 – Summary of Subsurface Exploration Borings

Location	Illinois Route 53 Station	Soil Boring	Depth (ft)	Existing Ground Elevation
East side of IL. Rte. 53 south of Hoff Road	76+80	FB-4	40	631.01
East side of IL. Rte. 53 North of Hoff Road	78+10	FB-5	40	632.68

Note: FB-1, FB-2 and FB-3 were drilled west of IL Rt. 53 for the traffic signal and are not part of this report.

The soil borings were drilled using a Diedrich D-50 truck mounted drill rig. All of the borings were drilled using 3¼-inch I.D. hollow stem augers. Soil sampling was performed according to AASHTO T 206, "Penetration Test and Split Barrel Sampling of Soils." Soil samples were obtained with the use of a split spoon sampler, at intervals of 2.5 feet to a depth of 30 feet, and then at 5 foot intervals thereafter. GSG's field representative inspected, visually classified and logged the soil samples during the subsurface exploration activities, and performed unconfined compressive strength tests on cohesive soil samples using a calibrated Rimac compression



tester and a calibrated hand penetrometer in accordance with IDOT procedures and requirements. Representative soil samples were collected from each sample interval, and were placed in jars and returned to the laboratory for further testing and evaluation. GSG field crew also measured the ground elevation using an automatic level and a bench mark at the intersection of Illinois 53 and Hoff Road. The existing ground surface elevations shown in the soil boring logs are based on field survey completed by GSG field crew using a bench mark CP 166 with an elevation of 632.86 feet MSL.

2.2 Laboratory Testing Program

All samples were inspected in the laboratory to verify the field classifications. A laboratory testing program was undertaken to characterize and determine engineering properties of the subsurface soils encountered in the area of the proposed culvert. The lab testing program included Moisture Content (AASHTO T-265), Atterberg Limits (AASHTO T-89/90) and Dry Unit Weight. The laboratory tests were performed in accordance with test procedures outlined in the IDOT Geotechnical Manual (1999), and per ASTM and AASHTO requirements. Based on the laboratory test results, the soils encountered were classified according to the AASHTO and the Illinois Division of Highways (IDH) classification systems. The results of the laboratory testing program are shown along with the field test results in the **Soil Boring Logs (Appendix B)** and in the **Laboratory Test Results (Appendix C)**.

2.3 Subsurface Soil Conditions

The subsurface soil conditions were developed based on the results of both the site investigation and laboratory results. Detailed descriptions of the subsurface soils, as well as the surface elevations, are provided in the **Soil Boring Logs (Appendix B)**. The soil boring logs provide specific soil conditions encountered at each soil boring location, including: soil descriptions, stratifications, penetration resistance, elevations, location of the samples, water levels (when encountered), and laboratory test data. Variations in the general subsurface soil profile were noted during the drilling activities. The stratifications shown on the boring logs represent the conditions only at the actual boring locations, and represent the approximate boundary between subsurface materials; however, the actual transition may be gradual.

The soil profile at the boring locations consisted of approximately 2 feet of crushed aggregate fill at the surface underlain by cohesive fill materials consisting of clay to a depth of 5 feet below the grade. With the exception of a thin layer of sand noted in boring FB-4 at 17.5 to 18.5 feet below the surface, the soils below the fill materials generally consisted of native cohesive materials through the boring termination depth of 40 feet below the ground surface. The native



cohesive soils were composed of layers of silty clay, clay and silt soils. The representative soil samples collected from the borings were tested and had unconfined compressive strengths ranging from 1.00 to 5.00 tsf.

2.4 Groundwater Conditions

Water levels were checked in each boring to determine the general groundwater conditions present at the site, and were measured while drilling. None of the borings were left open after leaving the site due to safety reasons. Water was encountered in both of the borings while drilling, at elevations between 626.18 and 613.51 feet. Based on the above average rainfall encountered in the months leading to the subsurface investigation and the low permeability of cohesive soils it appears that the water level reading made during the investigation may represent a perched water table condition. It is anticipated that the seasonal ground water level may be closer to elevation 617.01 and 614.18 due to the color transition from brown and gray to gray in the soils. The brown color of the soil is typically caused by oxidation that occurs above the long term water level. This color transition did not occur at a consistent elevation in all of the borings, which may indicate seasonal fluctuations from the above average rainfall and climatic conditions or impacts from the drainage of the surrounding area.



3.0 Geotechnical Analysis

This section provides GSG's geotechnical analysis and recommendations for the design of the proposed culvert based on the results of the field exploration, laboratory testing, and geotechnical analysis. Based on information and drawings provided by AECOM, GSG understands that the existing box culverts underneath Hoff Road and the nearby access road will be replaced as part of the high speed rail project. The proposed culverts will consist of a 10 feet wide by 3 feet high box culvert and a 12 feet wide by 4 feet high box culvert. Based on the plans provided, the invert elevations for the proposed culvert will be approximately 1 foot below those of the existing culverts. It is anticipated that the construction of the proposed culvert will require minimal grading and fill placement. The Soil Boring Location Plan, shows the proposed culvert and subsurface soil profile at the location of the soil borings.

3.1 Derivation of Soil Parameters for Design

GSG determined the geotechnical parameters to be used for the project design based on the results of field and laboratory test data on individual boring logs as well as our experience. Unit weights, friction angles and shear strength parameters were estimated using corrected standard penetration test (SPT) results using published correlations for N values for the fill and cohesionless soils and in-situ and laboratory test results for cohesive soils. The SPT values were corrected for hammer efficiency. The hammer efficiency correction factor considers the use of a safety hammer/rope/cat-head system, generally estimated to be 60% efficient. Thus, correlations should be based upon what is currently termed as N_{60} data. The efficiency of the automatic hammer used for this exploration was estimated to be approximately 80% based on previous efficiency testing of the drill rigs equipped with such equipment. The correction for hammer efficiency is a direct ratio of relative efficiencies as follows:

$$N_{60} = N * (80/60)$$

* Where the N value is the field recorded blow counts

Table 2 presents generalized soil parameters to be used for design based on the laboratory and in-situ testing data:



Table 2 – Summary of On-site Soil Parameters

Depth/Elevation (feet)	Soil Description	In situ Unit Weight γ (pcf)	Undrained		Drained	
			Cohesion c (psf)	Friction Angle ϕ (Degrees)	Cohesion c (psf)	Friction Angle ϕ (Degrees)
	Proposed Granular Fill	120	0	30	0	30
(632 to 630) 0 to 2	Existing Granular Fill	120	0	30	0	30
(630 to 627) 2 to 5	Black and Gray Clay Fill	120	1,000	0	0	26
(627-621) 5 to 11	Stiff Clay	130	1,500	0	0	28
(621- 592) 11 to 40	Very Stiff to Hard Silty Clay	135	3,500	0	100	30
(603 – 592) *29 to 35	Glacial Till – Silt	140	1,500	15	250	30

*Layer noted in boring FB-4 only

3.2 Seismic Parameters

The seismic hazard for the site was analyzed per the IDOT Geotechnical Manual, IDOT Bridge Design Manual, and AASHTO LRFD Bridge Design Specifications.

The Seismic Soil Site Class was determined per the requirements of All Geotechnical Manual Users (AGMU) Memo 9.1, Design Guide for Seismic Site Class Determination, and the “Seismic Site Class Determination” Excel spreadsheet provided by IDOT. A global Site Class Definition was determined for this project, and was found to be Soil Site Class C. The Seismic Performance Zone (SPZ) was determined using Figure 2.3.10-3 in the IDOT Bridge Manual, and was found to be Seismic Performance Zone 1. The AASHTO Seismic Design Parameters program was used to determine the peak ground acceleration coefficient (PGA), and the short (S_{Ds}) and long (S_{D1}) period design spectral acceleration coefficients for each of the proposed structures. For this section of the project, the S_{Ds}



and the S_{D1} were determined using 2014 AASHTO Guide Specifications as shown in Table 3. Given the site location and materials encountered, the potential for liquefaction is minimal.

Table 3– Seismic Parameters

Building Code Reference	PGA	S_{DS}	S_{D1}
2014 AASHTO Guide for LRFD Seismic Bridge Design	0.049g	0.127g	0.069g

3.3 Scour Considerations

Per Section 2.3.6.3.2 of the IDOT Bridge Design Manual, the design scour elevation should be taken as the bottom of the cut off wall. With stiff to hard cohesive soils, such as those encountered at the site, the predicted scour depth can be assumed to be 50% of the predicted value for sand.

Concrete wing walls will protect the soil slopes adjacent to the culvert from being eroded by scour. It is recommended that riprap be placed at open ends of the culvert to protect from the effects of scour on the soils within the flow route. IDOT procedures should be followed for determining the dimensions and type of stone to be used, based on the geometry of the proposed culvert, and the volume and flow rate of the water being conveyed. Filter fabric and bedding material below the riprap should also be installed depending on the gradation and type of material used, as based on IDOT procedures specified in Section 281 of the Standard Specifications or Road and Bridge Construction. The construction requirements from this section should also be followed.

3.4 Settlement

GSG estimated the anticipated settlement based on the proposed roadway profile. It is anticipated that minimal grading and fill placement will be required to construct the proposed box culvert. The settlement associated with the construction of the culvert is anticipated be minimal and on the order of less than 1 inch.



4.0 GEOTECHNICAL RECOMMENDATIONS

This section provides recommendation regarding foundation and design parameters for the proposed culvert. The recommendations were developed based on the project information provided by AECOM and the results of the site investigation. If there are any significant changes to the project characteristics or if significantly different subsurface conditions are encountered during construction, GSG should be consulted so that the recommendations of this report can be reviewed. The foundation design recommendations were completed per the AASHTO LRFD 7th Edition (2014).

4.1 Bearing Resistance

Based on the culvert design information provided by AECOM, the inverts of the proposed culverts will be approximately 1 foot below the existing culverts and the bearing grades will be at approximately approximate elevations of 623 to 625 feet. The factored bearing resistance was calculated for the strength limit state and service limit state using LRFD procedures. For the design of the foundation for the culvert, the total live load and dead load, including the load of the overburden soils, should be considered. We recommend using the soil parameters provided above in Table 2 for the overburden material.

The subgrade soils at the bearing grade should be evaluated for suitability prior to placing any portion of the proposed culvert structure. GSG anticipates undercuts on the north end of the culvert running underneath Hoff Road due to the presence of medium stiff to stiff high plasticity clay soils noted within the proposed bearing elevation in boring FB-5. Undercuts of the upper 1 to 2 feet of the moist clay with consistency less than 1.5 tsf will be necessary for the affected areas. All undercut areas below the culvert should be backfilled in accordance with IDOT detail, **Unsuitable Excavation Treatment for Culverts, (Appendix D)**. These undercut areas should be backfilled with material meeting the requirements of the District One Aggregate Subgrade Improvement Special Provision (revised March 3, 2015). The undercut area should also be lined with a woven geotechnical fabric, for ground stabilization. The culvert should be backfilled in accordance with standard IDOT specifications.

Provided by the bearing grade soils are prepared as mentioned above, the bearing capacity values suggested below in the Table 4 should be used for design.



Table 4– Bearing Capacity

Ultimate Bearing (Strength Limit) (psf)	Factor	Factored Resistance (Strength Limit) (psf)	Service Limit (psf)	Recommended Value for Design (psf)
7,710	0.45	3,500	3,500	3,500

The plan drawings do not clearly indicate any head wall, however, if any headwall is required or planned for the proposed culvert then the footings for the headwall should be constructed independently of the box culvert. A foundation system consisting of shallow spread footings could be used to support the proposed culvert head walls and should be placed at a minimum depth of 3 feet below grade for Type L walls or 4 feet below finished grade for Type T Walls (in accordance with IDOT Culvert manual), for frost protection. Also, the footing for the headwall should be placed no less than 2.0 feet below the maximum anticipated scour depth.

4.2 Lateral Earth Pressures

The culvert headwalls shall be designed using relevant LRFD strength and service limit states and load combinations to resist lateral earth loads, vehicular loads, creep, and temperature and shrinkage deformations of the concrete box culvert. Traffic surcharge load of 240 psf, which is equivalent to 2 feet of soil, should be used for the vehicular loads. Lateral earth pressures for permanent underground structures will be dependent on the type of backfill used, whether it is in a drained or undrained state, as well as loading conditions. Wall sections that are independent of the box culvert should be designed using the Rankine active earth pressure coefficient, K_a . Headwall that are fixed to the box culvert to resist movement should be designed using an at-rest earth pressure coefficient. Lateral design parameters provided in the Table 5 below could be used in the design of the proposed structure.

Table 5 – Lateral Earth Pressure Design Parameters

Backfill Type	Unit Weight (pcf) (γ)	Angle of Internal Friction (ϕ)	Active Earth Pressure Coefficient (K_a)	At-Rest Earth Pressure Coefficient (K_o)	Passive Earth Pressure Coefficient (K_p)
Granular	120	30	0.33	0.5	3.0
Cohesive	125	28	0.36	0.53	2.77

The backfill behind the wall should be placed and compacted in accordance with the IDOT 2012



Bridge Manual. Heavy compaction equipment should not be used on the high side of the wall within a horizontal distance equal to the height of backfilling, as this may result in overstressing of the wall and excessive deflection.



5.0 Construction Considerations

All work performed for the proposed project should conform to the requirements in the IDOT Standard Specifications for Road and Bridge Construction (2012) along with the IDOT Subgrade Stability Manual (2005). Any deviation from the requirements in the manuals above should be approved by the design engineer.

5.1 Stage Construction

A temporary soil retention system may be required in several locations and at various stages to excavate for the construction of proposed culvert and walls. If staged construction will be utilized for the construction of the proposed improvements to allow traffic to be maintained during construction, there will be a need for near vertical excavation along the centerline of the roadway to facilitate the construction of the culvert. The Temporary Soil Retention Systems should include surcharge loads from the excavated materials, construction equipment, and trucks. The retention system should extend to a sufficient depth below excavation bottom to provide the required lateral passive resistance if the active case is used for the design. Embedment depths should be determined based on the principles of force and moment equilibrium. The retention system should be designed for at-rest condition if the adjacent roadway section cannot withstand the anticipated horizontal and vertical movements of the construction excavation. The retention system shall be designed by an Illinois licensed structural engineer in accordance with the IDOT Bridge Design Manual.

Based on the anticipated conditions needed for staged construction, GSG anticipates sheet pile walls as a viable option for temporary earth retention systems. The values show in Table 6 may be used for the design of the temporary soil retention system.



Table 6– Soil Retention System Design Data

Elev. Depth (feet)	Soil Description	Active Earth Pressure Coefficient (K_a)	Passive Earth Pressure Coefficient (K_p)	At Rest Earth Pressure Coefficient (K_o)	Lateral Modulus of Subgrade Reaction (pci)	Soil Strain (ϵ_{50})
	Proposed Granular Fill	0.33	2.99	0.50	90	NA
0 to 2	Existing Granular Fill	0.33	2.99	0.50	90	NA
2 to 5	Black and Gray Clay Fill	0.39	2.56	0.80	500	0.007
5 to 11	Stiff Clay	0.36	2.77	1.00 ⁺	750	0.007
11 to 40	Very Stiff to Hard Silty Clay	0.33	2.99	1.00 ⁺	1,750	0.005
*29 to 35	Glacial Till - Silt	0.36	2.75	1.00 ⁺	1,000	0.005

*Layer noted in boring FB-4 only

+ Over Consolidation Ratio (OCR) for these soil layers ranged between 4 and 6

The recommended soil parameters listed in the above table should be used to determine earth pressures acting on the soil retention system. The selected earth retention system should be also designed for surcharge loading due to surface loads within the zone of the proposed backfill. Traffic loads are applicable only if the traffic lane is located horizontally from the face of the wall within a distance equal or less than one-half of the wall height. At a minimum, a uniform vertical pressure of 240 psf should be considered in the design for traffic load. Other loads should be also evaluated using the procedures of AASHTO LRFD Section 3.11.6.

5.2 Site Preparation

All vegetation, surface topsoil, and debris should be cleared and stripped where fills will be placed. Undercuts of the subgrade soils and backfilling should be based on the recommendations provided in Section 4.1 of this report, or based on field evaluation of the materials encountered during construction. Any unstable or unsuitable materials encountered during construction activities should be removed and replaced with compacted structural fill. GSG anticipates approximately between 1 and 2 feet of structural fill in the proposed undercut area.

5.3 Site Excavation

Site excavations are expected to encounter various types of soils as described in Subsurface



Exploration section of this report. The contractor will be responsible to provide a safe excavation during the construction activities of the project. All excavations should be conducted in accordance with applicable federal, state, and local safety regulations, including, but not limited to the Occupational Safety and Health administration (OSHA) excavation safety standards. Excavation stability and soil pressures on temporary shoring are dependent on soil conditions, depth of excavations, installation procedures, and the magnitude of any surcharge loads on the ground surface adjacent to the excavation. Excavation near existing structures and underground utilities should be performed with extreme care to avoid undermining existing structures. Excavations should not extend below the level of adjacent existing foundations or utilities unless underpinning or other support is installed. It is the responsibility of the contractor for field determinations of applicable conditions and providing adequate shoring for all excavation activities.

5.4 Borrow Material and Compaction Requirements

Backfill for the culvert should consist of PGE per IDOT ABD Memo 11.3. If borrow material is to be used for onsite construction, it should conform to Section 204 “Borrow and Furnish Excavations” of the IDOT Construction Manual (2012). The fill material should be free of organic matter and debris, and should be placed and compacted in accordance with Section 205, Embankment, of the IDOT Construction Manual. Earth-moving operations should be avoided during excessively cold or wet weather to avoid freezing or softening subgrade soils. Fill should be placed in lifts and compacted according to Section 205, Embankment (IDOT, 2012). All backfill materials around the culvert and wing-walls must be pre-approved by the site engineer. Backfill materials for undercut areas beneath the culvert and wingwalls should be placed in 8 inches loose lifts and should be compacted to 95% of the maximum dry density as determined by AASTHO T-180, Modified Proctor Method.

5.5 Groundwater Management

The existing fill and native soils may be saturated and water seepage may be encountered during excavation. The groundwater may be trapped in layers and lenses of coarse-grained soil overlying native soils. This seepage will be temporary but there may be localized sloughing and near-surface instability of some soil slopes. The contractor should control groundwater and surface water infiltration to provide a dry condition for construction. Temporary ditches, sumps, granular drainage blankets, stone ditch protection, or hand-laid riprap with geotextile underlayment could be used to divert groundwater if significant seepage is encountered during construction. If water seepage occurs during footing construction or where wet conditions are encountered, such that the water cannot be removed with conventional sumping, we recommend placing open grade stone similar to IDOT CA-7 to stabilize the bottom of the excavation below the water table. The CA-7 stone should be placed to 12 inches above the water table, in 12-inch lifts, and should be compacted with the use



of a heavy smooth drum roller or heavy vibratory plate compactor until stable. The remaining portion of the excavation beneath the footings should be backfilled using approved structural fill.



6.0 Limitations

This report has been prepared for the exclusive use of AECOM and its design team, and the Illinois Department of Transportation. The recommendations provided in the report are specific to the project described herein, and are based on the information obtained from the soil boring locations within the proposed roadway project limits. The analyses have been performed and the recommendations have been provided in this report are based on subsurface conditions determined at the location of the borings. This report may not reflect all variations that may occur between boring locations or at some other time, the nature and extent of which may not become evident until during the time of construction. If variations in subsurface conditions become evident after submission of this report, it will be necessary to evaluate their nature and review the recommendations presented herein.



APPENDIX A

**SOIL BORING LOCATION PLAN
AND SUBSURFACE PROFILE**

STA 56+93.28 HOFF RD. =
 STA 76+80.64 IL ROUTE 53

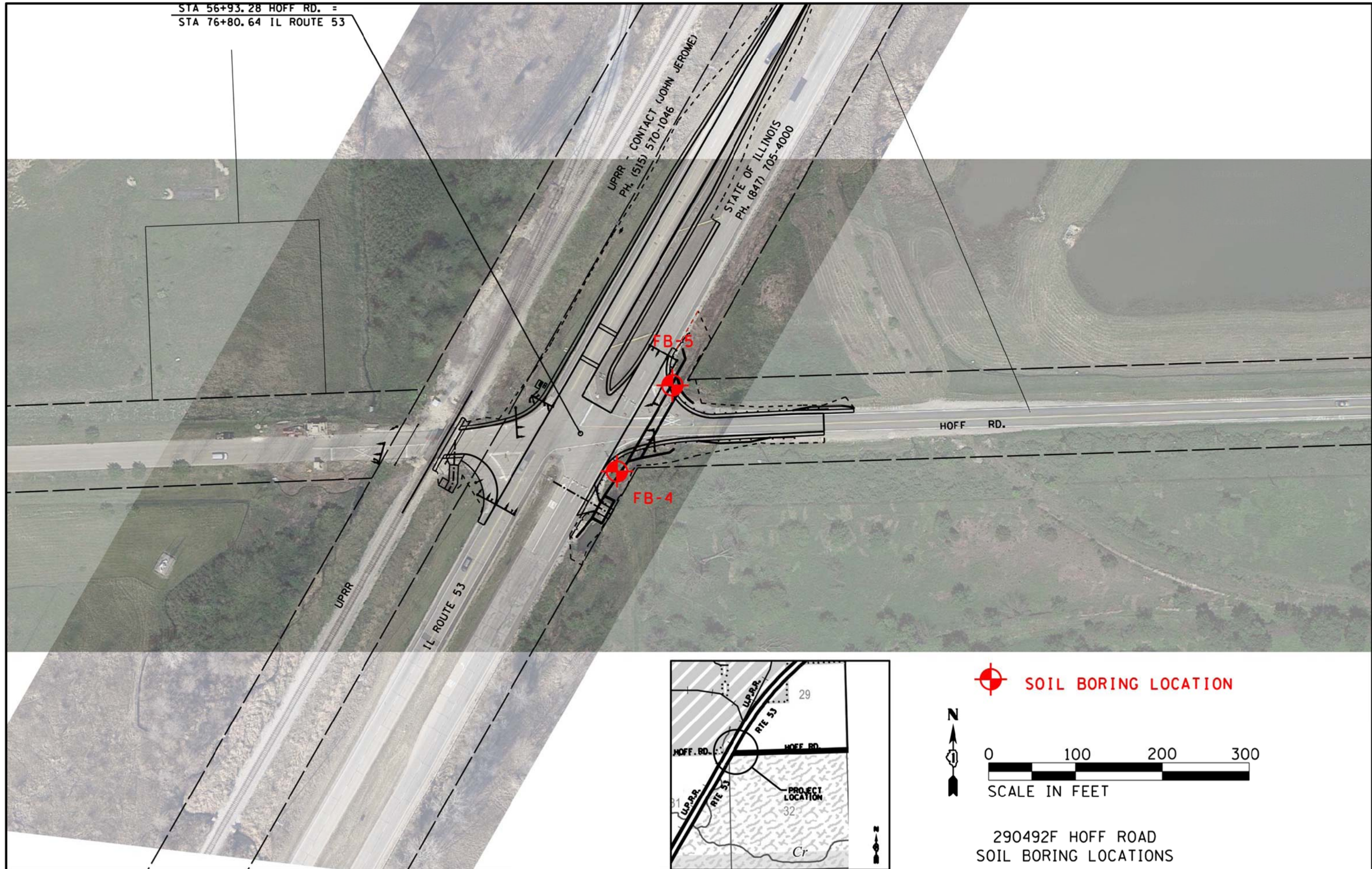

 SOIL BORING LOCATION



290492F HOFF ROAD
 SOIL BORING LOCATIONS

 GSG CONSULTANTS, INC.
 855 West Adams, Suite 200
 Chicago, Illinois 60607
 tel: 312.733.6262 • fax: 312.733.5612

USER NAME * #USER*	DESIGNED - NE	REVISED -
	DRAWN -	REVISED -
PLOT SCALE * #SCALE*	CHECKED - DE	REVISED -
PLOT DATE * #DATE*	DATE - 9/18/15	REVISED -

STATE OF ILLINOIS
 DEPARTMENT OF TRANSPORTATION

290492F HOFF ROAD
 SOIL BORING LOCATIONS
 SCALE: NTS SHEET 1 OF 1 SHEETS STA. TO STA.

F.A. RTE.	SECTION	COUNTY	TOTAL SHEETS	SHEET NO.
846	DDI HSR 2016-01	WILL	1	1
CONTRACT NO. 890-172				
ILLINOIS FED. AID PROJECT				

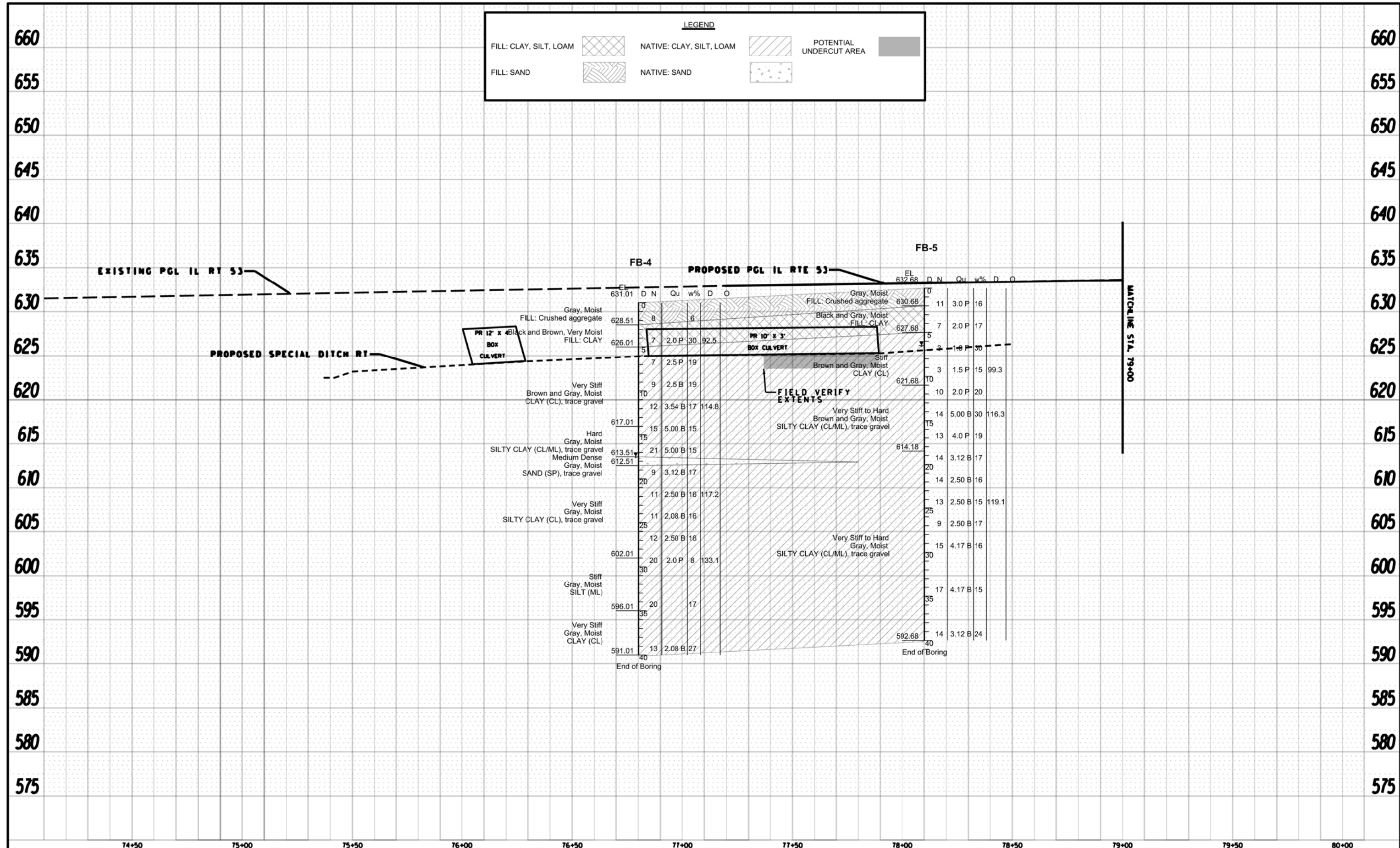

PLAN	SUBMITTED	DATE
	PLOTTED	
	GRADES CHECKED	
	ALIGNMENT CHECKED	
	AS-BUILT FILE NAME	
	NO.	

PROFILE	SUBMITTED	DATE
	PLOTTED	
	GRADES CHECKED	
	STRUCTURE NOTATIONS CHECKED	
	NO.	

APPENDIX B
SOIL BORING LOGS



SOIL BORING LOG

ROUTE IL Rte. 53 & Hoff Rd. DESCRIPTION High Speed Rail from Chicago to St. Louis LOGGED BY JR

SECTION Mile Post 46.64 LOCATION Hoff Road Northing 1721472.7763 Easting 1043839.3169

COUNTY Will DRILLING METHOD HSA HAMMER TYPE AUTO

STRUCT. NO. NA
Station NA

BORING NO. FB-4
Station 57+33
Offset 46.00ft RT
Ground Surface Elev. 631.01 ft

DEPTH (ft)	GRAPHIC LOG	BLOWS (/6")	UCS (tsf)	MOIST (%)	DRY DENSITY (pcf)	ORGANIC (%)
------------	-------------	-------------	-----------	-----------	-------------------	-------------

Surface Water Elev. NA ft
Stream Bed Elev. NA ft
Groundwater Elev.:
First Encounter 613.5 ft ▼
Upon Completion None ft
After NA Hrs. NA ft

NOTES:

Gray, Moist FILL: Crushed aggregate	8 6 2			6		
628.51						
Black and Brown, Very Moist FILL: CLAY	3 3 4		2.0	30	92.5	
626.01						
Very Stiff Brown and Gray, Moist CLAY, trace gravel, A-7-6	2 3 4		2.5	19		
	6 4 5		2.5 B	19		
-10						
	3 5 7		3.5 B	17	114.8	
617.01						
Hard Gray, Moist SILTY CLAY, trace gravel, A-6	7 8		5.0 B	15		
	5 7 14			5.0 B	15	
613.51 ▼						
Medium Dense Gray, Moist SAND, A-3	2					
612.51						
Very Stiff Gray, Moist CLAY, trace gravel A-7-6	4 5		3.1 B	17		
-20						

The Unconfined Compressive Strength (UCS) Failure Mode is indicated by (B-Bulge, S-Shear, P-Penetrometer)
The SPT (N value) is the sum of the last two blow values in each sampling zone (AASHTO T206)



SOIL BORING LOG

ROUTE IL Rte. 53 & Hoff Rd. DESCRIPTION High Speed Rail from Chicago to St. Louis LOGGED BY JR

SECTION Mile Post 46.64 LOCATION Hoff Road Northing 1721472.7763 Easting 1043839.3169

COUNTY Will DRILLING METHOD HSA HAMMER TYPE AUTO

STRUCT. NO. NA
Station NA

BORING NO. FB-4
Station 57+33
Offset 46.00ft RT
Ground Surface Elev. 631.01 ft

DEPTH (ft)	GRAPHIC LOG	BLOWS (/6")	UCS (tsf)	MOIST (%)	DRY DENSITY (pcf)	ORGANIC (%)
3						
4		2.5		16	117.2	
7		B				
3						
4		2.1		16		
7		B				
3						
5		2.5		16		
7		B				
4						
9		2.0		8	133.1	
11						
4						
9				17		
11						
5						
6		2.1		27		
7		B				

Surface Water Elev. NA ft
 Stream Bed Elev. NA ft
 Groundwater Elev.:
 First Encounter 613.5 ft ▼
 Upon Completion None ft
 After NA Hrs. NA ft

NOTES:

Very Stiff
Gray, Moist
CLAY, trace gravel A-7-6
(continued)

602.01

Stiff
Gray, Moist
SILT, A-4

596.01

Very Stiff
Gray, Very Moist
CLAY, A-7-6

591.01

End of Boring

The Unconfined Compressive Strength (UCS) Failure Mode is indicated by (B-Bulge, S-Shear, P-Penetrometer)
The SPT (N value) is the sum of the last two blow values in each sampling zone (AASHTO T206)



SOIL BORING LOG

ROUTE IL Rte. 53 & Hoff Rd. DESCRIPTION High Speed Rail from Chicago to St. Louis LOGGED BY JR

SECTION Mile Post 46.64 LOCATION Hoff Road Northing 1721572.1243 Easting 1043903.3096

COUNTY Will DRILLING METHOD HSA HAMMER TYPE AUTO

STRUCT. NO. NA
Station NA

BORING NO. FB-5
Station 58+02
Offset 50.00ft LT
Ground Surface Elev. 632.68 ft

DEPTH (ft)	GRAPHIC LOG	BLOWS (/6")	UCS (tsf)	MOIST (%)	DRY DENSITY (pcf)	ORGANIC (%)
------------	-------------	-------------	-----------	-----------	-------------------	-------------

Surface Water Elev. NA ft
Stream Bed Elev. NA ft
Groundwater Elev.:
First Encounter 626.2 ft ▼
Upon Completion None ft
After NA Hrs. NA ft

NOTES:

Gray, Moist FILL: Crushed aggregate		4				
		5	3.0	16		
630.68		6				
Black and Gray, Moist FILL: CLAY		4				
		3	2.0	17		
627.68		4				
Stiff Dark Gray to Brown, Very Moist CLAY, A-7-6	▼	2				
		1	1.0	30		
		2				
		1				
		1	1.5	15	99.3	
		2				
-10						
621.68		3				
Very Stiff to Hard Brown and Gray, Very Moist SILTY CLAY, A-6		5	2.0	20		
		5				
		4				
		6	5.0	30	116.3	
		8	B			
-15						
		4				
		6	4.0	19		
		7				
614.18						
Very Stiff to Hard Gray, Moist SILTY CLAY, A-6		4				
		7	3.1	17		
		7	B			
-20						

The Unconfined Compressive Strength (UCS) Failure Mode is indicated by (B-Bulge, S-Shear, P-Penetrometer)
The SPT (N value) is the sum of the last two blow values in each sampling zone (AASHTO T206)



SOIL BORING LOG

ROUTE IL Rte. 53 & Hoff Rd. DESCRIPTION High Speed Rail from Chicago to St. Louis LOGGED BY JR

SECTION Mile Post 46.64 LOCATION Hoff Road Northing 1721572.1243 Easting 1043903.3096

COUNTY Will DRILLING METHOD HSA HAMMER TYPE AUTO

STRUCT. NO. NA
Station NA

BORING NO. FB-5
Station 58+02
Offset 50.00ft LT
Ground Surface Elev. 632.68 ft

DEPTH (ft)	GRAPHIC LOG	BLOWS (/6")	UCS (tsf)	MOIST (%)	DRY DENSITY (pcf)	ORGANIC (%)
------------	-------------	-------------	-----------	-----------	-------------------	-------------

Surface Water Elev. NA ft
Stream Bed Elev. NA ft
Groundwater Elev.:
First Encounter 626.2 ft ▼
Upon Completion None ft
After NA Hrs. NA ft

NOTES:

Very Stiff to Hard
Gray, Moist
SILTY CLAY, A-6 (continued)

3						
6						
8			2.5	16		
			B			
3						
5			2.5	15	119.1	
8			B			
3						
4			2.5	17		
5			B			
4						
6			4.2	16		
9			B			
5						
6			4.2	15		
11			B			
4						
6			3.1	24		
8			B			

592.68 -40

End of Boring

The Unconfined Compressive Strength (UCS) Failure Mode is indicated by (B-Bulge, S-Shear, P-Penetrometer)

The SPT (N value) is the sum of the last two blow values in each sampling zone (AASHTO T206)

APPENDIX C

LABORATORY TEST RESULTS

290492F – Hoff Road
Laboratory Test Results

Atterberg Limit Results						
Boring ID	Sample Number	Sample Depth (Below Existing Grade)		Liquid Limit	Plastic Limit	Plasticity Index
		Top (ft.)	Bottom (ft.)			
FB-4	SS-4	8.50	10.00	30.2	16.6	13.6
FB-4	SS-9	21.00	22.50	25.8	14.7	11.1
FB-4	SS-13	33.50	35.00	20.7	16.6	4.1
FB-5	SS-4	8.50	10.00	43.9	17.9	26.0



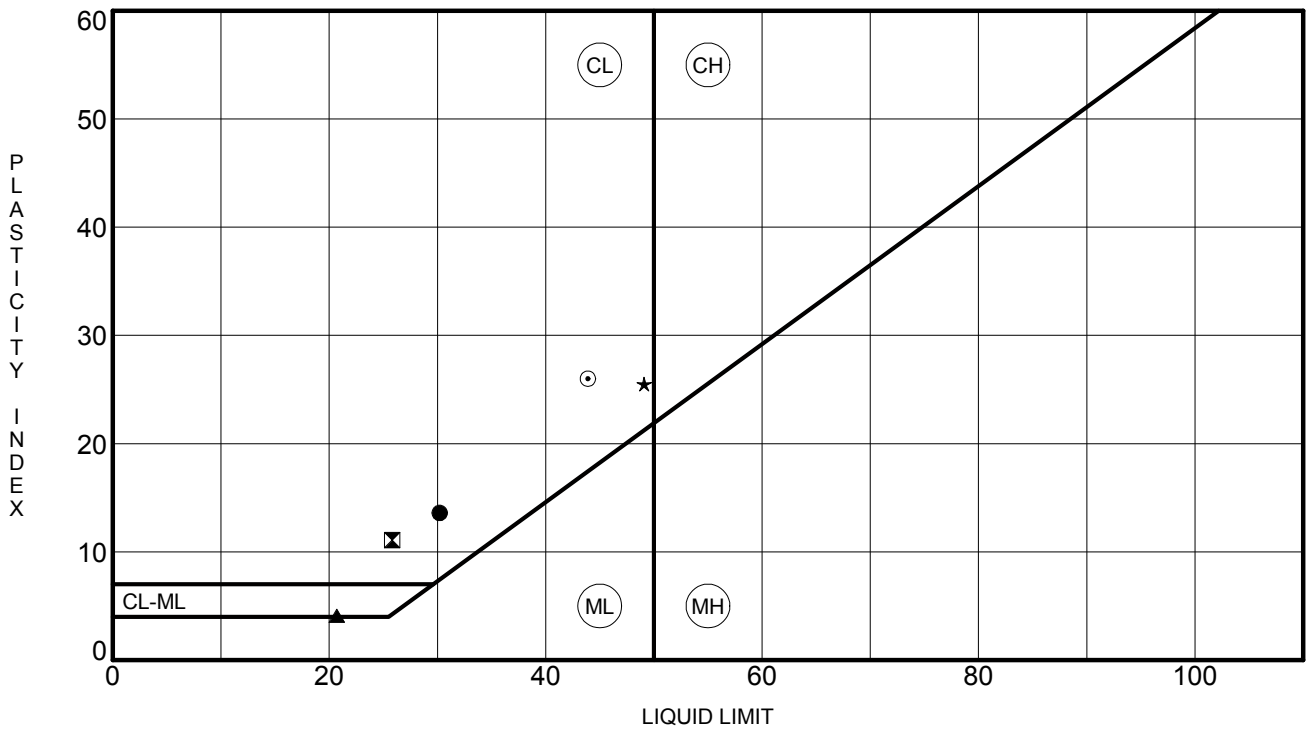

Specimen Identification	LL	PL	PI	Fines	Classification
● FB-4	8.50	30.2	16.6	13.6	
☒ FB-4	21.00	25.8	14.7	11.1	
▲ FB-4	33.50	20.7	16.6	4.1	
★ FB-5	3.50	49.1	23.6	25.5	
⊙ FB-5	8.50	43.9	17.9	26.0	

ATTERBERG LIMITS URS HSR 290492F GINT LOGS.GPJ IL_DOT.GDT 9/14/15

GSG Consultants, Inc
 855 W Adams St, Suite 200
 Chicago, IL 60607
 (312) 733-6262
 Fax: (312) 733-5612

ATTERBERG LIMITS RESULTS

Route: IL Rte. 53 & Hoff Rd.
 Section: Mile Post 46.64
 County: Will

APPENDIX D

UNSUITABLE EXCAVATION TREATMENT FOR CULVERTS

DESIGNER NOTES: 1. CHECK WITH THE DISTRICT GEOTECHNICAL ENGINEER FOR USE OF THIS DRAWING AND FOR UNDERCUT DEPTHS IF NOT PROVIDED OR SHOWN IN PROJECT SOILS REPORT.
 2. ASSURE TREATMENT AREAS ARE SHOWN IN PLANS AND ON CROSS SECTIONS.
 3. INCLUDE SOIL BORINGS FOR TREATED AREAS.

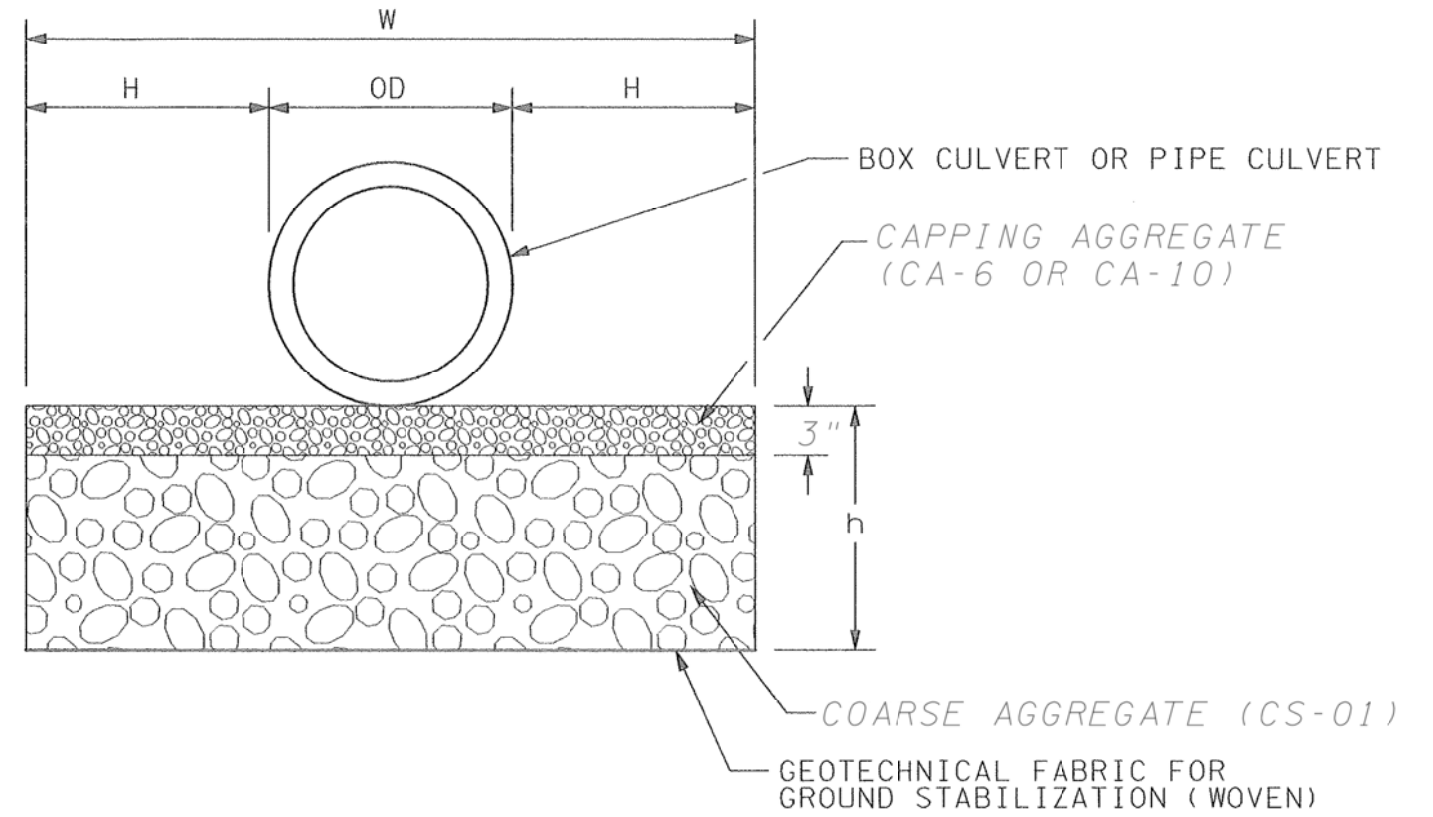

CULVERT LOCATION	UNDERCUT			
	DEPTH	WIDTH		
	H	x	OD	W

GENERAL NOTES:

- Undercut if the Dynamic Cone Penetrometer tests indicate soil strength is less than 1 ton/sq ft.
- DEFINITIONS:
 OD = Outside Diameter or outside width of box culvert
 h = Depth of undercut (for precast box culverts, the upper 6" is included in the cost of culvert).
 x = h or min. width specified in Sec. 542.04, which ever is greater for pipe culverts.
 x = h or minimum 2 feet, which ever is greater for box culverts.
 W = Width of undercut = 2x + OD

All dimensions are in inches (millimeters) unless otherwise noted.

FILE NAME = s:\gen\draft\geom\angie\culvertundercut.dgn	USER NAME = AdadeSA	DESIGNED - DRAWN -	REVISED - REVISED -	STATE OF ILLINOIS DEPARTMENT OF TRANSPORTATION	UNSUITABLE EXCAVATION TREATMENT FOR CULVERTS	F.A. RTE.	SECTION	COUNTY	TOTAL SHEETS	SHEET NO.		
PLOT SCALE = 2.0091' / 1"	PLOT DATE = 6/29/2011	CHECKED - DATE -	REVISED - REVISED -			SCALE:	SHEET NO. OF SHEETS	STA. TO STA.	CONTRACT NO.			
						FED. ROAD DIST. NO.	ILLINOIS FED. AID PROJECT					