

VILLAGE OF BEECHER CITY EFFINGHAM COUNTY, ILLINOIS SAFE ROUTES TO SCHOOL

ROUTE : CHARLES ST., VINE STREET AND JAMES STREET

SECTION: 10-00005-00-SW
JOB # C-40-091-09
PROJECT #SRTS-4009 (078)

INDEX OF SHEETS

- 1 COVER SHEET
- 2 NOTES, QUANTITIES AND SCHEDULES
- 3 GENERAL LAYOUT
- 4 DETAILS
- 5-15 PLAN SHEETS
- 16-23 PROFILES

STANDARDS:

- 424001-08 PERPENDICULAR CURB RAMPS FOR SIDEWALKS
- 424026-01 ENTRANCE/ALLEY PEDESTRIAN CROSSING
- 606001-06 CONCRETE CURB TYPE B AND COMBINATION CONCRETE CURB AND GUTTER
- 701301-04 LANE CLOSURE, 2L, 2W, SHORT TIME OPERATIONS
- 701501-06 URBAN LANE CLOSURE, 2L, 2W, UNDIVIDED
- 701801-06 SIDEWALK, CORNER OR CROSSWALK CLOSURE
- 701901-05 TRAFFIC CONTROL DEVICES
- 720001-01 SIGN PANEL MOUNTING DETAIL
- 720006-04 SIGN PANEL ERECTION DETAIL
- 720011-01 METAL POSTS FOR SIGNS, MARKERS & DELINEATORS
- 780001-05 TYPICAL PAVEMENT MARKINGS

J.U.L.I.E 1-800-892-0123

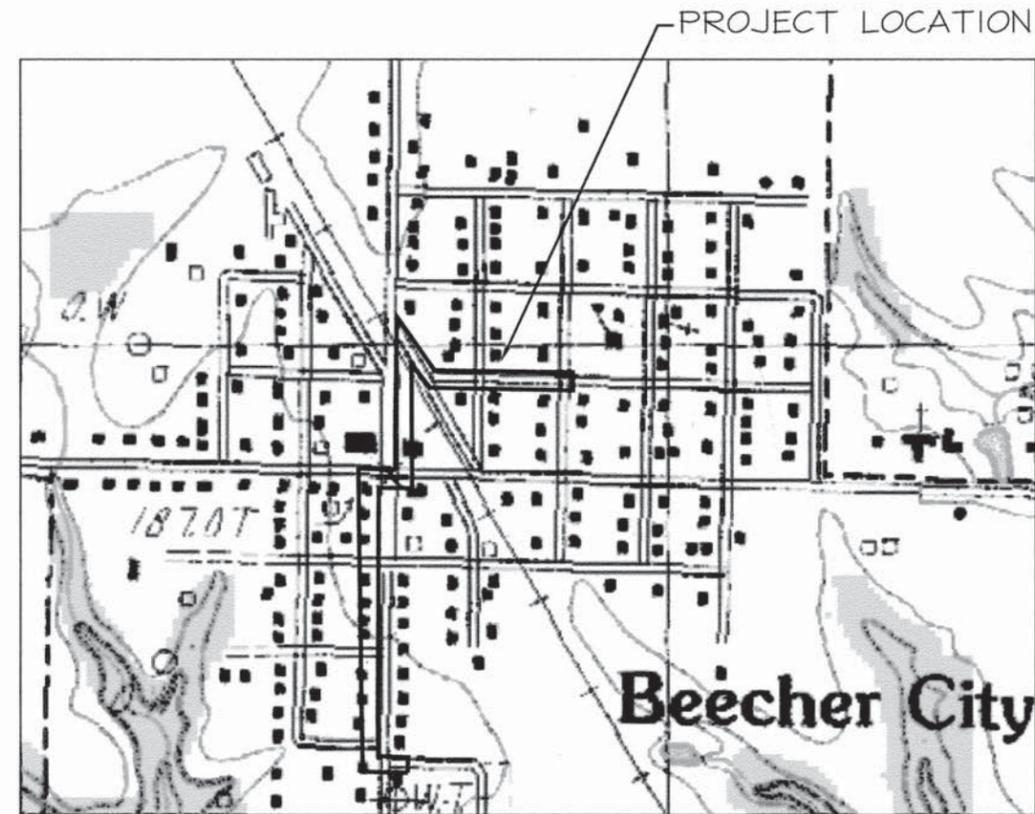

SCALES (24"X36" SHEET) 1 INCH = 10 FEET (HORZ)
SCALES (11"X17" SHEET) 1 INCH = 22 FEET (HORZ)

CHARLES STREET STATION 0+00 - 18+97.66 = 1898 FEET
OIL AND CHIP STREET STATION 18+97.66 - 21+54.28 = 257 FEET
VINE STREET STATION 21+54.28 - 26+84.11 = 530 FEET
JAMES STREET STATION 26+84.11 - 28+00 = 116 FEET
TOTAL LENGTH OF PROJECT 2801 FEET (0.53 MILES)

ENGINEER AND SURVEYOR'S CERTIFICATE
STATE OF ILLINOIS)
COUNTY OF WILLIAMSON)
I, JOHN H. CRAWFORD, ILLINOIS PROFESSIONAL ENGINEER NO. 29206 AND ILLINOIS PROFESSIONAL LAND SURVEYOR NO. 2061 DO HEREBY CERTIFY THAT THESE DRAWINGS WERE PREPARED BY ME, OR PREPARED UNDER MY DIRECT SUPERVISION.
IN WITNESS THEREOF, I HAVE SET MY HAND AND SEAL THIS 1st DAY OF FEBRUARY 2016.

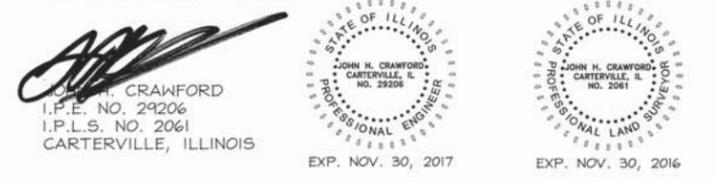

Approved 4-06-2016
Bonnie Schell
PRESIDENT, VILLAGE OF BEECHER CITY

Passed 4-6-16
Margaret Faust
District 7 Engineer of Local Roads and Streets

Releasing for Bid Based on Limited Review 4-6-16
Jeffrey M. Southwick
Region 4 Engineer

NO.	DESCRIPTION	BY	DATE	NO.	DESCRIPTION	BY	DATE
					DESIGNED		
					DRAWN	WFL	07/29/14
					CHECKED	RLP	07/29/14
				A2	REVISED PER IDOT MARKUPS	WFL	02/01/16
				A1	REVISED SET	SLL	8/26/15

VILLAGE OF BEECHER CITY
EFFINGHAM COUNTY, IL
SAFE ROUTES TO SCHOOL
COVER SHEET

JOHN H. CRAWFORD & ASSOCIATES, P.C.
CIVIL ENGINEERS, LAND SURVEYORS
201 SOUTH DIVISION STREET, CARTERVILLE, ILLINOIS 62918
PHONE (618) 985-6370 FAX (618) 985-4692
PROFESSIONAL DESIGN FIRM # 184-002885

SHEET NO.	
1/23	
ISSUE	DATE
A2	02/01/16

P:\proj_2016\02-01-16\Beecher_City_Safe_Routes_to_School\Drawings\02-01-16_SRTS_4009_078.dwg, 4/2/2016, 9:10:57 AM

SUMMARY OF QUANTITIES

CURB REMOVAL

STATION	CURB REMOVAL
	FOOT
CHARLES STREET	
11+95	20
12+00	15
12+55	10
12+75	15
13+11	16
13+23	16
TOTAL=	92

PORTLAND CEMENT CONCRETE SIDEWALK 7 INCH

STATION TO STATION	SQUARE FOOT
	2+48 - 2+69
3+45 - 3+55	49
6+07 - 6+15	38
6+63 - 6+71	36
10+92 - 11+16	59
15+81 - 16+80	496
21+38 - 21+71	150
21+83 - 21+95	56
24+80 - 25+00	95
TOTAL=	1083

CODE #	ITEM DESCRIPTION	TOTAL	UNIT
28100727	STONE DUMPED RIPRAP, CLASS B4	15	SQ YD
42400200	PORTLAND CEMENT CONCRETE SIDEWALK 5 INCH	10,968	SQ FT
42400400	PORTLAND CEMENT CONCRETE SIDEWALK 7 INCH	1083	SQ FT
42400800	DETECTABLE WARNINGS	224	SQ FT
44000300	CURB REMOVAL	92	FOOT
44000600	SIDEWALK REMOVAL	10,527	SQ FT
50901760	PIPE HANDRAIL	40	FOOT
54001001	BOX CULVERT END SECTIONS, CULVERT NO. 1	2	EACH
67100100	MOBILIZATION	1	L SUM
70102620	TRAFFIC CONTROL AND PROTECTION, STANDARD 701501	1	L SUM
72000100	SIGN PANEL - TYPE I	32	SQ FT
72900200	METAL POST - TYPE B	80	FOOT
Δ78001130	PAINT PAVEMENT MARKING - LINE 6"	636	FOOT
ΔX0325714	FLASHING BEACON, POST MOUNTED, SOLAR POWERED INSTALLATION	2	EACH
X2010400	STUMP REMOVAL ONLY	30	UNIT
X2500900	SEEDING, CLASS I (SPECIAL)	0.04	ACRES

DETECTABLE WARNING

STATION TO STATION	SQUARE FOOT
	CHARLES STREET
0+20	10
0+52	10
1+48	10
1+56	10
4+96	10
5+10	10
8+50	10
8+72	12
11+95	12
12+10	10
12+55	10
12+73	10
13+11	20
13+23	20
18+12	10
18+55	10
VINE STREET	
23+18	10
23+34	10
26+46	10
26+62	10
TOTAL=	224

PAINT PAVEMENT MARK - 6" LINE

STATION TO STATION	FEET
	0+40
1+45	30
5+03	28
8+59	40
12+29	174
13+00	154
18+26	84
23+25	33
26+55	33
TOTAL=	636

Δ SPECIALTY ITEMS

GENERAL NOTES

- ALL MATERIALS AND METHODS SHALL BE IN ACCORDANCE WITH STANDARD SPECIFICATIONS FOR ROAD AND BRIDGE CONSTRUCTION, ADOPTED APRIL 1ST, 2016.
- CONTRACTORS SHALL CONTACT EACH UTILITY COMPANY PRIOR TO CONSTRUCTION. ANY DAMAGE CAUSED TO EXISTING UTILITIES SHALL BE THE CONTRACTORS RESPONSIBILITY AND CONTRACTOR SHALL LEND ALL POSSIBLE ASSISTANCE IN RESTORING SERVICE.
- NOT ALL OF THE GAS, POWER OR TELEPHONE LINES, WERE ABOVE OR BELOW GROUND, HAVE BEEN SHOWN ON THE PLANS. THE LOCATION OF EXISTING UNDERGROUND UTILITIES, SUCH AS GAS OR WATER MAINS, ETC., AS SHOWN ON THE PLANS HAVE BEEN DETERMINED FROM THE BEST AVAILABLE INFORMATION AND ARE GIVEN FOR THE CONVENIENCE OF THE CONTRACTOR. THE CONTRACTOR SHALL ASSUME RESPONSIBILITY FOR ALL UTILITIES, WHETHER SHOWN OR NOT, AND MUST REALIZE THAT THE ACTUAL LOCATIONS AND THOSE SHOWN MAY BE DIFFERENT.
- INTERRUPTION OF UTILITY SERVICE IS NOT EXPECTED. HOWEVER, IF INTERRUPTION OF ANY UTILITY SERVICE IS NECESSARY, THE CONTRACTOR SHALL GIVE AT LEAST ONE DAY NOTICE TO CUSTOMERS INVOLVED AND SHALL USE ALL HIS RESOURCES TO MINIMIZE INTERRUPTION.
- ALL DISTURBED AREAS SHALL BE GRADED TO PROVIDE POSITIVE DRAINAGE. CULVERTS, FIELD TILES AND OTHER DRAINAGE FACILITIES DAMAGED DURING CONSTRUCTION SHALL BE REPLACED BY CONTRACTOR AT NO ADDITIONAL COST TO THE VILLAGE.
- ANY PERMANENT SURFACE, STREET, DRIVEWAY, OR SIDEWALK DAMAGE BY CONTRACTOR SHALL BE REPAIRED BY CONTRACTOR AT HIS EXPENSE.
- SIDEWALKS ARE 5 FEET IN WIDTH UNLESS OTHERWISE SHOWN ON PLANS.

PORTLAND CEMENT CONCRETE SIDEWALK 5"

STATION TO STATION	SQUARE FOOT
	0+11 - 0+27
0+52 - 1+41	467
1+54 - 2+48	462
2+69 - 3+45	381
3+55 - 4+97	709
5+10 - 6+07	484
6+14 - 6+64	247
6+71 - 8+51	923
8+69 - 10+93	1337
11+16 - 12+11	706
12+45 - 12+73	165
13+11 - 15+81	1660
16+80 - 18+12	660
21+70 - 21+84	64
21+95 - 23+20	620
23+35 - 24+50	726
24+99 - 26+46	732
26+61 - 27+61	565
TOTAL=	10,968

SIDEWALK REMOVAL

STATION TO STATION	SIDEWALK REMOVAL
	SQUARE FOOT
0+73 - 1+35	321
1+54 - 2+22	330
2+30 - 2+42	85
2+42 - 2+48	28
2+59 - 3+45	377
3+55 - 4+97	645
5+10 - 6+07	419
6+14 - 6+64	242
6+71 - 8+48	820
8+71 - 12+10	2118
12+50 - 12+73	165
13+11 - 15+81	1682
15+93 - 15+98	31
18+58 - 19+40	332
21+00 - 21+38	260
21+38 - 23+16	680
23+42 - 26+41	1427
26+61 - 27+62	565
TOTAL=	10,527

SIGN SCHEDULE

STATION TO STATION	OFFSET	SQ. FT.
	0+29	5.0' - L
0+54	0.9' - R	8
12+72	1.2' - L	8
13+14	6.8' - R	8
TOTAL		32

BENCHMARK TABLE

STATION TO STATION	DESCRIPTION	ELEVATION	LOCATION
BM #1	RR SPIKE IN PP	610.03	CORNER OF PARK AND CHARLES
BM #2	RR SPIKE IN PP	607.87	305 CHARLES STREET
BM #3	RR SPIKE IN PP	611.45	NW CORNER OF HENRY ST
BM #4	RR SPIKE IN PP	613.57	SW CORNER OF COLUMBIA AND CHARLES
BM #5	RR SPIKE IN PP	615.30	SE CORNER OF BANK PARK LOT
BM #6	CENTER HB HYDRANT	617.13	SE CORNER OF POPLAR AND CHARLES
BM #7	NW HB HYDRANT	614.66	SW CORNER OF VINE AND CHARLES
BM #8	RR SPIKE IN PP	614.54	CHARLES AND NW RUNNING STREET
BM #9	RR SPIKE IN PP	616.48	ALLEY WEST OF 201 VINE ST
BM #10	RR SPIKE IN PP	617.87	CORNER OF VINE AND GEORGE
BM #11	SE HB HYDRANT	619.16	NE CORNER OF VINE AND JAMES

NO.	DESCRIPTION	BY	DATE	NO.	DESCRIPTION	BY	DATE
					DESIGNED		
					DRAWN	WFL	07/29/14
				A2	REVISED PER IDOT MARKUPS	WFL	02/01/16
				A1	REVISED SET	SLL	8/26/15

VILLAGE OF BEECHER CITY
EFFINGHAM COUNTY, IL
SAFE ROUTES TO SCHOOL
NOTES, QUANTITIES AND SCHEDULES



JOHN H. CRAWFORD & ASSOCIATES, P.C.
CIVIL ENGINEERS, LAND SURVEYORS
201 SOUTH DIVISION STREET, CARTERSVILLE, ILLINOIS 62918
PHONE (618) 985-8370 FAX (618) 985-4592
PROFESSIONAL DESIGN FIRM # 184-002885

SHEET NO.	
2	
ISSUE	DATE
A2	02/01/16



NO.	DESCRIPTION	BY	DATE	NO.	DESCRIPTION	BY	DATE	NO.	DESCRIPTION	BY	DATE
									DESIGNED		
									DRAWN	WFL	07/29/14
				A2	REVISED PER IDOT MARKUPS	WFL	02/01/16		CHECKED	RLP	07/29/14
				A1	REVISED SET	SLL	8/26/15				

VILLAGE OF BEECHER CITY
EFFINGHAM COUNTY, ILLINOIS
SAFE ROUTES TO SCHOOL
GENERAL LAYOUT



JOHN H. CRAWFORD & ASSOCIATES, P.C.
 CIVIL ENGINEERS, LAND SURVEYORS
 201 SOUTH DIVISION STREET, CARTERSVILLE, ILLINOIS 62918
 PHONE (618) 985-6370 FAX (618) 985-4692
 PROFESSIONAL DESIGN FIRM # 184-002885

SHEET NO.	
3	
ISSUE	DATE
A2	02/01/16

K:\land survey\effingham\Beecher City\SAFE ROUTES TO SCHOOL\2016\160101.dwg, 1/16/16 10:11:11 AM

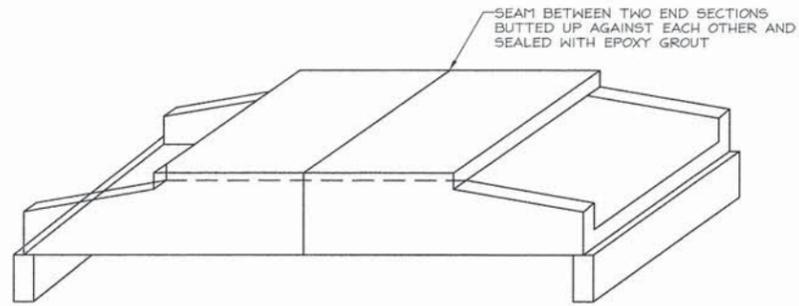

BOX CULVERT END SECTIONS
ANGLED DETAIL VIEW

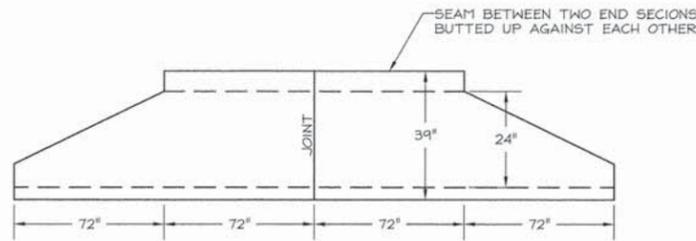

BOX CULVERT END SECTIONS
SIDE VIEW

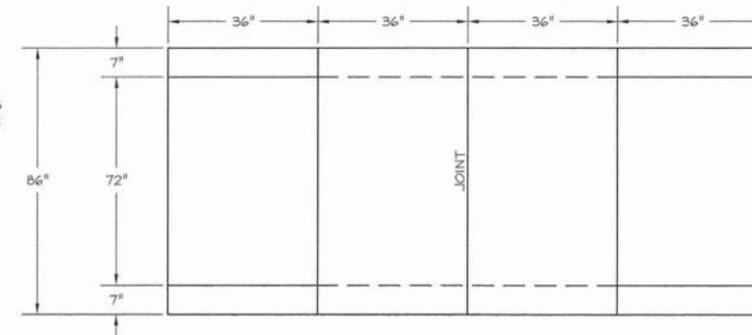

BOX CULVERT END SECTIONS
TYPICAL SECTION TOP VIEW

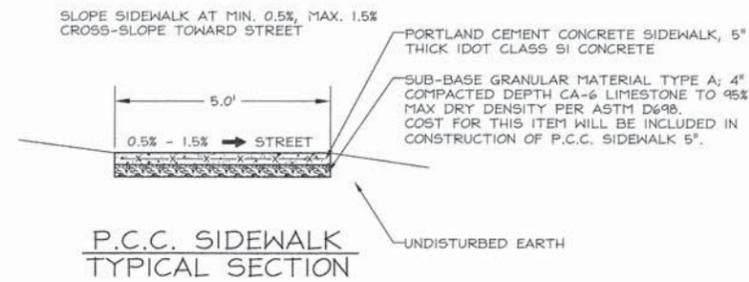

P.C.C. SIDEWALK
TYPICAL SECTION

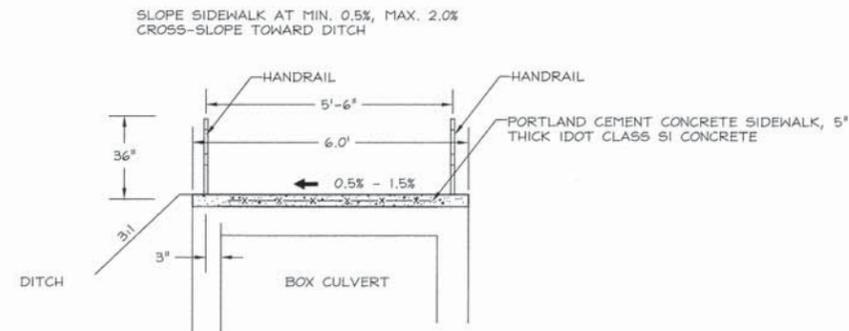

P.C.C. SIDEWALK
TYPICAL SECTION
(WITH HANDRAIL DETAIL)

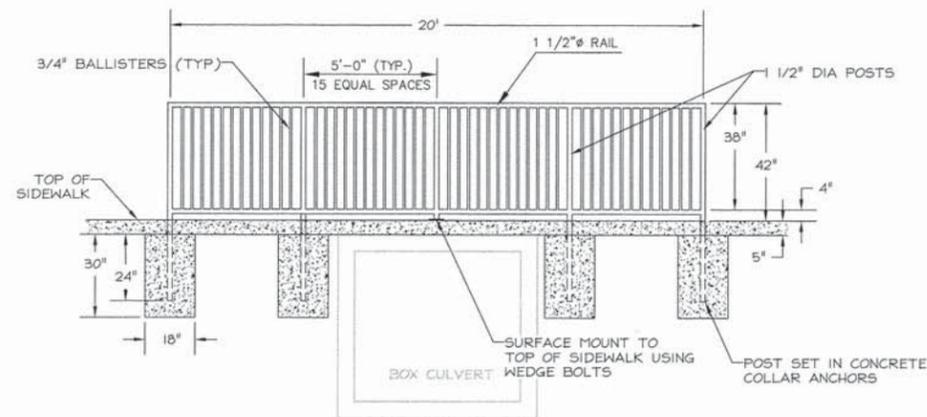

HANDRAIL DETAIL

NO.	DESCRIPTION	BY	DATE	NO.	DESCRIPTION	BY	DATE	DESIGNED	BY	DATE
								DRAWN	WFL	07/29/14
				A2	REVISED PER IDOT MARKUPS	WFL	02/01/16	CHECKED	RLP	07/29/14
				A1	REVISED SET	SLL	8/26/15			

VILLAGE OF BEECHER CITY
EFFINGHAM COUNTY, IL
SAFE ROUTES TO SCHOOL
DETAILS



JOHN H. CRAWFORD & ASSOCIATES, P.C.
CIVIL ENGINEERS, LAND SURVEYORS
201 SOUTH DIVISION STREET, CARTERVILLE, ILLINOIS 62918
PHONE (618) 985-6370 FAX (618) 985-4692
PROFESSIONAL DESIGN FIRM # 164-002885

SHEET NO.	
4	
ISSUE	DATE
A2	02/01/16

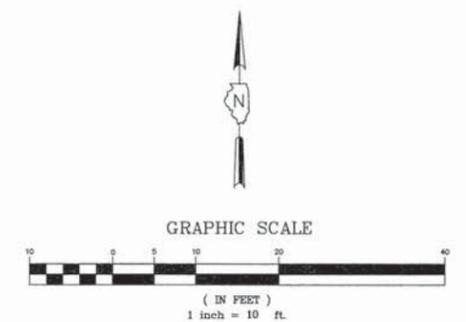
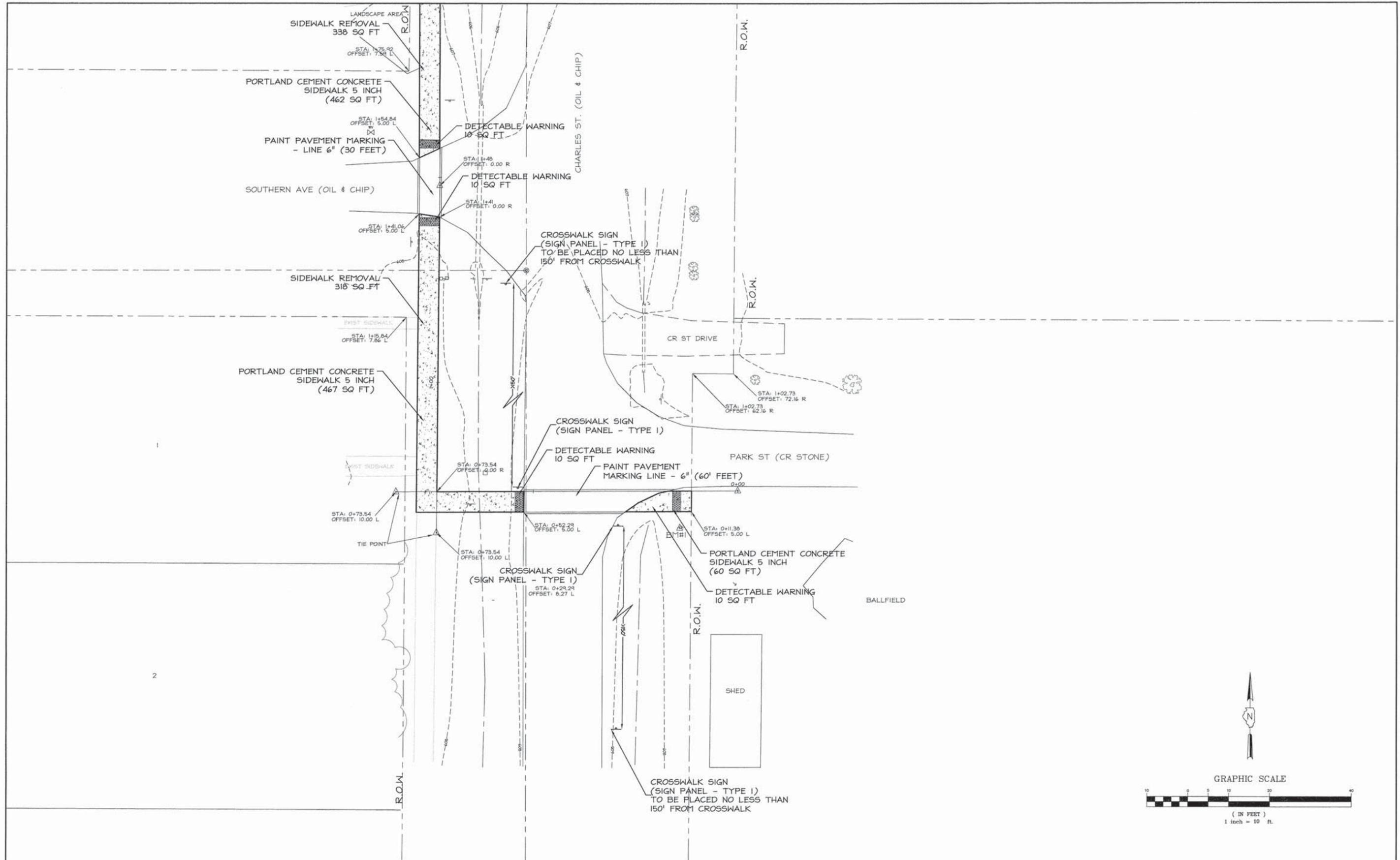

NO.	DESCRIPTION	BY	DATE	NO.	DESCRIPTION	BY	DATE	DESIGNED	BY	DATE
								DRAWN	WFL	07/29/14
				A2	REVISED PER IDOT MARKUPS	WFL	02/01/16	CHECKED	RLP	07/29/14
				A1	REVISED SET	SLL	8/26/15			

VILLAGE OF BEECHER CITY
EFFINGHAM COUNTY, IL
SAFE ROUTES TO SCHOOL
PLAN SHEET

JOHN H. CRAWFORD & ASSOCIATES, P.C.
CIVIL ENGINEERS, LAND SURVEYORS
201 SOUTH DIVISION STREET, CARTERSVILLE, ILLINOIS 62918
PHONE (618) 985-4370 FAX (618) 985-4692
PROFESSIONAL DESIGN FIRM # 184-002885

SHEET NO.	
5	
ISSUE	DATE
A2	02/01/16

A:\Work\Projects\City\Beecher\Beecher_School_Safe_Routes_Plan_Sheet.dwg - 02/01/16 11:30:21 AM

c:\projects\eng\Beecher_City\dwg\SSR\PLAN_SHEETS\FEBRUARY_2016.dwg, 4/5/2016 7:37:31 AM

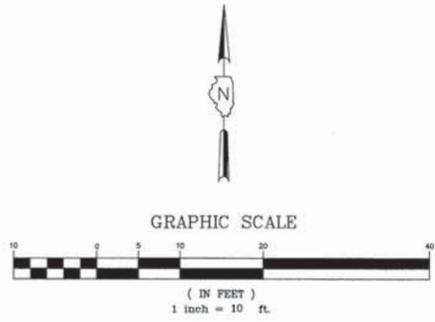
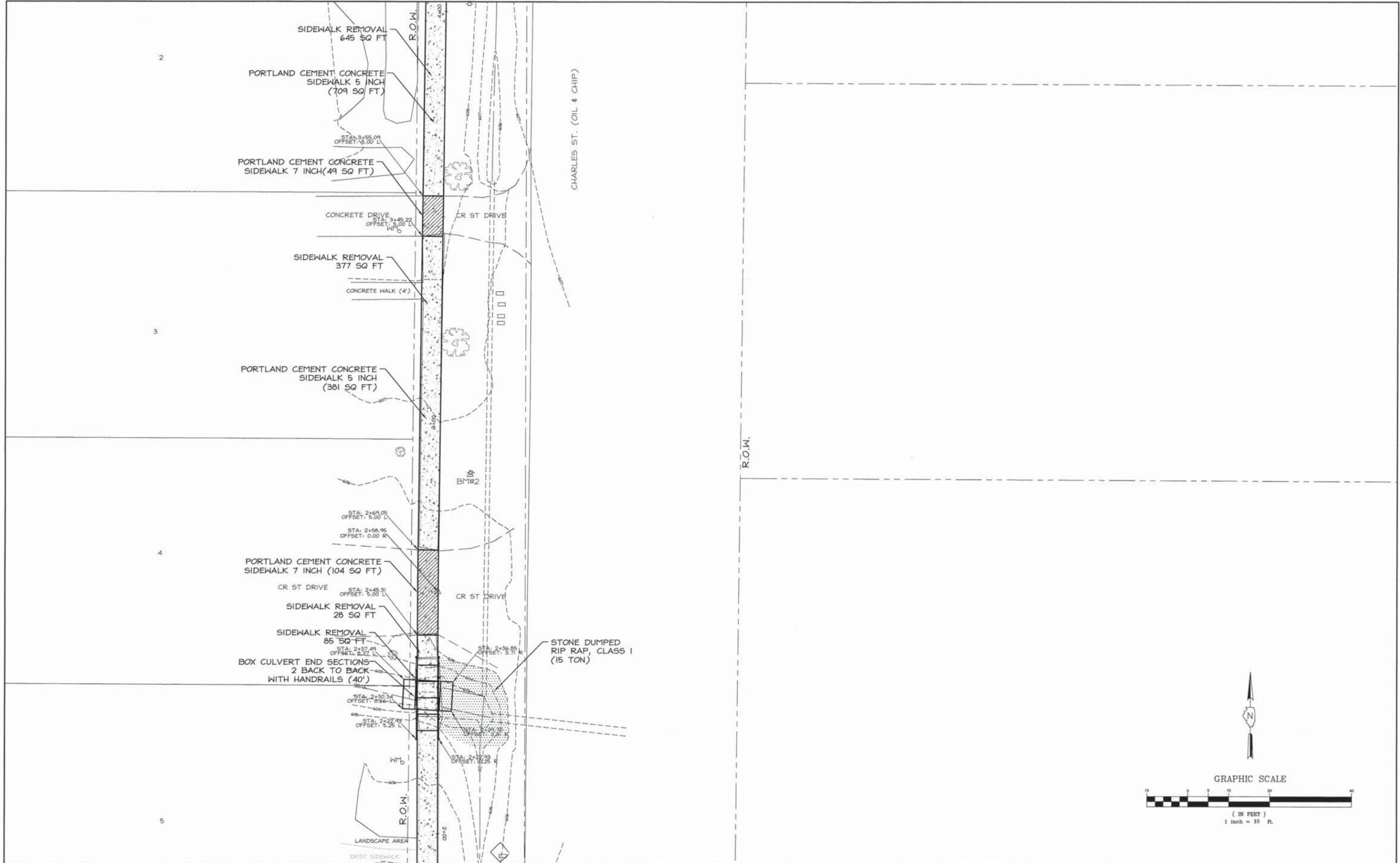

NO.	DESCRIPTION	BY	DATE	NO.	DESCRIPTION	BY	DATE
					DESIGNED		
					DRAWN	WFL	07/29/14
				A2	REVISED PER IDOT MARKUPS	WFL	02/01/16
				A1	REVISED SET	SLL	8/26/15

VILLAGE OF BEECHER CITY
EFFINGHAM COUNTY, IL
SAFE ROUTES TO SCHOOL
PLAN SHEET

JOHN H. CRAWFORD & ASSOCIATES, P.C.
CIVIL ENGINEERS, LAND SURVEYORS
201 SOUTH DIVISION STREET, CARTERSVILLE, ILLINOIS 62916
PHONE (618) 985-6370 FAX (618) 985-4692
PROFESSIONAL DESIGN FIRM # 184-002885

SHEET NO.	
6	
ISSUE	DATE
A2	02/01/16

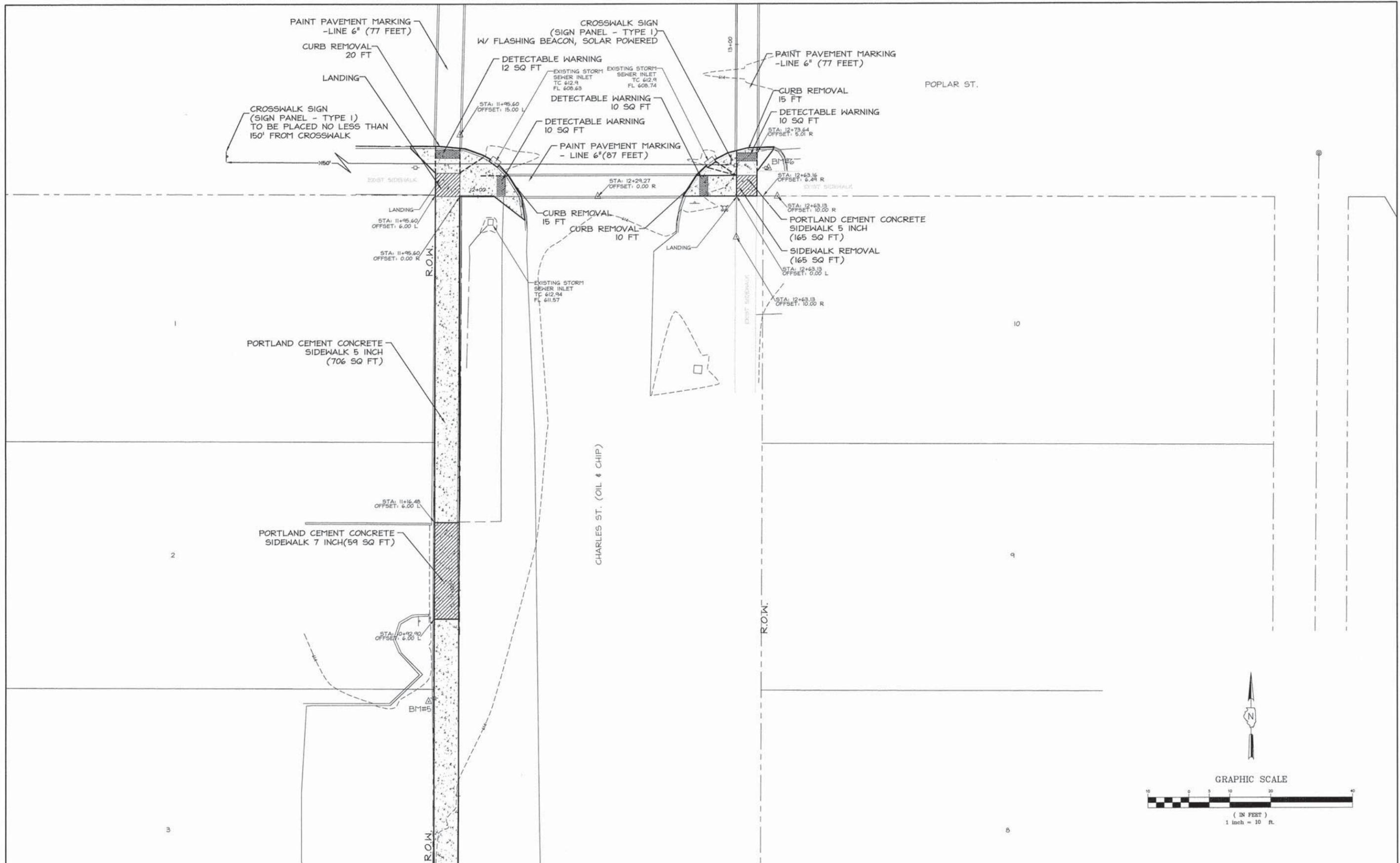

NO.	DESCRIPTION	BY	DATE	NO.	DESCRIPTION	BY	DATE	NO.	DESCRIPTION	BY	DATE
									DESIGNED		
									DRAWN	WFL	07/29/14
				A2	REVISED PER IDOT MARKUPS	WFL	02/01/16		CHECKED	RLP	07/29/14
				A1	REVISED SET	SLL	8/26/15				

VILLAGE OF BEECHER CITY
EFFINGHAM COUNTY, IL
SAFE ROUTES TO SCHOOL
PLAN SHEET

JOHN H. CRAWFORD & ASSOCIATES, P.C.
CIVIL ENGINEERS, LAND SURVEYORS
201 SOUTH DIVISION STREET, CARTERSVILLE, ILLINOIS 62918
PHONE (618) 985-6370 FAX (618) 985-4692
PROFESSIONAL DESIGN FIRM # 184-002885

SHEET NO.	
10	
ISSUE	DATE
A2	02/01/16

A:\Users\jgustafson\Documents\Projects\2016\Safe Routes to School\2016_SRTS_Plan_Sheet_10.dwg 1/15/2016 1:42:33 PM

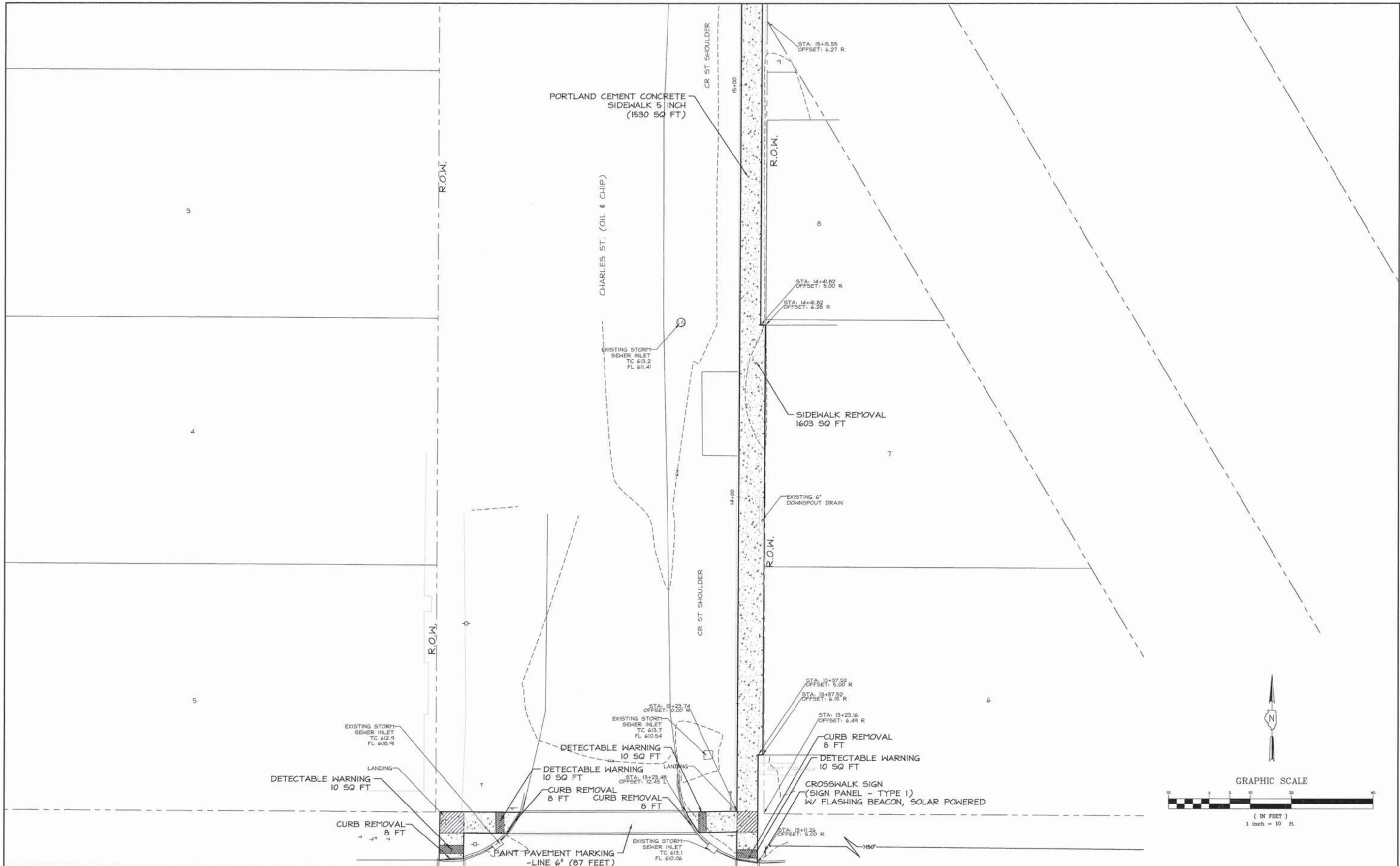

NO.	DESCRIPTION	BY	DATE	NO.	DESCRIPTION	BY	DATE	NO.	DESCRIPTION	BY	DATE
									DESIGNED		
									DRAWN	WFL	07/29/14
				A2	REVISED PER IDOT MARKUPS	WFL	02/01/16		CHECKED	RLP	07/29/14
				A1	REVISED SET	SLL	8/26/15				

VILLAGE OF BEECHER CITY
EFFINGHAM COUNTY, IL
SAFE ROUTES TO SCHOOL
PLAN SHEET

JOHN H. CRAWFORD & ASSOCIATES, P.C.
 CIVIL ENGINEERS, LAND SURVEYORS
 201 SOUTH DIVISION STREET, CARTERSVILLE, ILLINOIS 62918
 PHONE (618) 985-6370 FAX (618) 985-4692
 PROFESSIONAL DESIGN FIRM # 184-002885

SHEET NO.	
11	
ISSUE	DATE
A2	02/01/16

A:\Users\jmc\p01\proj\150000000\150000000.dwg SHEET 11 OF 11 2/1/16 1:41:35 PM

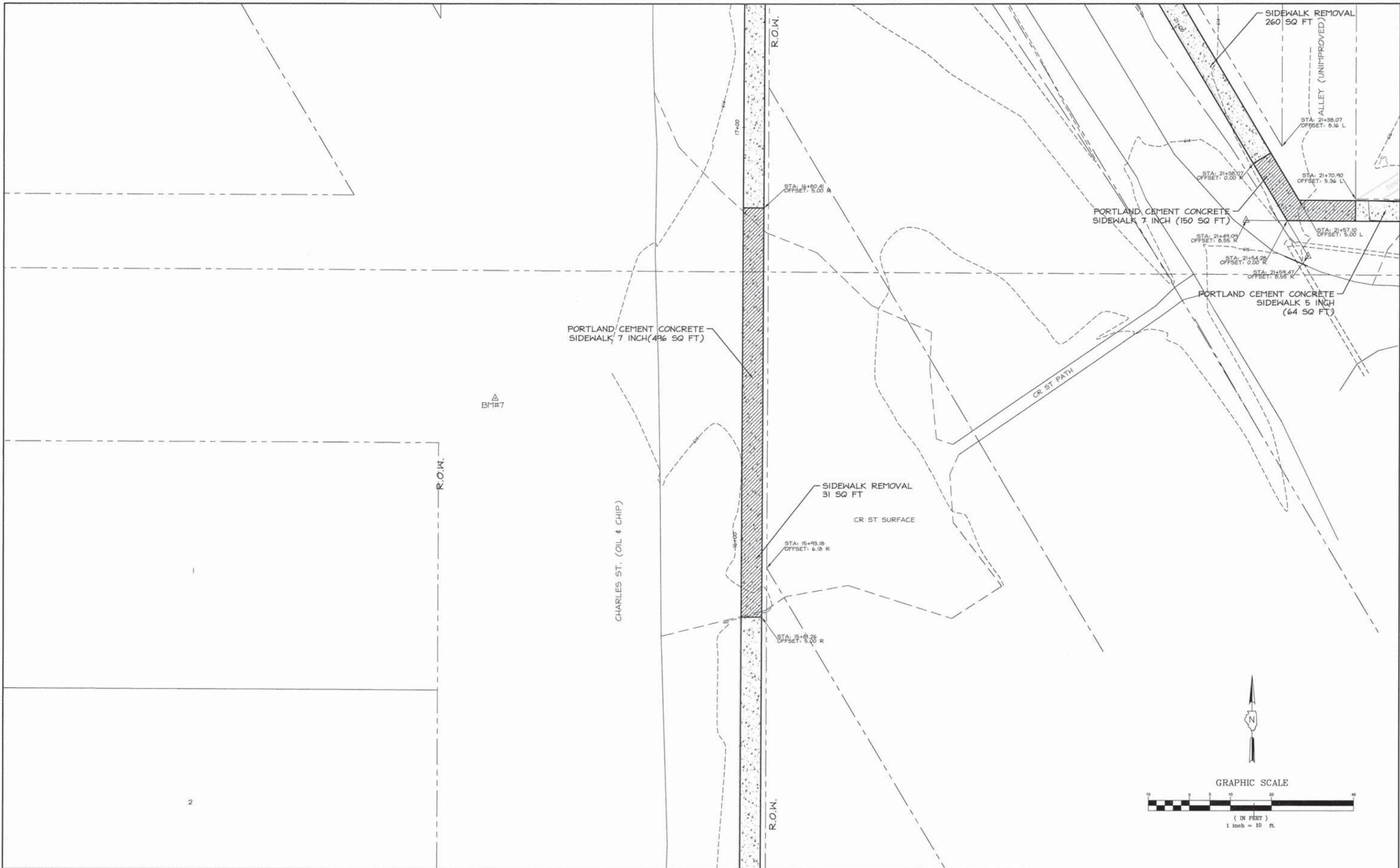

NO.	DESCRIPTION	BY	DATE	NO.	DESCRIPTION	BY	DATE
					DESIGNED		
					DRAWN	WFL	07/29/14
				A2	REVISED PER IDOT MARKUPS	WFL	02/01/16
				A1	REVISED SET	SLL	8/26/15

VILLAGE OF BEECHER CITY
EFFINGHAM COUNTY, IL
SAFE ROUTES TO SCHOOL
PLAN SHEET

JOHN H. CRAWFORD & ASSOCIATES, P.C.
CIVIL ENGINEERS, LAND SURVEYORS
201 SOUTH DIVISION STREET, CARTERSVILLE, ILLINOIS 62918
PHONE (618) 985-6370 FAX (618) 985-4692
PROFESSIONAL DESIGN FIRM # 184-002885

SHEET NO.	
12	
ISSUE	DATE
A2	02/01/16

K:\Users\jrcrawford\Documents\2015\SAFE ROUTES TO SCHOOL\2015 SAFE ROUTES TO SCHOOL - 2015\2015 SAFE ROUTES TO SCHOOL - 2015.dwg

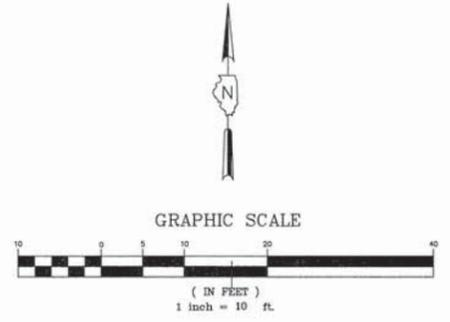
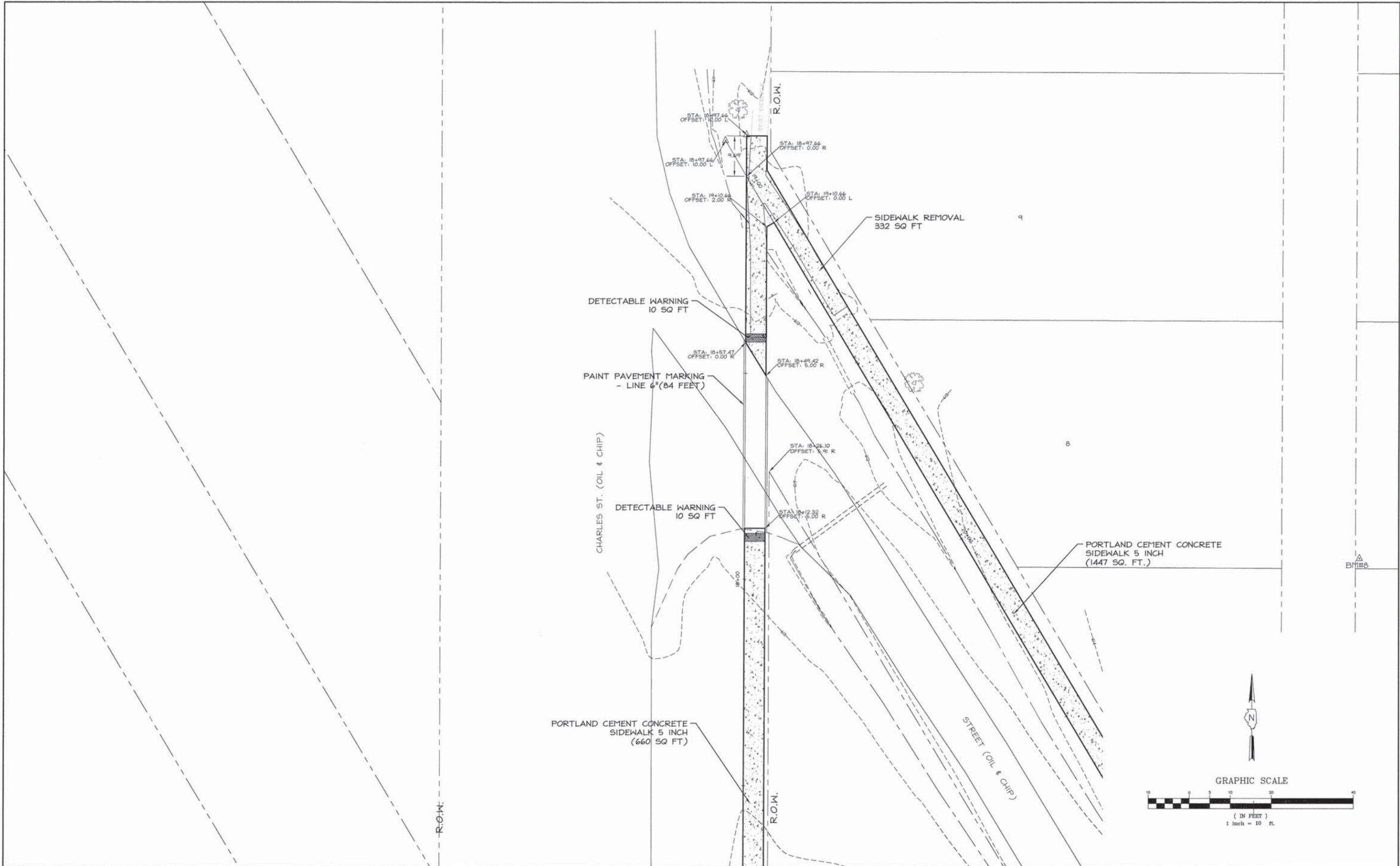

NO.	DESCRIPTION	BY	DATE	NO.	DESCRIPTION	BY	DATE
					DESIGNED		
					DRAWN	WFL	07/29/14
				A2	REVISED PER IDOT MARKUPS	WFL	02/01/16
				A1	REVISED SET	SLL	8/26/15

VILLAGE OF BEECHER CITY
EFFINGHAM COUNTY, IL
SAFE ROUTES TO SCHOOL
PLAN SHEET



JOHN H. CRAWFORD & ASSOCIATES, P.C.
CIVIL ENGINEERS, LAND SURVEYORS
201 SOUTH DIVISION STREET, CARTERSVILLE, ILLINOIS 62918
PHONE (618) 985-6370 FAX (618) 985-4692
PROFESSIONAL DESIGN FIRM # 184-002885

SHEET NO.	
13	
ISSUE	DATE
A2	02/01/16

C:\Users\jrcrawford\Documents\2015\SAFE ROUTES TO SCHOOL\2015\SAFE ROUTES TO SCHOOL\SAFE ROUTES TO SCHOOL.DWG

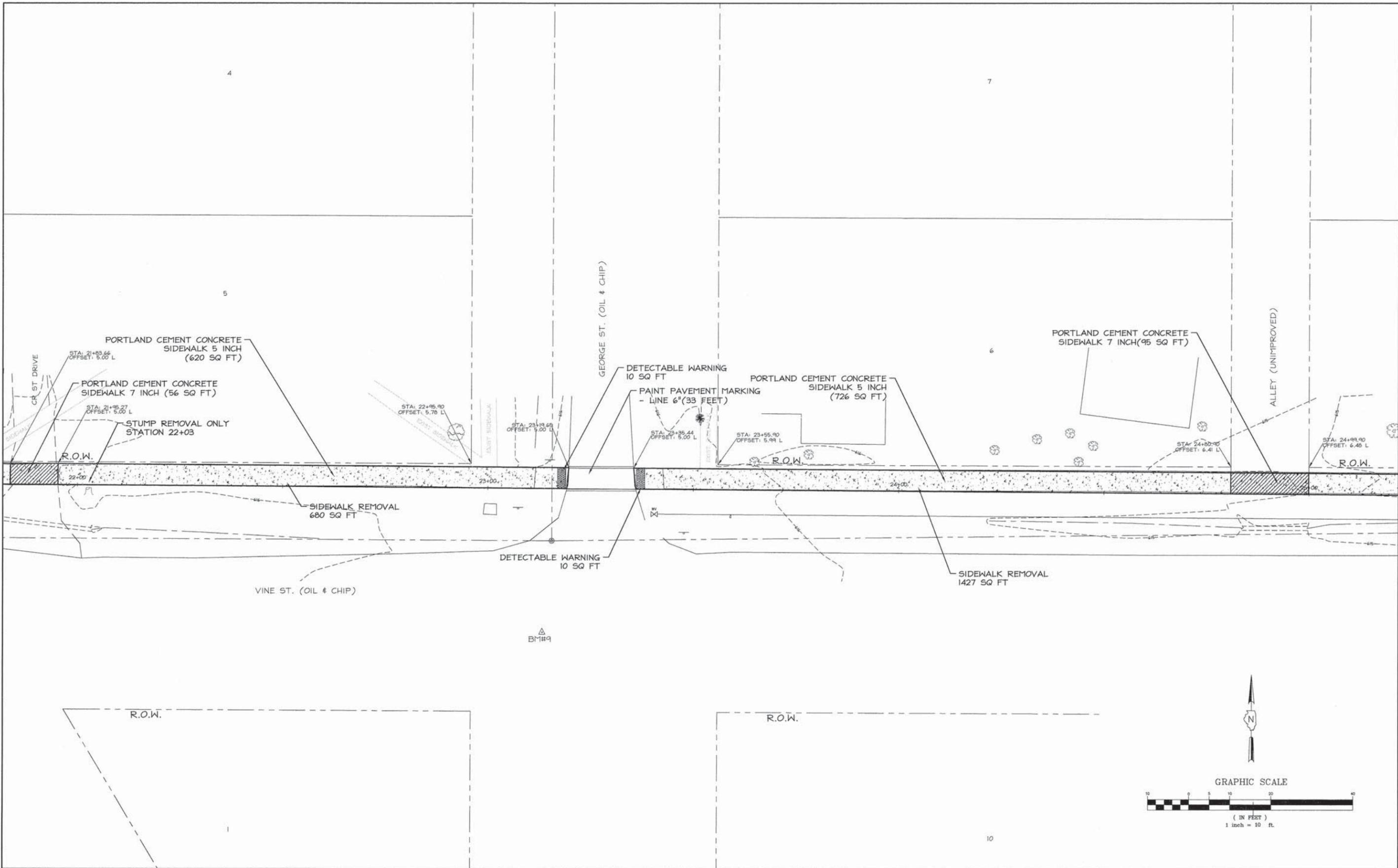

NO.	DESCRIPTION	BY	DATE	NO.	DESCRIPTION	BY	DATE	DESIGNED	BY	DATE
								DRAWN	WFL	07/29/14
				A2	REVISED PER IDOT MARKUPS	WFL	02/01/16	CHECKED	RLP	07/29/14
				A1	REVISED SET	SLL	8/26/15			

VILLAGE OF BEECHER CITY
EFFINGHAM COUNTY, IL
SAFE ROUTES TO SCHOOL
PLAN SHEET



JOHN H. CRAWFORD & ASSOCIATES, P.C.
CIVIL ENGINEERS, LAND SURVEYORS
201 SOUTH DIVISION STREET, CARTERVILLE, ILLINOIS 62918
PHONE (618) 985-6370 FAX (618) 985-4692
PROFESSIONAL DESIGN FIRM # 184-002885

SHEET NO.	
14	
ISSUE	DATE
A2	02/01/16

P:\Users\jrcrawford\My Documents\Projects\Beecher City\Safe Routes to School\Beecher City Safe Routes to School Plan Sheet.dwg, 2/1/2016, 1:43:08 PM

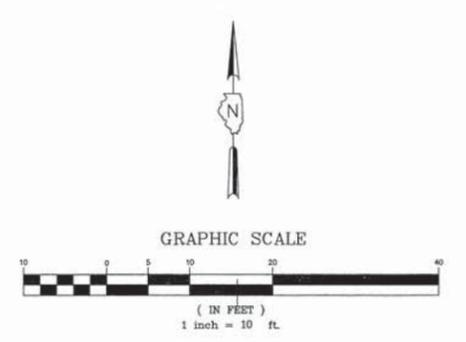
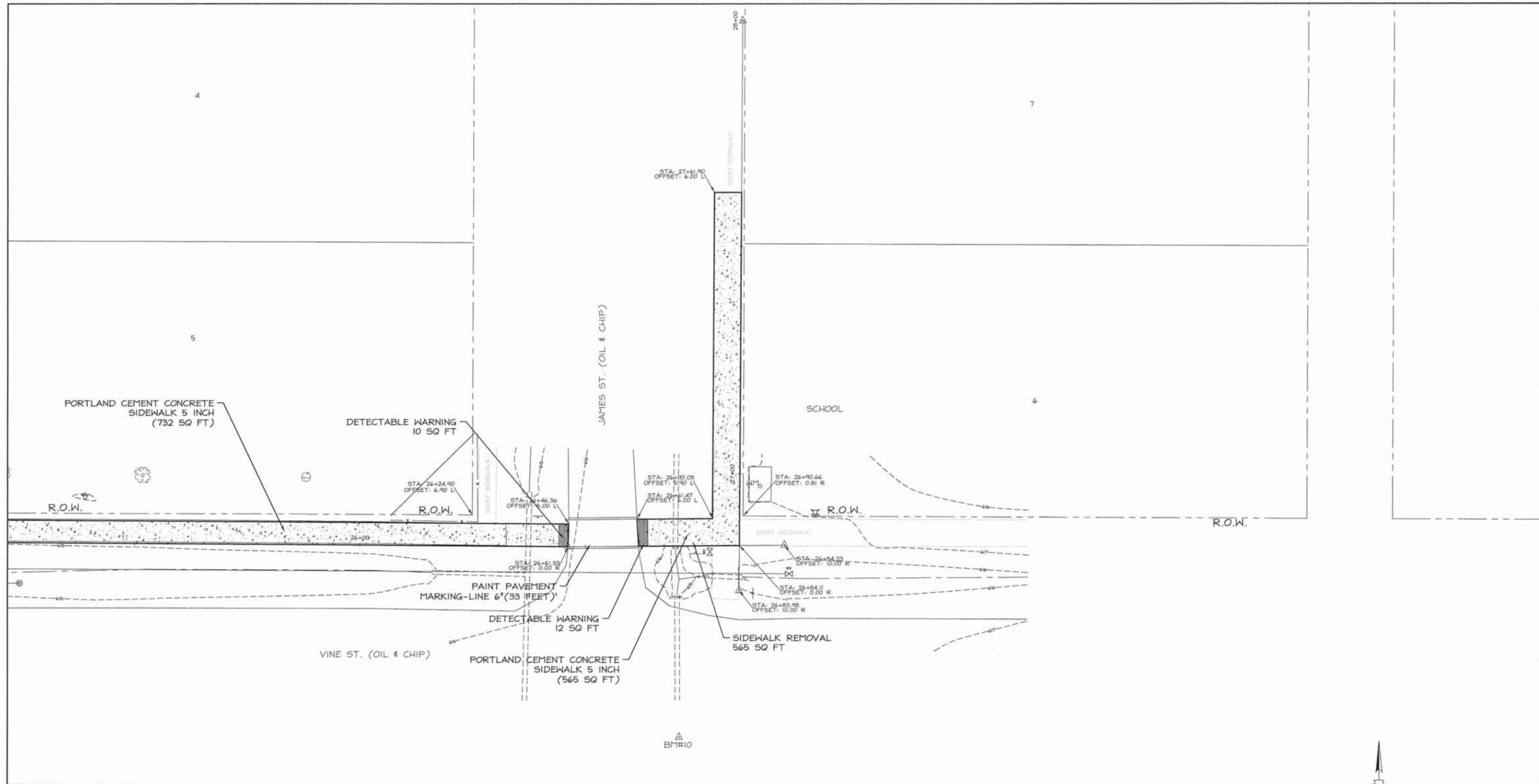

NO.	DESCRIPTION	BY	DATE	NO.	DESCRIPTION	BY	DATE	NO.	DESCRIPTION	BY	DATE
									DESIGNED		
									DRAWN	WFL	07/29/14
				A2	REVISED PER IDOT MARKUPS	WFL	02/01/16		CHECKED	RLP	07/29/14
				A1	REVISED SET	SLL	8/26/15				

VILLAGE OF BEECHER CITY
EFFINGHAM COUNTY, IL
SAFE ROUTES TO SCHOOL
PLAN SHEET

JOHN H. CRAWFORD & ASSOCIATES, P.C.
CIVIL ENGINEERS, LAND SURVEYORS
201 SOUTH DIVISION STREET, CARTERSVILLE, ILLINOIS 62918
PHONE (618) 985-6370 FAX (618) 985-4692
PROFESSIONAL DESIGN FIRM # 184-002885

SHEET NO.	
15	
ISSUE	DATE
A2	02/01/16

K:\Users\jrcrawford\Documents\2015\15-001\15-001.dwg 1/21/2015 10:51:44 AM

