

F.A.U. RTE.	SECTION	COUNTY	TOTAL SHEETS	SHEET NO.
3537	3264 RS-7	COOK	22	1
FED. ROAD DIST. NO.	ILLINOIS	CONTRACT NO. 60161		

STATE OF ILLINOIS  
DEPARTMENT OF TRANSPORTATION  
DIVISION OF HIGHWAYS

**PROPOSED  
HIGHWAY PLANS**

F.A.U. ROUTE 3537: LAKE ST.  
IL 171 (1ST AVE.) TO IL 43 (HARLEM AVE.)  
SECTION: 3264 RS-7  
RESURFACING  
COOK COUNTY  
C-91-085-10

FOR INDEX OF SHEETS, SEE SHEET NO. 2

THE IMPROVEMENT IS LOCATED IN  
THE VILLAGE OF RIVER FOREST

D-91-085-10

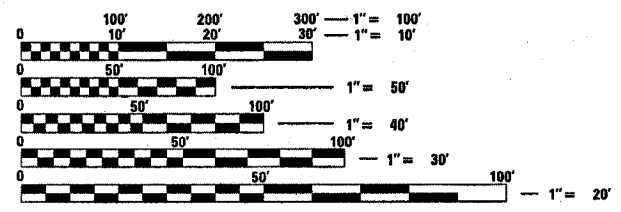

FULL SIZE PLANS HAVE BEEN PREPARED USING STANDARD ENGINEERING SCALES. REDUCED SIZED PLANS WILL NOT CONFORM TO STANDARD SCALES. IN MAKING MEASUREMENTS ON REDUCED PLANS, THE ABOVE SCALES MAY BE USED.

J.U.L.I.E.  
JOINT UTILITY LOCATION INFORMATION FOR EXCAVATION  
1-800-892-0123  
OR 811

IMPROVEMENT  
END: STA. 90+72

IMPROVEMENT  
BEGINS: STA. 13+89

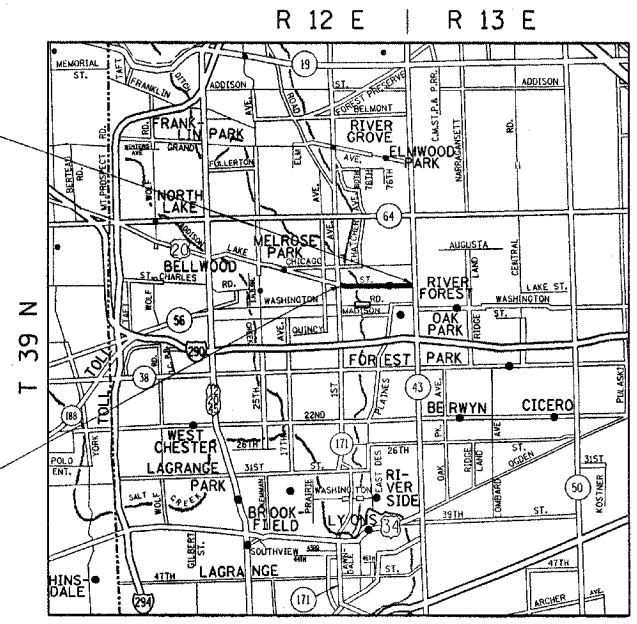

RIVER FOREST TOWNSHIP



**TRAFFIC DATA**

2006 ADT = 14,600  
POSTED SPEED LIMIT = 30 MPH

GROSS AND NET LENGTH OF IMPROVEMENT = 7683 FEET = 1.46 MILES

PROJECT ENGINEER: KARI SMITH (847) 705-4437  
PROJECT MANAGER: KEN ENG

CONTRACT NO. 60161

STATE OF ILLINOIS  
DEPARTMENT OF TRANSPORTATION  
DIVISION OF HIGHWAYS

SUBMITTED March 22 2010

Doree Clark  
DEPUTY DIRECTOR OF HIGHWAYS, REGION ENGINEER

May 7 2010  
Scott E. Stitt, P.E.  
ENGINEER OF DESIGN AND ENVIRONMENT

May 7 2010  
Christine M. Road/er  
DIRECTOR OF HIGHWAYS, CHIEF ENGINEER

**PRINTED BY THE AUTHORITY  
OF THE STATE OF ILLINOIS**

INDEX OF SHEETS

<u>SHEET NO.</u>	<u>DESCRIPTION</u>
1	TITLE SHEET
2	INDEX OF SHEETS, STATE STANDARDS & GENERAL NOTES
3	SUMMARY OF QUANTITIES
4	EXISTING AND PROPOSED TYPICAL SECTION
5-7	ROADWAY AND PAVEMENT MARKING PLANS
8-9	DETECTOR LOOP REPLACEMENT SHEETS
10	DETAILS FOR FRAMES AND LIDS ADJUSTMENT WITH MILLING
11	PAVEMENT PATCHING FOR HMA SURFACED PAVEMENT
12	CURB OR CURB AND GUTTER REMOVAL AND REPLACEMENT
13	BUTT JOINT AND HMA TAPER
14	HMA TAPER AT EDGE OF P.C.C. PAVEMENT
15	TRAFFIC CONTROL AND PROTECTION FOR SIDE ROADS, INTERSECTIONS, AND DRIVEWAYS
16	TYPICAL APPLICATIONS RAISED REFLECTIVE PAVEMENT MARKERS (SNOW-PLOW RESISTANT)
17	DISTRICT ONE TYPICAL PAVEMENT MARKINGS
18	TRAFFIC CONTROL AND PROTECTION AT TURN BAYS (TO REMAIN OPEN TO TRAFFIC)
19	PAVEMENT MARKING LETTERS AND SYMBOLS FOR TRAFFIC STAGING
20	ARTERIAL INFORMATION SIGNING
21	STANDARD TRAFFIC SIGNAL DESIGN DETAILS
22	DETECTOR LOOP INSTALLATION DETAIL FOR ROADWAY RESURFACING

GENERAL NOTES

BEFORE STARTING ANY EXCAVATION, THE CONTRACTOR SHALL CALL "JULIE" AT (800) 892-0123 OR 811 FOR FIELD LOCATIONS OF BURIED ELECTRIC, TELEPHONE, AND GAS FACILITIES. (48 HOUR NOTIFICATION REQUIRED)

THE CONTRACTOR SHALL COORDINATE CONSTRUCTION ACTIVITIES WITH UTILITY COMPANIES AND THE VILLAGE OF RIVER FOREST.

THE CONTRACTOR WILL NOT BE ABLE TO SET UP A YARD OR FIELD OFFICE ON STATE PROPERTY WITHOUT THE WRITTEN PERMISSION OF THE DEPARTMENT.

BUTT JOINTS WILL BE INSTALLED AT THE ENDS OF RESURFACING (WHERE RESURFACING MEETS EXISTING PAVEMENT) IN ACCORDANCE WITH THE "BUTT JOINT AND HMA TAPER DETAILS" SHEET INCLUDED IN THE PLANS UNLESS OTHERWISE SPECIFIED.

THE RESIDENT ENGINEER SHALL CONTACT MS. PATRICE HARRIS, AREA TRAFFIC FIELD TECHNICIAN, AT (708) 597-9800 A MINIMUM OF 2 WEEKS PRIOR TO PLACEMENT OF FINAL PAVEMENT MARKINGS.

WHEN MILLED PAVEMENT IS OPEN TO TRAFFIC, THE MAXIMUM GRADE DIFFERENTIAL BETWEEN PASSES OF THE MILLING MACHINE SHALL NOT EXCEED 1/2 INCHES WHERE THE SPEED LIMIT IS 45 MPH OR LESS, AND 1 INCH WHERE THE SPEED LIMIT IS OVER 45 MPH. WITH WRITTEN APPROVAL FROM THE RESIDENT ENGINEER, A MAXIMUM GRADE DIFFERENTIAL OF 3 INCHES MAY BE ALLOWED IF THE EDGE OF THE MILLING IS SLOPED A MINIMUM OF 1:3 (V:H).

THE RESIDENT ENGINEER SHALL VERIFY LOCATIONS OF ALL EXISTING PAVEMENT MARKINGS PRIOR TO MILLING OR RESURFACING.

THE RESIDENT ENGINEER SHALL CONTACT THE TRAFFIC CONTROL SUPERVISOR AT (847) 705-4470 A MINIMUM OF 72 HOURS PRIOR TO THE INSTALLATION OF ANY TEMPORARY TRAFFIC CONTROL DEVICES.

LOCATIONS OF CLASS D PATCHING AND COMBINATION CURB AND GUTTER REMOVAL AND REPLACEMENT TO BE DETERMINED IN THE FIELD BY THE RESIDENT ENGINEER.

STATE STANDARDS

<u>STANDARD NO.</u>	<u>DESCRIPTION</u>
000001-05	TYPICAL SYMBOLS, ABBREVIATIONS AND PATTERNS
442201-03	CLASS C AND D PATCHES
604001-03	FRAME AND LID, TYPE 1
604086-02	FRAME AND GRATE, TYPE 23
604091-02	FRAME AND GRATE, TYPE 24
606001-04	COMBINATION CONCRETE CURB AND GUTTER
701301-03	TRAFFIC CONTROL & PROTECTION
701501-05	URBAN LANE CLOSURE, 2L, 2W
701606-06	URBAN LANE CLOSURE, MULTILANE, 2W WITH MOUNTABLE MEDIAN
701701-06	URBAN LANE CLOSURE, MULTILANE INTERSECTION
701901-01	TRAFFIC CONTROL DEVICES
780001-02	PAVEMENT MARKINGS
781001-03	PAVEMENT MARKINGS, RAISED REFLECTIVE, APPLICATIONS
886001-01	DETECTOR LOOP INSTALLATION
886006-01	DETECTION LOOPS, TYPICAL LAYOUT

FILE NAME =	USER NAME = rosierjm	DESIGNED J M ROSIERE	REVISED -	<b>STATE OF ILLINOIS DEPARTMENT OF TRANSPORTATION</b>	<b>LAKE ST. (IL 171 TO IL 43) INDEX OF SHEETS, STATE STANDARDS AND GENERAL NOTES</b>			F.A.U. RTE.	SECTION	COUNTY	TOTAL SHEETS	SHEET NO.
c:\pwwork\pwwid\rosierjm\d0159113\0168510-shr-plan.dgn	DRAWN J M ROSIERE	REVISED -			3537	3264 RS-7	COOK	22	2			
PLOT SCALE = 500000' / IN.	CHECKED -	REVISED -			CONTRACT NO. 60161							
PLOT DATE = 3/22/2010	DATE -	REVISED -			FED. ROAD DIST. NO. 1 ILLINOIS FED. AID PROJECT							
				SCALE: N/A	SHEET NO.	OF	SHEETS	STA.	TO STA.			

SUMMARY OF QUANTITIES			URBAN 100% STATE	CONSTRUCTION TYPE CODE					SUMMARY OF QUANTITIES			URBAN 100% STATE	CONSTRUCTION TYPE CODE				
CODE NO	ITEM	UNIT	TOTAL QUANTITIES	1000					CODE NO	ITEM	UNIT	TOTAL QUANTITIES	1000				
21101615	TOPSOIL FURNISH AND PLACE, 4"	SO YD	46	46					70300240	TEMPORARY PAVEMENT MARKING - LINE 6"	FOOT	5092	5092				
25200110	SODDING, SALT TOLERANT	SO YD	46	46					70300260	TEMPORARY PAVEMENT MARKING - LINE 12"	FOOT	1852	1852				
40600200	BITUMINOUS MATERIALS (PRIME COAT)	TON	32	32					70300280	TEMPORARY PAVEMENT MARKING - LINE 24"	FOOT	509	509				
40600300	AGGREGATE (PRIME COAT)	TON	161	161					70301000	WORK ZONE PAVEMENT MARKING REMOVAL	SO FT	1380	1380				
40600400	MIXTURE FOR CRACKS, JOINTS, AND FLANGEWAYS	TON	61	61					• 78000100	THERMOPLASTIC PAVEMENT MARKING - LETTERS AND SYMBOLS	SO FT	562	562				
40600826	POLYMERIZED LEVELING BINDER (MACHINE METHOD), IL-4.75, N50	TON	1426	1426					• 78000200	THERMOPLASTIC PAVEMENT MARKING - LINE 4"	FOOT	14718	14718				
40600895	CONSTRUCTING TEST STRIP	EACH	1	1					• 78000400	THERMOPLASTIC PAVEMENT MARKING - LINE 6"	FOOT	5092	5092				
40600982	HOT-MIX ASPHALT SURFACE REMOVAL - BUTT JOINT	SO YD	493	493					• 78000600	THERMOPLASTIC PAVEMENT MARKING - LINE 12"	FOOT	1852	1852				
40603340	HOT-MIX ASPHALT SURFACE COURSE, MIX "D", N70	TON	3363	3363					• 78000650	THERMOPLASTIC PAVEMENT MARKING - LINE 24"	FOOT	509	509				
42001300	PROTECTIVE COAT	SO YD	106	106					• 78100100	RAISED REFLECTIVE PAVEMENT MARKER	EACH	295	295				
44000155	HOT-MIX ASPHALT SURFACE REMOVAL, 1 1/2"	SO YD	5469	5469					78300200	RAISED REFLECTIVE PAVEMENT MARKER REMOVAL	EACH	215	215				
44000158	HOT-MIX ASPHALT SURFACE REMOVAL, 2 1/4"	SO YD	34558	34558					• 88600600	DETECTOR LOOP REPLACEMENT	FOOT	1282	1282				
44001700	COMBINATION CONCRETE CURB AND GUTTER REMOVAL AND REPLACEMENT	FOOT	465	465					X0322256	TEMPORARY INFORMATION SIGNING	SO FT	51.4	51.4				
44201789	CLASS D PATCHES, TYPE II, 12 INCH	SO YD	830	830					Z0018500	DRAINAGE STRUCTURES TO BE CLEANED	EACH	55	55				
44201794	CLASS D PATCHES, TYPE III, 12 INCH	SO YD	346	346					Z0048665	RAILROAD PROTECTIVE LIABILITY INSURANCE	L SUM	1	1				
44201796	CLASS D PATCHES, TYPE IV, 12 INCH	SO YD	208	208													
55039700	STORM SEWERS TO BE CLEANED	FOOT	700	700													
60300105	FRAMES AND GRATES TO BE ADJUSTED	EACH	24	24													
60300310	FRAMES AND LIDS TO BE ADJUSTED (SPECIAL)	EACH	143	143													
60404940	FRAMES AND GRATES, TYPE 23	EACH	2	2													
60404950	FRAMES AND GRATES, TYPE 24	EACH	1	1													
60406100	FRAMES AND LIDS, TYPE 1, CLOSED LID	EACH	3	3													
67000400	ENGINEER'S FIELD OFFICE, TYPE A	CAL MO	6	6													
67100100	MOBILIZATION	L SUM	1	1													
70102620	TRAFFIC CONTROL AND PROTECTION, STANDARD 701501	L SUM	1	1													
70102625	TRAFFIC CONTROL AND PROTECTION, STANDARD 701606	L SUM	1	1													
70102635	TRAFFIC CONTROL AND PROTECTION, STANDARD 701701	L SUM	1	1													
70300100	SHORT-TERM PAVEMENT MARKING	FOOT	4676	4676													
70300210	TEMPORARY PAVEMENT MARKING - LETTERS AND SYMBOLS	SO FT	562	562													
70300220	TEMPORARY PAVEMENT MARKING - LINE 4"	FOOT	14718	14718													

• DENOTES SPECIALTY ITEM

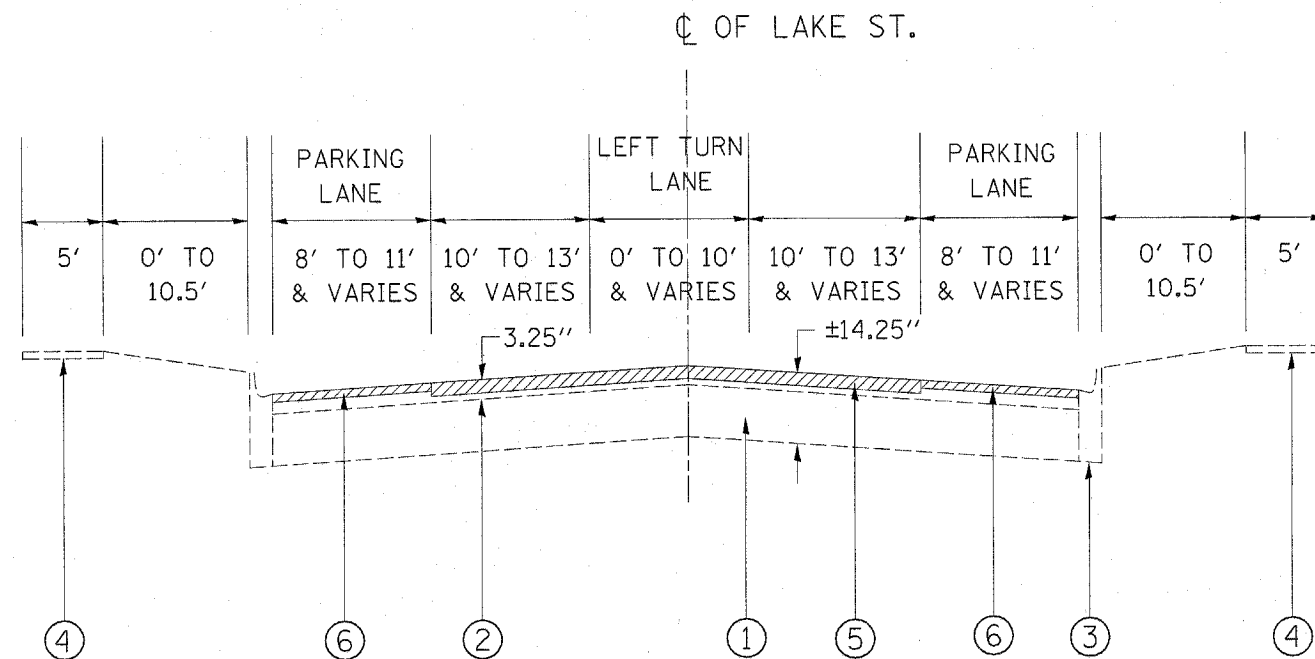

EXISTING TYPICAL SECTION  
LAKE ST.  
STA. 13+89 TO STA. 90+72

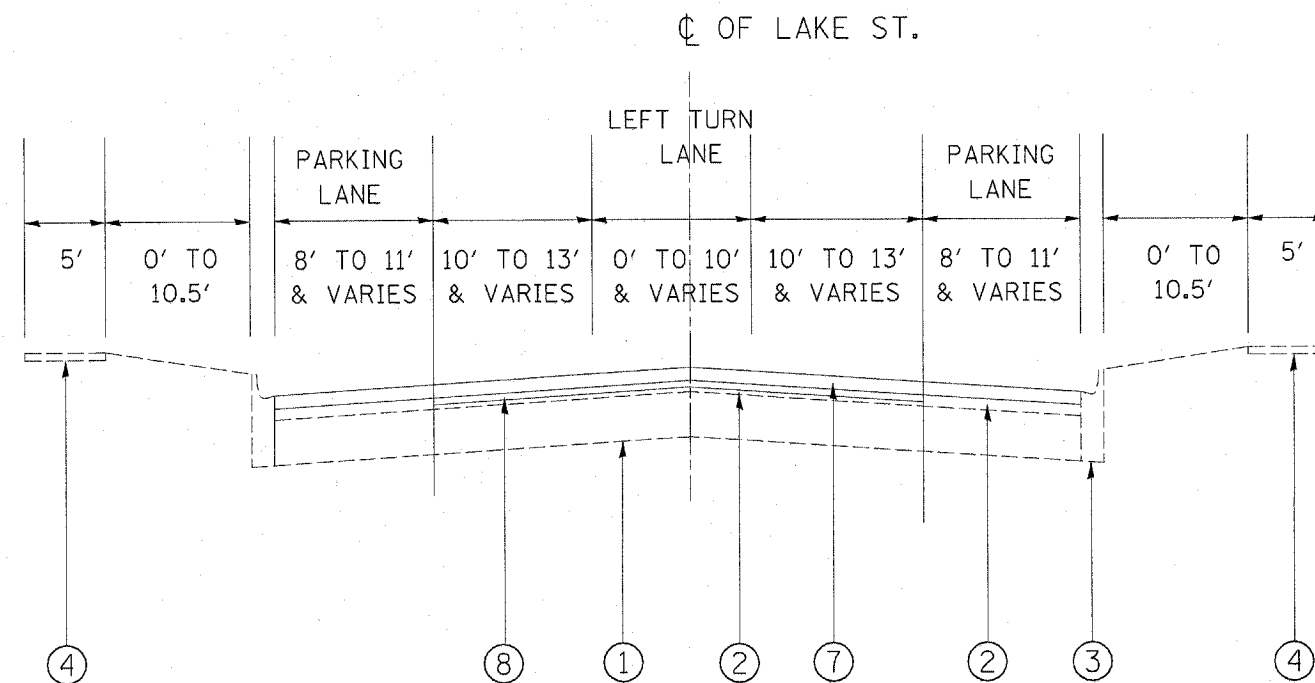

PROPOSED TYPICAL SECTION  
LAKE ST.  
STA. 13+89 TO STA. 90+72

**LEGEND**

- ① EXISTING H.M.A. BASE COURSE ±11"
- ② EXISTING H.M.A. SURFACE COURSE
- ③ EXISTING COMB. CONC. CURB & GUTTER
- ④ EXISTING P.C.C. SIDEWALK, 5".
- ⑤ PROPOSED H.M.A SURFACE COURSE REMOVAL, 2 1/4"
- ⑥ PROPOSED H.M.A SURFACE COURSE REMOVAL, 1 1/2"
- ⑦ PROPOSED H.M.A. SURFACE COURSE, MIX "D" N70, 1 1/2 "
- ⑧ PROPOSED POLYMERIZED LEV. BINDER (MM), IL-4.75, N50, 3/4 "

**HOT-MIX ASPHALT MIXTURE REQUIREMENTS**

	MIXTURE USE	AIR VOIDS (%)
ROADWAY	HOT-MIX ASPHALT SURFACE COURSE, MIX "D", N70 (IL 9.5 MM), 1 1/2 "	4% @ 70 GYR
	POLYMERIZED LEVELING BINDER COURSE (MM), IL-4.75, N50, 3/4"	4% @ 50 GYR
PATCHES	CLASS D PATCHES, (BINDER IL-19.0 MM), 12"	4% @ 70 GYR

THE UNIT WEIGHT USED TO CALCULATE ALL HOT-MIX ASPHALT SURFACE MIXTURE QUANTITIES IS 112 LBS/SY/IN.

THE "AC TYPE" FOR POLYMERIZED HMA MIXES SHALL BE "SBS/SBR PG 70-22" AND FOR NON-POLYMERIZED HMA THE "AC TYPE" SHALL BE "PG 64-22" UNLESS MODIFIED BY DISTRICT ONE SPECIAL PROVISIONS. FOR "PERCENT RAP" SEE DISTRICT ONE SPECIAL PROVISIONS.

**\* NOTES**

1. ROADWAY MILLING SHALL BE DONE PRIOR TO PAVEMENT PATCHING. SEE DISTRICT DETAIL BD-22.
2. PARKING LANE LOCATIONS SHOWN ON ROADWAY AND PAVEMENT MARKING PLANS.

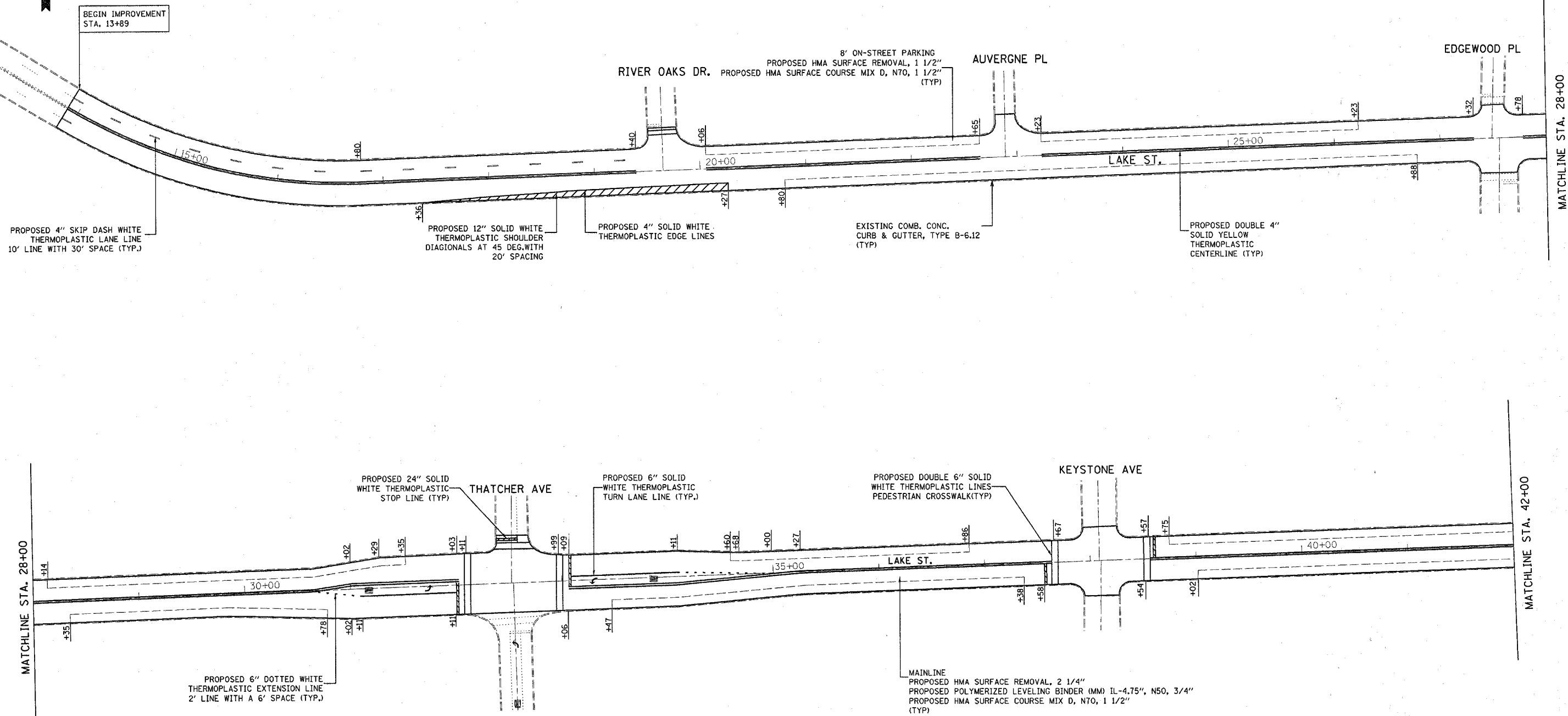

FILE NAME = c:\pwork\pwidot\rosierejm\0159113\0159510-shit-plan.dgn	USER NAME = rosier/jm	DESIGNED J M ROSIERE	REVISED -	<b>STATE OF ILLINOIS</b> <b>DEPARTMENT OF TRANSPORTATION</b>	<b>LAKE ST. (IL 171 TO IL 43)</b> <b>ROADWAY AND PAVEMENT MARKING PLANS</b>	F.A.U. RTE. 3537	SECTION 3264 RS-7	COUNTY COOK	TOTAL SHEETS 22	SHEET NO. 5			
	PLOT SCALE = 50,000' / IN.	CHECKED -	REVISED -			SCALE: 1" = 50'	SHEET NO. 1 OF 3 SHEETS	STA. 13+89 TO STA. 42+00	CONTRACT NO. 60161				
	PLOT DATE = 3/20/2010	DATE -	REVISED -			ILLINOIS FED. AID PROJECT							

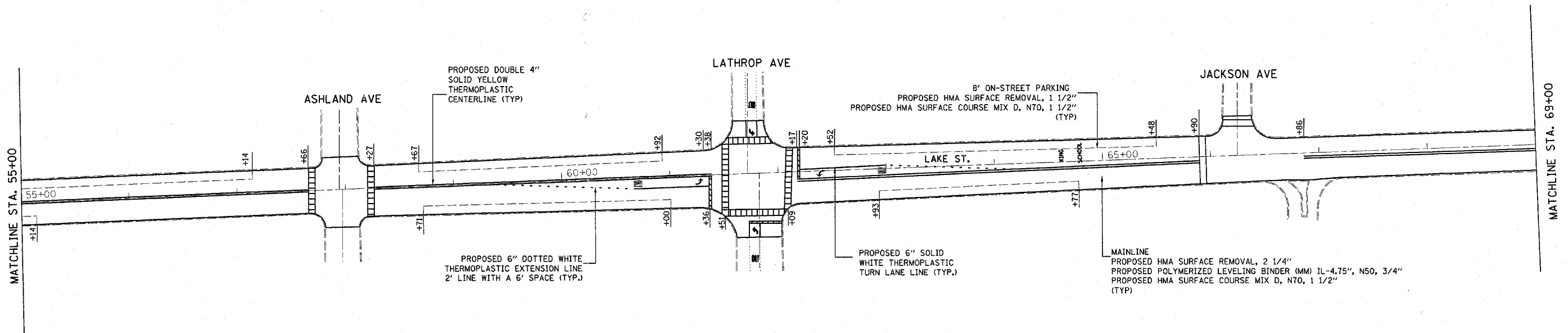
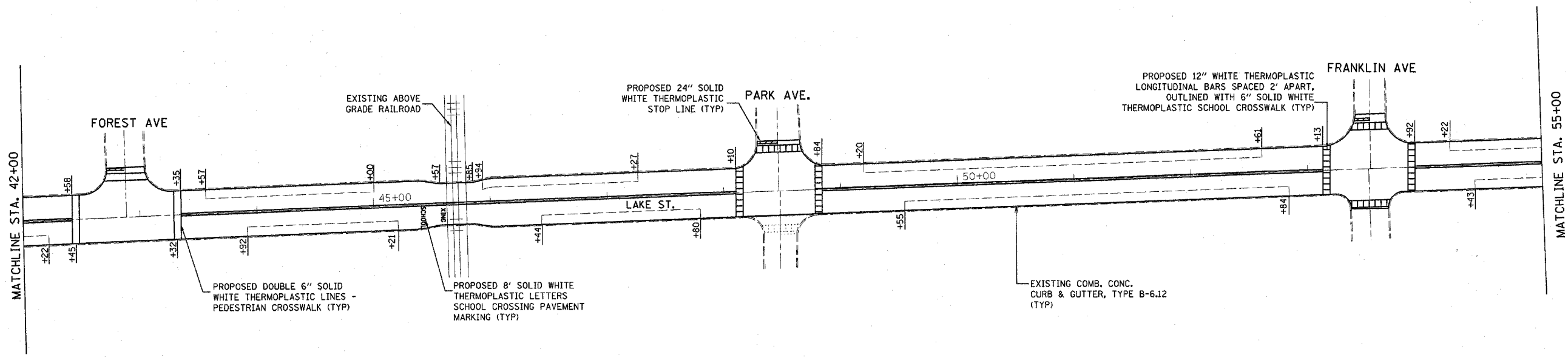

FILE NAME = c:\pwork\p\WIDOT\ROSIERE\JM\0159113\0103510-shit-plan.dgn	USER NAME = rosiere/jm	DESIGNED <i>J M ROSIERE</i>	REVISED -	<b>STATE OF ILLINOIS</b> <b>DEPARTMENT OF TRANSPORTATION</b>	<b>LAKE ST. (IL 171 TO IL 43)</b> <b>ROADWAY AND PAVEMENT MARKING PLANS</b>			F.A.U. RTE. 3537	SECTION 3264 RS-7	COUNTY COOK	TOTAL SHEETS 22	SHEET NO. 6
	PLOT SCALE = 50,0000' / IN.	CHECKED -	REVISED -		SCALE: 1" = 50'	SHEET NO. 2 OF 3 SHEETS	STA. 42+00 TO STA. 69+00	CONTRACT NO. 60161				
	PLOT DATE = 3/20/2010	DATE -	REVISED -					ILLINOIS FED. AID PROJECT				

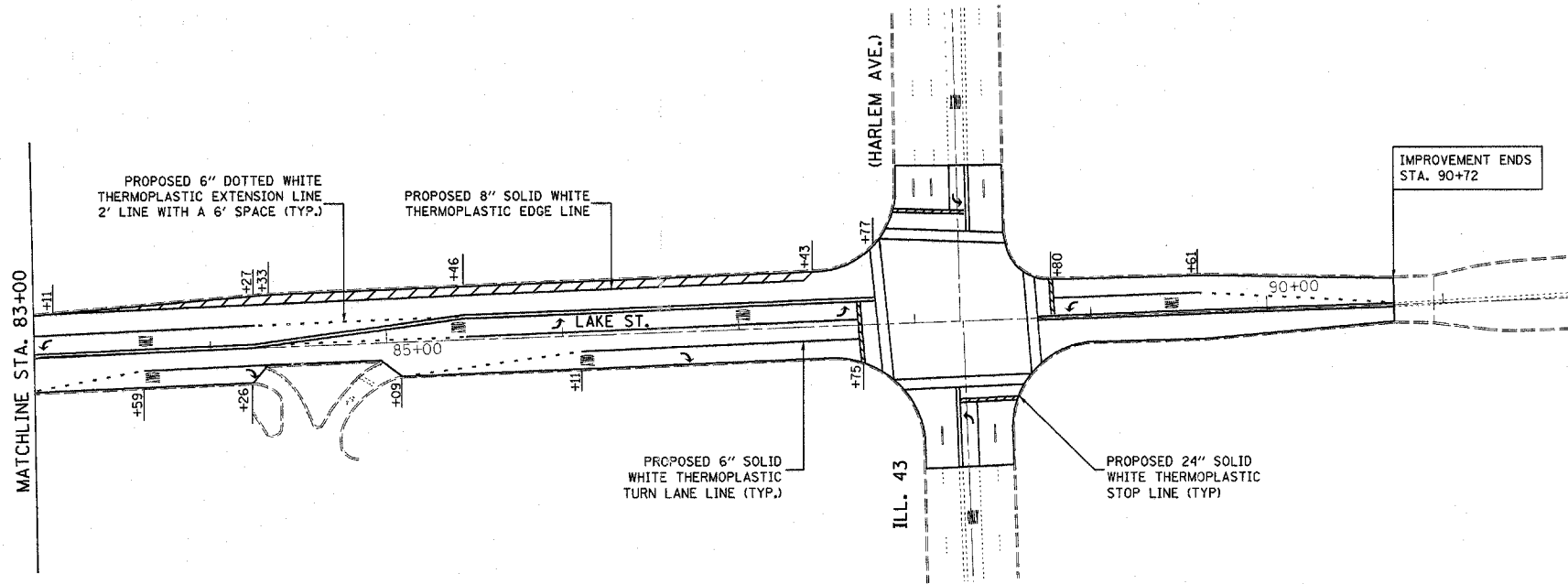
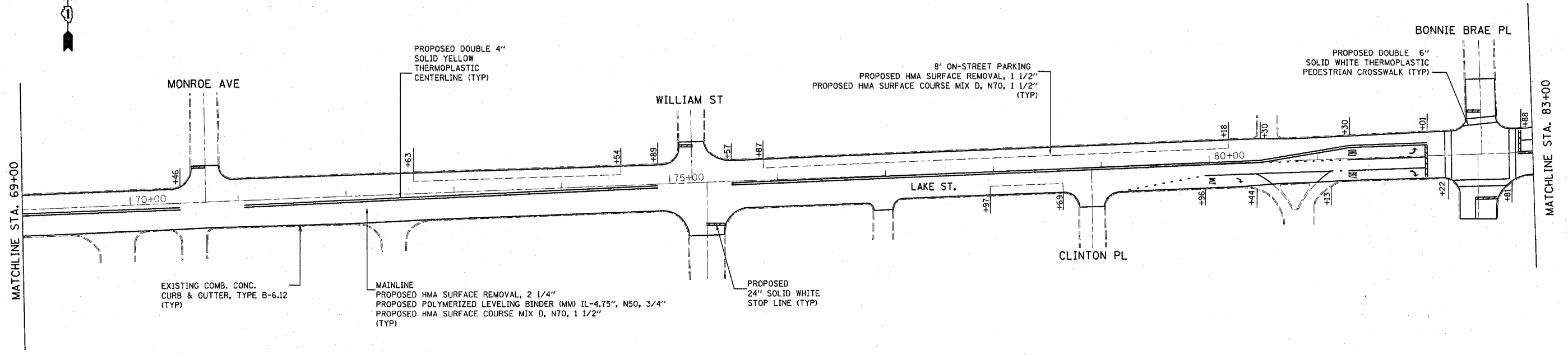

FILE NAME =	USER NAME = rosierjm	DESIGNED J M ROSIERE	REVISED -
ca:\pwwork\pwwid\rosierjm\0159113\1103510-sht-plan.dgn		DRAWN J M ROSIERE	REVISED -
PLOT SCALE = 50,0000' / 1" IN.		CHECKED -	REVISED -
PLOT DATE = 3/20/2010		DATE -	REVISED -

**STATE OF ILLINOIS  
DEPARTMENT OF TRANSPORTATION**

<b>LAKE ST. (IL 171 TO IL 43) ROADWAY AND PAVEMENT MARKING PLANS</b>		
SCALE: 1" = 50'	SHEET NO. 3 OF 3 SHEETS	STA. 69+00 TO STA. 90+72.3

F.A.U. RTE.	SECTION	COUNTY	TOTAL SHEETS	SHEET NO.
3537	3264 RS-7	COOK	22	7
CONTRACT NO. 60161				
ILLINOIS FED. AID PROJECT				

**TRAFFIC SIGNAL LEGEND**

	PROPOSED	EXISTING
DETECTOR LOOP		
SIGNAL HEAD		
G.S. CONDUIT IN TRENCH OR PUSHED		
SIGNAL HEAD WITH BACKPLATE		
RACEWAY FOR MAGNETIC DETECTOR, TYPE I OR II		
VEHICLE DETECTOR, NON-COMPENSATED MAGNETIC TYPE		

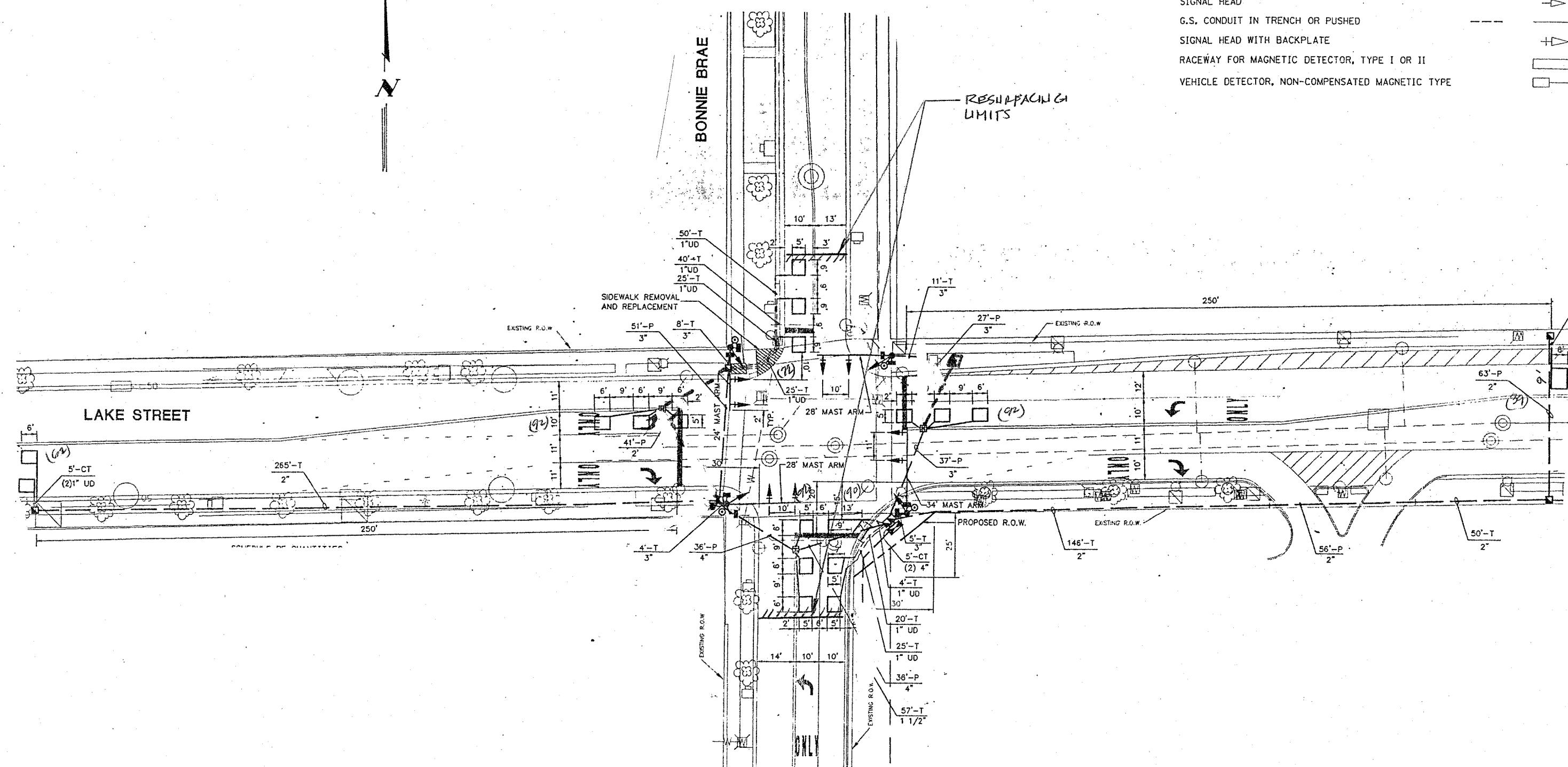

THIS PLAN IS FOR THE SOLE PURPOSE OF DETECTOR LOOP REPLACEMENTS ONLY

REPLACE ALL DETECTOR LOOPS AS SHOWN (WITHIN THE RESURFACING LIMITS)

CODE	QUANTITY	UNIT	ITEM
86600600	539	FOOT	DETECTOR LOOP, REPLACEMENT

FILE NAME =	USER NAME = kxanthaphixaybc	DESIGNED - BCK	REVISED -
c:\pwwork\pwwork\DOT\KANTHAPHIXAYBC\d01126	1\traffic_legend.v7.dgn	DRAWN - BCK	REVISED -
	PLOT SCALE = 3/16" = 1' IN.	CHECKED - DAD	REVISED -
	PLOT DATE = 4/3/2009	DATE	REVISED -

**STATE OF ILLINOIS  
DEPARTMENT OF TRANSPORTATION**

**DISTRICT ONE - DETECTOR LOOP REPLACEMENT  
LAKE STREET @ BONNIE BRAE**

F.A. RTE.	SECTION	COUNTY	TOTAL SHEETS	SHEET NO.
3531	3264 RS-7	COOK	22	8
CONTRACT NO.				

SCALE: NONE SHEET NO. 1 OF 2 SHEETS STA. TO STA. FED. ROAD DIST. NO. ILLINOIS FED. AID PROJECT



**TRAFFIC SIGNAL LEGEND**

	PROPOSED	EXISTING
DETECTOR LOOP		
SIGNAL HEAD		
G.S. CONDUIT IN TRENCH OR PUSHED		
SIGNAL HEAD WITH BACKPLATE		
RACEWAY FOR MAGNETIC DETECTOR, TYPE I OR II		
VEHICLE DETECTOR, NON-COMPENSATED MAGNETIC TYPE		

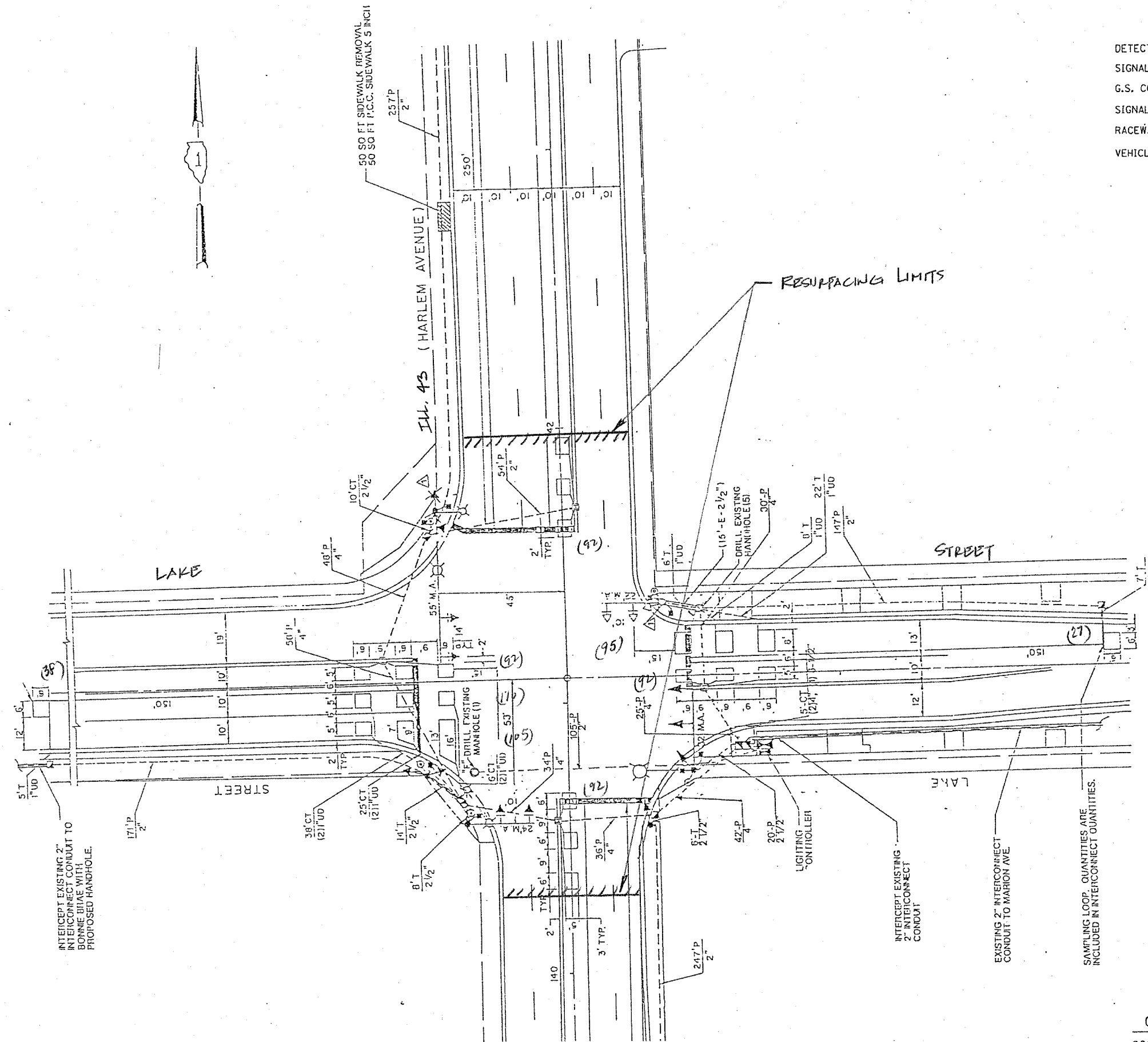

THIS PLAN IS FOR THE SOLE PURPOSE OF DETECTOR LOOP REPLACEMENTS ONLY

REPLACE ALL DETECTOR LOOPS AS SHOWN (WITHIN THE RESURFACING LIMITS)

CODE	QUANTITY	UNIT	ITEM
86600600	743	FOOT	DETECTOR LOOP, REPLACEMENT

FILE NAME =  
 c:\pwwork\VP\WIDOT\KANTHAPHIXAYBC\081126

USER NAME = kanthaphixaybc  
 \*traffico.legend.v7.dgn  
 PLOT SCALE = 3/4" = 1'-0"  
 PLOT DATE = 4/3/2009

DESIGNED - BCK  
 DRAWN - BCK  
 CHECKED - DAD  
 DATE

REVISED -  
 REVISED -  
 REVISED -  
 REVISED -

**STATE OF ILLINOIS  
 DEPARTMENT OF TRANSPORTATION**

**DISTRICT ONE - DETECTOR LOOP REPLACEMENT  
 LAKE STREET @ ILL. RTE. 43 (HARLEM)**

SCALE: NONE SHEET NO. 2 OF 2 SHEETS STA. TO STA.

F.A. RTE.	SECTION	COUNTY	TOTAL SHEETS	SHEET NO.
3531	3264 RS-7	COOK	22	9

CONTRACT NO.

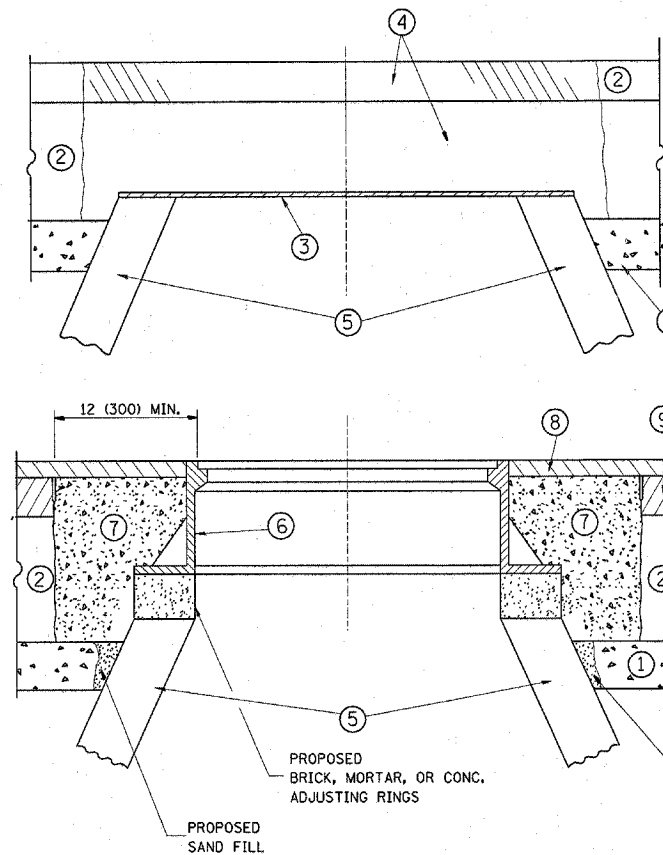

**CONSTRUCTION PROCEDURES**

**STAGE 1 (BEFORE PAVEMENT MILLING)**

- A) REMOVE A MINIMUM OF 12 (300) OF THE PAVEMENT FROM AROUND THE STRUCTURE.
- B) REMOVE THE EXISTING FRAME AND LID FROM THE STRUCTURE.
- C) COVER THE STRUCTURE OPENING WITH A 36 (900) DIAMETER METAL PLATE.
- D) BACKFILL WITH CRUSHED STONE AND A MINIMUM 1 1/2 (40) THICK HMA SURFACE MIX APPROVED BY THE ENGINEER.

**STAGE 2 (AFTER PAVEMENT MILLING)**

- A) REMOVE THE HMA SURFACE MIX AND CRUSHED STONE.
- B) INSTALL THE FRAME AND LID; ADJUST THE FRAME TO ITS FINAL SURFACE ELEVATION.
- C) THE SURROUNDING SPACE SHALL BE FILLED WITH CLASS SI CONCRETE, OR HMA SURFACE COURSE OR HMA BINDER COURSE TO THE ELEVATION OF THE SURFACE OF THE EXISTING BASE COURSE OR THE BINDER COURSE.

THE PROCEDURE EXPLAINED ABOVE SHALL CONFORM TO THE APPLICABLE PORTIONS OF SECTIONS 353, 406, 602, AND 603 OF THE STANDARD SPECIFICATIONS.

**LEGEND**

- ① SUB-BASE GRANULAR MATERIAL
- ② EXISTING PAVEMENT
- ③ 36 (900) DIAMETER METAL PLATE
- ④ PROPOSED CRUSHED STONE AND HMA SURFACE MIX
- ⑤ EXISTING STRUCTURE
- ⑥ FRAME AND LID (SEE NOTES)
- ⑦ CLASS SI CONCRETE, HMA SURFACE COURSE OR HMA BINDER COURSE
- ⑧ PROPOSED HMA SURFACE COURSE
- ⑨ PROPOSED HMA BINDER COURSE

**LOCATION OF STRUCTURES:**

THE CONTRACTOR WILL BE REQUIRED TO KEEP A RECORD OF THE LOCATIONS OF THE BURIED STRUCTURES ACCORDING TO THE STATION AND DISTANCE LEFT OR RIGHT OF THE CENTERLINE OF PAVEMENT. UPON COMPLETION OF THE WORK, THE CONTRACTOR WILL DELIVER THE RECORD TO THE ENGINEER.

**BASIS OF PAYMENT:** THIS WORK WILL BE PAID FOR AT THE CONTRACT UNIT PRICE PER EACH FOR "FRAMES AND LIDS TO BE ADJUSTED, SPECIAL"

NEW FRAMES AND LIDS, WHEN SPECIFIED, WILL BE PAID FOR SEPARATELY.

**NOTES:**

EXISTING BROKEN FRAMES AND LIDS SHALL BE REMOVED AND DISPOSED OF BY THE CONTRACTOR AND SHALL BE REPLACED AS DIRECTED BY THE ENGINEER. REPLACEMENT FRAMES AND LIDS WILL BE PAID FOR IN ACCORDANCE WITH ARTICLE 109.04 OF THE STANDARD SPECIFICATIONS UNLESS A SEPARATE PAY ITEM HAS BEEN PROVIDED.

IF THE EXISTING LIDS ARE OPEN, THE FRAME WILL BE ADJUSTED TO THE ELEVATION OF THE MILLED PAVEMENT SURFACE PRIOR TO THE MILLING OPERATION. THE FRAME WILL NOT BE REMOVED AND COVERED BY THE METAL PLATE.

CITY OF CHICAGO CASTINGS ARE THE PROPERTY OF THE CITY AND THE CONTRACTOR SHALL NOTIFY THE CITY FOR REMOVAL AND DISPOSITION OF THE CASTINGS.

THE METAL PLATE USED TO COVER THE STRUCTURE SHALL REMAIN THE PROPERTY OF THE CONTRACTOR.

WHEN STRUCTURES ARE TO BE ADJUSTED OR RECONSTRUCTED, THE LOWERING AND RAISING OF THE FRAMES AND LIDS WILL NOT BE PAID FOR SEPARATELY BUT WILL BE INCLUDED IN THE COST OF THE CORRESPONDING PAY ITEM.

**DETAILS FOR FRAMES AND LIDS ADJUSTMENT WITH MILLING**

ALL DIMENSIONS ARE IN INCHES (MILLIMETERS) UNLESS OTHERWISE SHOWN

FILE NAME =	USER NAME = rosirejm	DESIGNED - R. SHAH	REVISED - R. SHAH 03-10-95	<b>STATE OF ILLINOIS DEPARTMENT OF TRANSPORTATION</b>	<b>DETAILS FOR FRAMES AND LIDS ADJUSTMENT WITH MILLING</b>			F.A.U. RTE.	SECTION	COUNTY	TOTAL SHEETS	SHEET NO.	
ct:\pwwork\p\WIDOT\ROSIREJM\d2159113\019Std.dgn		DRAWN -	REVISED - A. ABBAS 03-21-97		SCALE: NONE	SHEET NO. 1 OF 1 SHEETS	STA.	TO STA.	3537	3264 RS-7	COOK	22	10
PLOT SCALE = 50.0000' / IN.		CHECKED -	REVISED - R. WIEDEMAN 05-14-04					<b>BD600-03 (BD-8)</b>			<b>CONTRACT NO. 60161</b>		
PLOT DATE = 3/17/2010		DATE - 10-25-94	REVISED - R. BORO 01-01-07					FED. ROAD DIST. NO. 1 ILLINOIS FED. AID PROJECT					

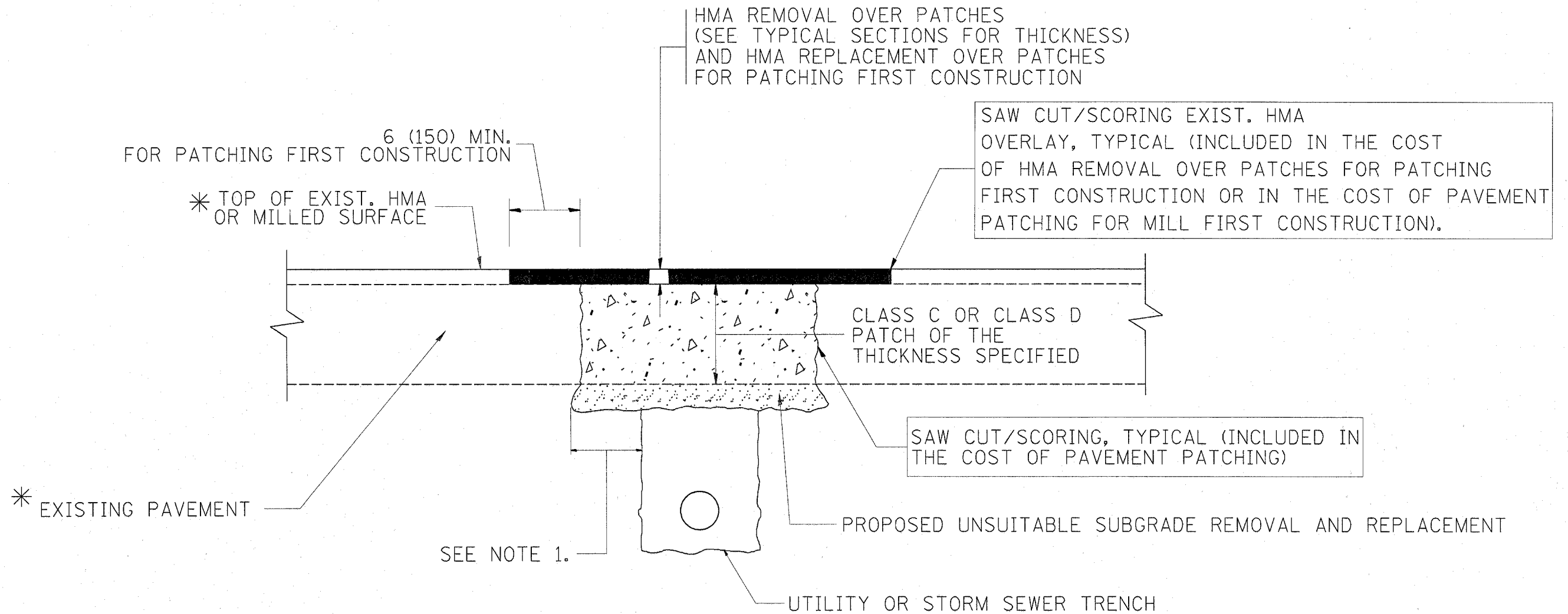

\* SEE TYPICAL SECTIONS FOR THICKNESS AND MATERIALS

**NOTES:**

1. THE WIDTH OF THE FULL DEPTH PATCH OVER A TRENCH SHALL BE 12 (300) WIDER ON EACH SIDE OF THE TRENCH.
2. FOR METHOD OF MEASUREMENT AND BASIS OF PAYMENT, SEE RECURRING SPECIAL PROVISION "PATCHING WITH HOT-MIX ASPHALT OVERLAY REMOVAL".

**SEQUENCE OF CONSTRUCTION (PATCHING FIRST)**

1. REMOVE THE EXISTING HMA MATERIAL OVER THE AREA TO BE PATCHED.
2. REMOVE AND REPLACE WITH CLASS C OR D PATCH.
3. REPLACE HMA MATERIAL OVER THE AREA TO BE PATCHED.

**SEQUENCE OF CONSTRUCTION (MILLING FIRST)**

1. MILL HMA FIRST IF THERE IS AT LEAST 4 1/2 INCHES OR MORE OF HMA MATERIAL ON TOP OF THE EXISTING PAVEMENT OR IF THE PAVEMENT IS FULL DEPTH HMA. A MINIMUM OF 2 INCHES OF HMA MATERIAL SHALL BE IN PLACE AFTER MILLING.
2. REMOVE AND REPLACE WITH FULL DEPTH CLASS D PATCHES TO TOP OF MILLED SURFACE.

ALL DIMENSIONS ARE IN INCHES (MILLIMETERS) UNLESS OTHERWISE SHOWN.

FILE NAME =	USER NAME = rosirejm	DESIGNED - R. SHAH	REVISED - A. ABBAS 04-27-98	<b>STATE OF ILLINOIS DEPARTMENT OF TRANSPORTATION</b>	<b>PAVEMENT PATCHING FOR HMA SURFACED PAVEMENT</b>	F.A.U. RTE.	SECTION	COUNTY	TOTAL SHEETS	SHEET NO.
ca\pw_work\NPWIDOT\ROSIREJM\0159113\0159113.dgn	DRAWN -	REVISED - R. BORO 01-01-07	3537			3264 RS-7	COOK	22	11	
PLOT SCALE = 50.0000 / IN.	CHECKED -	REVISED - R. BORO 09-04-07	<b>BD400-04 (BD-22)</b>			CONTRACT NO. 60161				
PLOT DATE = 3/17/2010	DATE - 10-25-94	REVISED - K. ENG 10-27-08	SCALE: NONE			SHEET NO. 1 OF 1 SHEETS	STA.	TO STA.	FED. ROAD DIST. NO. 1   ILLINOIS   FED. AID PROJECT	

VARIABLE - TO MEET EXISTING DIMENSIONS AND FIELD CONDITIONS (SEE NOTE ②)

PROP. CONC. CURB OR CURB AND GUTTER REPLACEMENT IN ACCORDANCE WITH STATE STANDARD 606001. (SEE NOTE ②)

SAW CUT FULL DEPTH - INCLUDED IN THE COST OF SIDEWALK, DRIVEWAY OR MEDIAN SURFACE REMOVAL PAY ITEM.

SEE STATE STANDARD 606001  
EXISTING OR PROPOSED HMA SURFACE (IF APPLICABLE)

18" (450) MAX.

1/4" (5) \*\*

EXISTING SIDEWALK, DRIVEWAY, MEDIAN SURFACE, SOD OR GROUND.

PROPOSED SIDEWALK, DRIVEWAY PAVEMENT, MEDIAN SURFACE OR SODDING SALT TOLERANT WITH TOP SOIL, 4" (100) SOD RESTORATION (SEE NOTE ①).

EXISTING CONCRETE PAVEMENT, CONCRETE BASE COURSE OR FLEXIBLE PAVEMENT

3" (75) MIN.

SUITABLE BACKFILL MATERIAL (INCLUDED IN THE COST OF CURB OR CURB AND GUTTER REMOVAL AND REPLACEMENT)

\* 3" (75) MINIMUM FROM TOP AND BOTTOM OF THE CONCRETE PAVEMENT OR BASE COURSE.

\*\* IF THE FINAL SURFACE OF THE PAVEMENT IS CONCRETE, THE GUTTER IS TO BE FLUSH WITH THE PAVEMENT.

PROPOSED 3/4" (20) PREFORMED EXPANSION JOINT AT CONCRETE SIDEWALKS, DRIVEWAYS, AND MEDIANS. (INCLUDED IN THE COST OF CURB OR CURB AND GUTTER REMOVAL AND REPLACEMENT.)

NOTE: ① SIDEWALK, DRIVEWAY PAVEMENT OR MEDIAN SURFACE SHALL BE SIMILAR TO THE MATERIAL BEING REMOVED AND WILL BE PAID FOR SEPARATELY.

SODDING, SALT TOLERANT AND TOP SOIL, FURNISH AND PLACE 4" WILL BE PAID FOR SEPARATELY.

UNSUITABLE SUB-BASE MATERIAL TO BE REMOVED, IF DIRECTED BY THE ENGINEER, SHALL BE REPLACED WITH EITHER SUB-BASE GRANULAR MATERIAL, TYPE B OR ADDITIONAL THICKNESS OF CONCRETE.

② FERTILIZER FOR THE PLACEMENT OF THE SOD IS NOT REQUIRED

③ CURB OR CURB AND GUTTER REPLACEMENT SHALL MATCH THE SHAPE OF THE EXISTING CURB OR CURB AND GUTTER UNLESS OTHERWISE SPECIFIED.

REMOVAL AND REPLACEMENT 4" (100) OR LESS IS INCLUDED IN THE COST OF CURB OR CURB AND GUTTER REMOVAL AND REPLACEMENT.

④ FOR CURB OR CURB AND GUTTER REMOVAL AND REPLACEMENT ADJACENT TO FLEXIBLE PAVEMENT DELETE EPOXY COATED TIE BARS.

REMOVAL AND REPLACEMENT IN EXCESS OF 4" (100) WILL BE PAID FOR IN ACCORDANCE WITH ARTICLE 109.04 OF THE STANDARD SPECIFICATIONS.

⑤ LONGITUDINAL BARS, IF ENCOUNTERED IN THE EXISTING CURB OR CURB AND GUTTER, ARE NOT TO BE REPLACED. CUTTING AND REMOVING LONGITUDINAL BARS SHALL BE INCLUDED IN THE COST OF CURB OR CURB AND GUTTER REMOVAL AND REPLACEMENT.

PROPOSED #6 (20) EPOXY COATED TIE BARS 24" (600) LONG AT 24" (600) CENTERS WILL NOT BE PAID FOR SEPARATELY. DELETE EPOXY COATED TIE BARS IF EXISTING TIE BARS ARE USUABLE AS DETERMINED BY THE ENGINEER. (SEE NOTE ③).

⑥ THE COST OF HMA SURFACE REMOVAL IN THE EXISTING GUTTER FLAG SHALL BE INCLUDED IN THE COST OF THE CURB AND GUTTER REMOVAL AND REPLACEMENT.

**BASIS OF PAYMENT:**

THIS WORK WILL BE PAID FOR AT THE CONTRACT UNIT PRICE PER FOOT (METER) FOR "CURB REMOVAL AND REPLACEMENT" OR "COMBINATION CONCRETE CURB AND GUTTER REMOVAL AND REPLACEMENT".

⑦ THE REMOVAL AND REPLACEMENT OF THE EXISTING CURB OR CURB AND GUTTER SHALL BE DONE IN ACCORDANCE WITH THE APPLICABLE PORTIONS OF SECTION 440 AND 606 OF THE STANDARD SPECIFICATIONS.

⑧ THE LOCATIONS OF REMOVAL AND REPLACEMENT OF EXISTING CURB OR CURB AND GUTTER SHALL BE DETERMINED BY THE RESIDENT ENGINEER AT THE TIME OF CONSTRUCTION.

# CURB OR CURB AND GUTTER REMOVAL AND REPLACEMENT

ALL DIMENSIONS ARE IN INCHES (MILLIMETERS) UNLESS OTHERWISE SHOWN.

FILE NAME =	USER NAME = rosierjm	DESIGNED - A. HOUSEH	REVISED - R. SHAH 10-03-96
cr:\pw_work\PWIDOT\ROSIERJM\d0159113\Draw	Std.dgn	DRAWN -	REVISED - A. ABBAS 03-21-97
	PLOT SCALE = 50.0000" / IN.	CHECKED -	REVISED - M. GOMEZ 01-22-01
	PLOT DATE = 3/17/2010	DATE - 03-11-94	REVISED - R. BORO 12-15-09

STATE OF ILLINOIS  
DEPARTMENT OF TRANSPORTATION

CURB OR CURB AND GUTTER  
REMOVAL AND REPLACEMENT

SCALE: NONE SHEET NO. 1 OF 1 SHEETS STA. TO STA.

F.A.U. RTE.	SECTION	COUNTY	TOTAL SHEETS	SHEET NO.
3537	3264 RS-7	COOK	22	12
BD600-06 (BD-24)		CONTRACT NO. 60161		
FED. ROAD DIST. NO. 1 ILLINOIS FED. AID PROJECT				

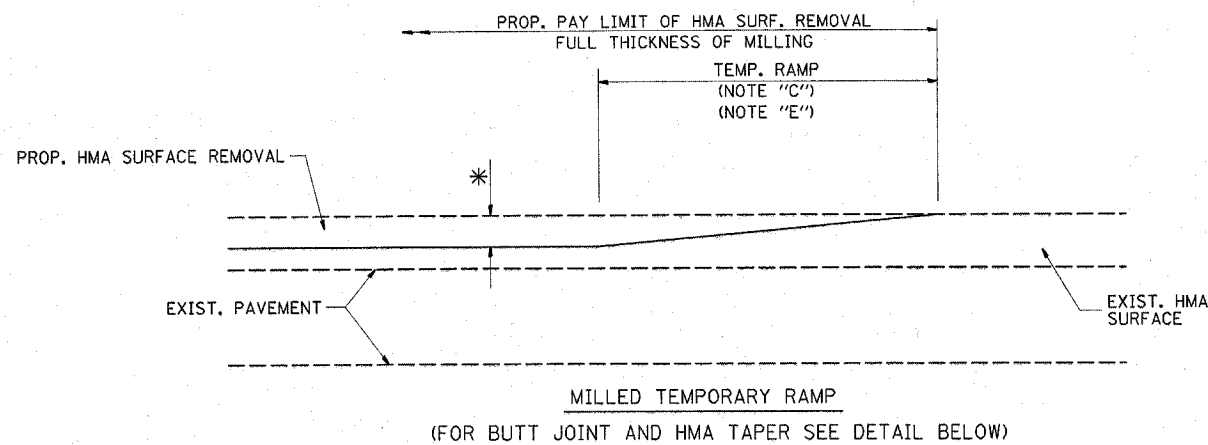

**OPTION 1**

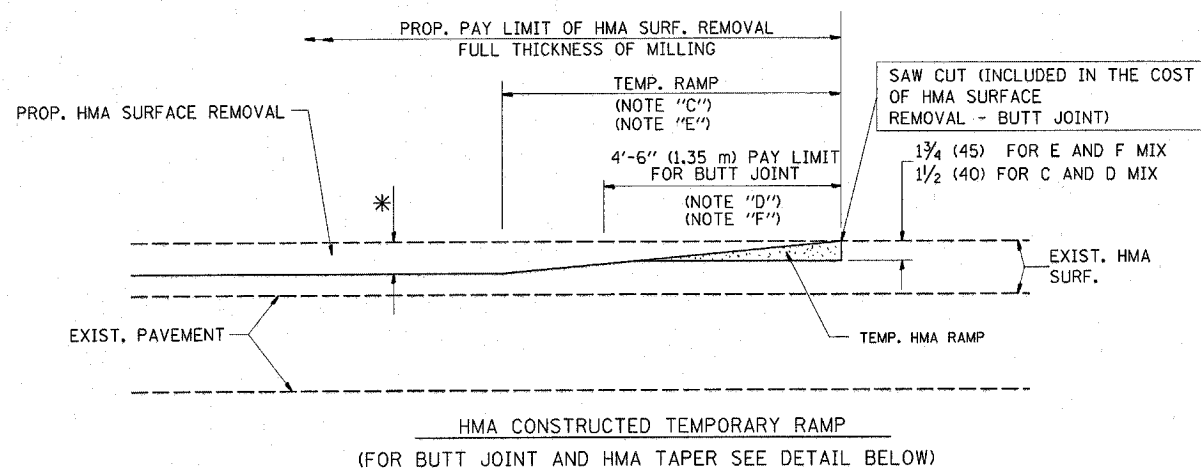

**OPTION 2  
TYPICAL TEMPORARY RAMP**

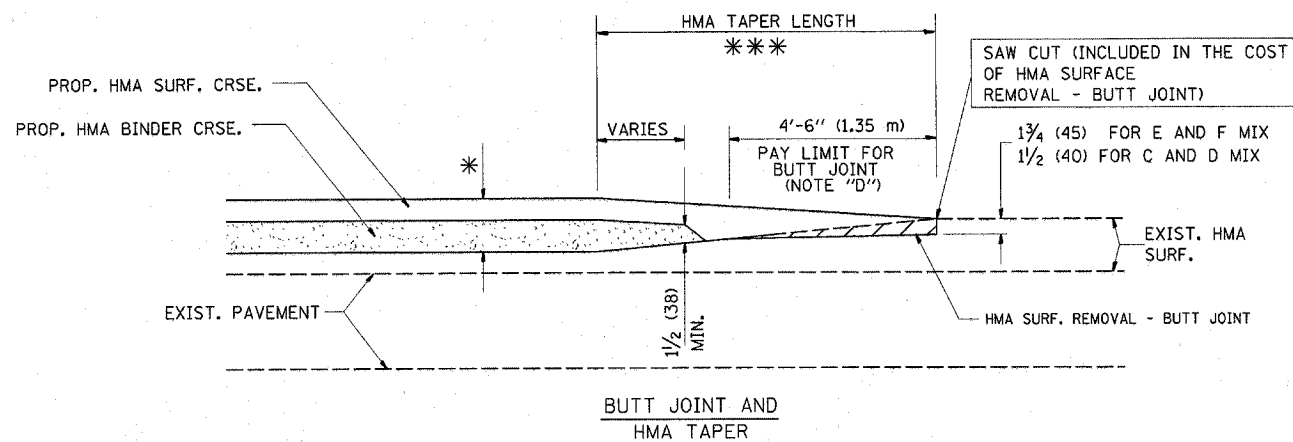

**TYPICAL BUTT JOINT AND HMA TAPER  
FOR MILLING AND RESURFACING**

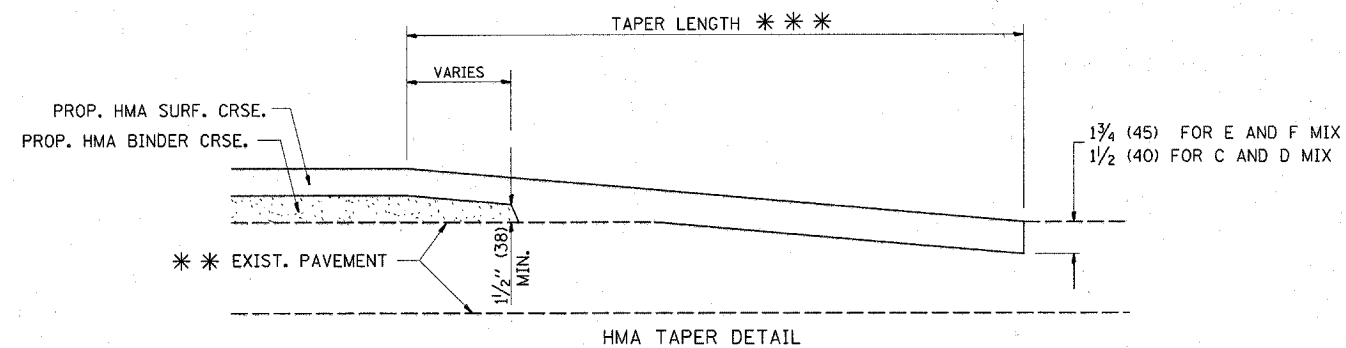
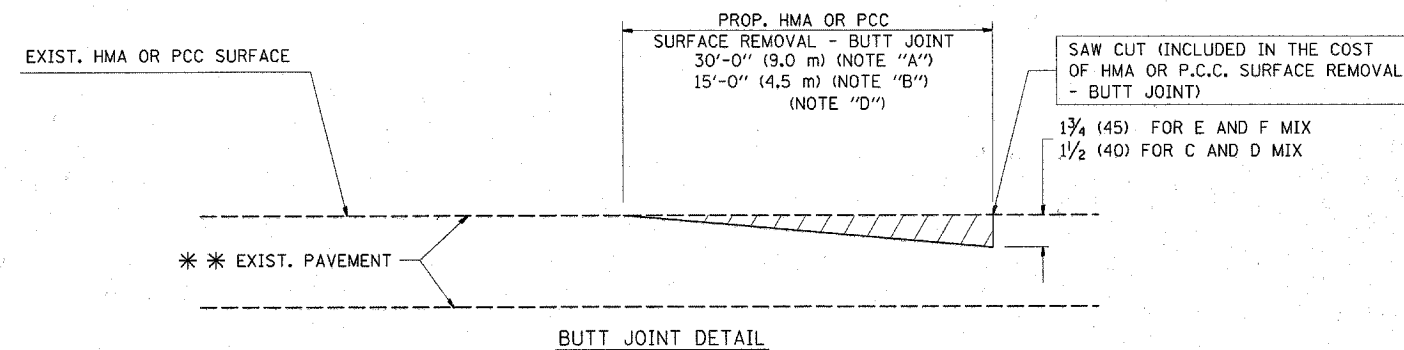

**TYPICAL BUTT JOINT AND HMA TAPER  
FOR RESURFACING ONLY**

\*\*\* PC CONCRETE, HMA OR HMA RESURFACED PAVEMENT.

**NOTES**

- A: MAINLINE ROADWAYS AND MAJOR SIDE ROADS.
  - B: MINOR SIDE ROADS.
  - C: THE TEMP. RAMP SHALL BE CONSTRUCTED IMMEDIATELY UPON REMOVAL OF THE EXISTING HMA SURFACE.
  - D: THE BUTT JOINT SHALL BE CONSTRUCTED IMMEDIATELY PRIOR TO PLACING THE PROPOSED HMA COURSES.
  - E: TAPER THE TEMP. RAMP AT A RATE OF 3'-0" (900 mm) PER 1 INCH (25 mm) OF MILLING THICKNESS.
  - F: INSTALLATION AND REMOVAL OF THE 4'-6" (1.35 m) TEMP. RAMP IS INCLUDED IN COST OF HMA SURFACE REMOVAL - BUTT JOINT
  - G: SEE ARTICLE 406.08 AND 406.14 OF THE STANDARD SPECIFICATIONS FOR "HMA AND/OR PCC SURFACE REMOVAL, BUTT JOINT".
- \* SEE TYPICAL SECTIONS FOR MILLING THICKNESS.
- \*\*\* 20'-0" (6.1 m) PER 1 (25) RESURFACING (NOTE "A")  
10'-0" (3.0 m) PER 1 (25) RESURFACING (NOTE "B")

**BASIS OF PAYMENT:**

THE BUTT JOINT WILL BE PAID FOR AT THE CONTRACT UNIT PRICE PER SQUARE YARD (SQUARE METER) FOR "HOT-MIX ASPHALT SURFACE REMOVAL - BUTT JOINT" OR FOR "PORTLAND CEMENT CONCRETE SURFACE REMOVAL - BUTT JOINT".

ALL DIMENSIONS ARE IN INCHES (MILLIMETERS) UNLESS OTHERWISE SHOWN.

FILE NAME =	USER NAME = rosierjm	DESIGNED - M. DE YONG	REVISED - R. SHAH 10-25-94
ca:\pwork\PM1DOT\ROSIERJ\10159113\01\Std.dgn		DRAWN -	REVISED - A. ABBAS 03-21-97
	PLOT SCALE = 50.0000' / IN.	CHECKED -	REVISED - M. GOMEZ 04-06-01
	PLOT DATE = 3/17/2010	DATE - 06-13-90	REVISED - R. BORO 01-01-07

**STATE OF ILLINOIS  
DEPARTMENT OF TRANSPORTATION**

**BUTT JOINT AND  
HMA TAPER DETAILS**

SCALE: NONE SHEET NO. 1 OF 1 SHEETS STA. TO STA.

F.A.U. RTE.	SECTION	COUNTY	TOTAL SHEETS	SHEET NO.
3537	3264 RS-7	COOK	22	13
BD400-05 BD32			CONTRACT NO. 60161	
FED. ROAD DIST. NO. 1 ILLINOIS FED. AID PROJECT				

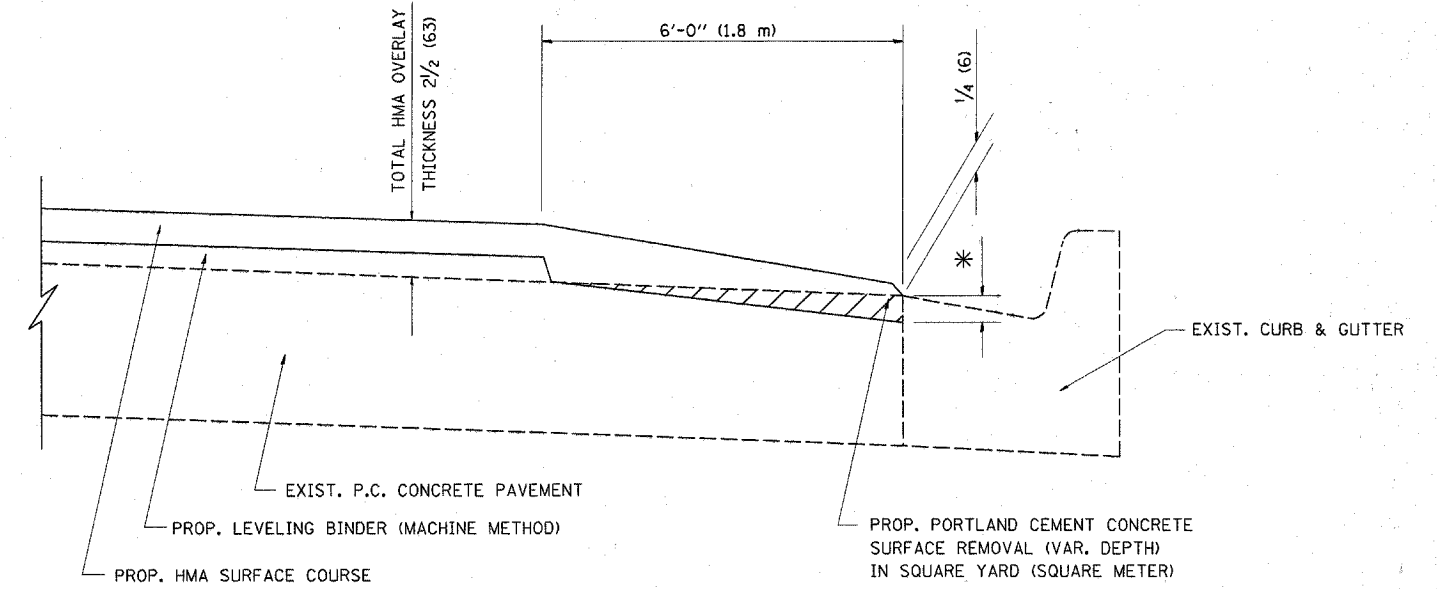

HMA TAPER AT  
EDGE OF P.C.C. PAVEMENT

HMA SURFACE	LEVELING BINDER	MIX	THICKNESS	THICKNESS	* MILLING AT GUTTER FLAG
C OR D	1	1/2 (38)	1 (25)	1/4 (33)	
F	3/4	1 3/4 (44)	3/4 (19)	1/2 (38)	

ALL DIMENSIONS ARE IN INCHES (MILLIMETERS) UNLESS OTHERWISE SHOWN.

FILE NAME =	USER NAME = rosier@jrn	DESIGNED - R. SHAH	REVISED - R. SHAH 10-25-94
of\pwwork\VP\WIDOT\ROSTEREJM\d0159113\13\13Std.dgn		DRAWN - JIS	REVISED - A. ABBAS 05-05-99
	PLOT SCALE = 50.0000 / IN.	CHECKED - A. ABBAS	REVISED - E. GOMEZ 12-21-00
	PLOT DATE = 3/17/2010	DATE - 09-10-94	REVISED - R. BORO 01-01-07

STATE OF ILLINOIS  
DEPARTMENT OF TRANSPORTATION

HMA TAPER AT EDGE OF P.C.C. PAVEMENT			
SCALE: NONE	SHEET NO. 1 OF 1 SHEETS	STA.	TO STA.

F.A.U. RTE.	SECTION	COUNTY	TOTAL SHEETS	SHEET NO.
3537	3264 RS-7	COOK	22	14
BD400-06 (BD33)		CONTRACT NO. 60161		
FED. ROAD DIST. NO. 1 ILLINOIS FED. AID PROJECT				

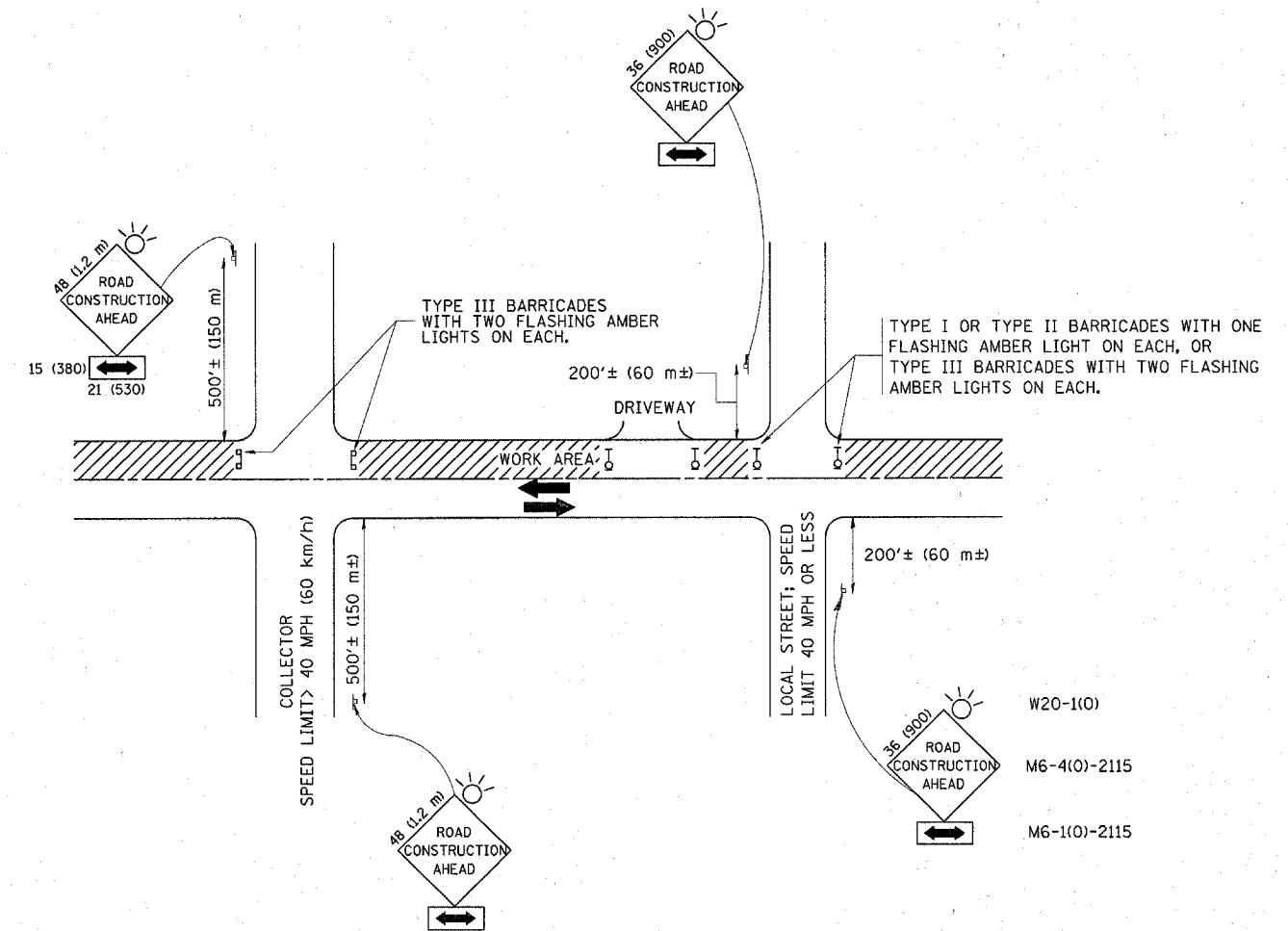

TRAFFIC CONTROL AND PROTECTION FOR SIDE ROADS, INTERSECTIONS, AND DRIVEWAYS

NOTES:

- A. FOR NO LANE RESTRICTION ON THE SIDE ROAD OR DRIVEWAYS
  1. SIDE ROAD WITH A SPEED LIMIT OF 40 MPH (60 km/h) OR LESS AS SHOWN ON THE DRAWING AND AS DIRECTED BY THE ENGINEER:
    - a) ONE ROAD CONSTRUCTION AHEAD SIGN 36 x 36 (900x900) WITH A FLASHER AND FLAG MOUNTED ON IT APPROXIMATELY 200' (60 m) IN ADVANCE OF THE MAIN ROUTE.
    - b) THE CLOSED PORTION OF THE MAIN ROUTE SHALL BE PROTECTED BY BLOCKING WITH TYPE I, TYPE II OR TYPE III BARRICADES, 1/3 OF THE CROSS SECTION OF THE CLOSED PORTION.
  2. SIDE ROAD WITH A SPEED LIMIT GREATER THAN 40 MPH (60 km/h) AS SHOWN ON THE DRAWING AND AS DIRECTED BY THE ENGINEER:
    - a) ONE ROAD CONSTRUCTION AHEAD SIGN 48 x 48 (1.2 m x 1.2 m) WITH A FLASHER MOUNTED ON IT APPROXIMATELY 500' (150 m) IN ADVANCE OF THE MAIN ROUTE.
    - b) THE CLOSED PORTION OF THE MAIN ROUTE SHALL BE PROTECTED BY BLOCKING WITH TYPE III BARRICADES, 1/2 OF THE CROSS SECTION OF THE CLOSED PORTION.
  3. WHEN THE SIDE ROAD LIES BETWEEN THE BEGINNING OF THE MAINLINE SIGNING AND THE WORK ZONE, A SINGLE HEADED ARROW (M6-1) SHALL BE USED IN LIEU OF THE DOUBLE HEADED ARROW (M6-4).
- B. FOR A LANE CLOSURE ON A SIDE ROAD OR DRIVEWAY:
 

USE APPLICABLE PORTIONS OF THE TYPICAL APPLICATION OF TRAFFIC CONTROL DEVICES (STD. 701501, STD. 701606 OR THE APPROPRIATE STANDARD). THE SPACING OF SIGNS AND BARRICADES SHALL BE ADJUSTED FOR FIELD CONDITIONS AS DIRECTED BY THE ENGINEER. THE DIRECTIONAL ARROW SHALL BE COVERED OR REMOVED WHEN NO LONGER CONSISTENT WITH THE SIDE ROAD LANE CLOSURE.

  - C. ADVANCE WARNING SIGNS ARE TO BE OMITTED ON DRIVEWAY UNLESS OTHERWISE NOTED.
  - D. THE TRAFFIC CONTROL AND PROTECTION FOR SIDE ROADS, INTERSECTIONS, AND DRIVEWAYS SHALL BE INCIDENTAL TO THE COST OF SPECIFIED TRAFFIC CONTROL STANDARDS OR ITEMS.

All dimensions are in millimeters (Inches) unless otherwise shown.

FILE NAME =	USER NAME = rosierjrn	DESIGNED - LHA	REVISED - J. OBERLE 10-18-95
ct:\pw\work\NPW100T\ROSIEREJRN\d0159113\Des	Std.dgn	DRAWN -	REVISED - A. HOUSEH 03-06-96
	PLOT SCALE = 50.0000" / IN.	CHECKED -	REVISED - A. HOUSEH 10-15-96
	PLOT DATE = 3/17/2010	DATE - 06-89	REVISED - T. RAMMACHER 01-06-00

STATE OF ILLINOIS  
DEPARTMENT OF TRANSPORTATION

TRAFFIC CONTROL AND PROTECTION FOR  
SIDE ROADS, INTERSECTIONS, AND DRIVEWAYS

SCALE: NONE SHEET NO. 1 OF 1 SHEETS STA. TO STA.

F.A.U. RTE.	SECTION	COUNTY	TOTAL SHEETS	SHEET NO.
3537	3264 RS-7	COOK	22	15
TC-10			CONTRACT NO. 60161	
FED. ROAD DIST. NO. 1 ILLINOIS FED. AID PROJECT				

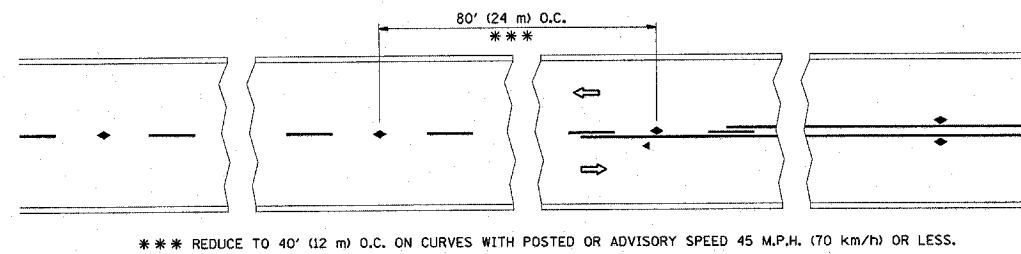

TWO-LANE/TWO-WAY

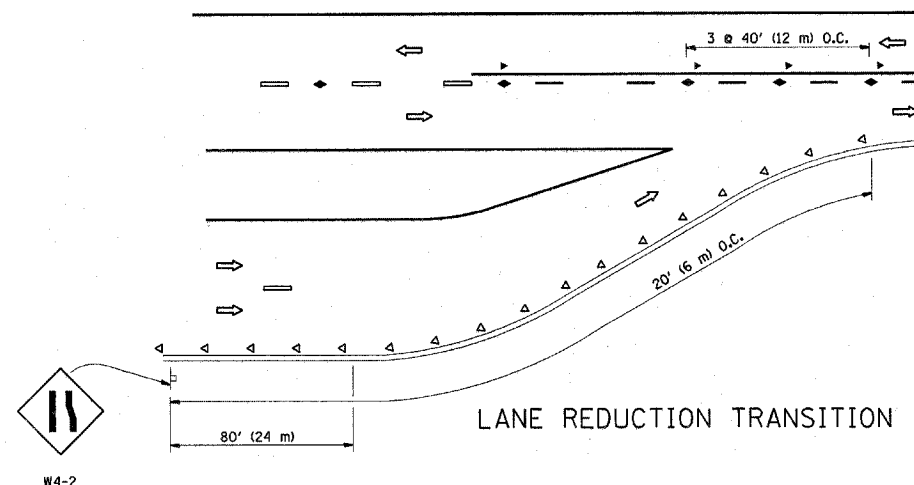

LANE REDUCTION TRANSITION

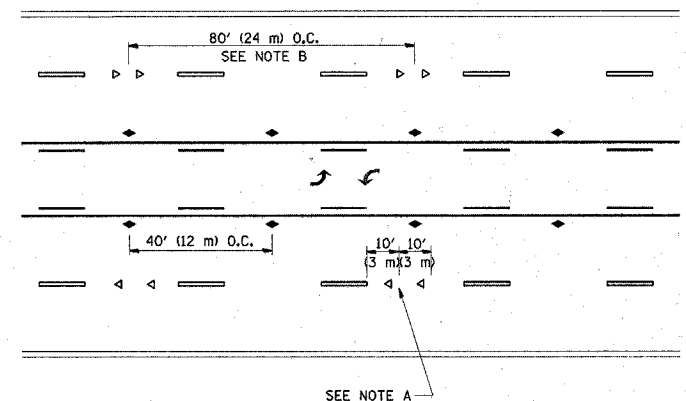

TWO-WAY LEFT TURN

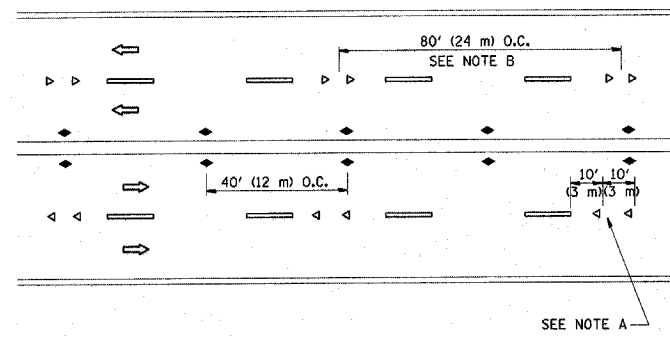

MULTI-LANE/UNDIVIDED

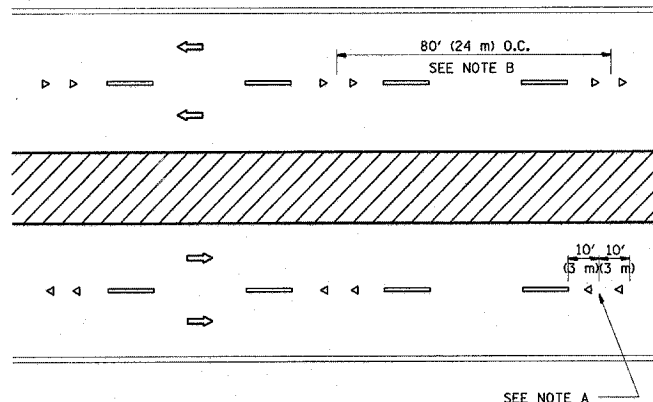

MULTI-LANE/DIVIDED

GENERAL NOTES

1. MARKERS USED WITH DASHED LINES SHALL BE CENTERED IN THE GAP BETWEEN SEGMENTS.
2. MARKERS USED ADJACENT TO SOLID LINES SHALL BE OFFSET 2 TO 3 (50 TO 75) TOWARD TRAFFIC AS SHOWN.
3. MARKERS THROUGH TANGENTS LESS THAN 500' (150 m) IN LENGTH BETWEEN CURVES SHALL BE INSTALLED AT THE LESSER OF THE TWO CURVE SPACINGS.

SYMBOLS

- YELLOW STRIPE
- WHITE STRIPE
- ◀ ONE-WAY AMBER MARKER
- ◁ ONE-WAY CRYSTAL MARKER (W/O)
- ◆ TWO-WAY AMBER MARKER

LANE MARKER NOTES

- A. USE DOUBLE LANE LINE MARKERS SPACED AS SHOWN.
- B. REDUCE TO 40' (12 m) O.C. ON CURVES WHERE ADVISORY SPEEDS ARE 10 M.P.H. (20 km/h) LOWER THAN POSTED SPEEDS.

DESIGN NOTES

1. DOUBLE LANE LINE MARKERS SHALL BE USED UNLESS SPECIFIED OTHERWISE.
2. EXCEPT AS SHOWN ON THE LANE REDUCTION TRANSITION AND FREEWAY EXIT RAMP DETAIL, MARKERS ARE NOT TO BE SPECIFIED ON RIGHT EDGE LINES.
3. THE EXACT MARKER LIMITS, SPACING, AND COLOR SHOULD BE INCLUDED IN THE PLANS.
4. MARKERS SHOULD NOT BE USED ALONGSIDE CURBS EXCEPT FOR EXTREMELY SHORT SECTIONS OF CURBS WHERE NOT MORE THAN TWO MARKERS WOULD BE INVOLVED.

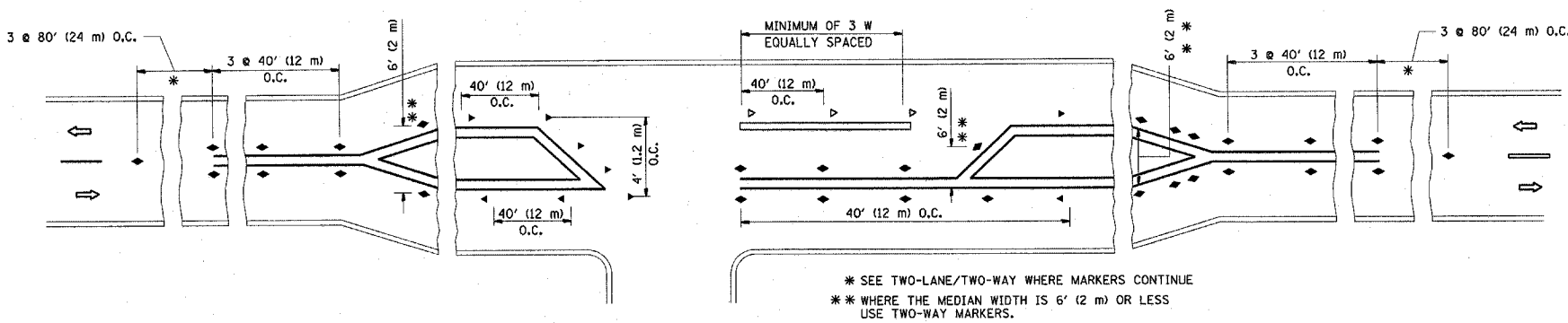

LEFT TURN

\* SEE TWO-LANE/TWO-WAY WHERE MARKERS CONTINUE  
 \*\* WHERE THE MEDIAN WIDTH IS 6' (2 m) OR LESS USE TWO-WAY MARKERS.

All dimensions are in inches (millimeters) unless otherwise shown.

FILE NAME =	USER NAME = rosierejm	DESIGNED -	REVISED - T. RAMMACHER 09-19-94	<b>STATE OF ILLINOIS DEPARTMENT OF TRANSPORTATION</b>	<b>TYPICAL APPLICATIONS RAISED REFLECTIVE PAVEMENT MARKERS (SNOW-PLOW RESISTANT)</b>			F.A.U. RTE.	SECTION	COUNTY	TOTAL SHEETS	SHEET NO.
or:\pw\work\PWIDOT\ROSIEREJM\d0159113\0159113.dgn		DRAWN -	REVISED - T. RAMMACHER 03-12-99		3537	3264 RS-7	COOK	22	16			
		CHECKED -	REVISED - T. RAMMACHER 01-06-00		<b>TC-11</b>			CONTRACT NO. 60161				
		DATE	REVISED - C. JUCIUS 09-09-09		SCALE: NONE	SHEET NO. 1 OF 1 SHEETS	STA.	TO STA.	FED. ROAD DIST. NO. 1 ILLINOIS FED. AID PROJECT			



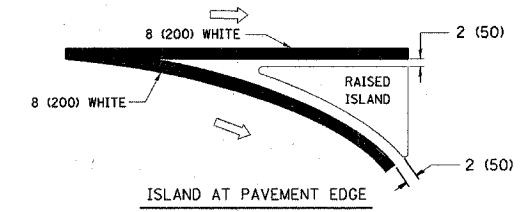
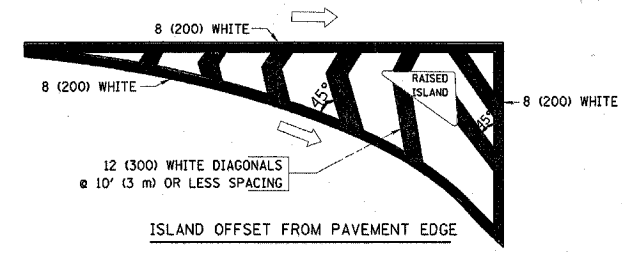
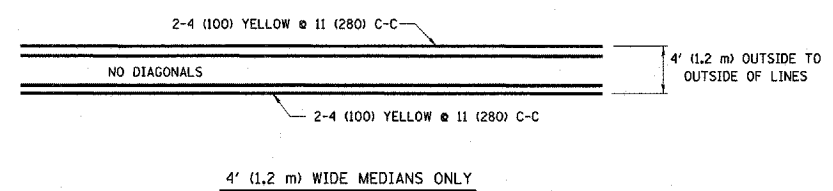
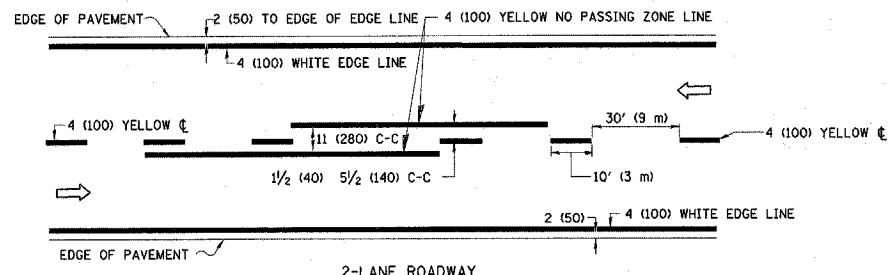

TYPICAL ISLAND MARKING

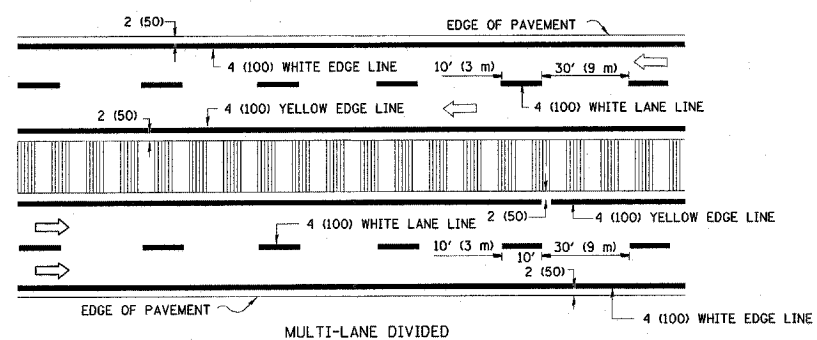
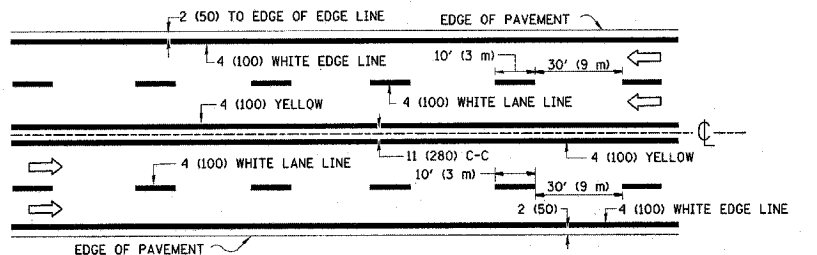

NOTE: MEDIANS WITH BARRIER CURB DO NOT REQUIRE AN EDGE LINE

TYPICAL LANE AND EDGE LINE MARKING

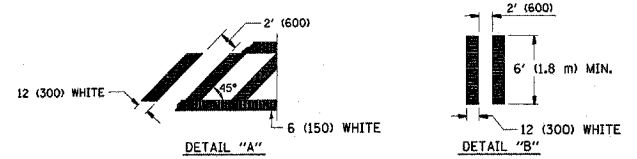
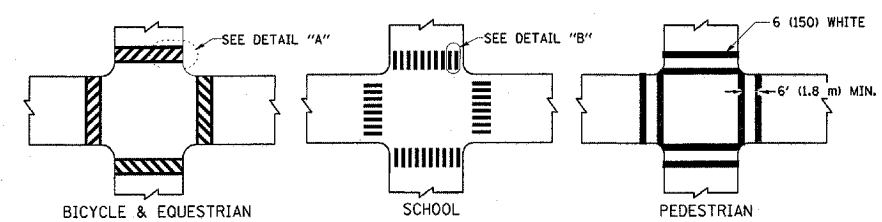

TYPICAL CROSSWALK MARKING

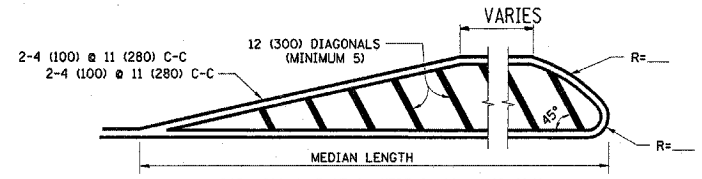

FOR MEDIAN LENGTHS WHERE DIAGONAL SPACING CANNOT BE ATTAINED, USE 5 (FIVE) EQUALLY SPACED DIAGONAL LINES.

DIAGONAL LINE SPACING: 50' (15 m) C-C (LESS THAN 30MPH (50 km/h))  
75' (25 m) C-C 30MPH (50 km/h) TO 45MPH (70 km/h)  
150' (45 m) C-C (MORE THAN 45MPH (70 km/h))

MEDIANS OVER 4' (1.2 m) WIDE

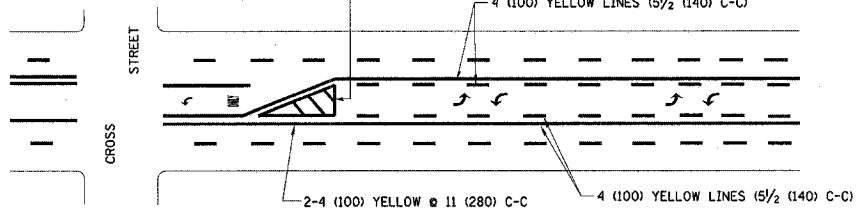

A MINIMUM OF TWO PAIRS OF TURN ARROWS SHALL BE USED, WHITE IN COLOR. ADDITIONAL PAIRS SHALL BE PLACED AT 200' (60 m) TO 300' (90 m) INTERVALS.

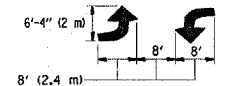

MEDIAN WITH TWO-WAY LEFT TURN LANE

TYPICAL PAINTED MEDIAN MARKING

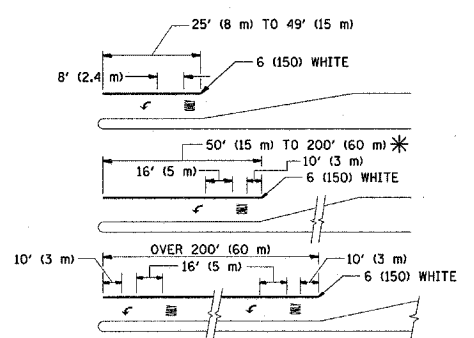

FULL SIZE LETTERS 8' (2.4 m) AND ARROWS SHALL BE USED.  
AREA = 15.6 SQ. FT. (1.5 m<sup>2</sup>) ONLY AREA = 20.8 SQ. FT. (1.9 m<sup>2</sup>)

\* TURN LANES IN EXCESS OF 400' (120 m) IN LENGTH MAY HAVE AN ADDITIONAL SET OF ARROW - "ONLY" INSTALLED MIDWAY BETWEEN THE OTHER TWO SETS OF ARROW - "ONLY".

TYPICAL LEFT (OR RIGHT) TURN LANE

TYPICAL TURN LANE MARKING

TYPE OF MARKING	WIDTH OF LINE	PATTERN	COLOR	SPACING / REMARKS
CENTERLINE ON 2 LANE PAVEMENT	4 (100)	SKIP-DASH	YELLOW	10' (3 m) LINE WITH 30' (9 m) SPACE
CENTERLINE ON MULTI-LANE UNDIVIDED PAVEMENT	2 @ 4 (100)	SOLID	YELLOW	11 (280) C-C
NO PASSING ZONE LINES: FOR ONE DIRECTION	4 (100)	SOLID	YELLOW	5/2 (140) C-C FROM SKIP-DASH CENTERLINE
NO PASSING ZONE LINES: FOR BOTH DIRECTIONS	2 @ 4 (100)	SOLID	YELLOW	11 (280) C-C OMIT SKIP-DASH CENTERLINE BETWEEN
LANE LINES	4 (100) 5 (125) ON FREEWAYS	SKIP-DASH SKIP-DASH	WHITE WHITE	10' (3 m) LINE WITH 30' (9 m) SPACE
DOTTED LINES (EXTENSIONS OF CENTER, LANE OR TURN LANE MARKINGS)	SAME AS LINE BEING EXTENDED	SKIP-DASH	SAME AS LINE BEING EXTENDED	2' (600) LINE WITH 6' (1.8 m) SPACE
EDGE LINES	4 (100)	SOLID	YELLOW-LEFT WHITE-RIGHT	OUTLINE MOUNTABLE MEDIANS IN YELLOW; EDGE LINES ARE NOT USED NEXT TO BARRIER CURB
TURN LANE MARKINGS	6 (150) LINE; FULL SIZE LETTERS & SYMBOLS (8' (2.4m))	SOLID	WHITE	SEE TYPICAL TURN LANE MARKING DETAIL
TWO WAY LEFT TURN MARKING	2 @ 4 (100) EACH DIRECTION	SKIP-DASH AND SOLID	YELLOW	10' (3 m) LINE WITH 30' (9 m) SPACE FOR SKIP-DASH 5/2 (140) C-C BETWEEN SOLID LINE AND SKIP-DASH LINE
	8' (2.4m) LEFT ARROW	IN PAIRS	WHITE	SEE TYPICAL TWO-WAY LEFT TURN MARKING DETAIL
CROSSWALK LINES (PEDESTRIAN)	2 @ 6 (150)	SOLID	WHITE	NOT LESS THAN 6' (1.8 m) APART
A. DIAGONALS (BIKE & EQUESTRIAN)	12 (300) @ 45°	SOLID	WHITE	2' (600) APART
B. LONGITUDINAL BARS (SCHOOL)	12 (300) @ 90°	SOLID	WHITE	2' (600) APART
				SEE TYPICAL CROSSWALK MARKING DETAILS.
STOP LINES	24 (600)	SOLID	WHITE	PLACE 4' (1.2 m) IN ADVANCE OF AND PARALLEL TO CROSSWALK, IF PRESENT. OTHERWISE, PLACE AT DESIRED STOPPING POINT. PARALLEL TO CROSSROAD CENTERLINE, WHERE POSSIBLE
PAINTED MEDIANS	2 @ 4 (100) WITH 12 (300) DIAGONALS @ 45°	SOLID	YELLOW; TWO WAY TRAFFIC WHITE; ONE WAY TRAFFIC	11 (280) C-C FOR THE DOUBLE LINE SEE TYPICAL PAINTED MEDIAN MARKING.
GORE MARKING AND CHANNELIZING LINES	8 (200) WITH 12 (300) DIAGONALS @ 45°	SOLID	WHITE	DIAGONALS: 15' (4.5 m) C-C (LESS THAN 30MPH (50 km/h)) 20' (6 m) C-C 30MPH (50 km/h) TO 45MPH (70 km/h) 30' (9 m) C-C (OVER 45MPH (70 km/h))
RAILROAD CROSSING	24 (600) TRANSVERSE LINES; "RR" IS 6' (1.8 m) LETTERS; 16 (400) LINE FOR "X"	SOLID	WHITE	SEE STATE STANDARD 780001 AREA OF: "RR"=3.6 SQ. FT. (0.33 m <sup>2</sup> ) EACH "X"=54.0 SQ. FT. (5.0 m <sup>2</sup> )
SHOULDER DIAGONALS	12 (300) @ 45°	SOLID	WHITE - RIGHT YELLOW - LEFT	50' (15 m) C-C (LESS THAN 30MPH (50 km/h)) 75' (25 m) C-C (30 MPH (50 km/h) TO 45MPH (70 km/h)) 150' (45 m) C-C (OVER 45MPH (70 km/h))

FOR FURTHER DETAILS ON PAVEMENT MARKING REFER TO STANDARD SPECIFICATIONS FOR ROAD AND BRIDGE CONSTRUCTION AND STATE STANDARD 780001.

All dimensions are in inches (millimeters) unless otherwise shown.

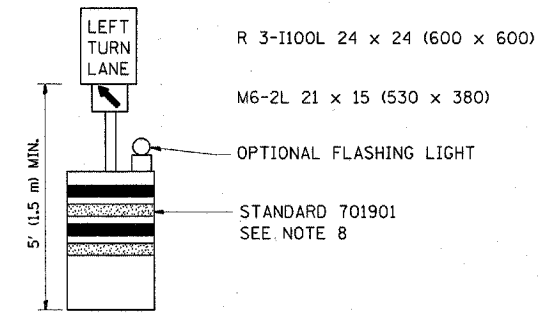
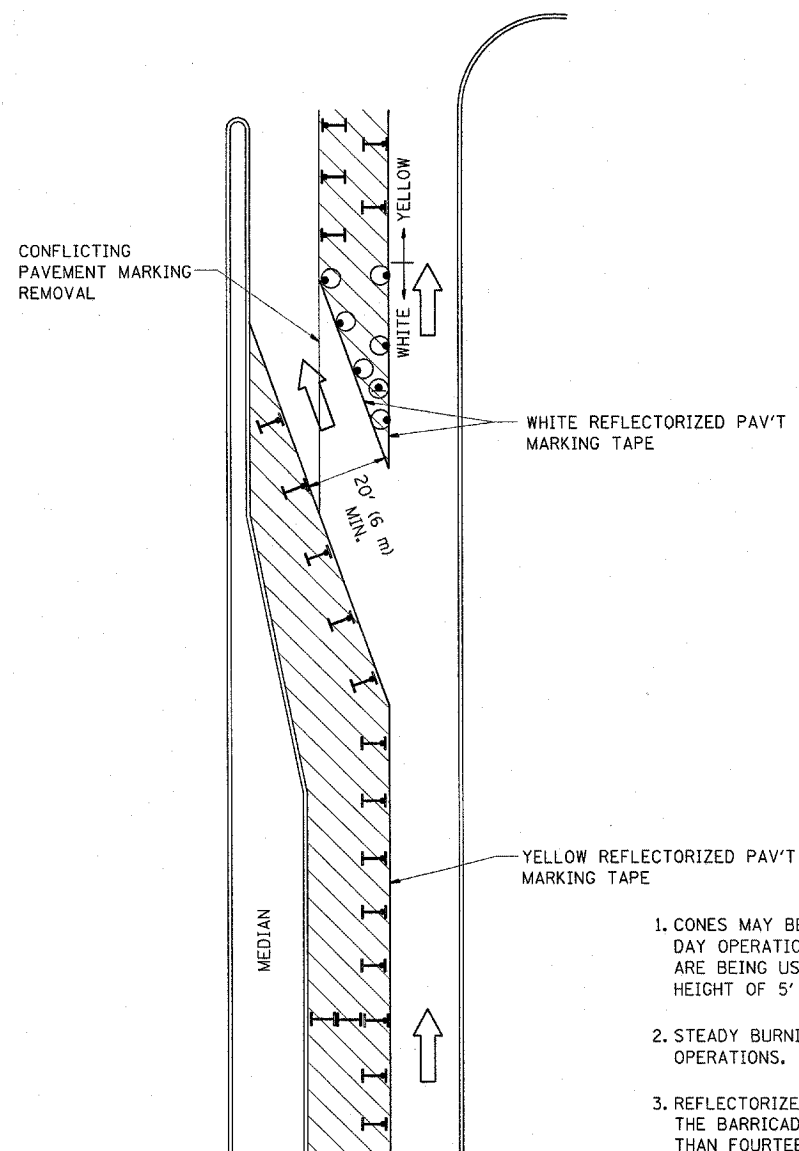





**GENERAL NOTES**

1. CONES MAY BE SUBSTITUTED FOR BARRICADES OR DRUMS AT HALF THE SPACING DURING DAY OPERATIONS. CONES SHALL BE A MINIMUM OF 28 (710) IN HEIGHT. WHEN CONES ARE BEING USED, THE "LEFT TURN LANE" SIGN MAY BE SKID MOUNTED AT A MINIMUM HEIGHT OF 5' (1.5 m).
2. STEADY BURNING LIGHTS WILL NOT BE REQUIRED ON BARRICADES OR DRUMS FOR DAY OPERATIONS. ALL LIGHTS SHALL BE MONODIRECTIONAL.
3. REFLECTORIZED TEMPORARY PAVEMENT MARKING TAPE SHALL BE PLACED THROUGHOUT THE BARRICADED AREA OF EACH TURN BAY WHERE THE CLOSURE TIME IS GREATER THAN FOURTEEN DAYS.
4. THIS APPLICATION ALSO APPLIES WHEN WORK IS BEING PERFORMED IN THE RIGHT LANE(S) AND THE RIGHT TURN BAY IS TO REMAIN OPEN. UNDER THIS CONDITION, "RIGHT TURN LANE" R3-100 24 x 24 (600 x 600) AND M6-2R 21 x 15 (530 x 380) SHALL BE USED.
5. THESE CONTROLS SHALL SUPPLEMENT MAINLINE TRAFFIC CONTROL FOR LANE CLOSURES.
6. LONGITUDINAL DIMENSIONS MAY BE ADJUSTED TO FIT FIELD CONDITIONS.
7. FORM OPER 725 IS REQUIRED.
8. IF A DRUM OR TYPE II BARRICADE WITH AN ATTACHED SIGN PANEL WHICH MEETS NCHRP 350 REQUIREMENTS IS NOT AVAILABLE, THE SIGNS SHALL BE MOUNTED, ABOVE THE BARRICADES, ON SEPARATE SIGNS SUPPORTS THAT MEET NCHR 350 PREQUIREMENTS.
9. TRAFFIC CONTROL AND PROTECTION AT TURN BAYS (TO REMAIN OPEN TO TRAFFIC) SHALL BE INCLUDED IN THE COST SPECIFIED TRAFFIC CONTROL STANDARDS OR ITEMS.

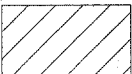
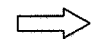
All dimensions are in inches (millimeters) unless otherwise shown.

**LEGEND**

-  WORK AREA
-  LANE OPEN TO TRAFFIC
-  TYPE I OR II BARRICADE WITH STEADY BURN LIGHT
-  DRUM WITH STEADY BURN LIGHT
-  DRUM WITH SIGN (WITH OPTIONAL FLASHING LIGHT) SEE DETAIL
-  TYPE I OR II CHECK BARRICADE WITH FLASHING LIGHT

FILE NAME =	USER NAME = rosierjm	REVISED - T. RAMMACHER 09-08-94	REVISED - R. BORO 09-14-09
ct:\pw\work\PIWIDOT\ROSIEREJM\d0159113\Dis	Std.dgn	REVISED - A. HOUSEH 11-07-95	REVISED -
	PLOT SCALE = 50.0000 // IN.	REVISED - A. HOUSEH 10-12-96	REVISED -
	PLOT DATE = 3/17/2010	REVISED - T. RAMMACHER 01-06-00	REVISED -

**STATE OF ILLINOIS  
DEPARTMENT OF TRANSPORTATION**

**TRAFFIC CONTROL AND PROTECTION AT TURN BAYS  
(TO REMAIN OPEN TO TRAFFIC)**

SCALE: NONE SHEET NO. 1 OF 1 SHEETS STA. TO STA.

F.A.U. RTE.	SECTION	COUNTY	TOTAL SHEETS	SHEET NO.
3537	3264 RS-7	COOK	22	18
TC-14			CONTRACT NO. 60161	
FED. ROAD DIST. NO. 1 ILLINOIS FED. AID PROJECT				

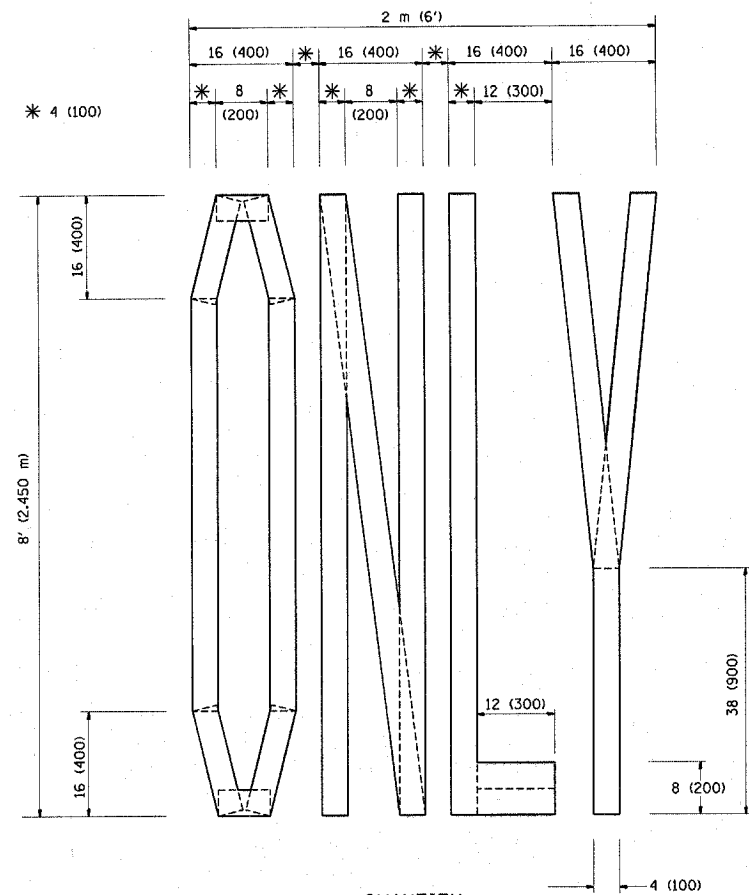

QUANTITY  
 4 (100) LINE = 64.1 ft. (19.7 m)  
 21.1 sq. ft. (1.97 sq. m)

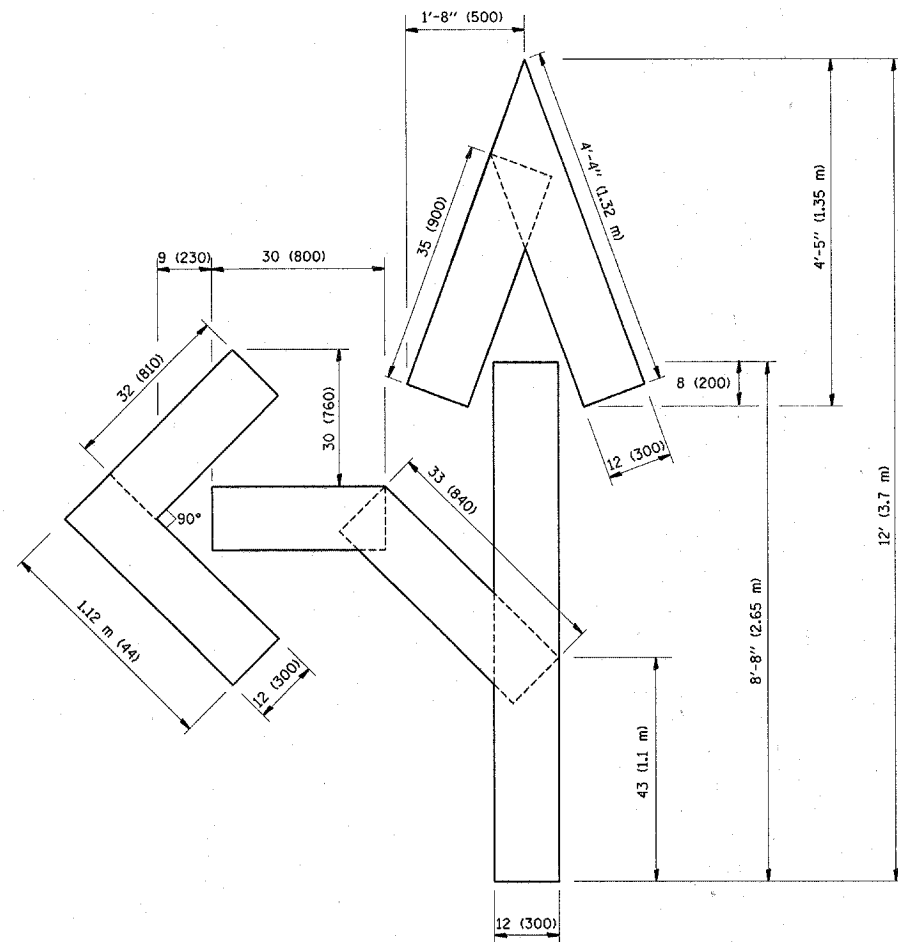

QUANTITY  
 4 (100) LINE = 82.5 ft. (25.3 m)  
 27.5 sq. ft. (2.53 sq. m)

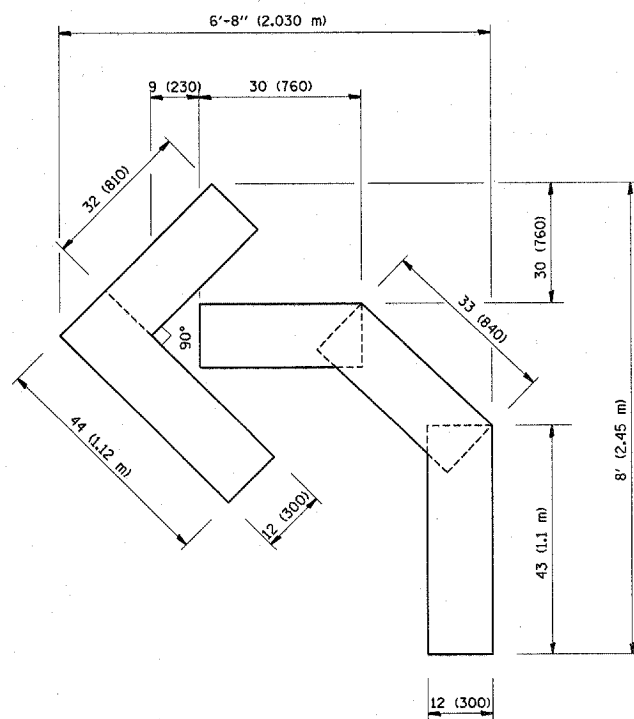

QUANTITY  
 4 (100) LINE = 45.5 ft. (13.9 m)  
 15.2 sq. ft. (1.39 sq. m)

All dimensions are in inches (millimeters) unless otherwise shown.

FILE NAME =	USER NAME = rosierem	DESIGNED -	REVISED - T. RAMMACHER 06-05-96
cr:\pwork\p\1007\ROSTIEREJM\0159113\01-Std.dgn		DRAWN -	REVISED - T. RAMMACHER 11-04-97
PLOT SCALE = 50.0000" / IN.		CHECKED -	REVISED - T. RAMMACHER 03-02-98
PLOT DATE = 3/17/2010		DATE - 09-18-94	REVISED - E. GOMEZ 08-28-00

STATE OF ILLINOIS  
 DEPARTMENT OF TRANSPORTATION

PAVEMENT MARKING LETTERS AND SYMBOLS  
 FOR TRAFFIC STAGING

SCALE: NONE SHEET NO. 1 OF 1 SHEETS STA. TO STA.

F.A.U. RTE.	SECTION	COUNTY	TOTAL SHEETS	SHEET NO.
3537	3264 RS-7	COOK	22	19
TC-16			CONTRACT NO. 60161	
FED. ROAD DIST. NO. 1 ILLINOIS FED. AID PROJECT				

SIGNING FOR FLAGGING OPERATIONS AT WORK ZONE OPENINGS

WORK ZONE EXIT OPENING

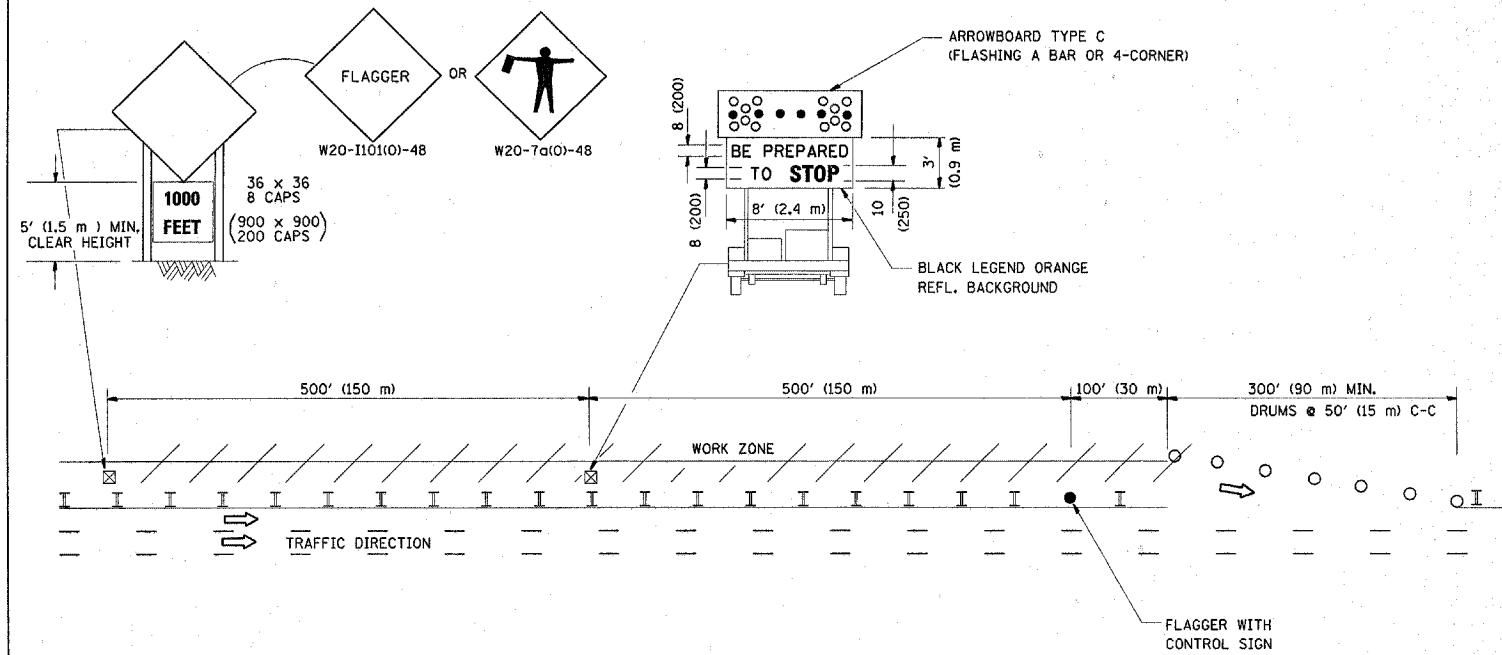

WORK ZONE ENTRY OPENING

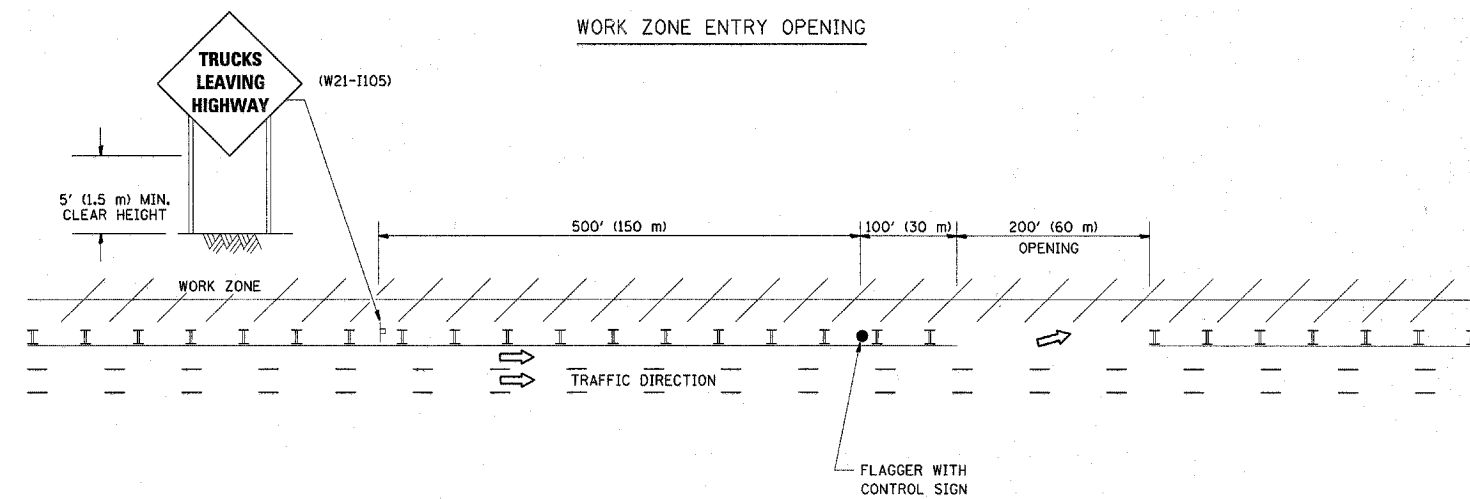

NOTES:

1. THE ARROWBOARD, THE FLAGGER AHEAD SIGN AND THE TRUCKS LEAVING HIGHWAY SIGN SHALL BE REMOVED OR TURNED AWAY FROM TRAFFIC AND THE EXIT AND ENTRY OPENINGS SHALL BE CLOSED WHEN THE FLAGGING OPERATION CEASES. NON OPERATING EQUIPMENT SHALL COMPLY WITH ARTICLE 701.11
2. WORK ZONE EXIT OPENINGS SHOULD BE A MINIMUM OF ONE HALF MILE APART.
3. EXITING THE WORK ZONE AT ANY PLACE OTHER THAN AT A WORK ZONE EXIT OPENING WILL BE PROHIBITED.
4. ALL VEHICLES SHALL ENTER THE WORK ZONE AT ENTRY OPENINGS, USING THEIR TURN SIGNALS TO WARN MOTORISTS

ALL DIMENSIONS ARE IN INCHES (MILLIMETERS) UNLESS OTHERWISE SHOWN

FILE NAME =	USER NAME = rosierj	DESIGNED -	REVISED - J.A.F. 04-03
ci:\pw_work\PIWIDOT\ROSIEREJM\d0159113\Di	Std.dgn	DRAWN -	REVISED - J.A.F. 02-06
	PLOT SCALE = 50.0000 / IN.	CHECKED -	REVISED - S.P.B. 01-07
	PLOT DATE = 3/17/2010	DATE -	REVISED - S.P.B. 12-09

STATE OF ILLINOIS  
DEPARTMENT OF TRANSPORTATION

SIGNING FOR FLAGGING OPERATIONS  
AT WORK ZONE OPENINGS

SCALE: NONE SHEET NO. 1 OF 1 SHEETS STA. TO STA.

F.A. RTE.	SECTION	COUNTY	TOTAL SHEETS	SHEET NO.
3537	3264 RS-7	COOK	23	19 A
TC-18		CONTRACT NO. 60161		
FED. ROAD DIST. NO. 1 ILLINOIS FED. AID PROJECT				

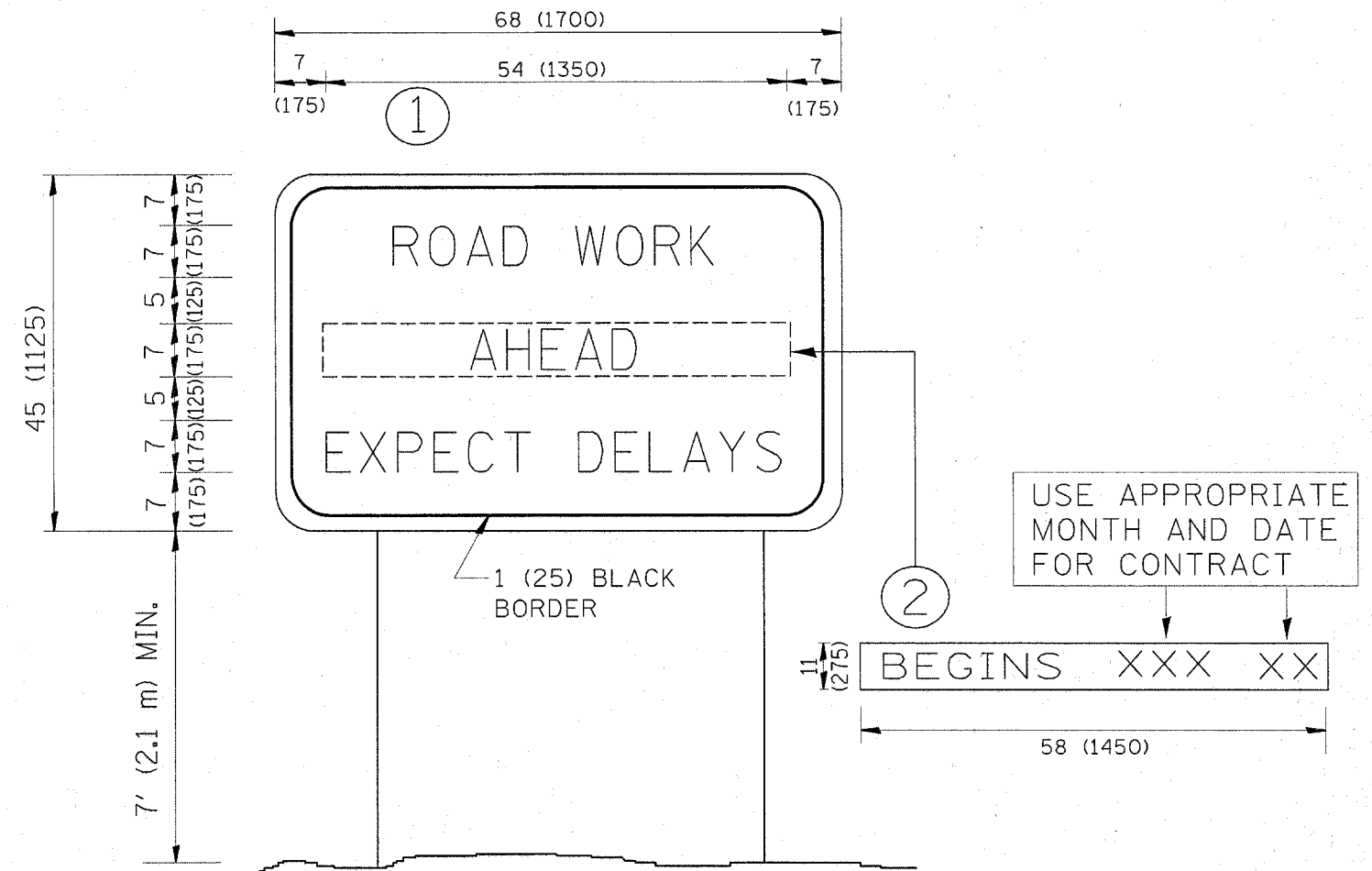

**NOTES:**

1. USE BLACK LETTERING ON ORANGE BACKGROUND.
2. ERECT SIGNS IN ADVANCE OF THE LOCATION FOR THE "ROAD CONSTRUCTION AHEAD" SIGN AT LOCATIONS AS DIRECTED BY THE ENGINEER.
3. ERECT SIGN ① WITH INSTALLED PANEL ② ONE WEEK PRIOR TO THE START OF CONSTRUCTION.
4. REMOVE PANEL ② SOON AFTER THE START OF CONSTRUCTION.
5. SEE SPECIAL PROVISION FOR "TEMPORARY INFORMATION SIGNING" FOR ADDITIONAL INFORMATION.
6. ONE SIGN ASSEMBLY EQUALS 25.70 SQ. FT. (2.3 SQ. M.)
7. SHALL BE PAID FOR AS TEMPORARY INFORMATION SIGNING.

ALL DIMENSIONS ARE IN INCHES (MILLIMETERS) UNLESS OTHERWISE SHOWN.

FILE NAME =	USER NAME = rosierejm	DESIGNED -	REVISED - R. MIRS 09-15-97
ci:\pr_work\p1001\ROSIEREJM\d0159113\DrawStd.dgn		DRAWN -	REVISED - R. MIRS 12-11-97
	PLOT SCALE = 50.0000' / IN.	CHECKED -	REVISED - T. RAMMACHER 02-02-99
	PLOT DATE = 3/17/2010	DATE -	REVISED - C. JUCIUS 01-31-07

**STATE OF ILLINOIS  
DEPARTMENT OF TRANSPORTATION**

**ARTERIAL ROAD  
INFORMATION SIGN**

SCALE: NONE SHEET NO. 1 OF 1 SHEETS STA. TO STA.

F.A.U. RTE.	SECTION	COUNTY	TOTAL SHEETS	SHEET NO.
3537	3264 RS-7	COOK	22	20
TC-22			CONTRACT NO. 60161	
FED. ROAD DIST. NO. 1 ILLINOIS FED. AID PROJECT				

## LOOP DETECTOR NOTES

- EACH PAIR OF LOOP WIRES SHALL BE PLACED IN A SEPARATE EMPTY COILABLE NONMETALLIC CONDUIT FROM THE EDGE OF PAVEMENT TO THE HANDHOLE. SPACING BETWEEN THE HOLES DRILLED IN THE PAVEMENT SHALL NOT BE LESS THAN 6" (150 mm). EMPTY COILABLE NONMETALLIC CONDUIT SHALL BE INCLUDED IN THE COST OF THE LOOP WIRE.
- THE NUMBER OF LOOP TURNS SHALL BE AS RECOMMENDED BY THE AMPLIFIER MANUFACTURER. ALL ADJACENT SIDES OF THE LOOPS SHALL BE INSTALLED IN SUCH A WAY THAT THE CURRENT FLOW IS IN THE SAME DIRECTION TO REINFORCE ITS MAGNETIC FIELDS FOR SMALL VEHICLE DETECTION.
- EACH LOOP LEAD-IN SHALL BE IDENTIFIED AND PERMANENTLY TAGGED IN THE HANDHOLE. EACH LEAD-IN CABLE TAG SHALL INDICATE THE LOCATION OF THE LOOP, LOOP ROTATION (CLOCKWISE/COUNTERCLOCKWISE), LOOP LEAD-IN DIRECTION (IN OR OUT), LOOP CABLE NUMBER AND LOCATION IN CABINET, AND NUMBER OF TURNS IN THE DETECTOR LOOPS IN WATER PROOF INK AS INDICATED ON THE DISTRICT 1 STANDARD TRAFFIC SIGNAL DESIGN DETAIL. THE CONTRACTOR SHALL MARK LOOP LOCATIONS ON RECORD DRAWINGS AND PRESENT TO THE ENGINEER AFTER FINAL INSPECTION. LOOPS SHALL BE MARKED BY LANE AND LOOP NUMBER. SEE DETAIL BELOW.
- ALL LOOP CABLE SHALL BE FASTENED WITH PLASTIC TIE WRAP TO THE HANDHOLE HOOKS.
- IN ASPHALT PAVEMENT, LOOPS SHOULD BE PLACED IN THE BINDER AND DIVEHOLES MARKED AT THE CURB WITH A SAW-CUT. THE SAW-CUT SHALL BE CUT IN ACCORDANCE WITH LOCAL AND E.P.A. DUST CONTROL REQUIREMENTS. DETECTOR LOOP(S) SHALL NOT BE INSTALLED IN WET CONDITIONS AND THE SAW-CUTS MUST BE FREE OF DEBRIS AND RESIDUE SUCH AS DUST AND WATER WHICH IS TO BE ACHIEVED BY THE USE OF COMPRESSED AIR, WIRE BRUSHING AND HEAT DRYING ACCORDING TO SEALANT MANUFACTURER REQUIREMENTS. THE DETECTOR WIRE SHALL BE HELD IN PLACE BY THE USE OF FORM WEDGES. WEDGES SHALL BE SPACED NO MORE THAN 18" (450 mm) APART.
- LOOP SPLICES SHALL BE SOLDERED USING A SOLDERING IRON. BLOW TORCHES OR OTHER DEVICES WHICH OXIDIZE COPPER CABLE SHALL NOT BE ALLOWED FOR SOLDERING OPERATIONS. SEE DETAIL BELOW RIGHT.
- PREFORMED DETECTOR LOOPS SHALL BE USED, AS SHOWN ON THE PLANS, WHERE NEW CONCRETE PAVEMENT IS PROPOSED. THE INSTALLATION OF PREFORMED LOOPS SHALL BE IN ACCORDANCE WITH THE DISTRICT 1 SPECIFICATIONS OR AS DIRECTED BY THE ENGINEER.

### LOOP LEAD-IN CABLE TAG

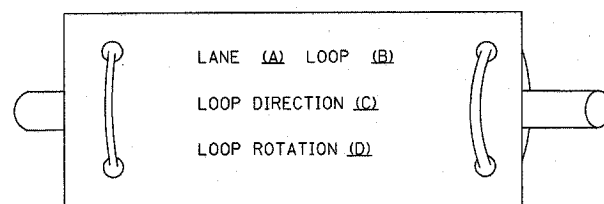

- LANE 1 IS THE LANE CLOSEST TO THE CENTERLINE OF THE ROADWAY
- LOOP #1 IS THE LOOP IN THE LANE CLOSEST TO THE INTERSECTION.
- LABEL LOOP CABLE "IN" OR LOOP CABLE "OUT".
- LABEL LOOP CABLE CLOCKWISE OR LOOP CABLE COUNTERCLOCKWISE.

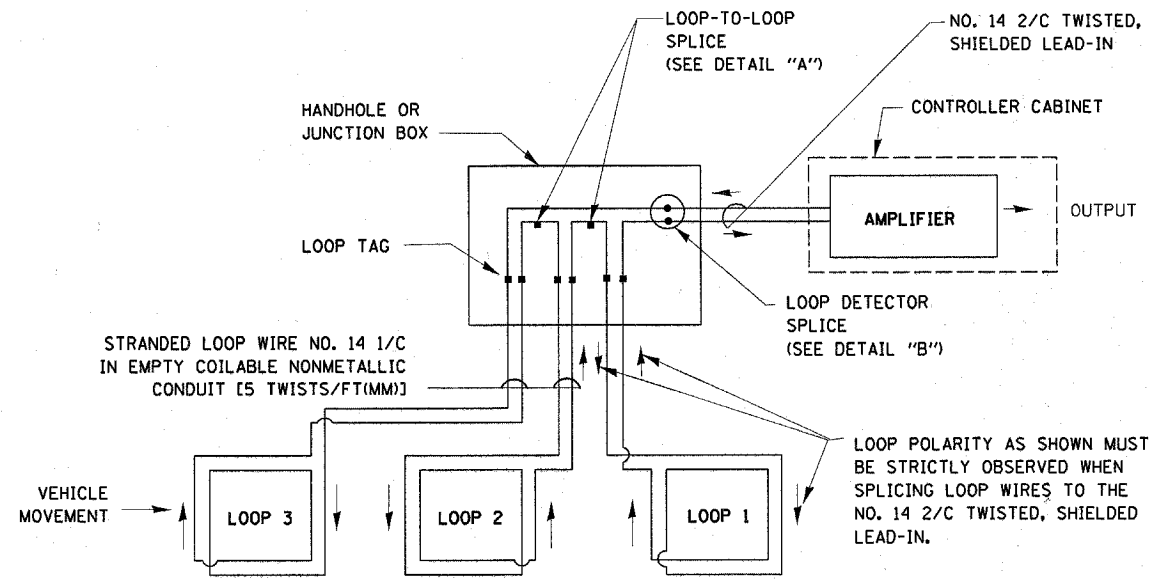

### DETECTOR LOOP WIRING SCHEMATIC

- LOOPS SHALL BE SPLICED IN SERIES.
- SAW-CUTS SHALL BE A MINIMUM WIDTH OF 5/16" (8 mm).
- SAW-CUT DEPTHS SHALL BE 3" (75 mm). IF IN CONCRETE, THE SAW-CUT DEPTH SHALL BE TO THE TOP OF THE REINFORCEMENT.
- LOOP CORNERS SHALL BE DRILLED WITH A 2" (50 mm) DIAMETER CORE.

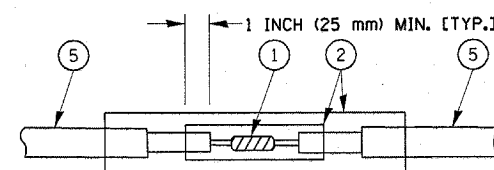

DETAIL "A"  
LOOP-TO-LOOP SPLICE

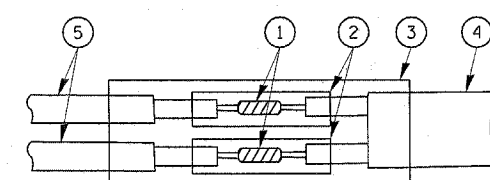

DETAIL "B"  
LOOP-TO-CONTROLLER SPLICE

### TYPE I LOOP

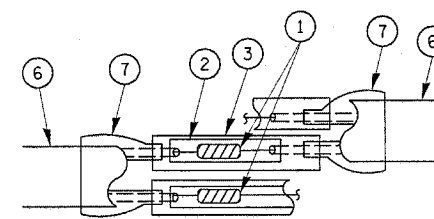

DETAIL "A"  
LOOP-TO-LOOP SPLICE

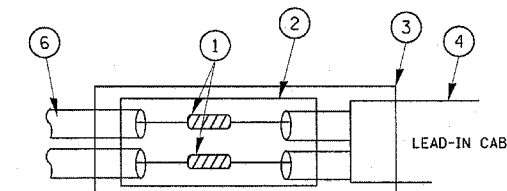

DETAIL "B"  
LOOP-TO-CONTROLLER SPLICE

### LOOP DETECTOR SPLICE

- WESTERN UNION SPLICE SOLDERED WITH ROSIN CORE FLUX. ALL EXPOSED SURFACES OF THE SOLDER SHALL BE SMOOTH.
- WCSMW 30/100 HEAT SHRINK TUBE, MINIMUM LENGTH 3" (75 mm), UNDERWATER GRADE.
- WCS 200/750 HEAT SHRINK TUBE, MINIMUM LENGTH 6" (150 mm), UNDERWATER GRADE.
- NO. 14 2/C TWISTED, SHIELDED CABLE.
- LOOP CONDUCTOR WITH FLEXIBLE PLASTIC TUBE.
- PRE-FORMED LOOP
- XL POLYOLEFIN 2 CONDUCTOR BREAKOUT SEALS, TYCO CBR-2 OR APPROVED EQUAL

**LOOPS NEXT TO SHOULDERS**

PROVIDE A PAVEMENT REPLACEMENT NOTE WHICH SHOULD EQUAL 3' (900 mm) X WIDTH OF PAVED SHOULDER.

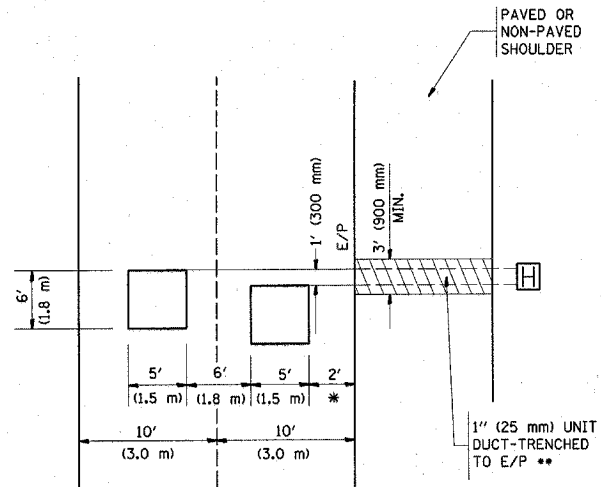

\* = (600 mm)

\*\* UNIT DUCT IS TO BE SHOWN ON PLAN SHEETS BUT SHALL NOT BE INCLUDED IN THE PAY ITEMS.

**LEFT TURN LANES WITH MEDIANS  
VOLUME DENSITY ("FAR OUT" DETECTION)  
ON SAME APPROACH  
(PROTECTED / PERMITTED LEFT TURN PHASING)**

HANDHOLE LOCATION MAY VARY DEPENDING ON GEOMETRICS AND DESIGN OF TRAFFIC SIGNALS. HEAVY-DUTY HANDHOLES TO BE USED WHEN THE MEDIAN IS MOUNTABLE. REFER TO STANDARD 814001 TO ENSURE THAT HANDHOLE FITS IN MEDIAN.

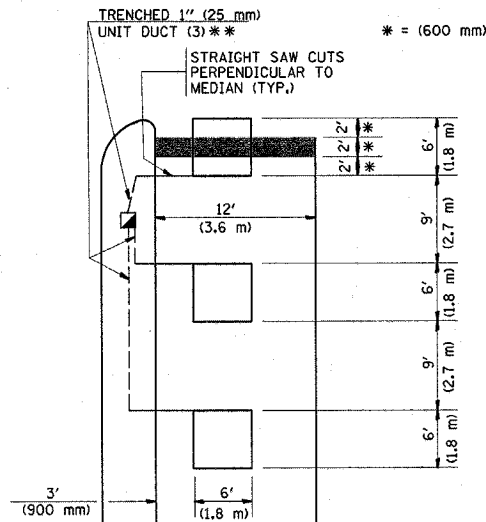

\*\* UNIT DUCT IS TO BE SHOWN ON PLAN SHEETS BUT SHALL NOT BE INCLUDED IN THE PAY ITEMS.

NOTE: DUAL LEFT TURNS NOT SHOWN REFER TO PLAN SHEET FOR DETECTOR LOOP REPLACEMENT

**LEFT TURN LANES WITHOUT MEDIANS  
VOLUME DENSITY ("FAR OUT" DETECTION)  
ON SAME APPROACH  
(PROTECTED / PERMITTED LEFT TURN PHASING)**

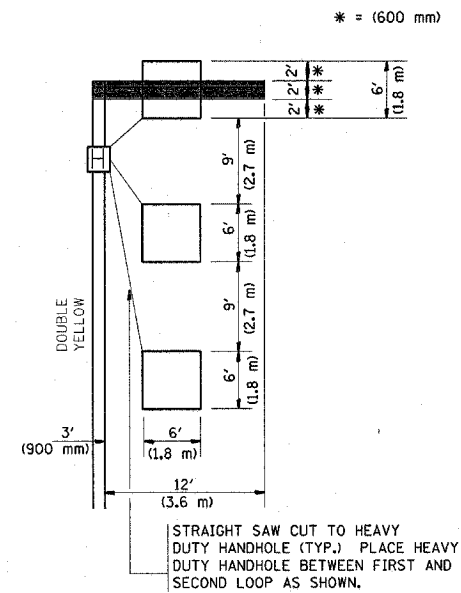

NOTE: DUAL LEFT TURNS NOT SHOWN REFER TO PLAN SHEET FOR DETECTOR LOOP REPLACEMENT

**ARTERIAL-VOLUME DENSITY ("FAR OUT" DETECTION)  
CROSS STREET-VOLUME DENSITY ("FAR OUT" DETECTION)**

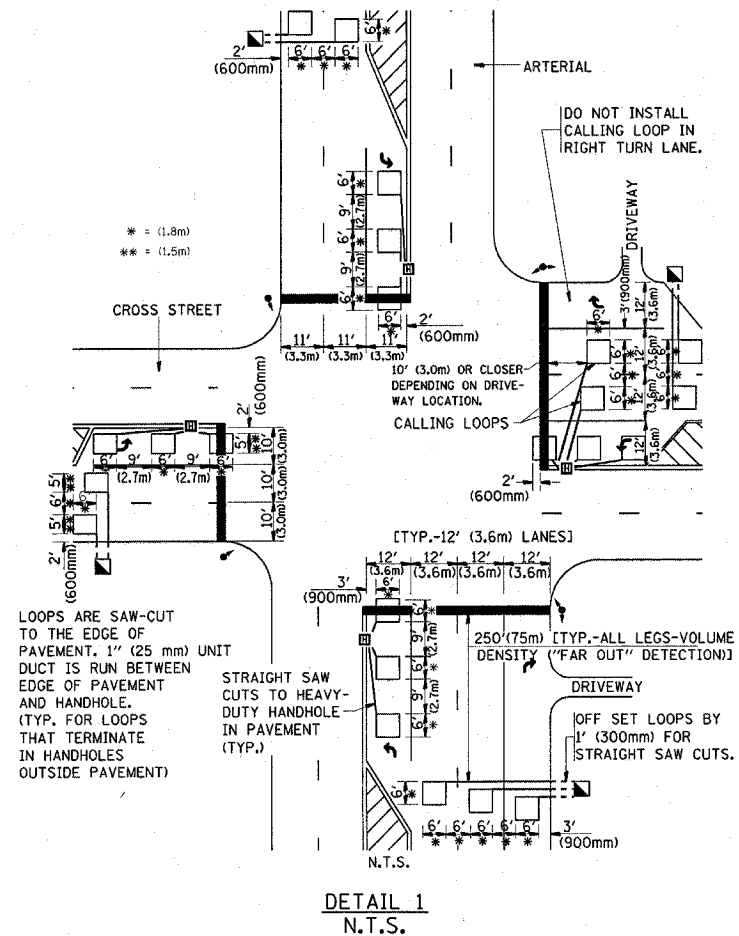

DETAIL 1  
N.T.S.

**ARTERIAL-VOLUME DENSITY ("FAR OUT" DETECTION)  
CROSS STREET-NON VOLUME DENSITY ("UPTIGHT" PRESENCE DETECTION)**

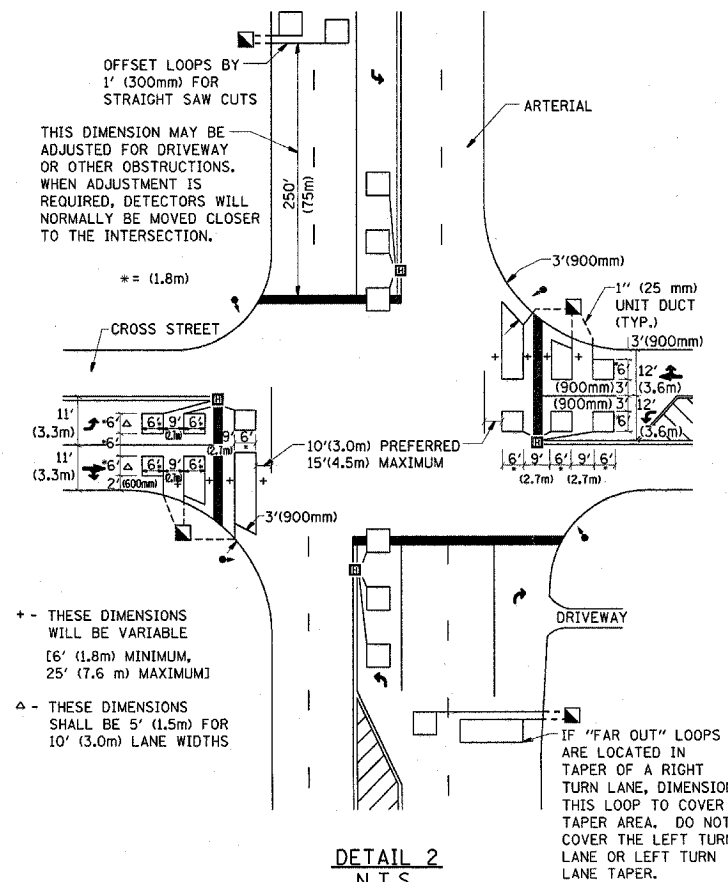

DETAIL 2  
N.T.S.

**NOTES:**

**VEHICLES LOOP DETECTORS**

- \* ALL LEAD IN CABLE SHALL BE TWO CONDUCTOR NO. 14 TWISTED, SHIELDED.
- \* EACH DETECTOR LOOP SHALL HAVE ITS OWN SAW CUT FROM THE LOOP TO THE EDGE OF PAVEMENT OR TO A HANDHOLE IN THE PAVEMENT.
- \* EACH DETECTOR LOOP SHALL HAVE ITS OWN ONE INCH (25 mm) UNIT DUCT BETWEEN THE EDGE OF PAVEMENT AND THE FIRST HANDHOLE OR JUNCTION BOX. EACH UNIT DUCT RUN SHALL BE SHOWN ON THE PLANS BY THE DESIGNER, BUT SHALL NOT BE PAID FOR SEPARATELY. THIS ITEM IS INCIDENTAL TO THE PAY ITEM FOR DETECTOR LOOPS.
- \* ONE DIMENSION OF ALL DETECTOR LOOPS SHALL BE SIX FEET (1.8 m)
- \* EACH LANE OF NON-LOCKING, PRESENCE DETECTION AND EACH LANE OF A DOUBLE LEFT TURN LANE REQUIRES A SEPARATE INDUCTIVE LOOP DETECTOR AND LEAD IN CABLE.
- \* WHEN NON-LOCKING, PRESENCE DETECTION IS USED, MORE THAN ONE LOOP PER LANE IS REQUIRED BEHIND THE STOP BAR (i.e. 1-1/2, 1-3/4, 2).
- \* WHEN SYSTEM LOOPS ARE REQUIRED ON AN APPROACH OF AN INTERSECTION, THE LOOPS USED FOR VOLUME DENSITY AND INTERSECTION TIMING SHALL ALSO BE USED AS SYSTEM DETECTORS. EACH ONE OF THESE TYPE OF LOOPS REQUIRES A SEPARATE TWO CONDUCTOR NO. 14 TWISTED SHIELDED CABLE AND A SEPARATE INDUCTIVE LOOP DETECTOR WHEN NEW CONTROLLERS ARE UTILIZED. THE DESIGNER SHALL LABEL THESE TYPES OF LOOPS AS "INTERSECTION AND SAMPLING (SYSTEM) DETECTORS" ON THE SIGNAL LAYOUT, THE INTERCONNECT PLAN AND THE SYSTEM CABLE PLAN. WHEN AN EXISTING CONTROLLER IS UTILIZED FOR THIS TYPE OF DETECTION, THE PAY ITEM "INDUCTIVE LOOP DETECTOR WITH SYSTEM OUTPUT" SHOULD BE USED.

**PLACEMENT OF DETECTORS**

THE FOLLOWING FIGURES REPRESENT THE MOST COMMON DETECTOR LOOP LOCATIONS AND SIZES. ADJUSTMENTS WILL BE NECESSARY FOR SPECIFIC GEOMETRIC CONSIDERATIONS.

LOCATIONS AND DEMENSIONS OF DETECTOR LOOPS ARE REQUIRED ON ALL SIGNAL LAYOUT PLAN SHEETS.

"FAR OUT" DETECTION REFERS TO LOCKING, PRESENCE TYPE DETECTION LOCATED IN THRU LANES, RIGHT TURN LANES, AND RIGHT TURN LANE TAPER AREAS (IF APPLICABLE), USUALLY 250' (75 m) IN ADVANCE OF STOP BARS. "UPTIGHT" DETECTION REFERS TO NON-LOCKING PRESENCE TYPE DETECTION LOCATED IN ALL LANES AND 10'-15' (3.0 m-4.5 m) BEHIND THE CROSSING STREET'S EDGE OF PAVEMENT EXTENDED.

**NOTE:**

ALL DETAILS AND NOTES SHOWN ARE FROM THE I.D.O.T. DISTRICT 1 TRAFFIC SIGNAL DESIGN GUIDELINES DATED JANUARY 1995

THIS DRAWING HAS BEEN PREPARED TO ASSIST THE RESIDENT ENGINEER FOR ALL ROADWAY RESURFACING OR S.M.A.R.T. PROJECTS WHERE THE DIMENSIONS ARE NOT SHOWN ON THE PLANS AND THE FINAL LOCATIONS FOR CROSSWALKS OR STOP BARS ARE NOT DETERMINED.

FILE NAME =	USER NAME = rosiere,jm	DESIGNED -	REVISED -	<b>STATE OF ILLINOIS DEPARTMENT OF TRANSPORTATION</b>	<b>DISTRICT 1 - DETECTOR LOOP INSTALLATION DETAILS FOR ROADWAY RESURFACING</b>			F.A.U. RTE.	SECTION	COUNTY	TOTAL SHEETS	SHEET NO.
std.dgn	std.dgn	DRAWN -	REVISED -					3537	3264 RS-7	COOK	22	22
PLOT SCALE = 50.0000' / IN.		CHECKED - R.K.F.	REVISED -					<b>TS-07</b>			CONTRACT NO. 60161	
PLOT DATE = 3/17/2010		DATE -	REVISED -					FED. ROAD DIST. NO. 1   ILLINOIS   FED. AID PROJECT				
				SCALE: NONE	SHEET NO. 1 OF 1 SHEETS	STA.	TO STA.					