

SIDE VIEW ESP 3 & 4 CABINET

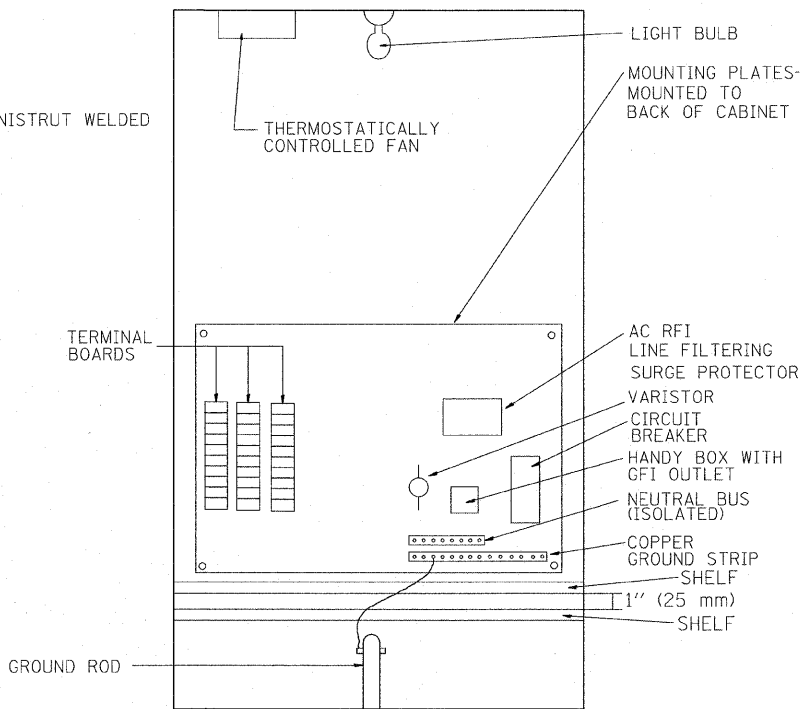

ESP 3 CABINET

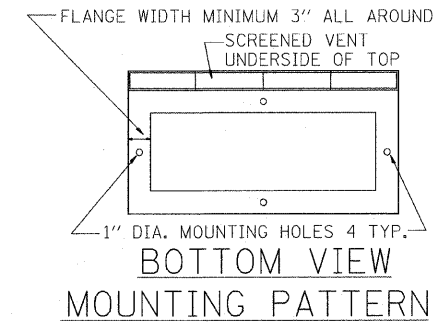

TYPICAL CABINET INTERIORS  
STANDARD TRAFFIC SYSTEMS CENTER CABINETS

TYPE	MINIMUM DIMENSIONS INSIDE					MATERIAL
	HEIGHT (IN-mm)	WIDTH (IN-mm)	DEPTH (IN-mm)	THICKNESS (IN-mm)		
ESP1	22.5" (571.5 mm)	14.25" (361.95mm)	9.75" (247.65mm)	3/16" (4.76mm)		FABRICATED ALUMINUM
ESP2	36" (914.4mm)	20" (508.0mm)	15" (381.0mm)	3/16" (4.76mm)		FABRICATED ALUMINUM
ESP3	49.5" (1.26 m)	30" (762.0mm)	17" (431.8mm)	3/16" (4.76mm)		FABRICATED ALUMINUM
ESP4	55" (1.4 m)	44" (1.12 m)	26" (660.4mm)	3/16" (4.76mm)		FABRICATED ALUMINUM

NOTES:

- CABINETS, CABINET POSTS AND CABINET PEDESTALS SHALL BE PRIMED AND PAINTED IN ACCORDANCE WITH SECTION T637 OF THE "STANDARD SPECIFICATIONS FOR TRAFFIC CONTROL ITEMS". THE FINAL COAT SHALL BE (X) IN COLOR. THE INTERIOR SHALL BE PAINTED WHITE. SIGNAL POSTS AND HEADS TO BE FEDERAL YELLOW 89-19(MAUTZ).
- CABINETS SHALL BE INSTALLED IN ACCORDANCE WITH APPLICABLE PORTIONS OF SECTION T400 OF THE "STANDARD SPECIFICATIONS FOR TRAFFIC CONTROL ITEMS".
- ALL CABINETS WHICH ARE SERVICED BY 117 VOLTS A.C. POWER SHALL BE EQUIPPED WITH A 10 AMP CIRCUIT BREAKER, A.C. R.F.I. LINE FILTERING SURGE PROTECTOR, VARISTOR, AS INCIDENTAL TO THE COST OF THE CABINET. CMS CABINETS TYPE IV SHALL HAVE A 60 AMP. CIRCUIT BREAKER MINIMUM.
- ESP 2/3/4 CABINETS SHALL BE FITTED WITH A THERMOSTATICALLY CONTROLLED FAN. IT SHALL BE MOUNTED AT THE TOP OF THE CABINET. THE FAN SHALL BE CAPABLE OF OPERATING AT 130 CPM AT 160' (48.8 m) OF STATIC WATER PRESSURE. A PORCLAIN BASED PULL CHAIN FIXTURE WITH 3 PRONG OUTLET SHALL ALSO BE PROVIDED.
- RAMP METERING ESP 3 TYPE CABINETS SHALL ALSO BE EQUIPPED WITH A LOAD RELAY AND 2 CIRCUIT FLASHER. LAMPS, FAN, LOAD RELAY, AND 2 CIRCUIT FLASHER SHALL BE INCIDENTAL TO THE COST OF THE CABINET
- INCIDENTAL TO THE COST OF EACH CABINET THE CONTRACTOR SHALL CONSTRUCT A 5 INCH (130mm) PCC SIDEWALK OF A RECTANGULAR AREA 3 FEET (915 mm) BY 4 FEET (1.25 m) IMMEDIATELY ADJACENT TO THE CABINET FOUNDATION ON THE SAME SIDE OF THE FOUNDATION AS THE CABINET DOOR TO PROVIDE FOOTING DURING INSTALLATION AND MAINTENANCE.
- ANCHOR BOLTS FOR PEDESTAL AND BASE MOUNTED CABINETS SHALL BE CONSIDERED INCIDENTAL TO THE COST OF THE CABINET.
- ALL CABINETS SHALL HAVE TERMINAL BLOCKS AND SHELVES AS SHOWN. THESE ITEMS SHALL BE CONSIDERED INCIDENTAL TO THE COST OF THE CABINET.
- THE CABINET DOOR SHALL BE HINGED ON THE RIGHT SIDE WHEN FACING THE CABINET. THE DOOR SHALL BE FURNISHED WITH A GASKET THAT SHALL FORM A WEATHER TIGHT SEAL BETWEEN THE CABINET AND DOOR. THE HINGES SHALL BE CONTINUOUS AND BOLTED TO THE CABINET AND DOOR UTILIZING 1/4-20 STAINLESS STEEL CARRIAGE BOLTS AND NY-LOCK NUTS. THE HINGES WILL BE MADE OF STAINLESS STEEL WITH A 0.25 INCH (6.35 mm) DIAMETER STAINLESS STEEL HINGE PIN. THE HINGE PIN SHALL BE CAPPED TOP AND BOTTOM BY WELD TO RENDER IT TAMPER PROOF.
- THE LATCHING MECHANISM SHALL BE A 3 POINT DRAW ROLLER TYPE. THE CENTER CATCH AND PUSHRODS SHALL BE EITHER CADMIUM OR ZINC PLATED, TYPE II CLASS I. PUSHRODS WILL BE TURNED EDGEWISE AT THE OUTWARD SUPPORTS AND SHALL BE 0.25 INCH (6.35 mm) BY 0.75 INCH (19.05 mm), MINIMUM. ROLLERS SHALL HAVE A MINIMUM DIAMETER OF 0.875 INCH (22.22 mm) AND WILL BE MADE OF NYLON. THE CENTER CATCH SHALL BE FABRICATED FROM 0.14 INCH (3.55 mm) STEEL, MINIMUM. WHEN THE DOOR IS CLOSED AND LATCHED, IT WILL BE LOCKED. THE LATCHING HANDLE SHALL HAVE A PROVISION FOR PADLOCKING IN THE CLOSED POSITION. AN OPERATING HANDLE SHALL BE FURNISHED WITH EACH LOCK. THE HANDLE WILL BE STAINLESS STEEL WITH A 0.75 INCH (19.05 mm) DIAMETER SHANK.
- THE ENCLOSURE SHALL BE EQUIPPED WITH TWO ADJUSTABLE "C" MOUNTING CHANNELS WELDED ON BOTH SIDE WALLS AND BACK WALL OF THE ENCLOSURE, ALLOWING VERSATILE POSITIONING OF SHELVES OR PANELS. MOUNTING CHANNELS SHALL BE FACTORY PAINTED SAME COLOR AS INTERIOR OF CABINET.
- CABINET DOOR SHALL NOT HAVE COMPARTMENT DOORS OR LOUVERS.
- ALL FIELD CABINETS SHALL BE FITTED WITH BRASS LOCKS.
- ESP TYPE 2 & 3 CABINETS FITTED WITH TWO SHELVES AS SHOWN.
- POST TOP MOUNTED CABINETS, SHALL HAVE A 0.25 INCH (6.3 mm) BOTTOM OF CABINET WELDED.
- THE CONTROL CABINET SHALL BE SET PLUMB ON THE FOUNDATION AND FASTENED TO THE ANCHOR BOLTS WITH NUTS AND WASHERS. FLAT WASHERS SHALL BE INSTALLED BELOW AND ABOVE THE BASE PLATE OF THE CONTROL CABINET. LOCKWASHERS SHALL BE INSTALLED ON TOP OF THE TOP FLAT WASHER.

- (X)
- |                  |                     |
|------------------|---------------------|
| EDENS            | WALNUT *            |
| KENNEDY          | BLUE STREAK **      |
| EISENHOWER       | CARIBBEAN BLUE *    |
| I-290/I153/I-355 | POST OFFICE BLUE ** |
| RYAN             | YELLOW STONE II **  |
| I-55             | MEDIUM BRONZE *     |
| I-57             | RED BARON **        |
| CAL-KING         | BLUE STREAK **      |
| LAKE SHORE DR.   | GREEN *             |
| I-80             | STATUARY BRONZE **  |
- ALL RAMP METERING CABINETS LIME GREEN \*\*\*. ALL POSTS, T.S. HEADS AND SERVICES WILL BE PAINTED FEDERAL YELLOW.  
 \* MORTON POWDER PAINT COLOR OR EQUIVALENT.  
 \*\* O'BRIEN POWDER PAINT COLOR OR EQUIVALENT.  
 \*\*\* BENJAMIN MOORE ENAMEL COLOR OR EQUIVALENT.

NO ADDITIONAL COMPENSATION SHALL BE ALLOWED FOR CONFORMING TO COLOR REQUIREMENTS

FILE NAME = C:\d106010\155TSC\TYP.DGN	USER NAME = rdahan	DESIGNED - J.G.	REVISED -	STATE OF ILLINOIS DEPARTMENT OF TRANSPORTATION TRAFFIC SYSTEMS CENTER	CCTV CABINET DETAIL SHEET	F.A. RTE.	SECTION	COUNTY	TOTAL SHEETS	SHEET NO.	
P:\P-07-1600-12\client\TSC Plans\SUB155TSC\TYP.dgn		DRAWN - G.M.	REVISED -			SCALE: NONE	SHEET NO. OF SHEETS	STA.	TO STA.	FED. ROAD DIST. NO.	ILLINOIS FED. AID PROJECT
PLOT SCALE = #SCALE#		CHECKED - J.G.	REVISED -								
PLOT DATE = 3/18/2010		DATE - 01/25/2010	REVISED -								