

CONCRETE BARRIER, DOUBLE FACE, 42"
CONCRETE BARRIER BASE

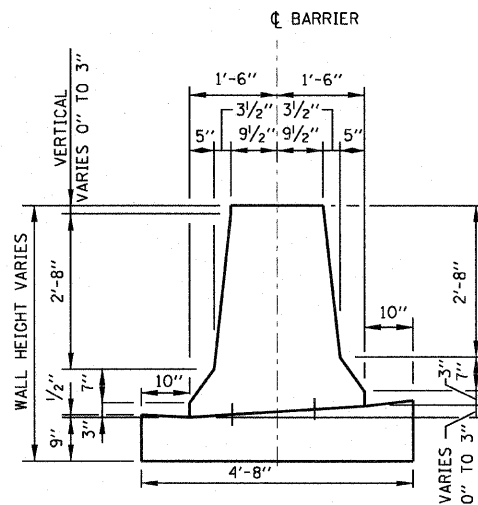

CONCRETE BARRIER,
DOUBLE FACE, VARIABLE HEIGHT
CONCRETE BARRIER BASE, VARIABLE HEIGHT

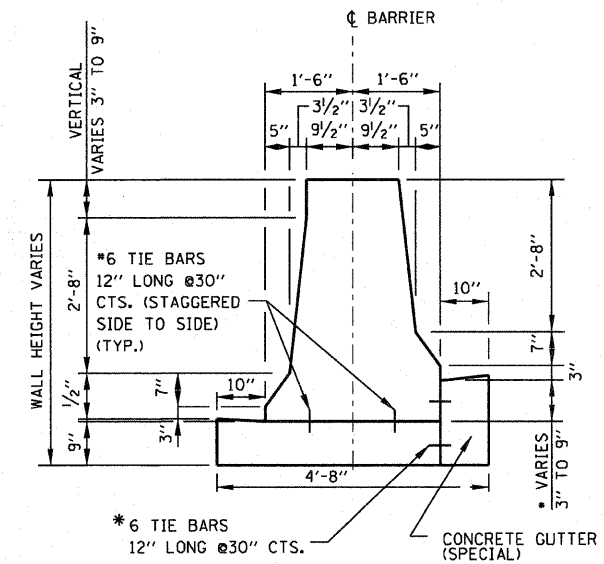

* WHEN 6" OR GREATER ADD TOP TIE BAR.

NOTES:

1. 1" DEEP CONTRACTION JOINTS SHALL BE CONSTRUCTED IN THE CONCRETE BARRIER WALL AND IN THE CONCRETE BARRIER BASE. CONTRACTION JOINTS SHALL ALSO BE CONSTRUCTED AT BOTH SIDES OF ALL DRAINAGE STRUCTURES. MAXIMUM JOINT SPACING SHALL BE 20'
2. THE FORMING OF CONTRACTION JOINTS SHALL BE DONE WITH AN APPROVED FINISHING TOOL AT THE DISCRETION OF THE ENGINEER SUBJECT TO THE SATISFACTORY CONTROL OF CRACKING. THE SAWING OF CONTRACTION JOINTS IN THE CONCRETE BARRIER WALL SHALL NOT BE PERMITTED.
3. GUTTER PROFILE IN THE VICINITY OF SAG VERTICAL CURVES, ALONG FLAT GRADES AND AT THE MEETING OF PROPOSED AND EXISTING GUTTER, SHALL BE CAREFULLY CONTROLLED AND FIELD ADJUSTED IF NECESSARY TO ENSURE POSITIVE DRAINAGE AND AVOID PONDING.
4. IN AREAS OF RELATIVELY FLAT LONGITUDINAL PROFILE GRADES, THE 3" VERTICAL DIMENSION AT THE BOTTOM OF THE BARRIER CAN VARY FROM 2" TO 3 1/4" TO CREATE AN ACCEPTABLE LONGITUDINAL GRADE IN THE GUTTER.
5. TIE BARS ARE INCIDENTAL TO THE VARIOUS BARRIER & GUTTER ITEMS AND SHALL BE EPOXY COATED.
6. WHEN ELECTRICAL OR ITS CONDUITS ARE REQUIRED THEY SHALL BE LOCATED IN THE BARRIER BASE OR IN THE EARTH BELOW THE BASE.
7. WHEN VARIABLE HEIGHT VERTICAL DIFFERENTIAL EXCEEDS 9" SEE PLAN DETAIL.

Illinois Tollway
Open Roads for a Faster Future

DATE	REVISIONS

CONCRETE BARRIER BASE AND
CONCRETE BARRIER, DOUBLE FACE,
42" AND VARIABLE HEIGHT
STANDARD C5-00

APPROVED *Jeff Daley* DATE 10-15-2007
CHIEF ENGINEER