

TYPICAL RAIL ROAD RELATED PAVEMENT MARKINGS

TYPICAL PLACEMENT OF R.R. WARNING SIGNS AND PAVEMENT MARKINGS ON COUNTY HIGHWAYS

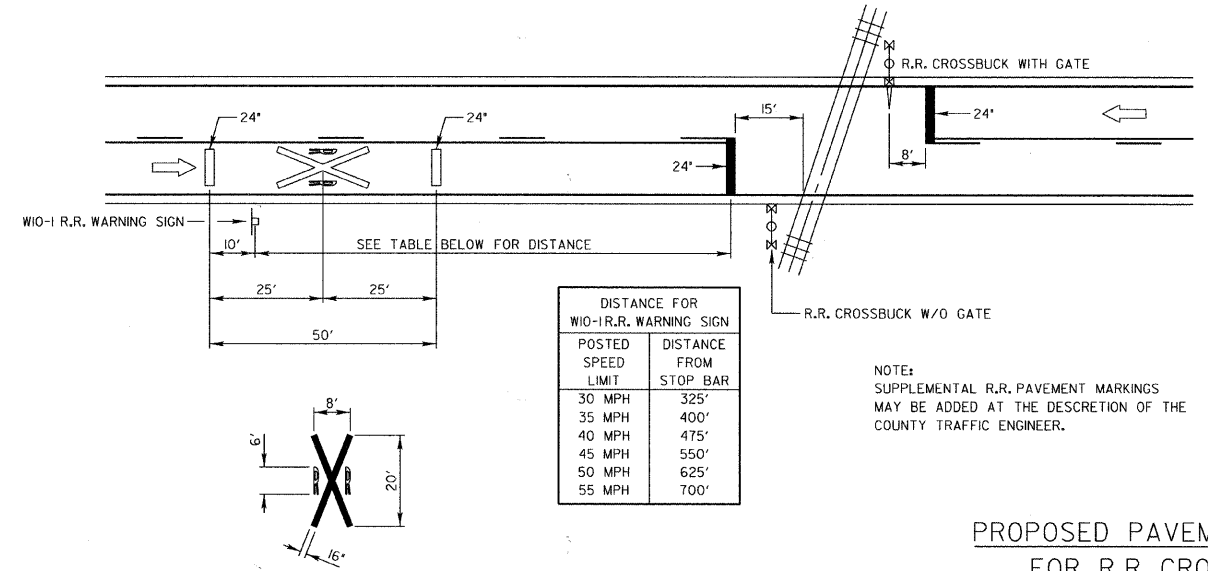

DISTANCE FOR W10-1 R.R. WARNING SIGN	
POSTED SPEED LIMIT	DISTANCE FROM STOP BAR
30 MPH	325'
35 MPH	400'
40 MPH	475'
45 MPH	550'
50 MPH	625'
55 MPH	700'

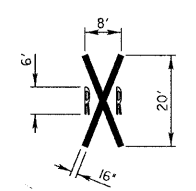

PROPOSED PAVEMENT MARKINGS FOR R.R. CROSSINGS AT SIGNALIZED INTERSECTIONS
8 FEET - 300 FEET

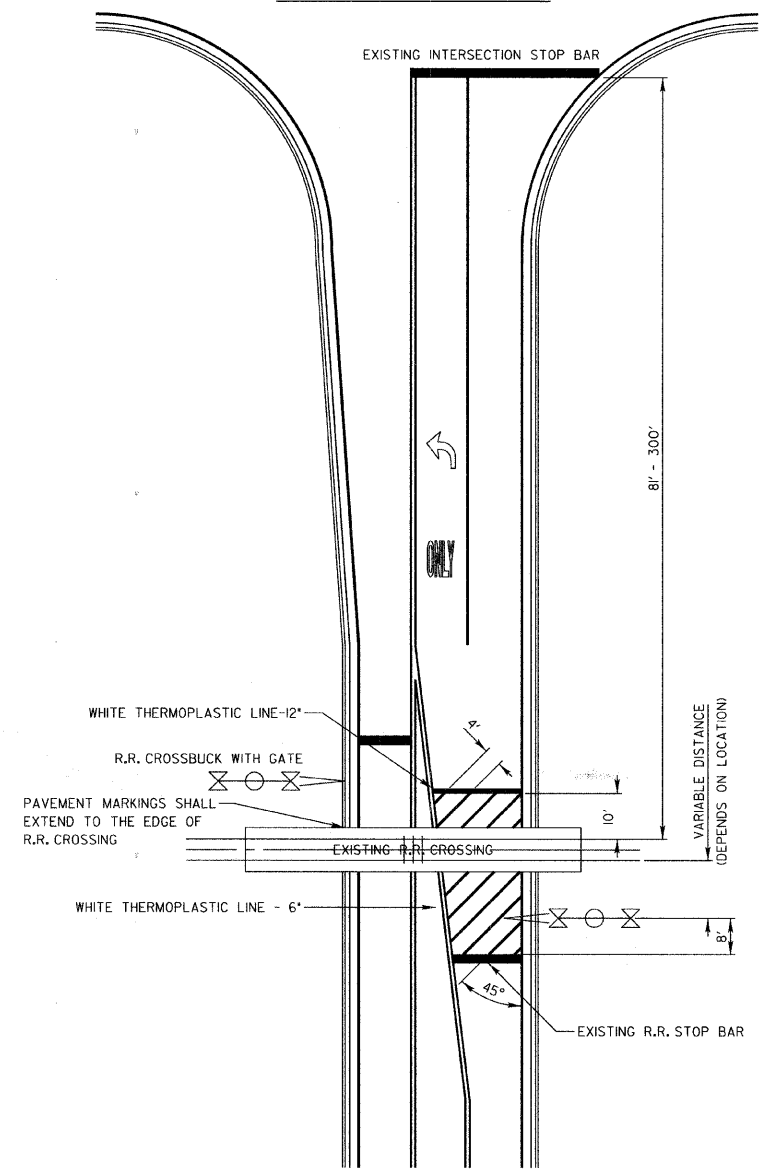

PROPOSED PAVEMENT MARKINGS FOR R.R. CROSSINGS AT SIGNALIZED INTERSECTIONS
8 FEET OR LESS

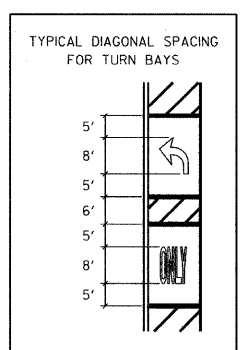
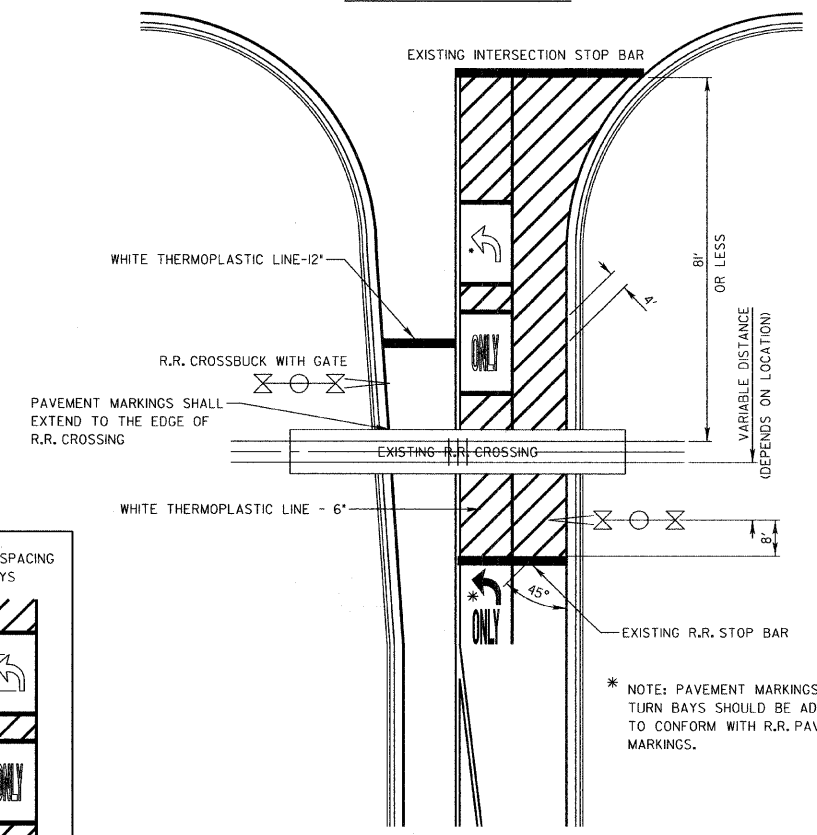

* NOTE: PAVEMENT MARKINGS FOR TURN BAYS SHOULD BE ADJUSTED TO CONFORM WITH R.R. PAVEMENT MARKINGS.

REVISIONS	DATE	APPROVED BY: A. KHAWAJA
		DATE: APRIL 1, 2007
TYPICAL PAVEMENT MARKINGS FOR RAILROAD CROSSINGS ON COUNTY HIGHWAYS		
SHEET 3 OF 3		

NO.	REVISIONS / REMARKS	DATE	BY	SURVEYOR:	DESIGNER/LIAISON:	PLOTTED BY:

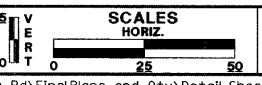

FAIRFIELD ROAD RESURFACING 2009



FAIRFIELD RD RESURFACING

ROUTE	SECTION	SECTION NUMBER	SHEET	SHEETS
CH 49	113	08-00999-01-RS	55	60