

# STAGING TYPICAL SECTIONS

STAGE I  
STAGING TYPICAL FOR PROFILE ADJUSTMENT  
SHADY OAKS RD  
BEEMERVILLE RD  
MCGIRR RD

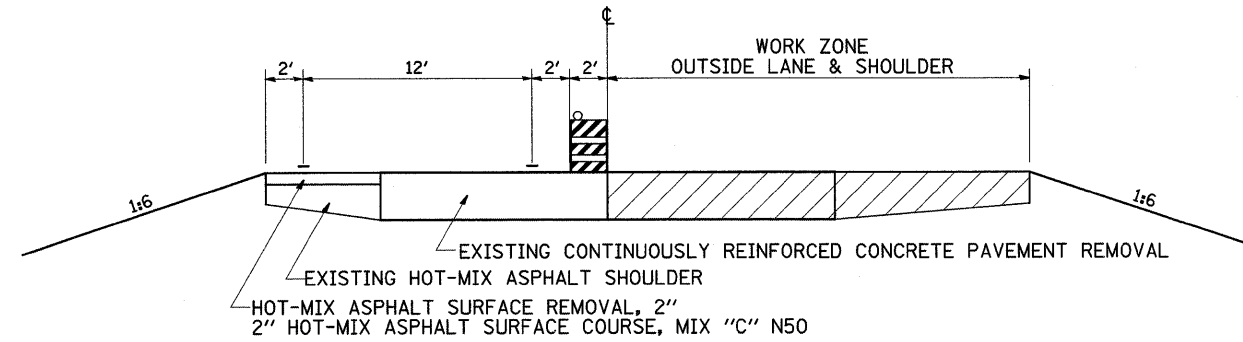

STAGE I

1. THE EXISTING INSIDE SHOULDER SHALL BE MILLED 2" AND RESURFACED PRIOR TO CLOSING THE OUTSIDE LANE.
2. THE CONTINUOUSLY REINFORCED CONCRETE PAVEMENT REMOVAL AND REPLACEMENT AND PORTLAND CEMENT CONCRETE SHOULDER REMOVAL AND REPLACEMENT SHALL BE CONSTRUCTED IN ONE DAY AND TREATED AS A PATCH TO PREVENT AN OVERNIGHT DROP OFF.

STAGE II  
STAGING TYPICAL FOR PROFILE ADJUSTMENT  
SHADY OAKS RD  
BEEMERVILLE RD  
MCGIRR RD

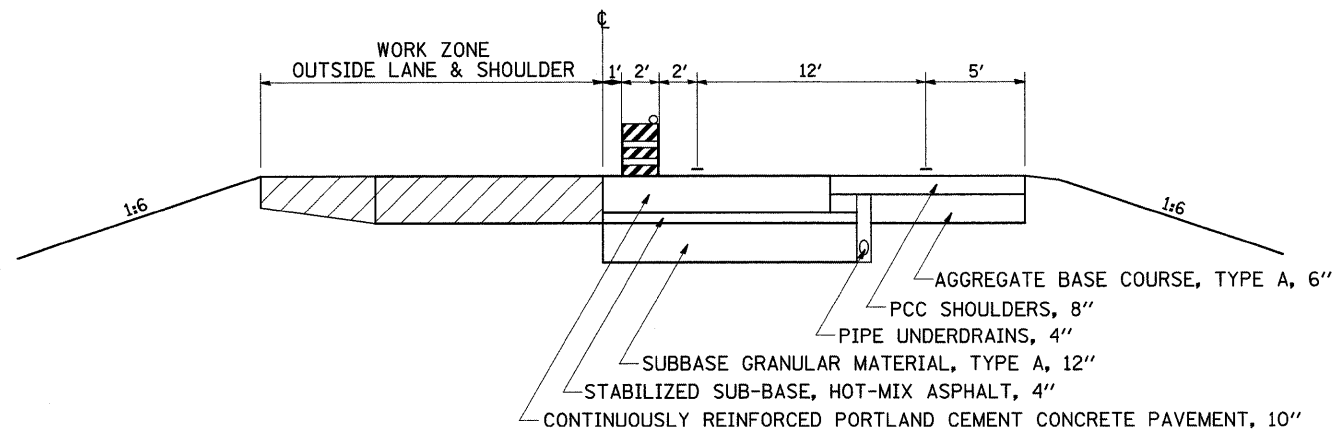

STAGE II

1. THE CONTINUOUSLY REINFORCED CONCRETE PAVEMENT REMOVAL AND REPLACEMENT AND PORTLAND CEMENT CONCRETE SHOULDER REMOVAL AND REPLACEMENT SHALL BE CONSTRUCTED IN ONE DAY AND TREATED AS A PATCH TO PREVENT AN OVERNIGHT DROP OFF.

FILE NAME =	USER NAME = dossdd	DESIGNED -	REVISED -	<b>STATE OF ILLINOIS DEPARTMENT OF TRANSPORTATION</b>	<b>I-39 STAGING TYPICAL SECTIONS</b>	F.A.I RTE.	SECTION	COUNTY	TOTAL SHEETS	SHEET NO.
et:\pw_work\PMIDOT\DOSSDD\0149531\0205029-sht-typical.dgn	PLOT SCALE = 50.0000' / IN.	DRAWN -	REVISED -			39	(103-1, 103-2)RS	LEE	313	79
PLOT DATE = Fri Mar 26 07:52:55 2010	DATE -	CHECKED -	REVISED -			CONTRACT NO. 64E97		ILLINOIS FED. AID PROJECT		
		DATE -	REVISED -			SCALE:	SHEET NO.	OF	SHEETS	STA.