

7/16" ϕ holes at 4'-0" cts. for 3/8" ϕ bolts. All bolts shall be burned, sawed, or chipped off flush with the plates after forms are removed, typ.

Place 1/2" ϕ x 6" granular or solid flux filled headed studs conforming to Article 1006.32 of the Std. Specs., automatically end welded at 1'-0" alt. cts.

SECTION THRU STRIP SEAL JOINT

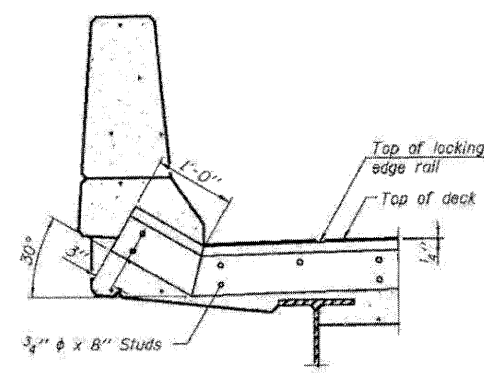

AT PARAPET
See Section A-A for end treatment of skew > 30°.

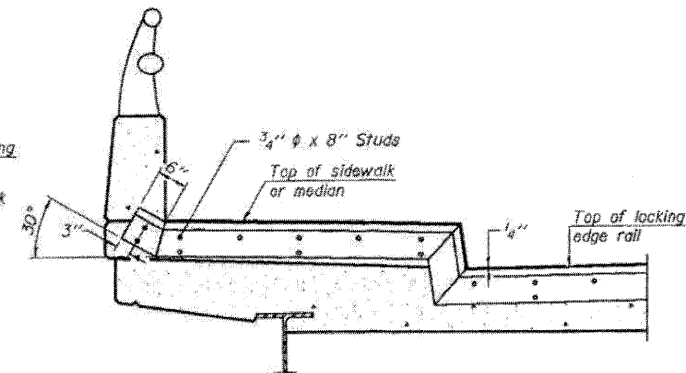

AT SIDEWALK OR MEDIAN
Shorter plates with a single row of studs at 12" cts. may be necessary on medians which are shallower than 9". See manufacturer's recommendation.

TYPICAL END TREATMENTS

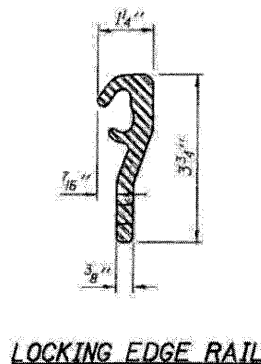

LOCKING EDGE RAIL

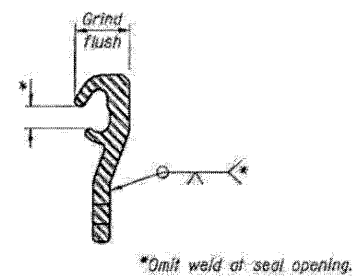

LOCKING EDGE RAIL SPLICE

*Omit weld at seal opening.

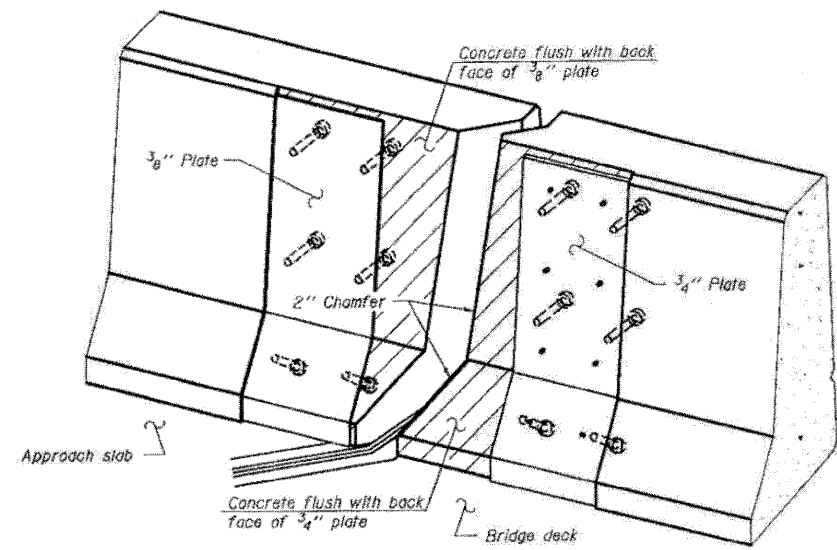

TRIMETRIC VIEW
(Showing back plates only)

Notes:
The strip seal shall be made continuous and shall have a minimum thickness of 1/4". The configuration of the strip seal shall match the configuration of the Locking Edge Rails. Open or "webbed" strip seal gland configurations are not permitted. The gland shall be sized for a maximum rated movement of 4 inches. The Locking Edge Rails depicted are conceptual only, except for the minimum dimensions shown. The actual configuration of the Locking Edge Rails and matching strip seal may vary from manufacturer to manufacturer. Flanged edge rails will not be allowed. Locking Edge Rails may be spliced at slope discontinuities.
The manufacturer's recommended installation methods shall be followed. The joint opening and deck dimensions detailed on the superstructure are based on a rolled rail expansion joint. If the Contractor elects to use the welded rail expansion joint, the opening and deck dimensions shall be modified according to the dimensions detailed on this sheet. Required modifications shall be made at no additional cost to the State.
All steel components shall be galvanized after fabrication according to Article 520.03 of the Standard Specifications.
Maximum space between rail segments at stage lines shall be 3/16", sealed with a suitable sealant.

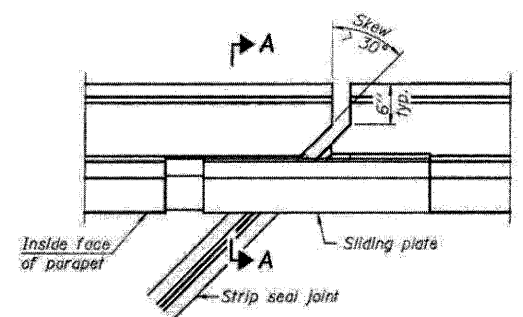

PLAN

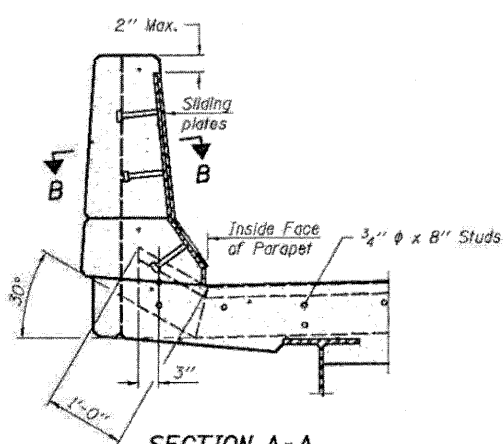

SECTION A-A
POINT BLOCK DETAILS
(for skew > 30°)

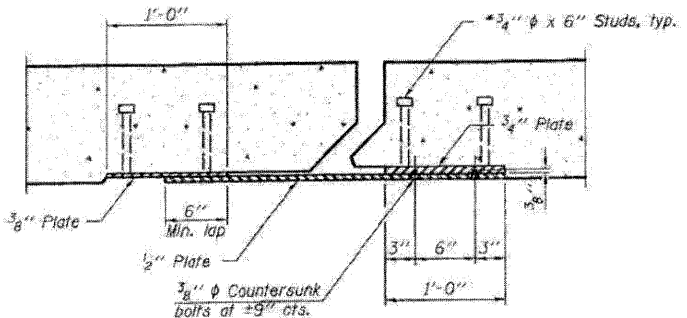

SECTION B-B

BILL OF MATERIAL

Item	Unit	Total
Preformed Joint Strip Seal	Foot	184

PREFORMED JOINT STRIP SEAL
STRUCTURE NO'S. 052-0044 (SB) & 052-0045 (NB)

FILE NAME = 0520244-64E97-27-pre1-judge
PLOT DATE = 3/29/2010
PLOT SCALE = 58.8888" / IN.

CHRISTIAN-ROGE & ASSOCIATES, INC.
ENGINEERS-PLANNERS-SURVEYORS
211 WEST WACKER DRIVE
CHICAGO, ILLINOIS 60606
PHONE: (312)372-2023 FAX: (312)372-5274

DESIGNED - B.N.S./J.C.N.
DRAWN - D.J./F.M.
CHECKED - B.N.S./J.C.N.
DATE - MARCH, 2010

STATE OF ILLINOIS
DEPARTMENT OF TRANSPORTATION

PREFORMED JOINT STRIP SEAL
SOUTHBOUND & NORTHBOUND STRUCTURES S.N. 052-0044
I-39 OVER PERRY ROAD S.N. 052-0045
SCALE: SHEET NO. S27 OF S28 SHEETS STA. TO STA.

F.A.J. RTE.	SECTION	COUNTY	TOTAL SHEETS	SHEET NO.
39	103-1, 103-2RS	LEE	313	243

CONTRACT NO. 64E97
FED. ROAD DIST. NO. ILLINOIS FED. AID PROJECT