

SECTION C-C

RETURNED END DETAIL

* Adjust this dimension when the width of the shoulders is other than 2.4 m (8').

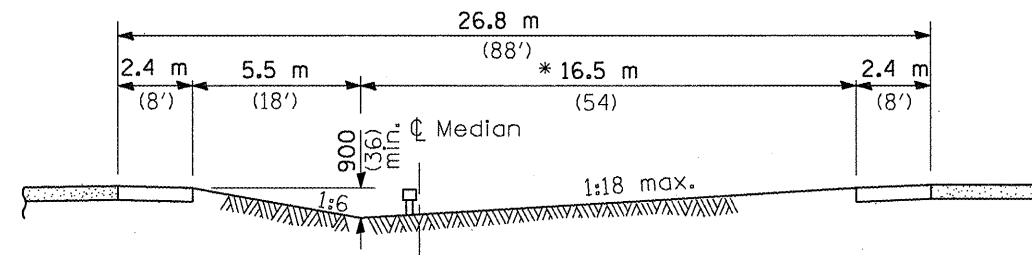

SECTION A-A

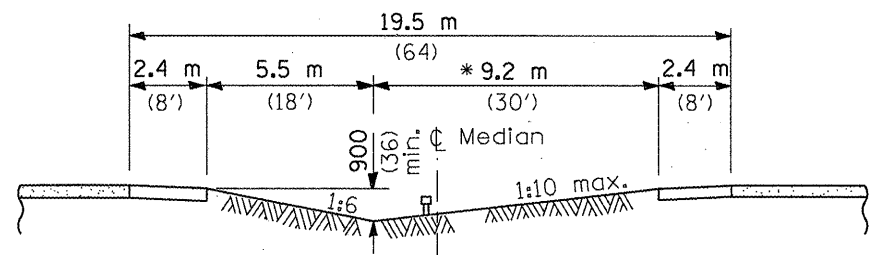

SECTION B-B

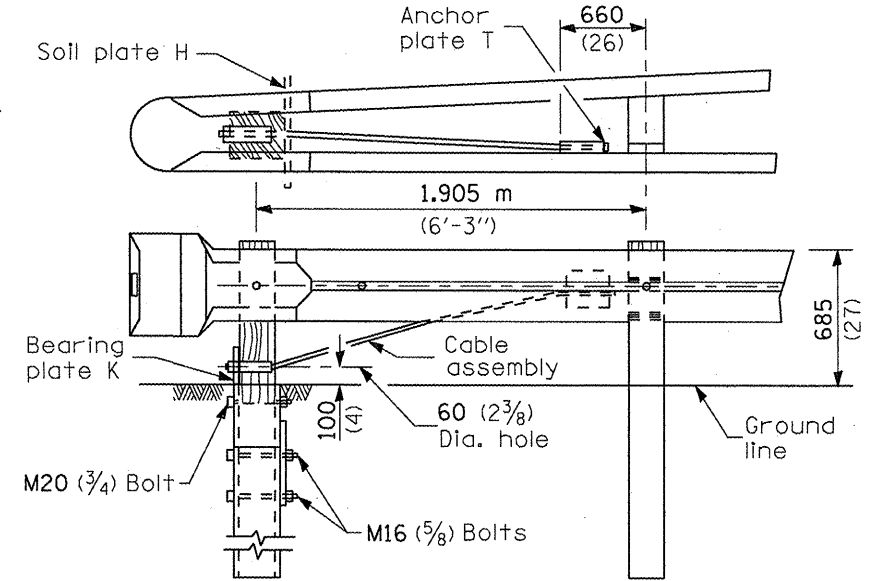

WOOD POST TUBULAR STEEL FOUNDATION

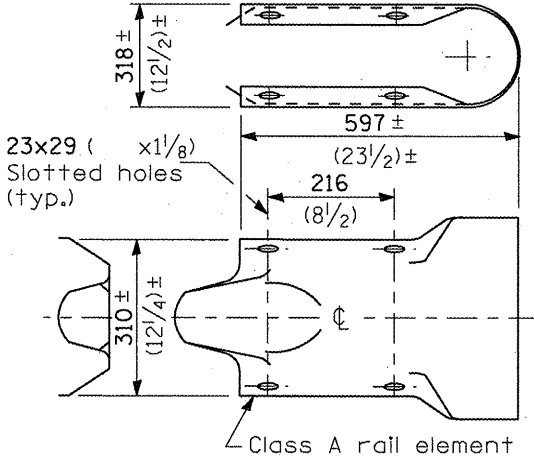

RETURN END SECTION

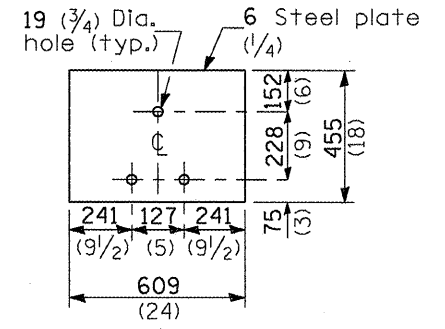

SOIL PLATE H

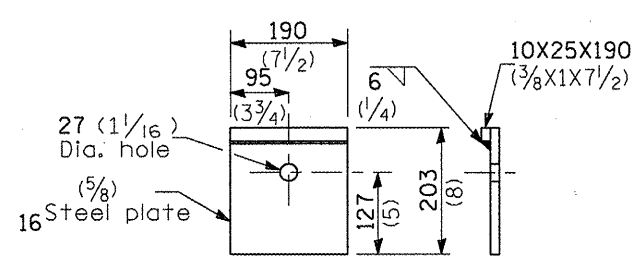

BEARING PLATE K

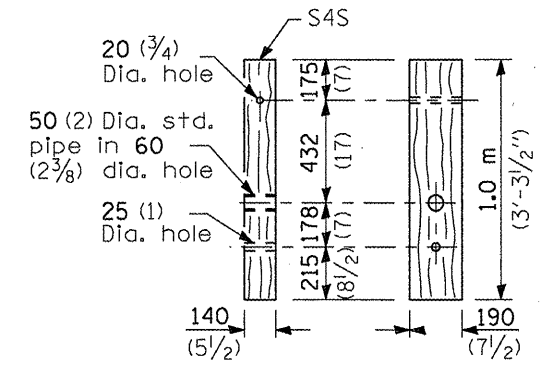

WOOD BREAKAWAY POST

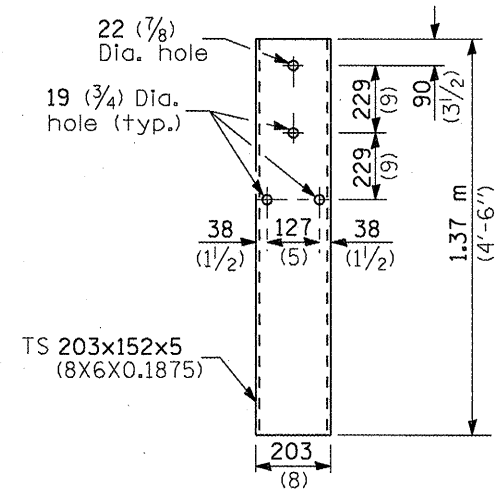

STEEL TUBE

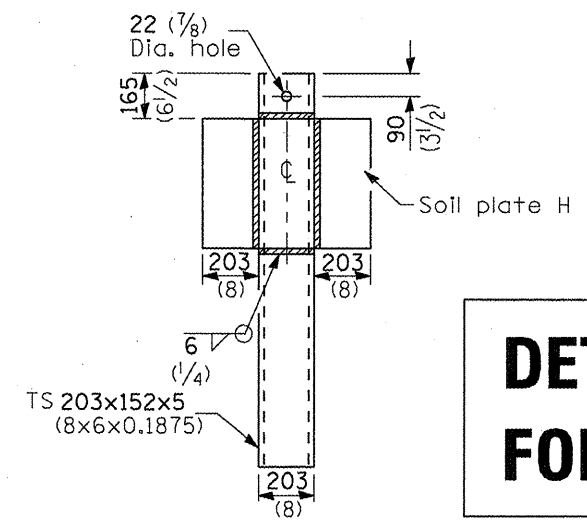

ALTERNATE SOIL PLATE CONNECTION

DETAIL INCLUDED FOR REPAIR ONLY

All dimensions are in millimeters (inches) unless otherwise shown.

FILE NAME =	USER NAME = schwankerg	DESIGNED -	REVISED -	STATE OF ILLINOIS DEPARTMENT OF TRANSPORTATION	TRAFFIC BARRIER TERMINAL TYPE 4	F.A. RTE.	SECTION	COUNTY	TOTAL SHEETS	NO.
at:\p\work\PIWIDOT\SCHWANKERG\08184951\366A25-shd-detailed.dgn	PLOT SCALE = 100.0000 / IN.	DRAWN -	REVISED -			VAR.		VAR.	36	15
PLOT DATE = Feb 17, 2010 - 03:31:12 PM	DATE -	CHECKED -	REVISED -			CONTRACT NO. 66A25				
		DATE -	REVISED -			ILLINOIS FED. AID PROJECT				
SCALE:						SHEET NO.	OF	SHEETS	STA.	TO STA.

• D-3 HIGHWAY DAMAGE REPAIR 2010