

MODIFIED THICKNESS WOOD BLOCKOUT DETAIL

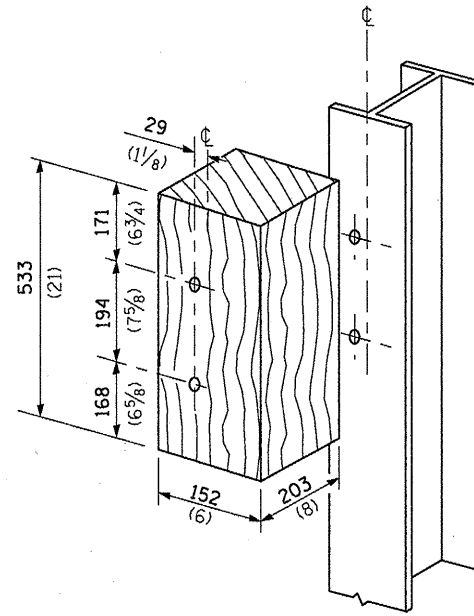

POSTS 1-11 WOOD BLOCKOUT DETAIL

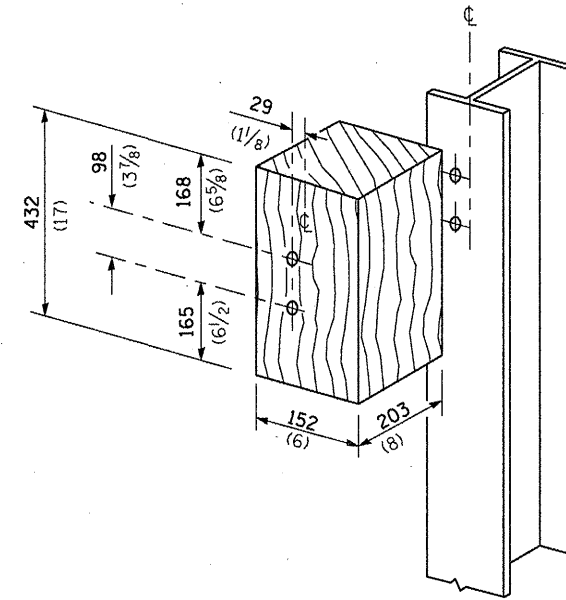

POST 12 WOOD BLOCKOUT DETAIL

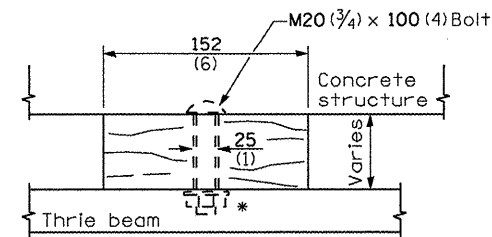

WOOD BLOCKOUT D

Bolt to thrie beam with M20 (3/4) by 100 (4) bolt, washer & nut. Reverse direction of insertion. \*

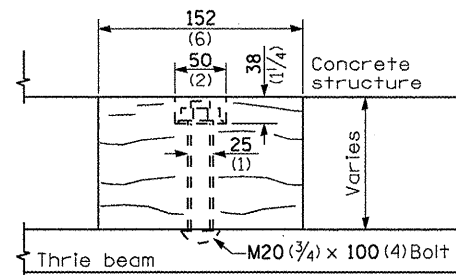

WOOD BLOCKOUT C

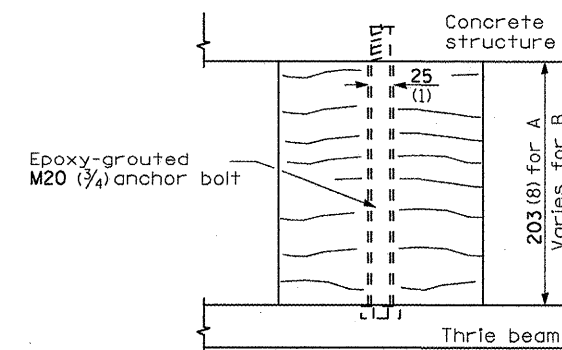

WOOD BLOCKOUT A & B

FILE NAME =	USER NAME = schwankerg	DESIGNED -	REVISED -
c:\pwwork\pwwid\schwankerg\0184951\366A25-shd-details.dgn		DRAWN -	REVISED -
PLOT SCALE = 100.0000 "/ IN.		CHECKED -	REVISED -
PLOT DATE = Feb 17, 2010 - 03:54:00 PM		DATE -	REVISED -

STATE OF ILLINOIS  
DEPARTMENT OF TRANSPORTATION

PRE-MGS EFFECTIVE 4-1-06  
TRAFFIC BARRIER TERMINAL, TYPE 6B  
STANDARD 631033-01

F.A. RTE.	SECTION	COUNTY	TOTAL SHEETS	SHEET NO.
VAR.	*	VAR.	36	33
FED. ROAD DIST. NO. ILLINOIS FED. AID PROJECT			CONTRACT NO. 66A25	

• D-3 HIGHWAY DAMAGE REPAIR 2010

SCALE: SHEET NO. OF SHEETS STA. TO STA. Sheet 2 of 2