

STA. 52+40.00 - 52+55.00

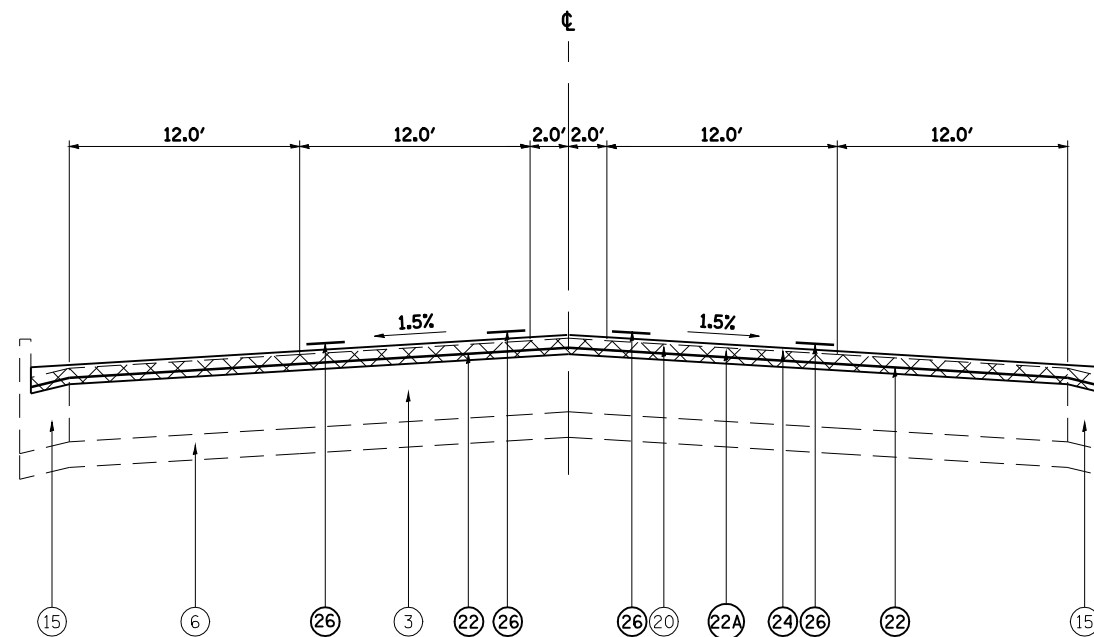

STA. 52+55.00 - 78+45.12

LEGEND

- ① EXISTING CONCRETE BASE COURSE FOR BRICK FOUNDATION, DEPTH UNKNOWN
- ② EXISTING PCC BASE COURSE (9")
- ③ EXISTING PCC BASE COURSE (10")
- ④ EXISTING CONCRETE BASE COURSE FOR TROLLEY CAR RAIL BED, DEPTH UNKNON
- ⑤ EXISTING STABILIZED SUB-BASE (4")
- ⑥ EXISTING SUB-BASE GRANULAR MATERIAL (4")
- ⑦ EXISTING SUB-BASE GRANULAR MATERIAL, TY A (12")
- ⑧ EXISTING LEVELING BINDER (MACHINE METHOD), (1")
- ⑨ EXISTING BRICK PAVEMENT
- ⑩ EXISTING PCC PAVEMENT (10")
- ⑪ EXISTING HOT-MIX ASPHALT BASE OR P.C.C. PAVEMENT*
- ⑫ EXISTING HOT-MIX ASPHALT CONCRETE SURFACE
- ⑬ EXISTING HOT-MIX ASPHALT CONCRETE PAVEMENT (FULL DEPTH). TYPE 1, 1 1/2" (11 1/2" BINDER MIXTURE B, TYPE 1; 2" SURFACE, MIXTURE D, CLASS I, TYPE 1
- ⑭ EXISTING TOP SOIL (4")
- ⑮ EXISTING COMBINATION CONCRETE CURB & GUTTER, TY B-6.24
- ⑯ EXISTING COMBINATION CONCRETE CURB & GUTTER, TY B-15.60
- ⑰ EXISTING CONCRETE MEDIAN, TY C4
- ⑱ EXISTING CONCRETE MEDIAN (4")
- ⑲ EXISTING CORRUGATED CONCRETE MEDIAN
- ⑳ EXISTING HOT-MIX ASPHALT CONCRETE SURFACE COURSE, (1 1/2")
- ㉑ EXISTING AREA REFLECTIVE CRACK CONTROL TREATMENT
- ㉒ PROPOSED LEVELING BINDER (1")
- ㉒A PROPOSED HOT-MIX ASPHALT SURFACE REMOVAL (2 1/2")
- ㉓ PROPOSED HOT-MIX ASPHALT SURFACE REMOVAL (2")
- ㉔ PROPOSED HOT-MIX ASPHALT SURFACE COURSE, MIX D, N70 (1 1/2")
- ㉕ PROPOSED POLYMER HOT-MIX ASPHALT SURFACE COURSE, MIX D, N70 (2")
- ㉖ PROPOSED PAVEMENT MARKING, LINE (5")

STATION EQUATION:
STA. 78+45.12 (BK) = 1+56.70 (AH)

FILE NAME =	USER NAME = laughlinr1	DESIGNED -	REVISED -	STATE OF ILLINOIS DEPARTMENT OF TRANSPORTATION	TYPICAL SECTIONS SECTION "C" (I 55 - PEORIA RD)	F.A.P. RTE. 658	SECTION	COUNTY SANGAMON	TOTAL SHEETS 206	SHEET NO. 58		
et:\pwork\PWIDOT\LAUGHLINRL\dms47710\0672C35-shr-typicals-155_PeoriaRd.dgn	DRAWN -	REVISED -	REVISED -			SCALE:	SHEET NO. 1 OF 3 SHEETS	STA.	TO STA.	ILLINOIS FED. AID PROJECT		
PLOT SCALE = 10.0000 "/ IN.	CHECKED -	REVISED -	REVISED -			CONTRACT NO. 72C35						
PLOT DATE = Apr-30-2010 11:23:34AM	DATE -	REVISED -	REVISED -			* 1-1(RS,TS-1027RS-6)79Z&102RS-4						