

SHOULDER DETAIL

STA. 5+28 TO STA. 20+42

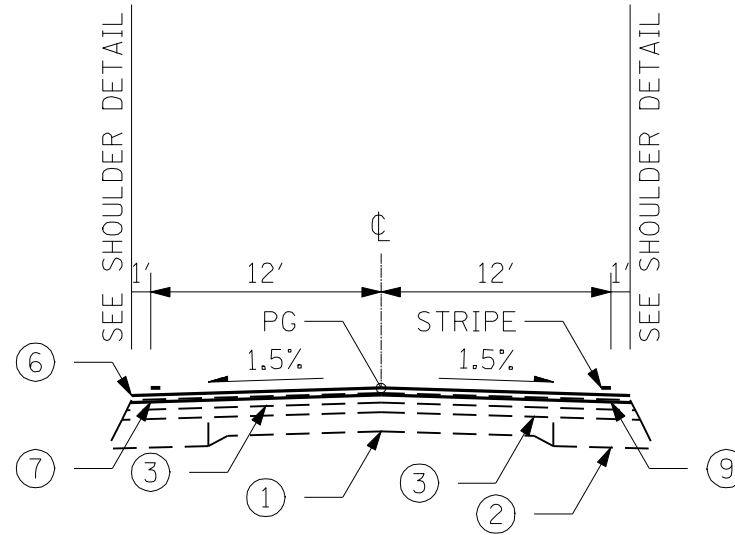

TYPICAL SECTION

STA. 5+28 TO STA. 18+09

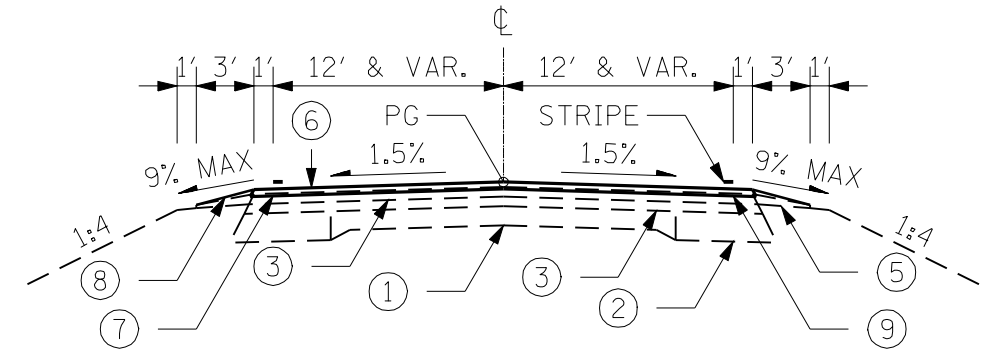

TYPICAL SECTION

STA. 31+00 TO STA. 96+05

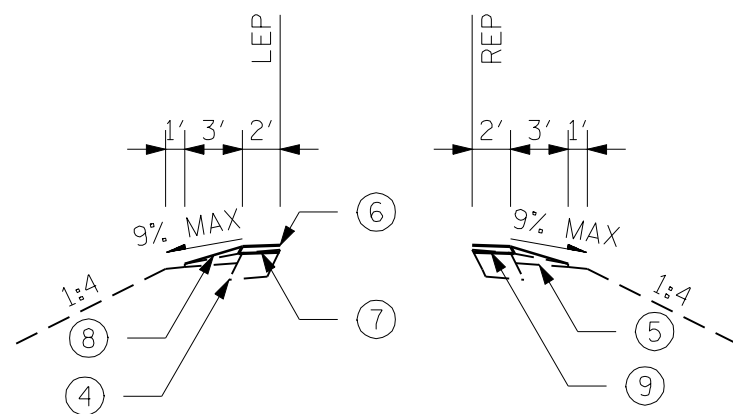

SHOULDER DETAIL

STA. 20+42 TO STA. 31+00

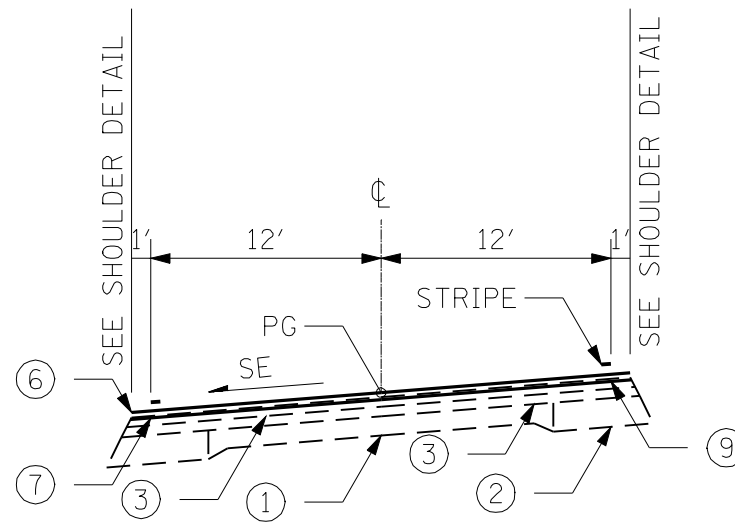

TYPICAL SECTION

STA. 18+09 TO STA. 31+00

- ① EXIST. PCC PAVEMENT 9'-6"-9"
- ② EXIST. HMA BASE COURSE WIDENING (8" TO 9")
- ③ EXIST. HMA RESURFACING (3" TO 6 1/2")
- ④ EXIST. HMA SHOULDER 8"
- ⑤ EXIST. AGG. SHOULDER
- ⑥ PROP. HMA SURFACE COURSE, MIX "C" OR MIX "D", N50 OR N70 (1 1/2")
- ⑦ PROP. LEVELING BINDER (MACHINE METHOD), N50 OR N70 (3/4")
- ⑧ PROP. AGG. SHOULDERS, TYPE B
- ⑨ PROP. HMA SURFACE REMOVAL, VARIABLE DEPTH

FILE NAME =	USER NAME = laughlinr1	DESIGNED -	REVISED -	STATE OF ILLINOIS DEPARTMENT OF TRANSPORTATION	TYPICAL SECTIONS (ILLINOIS 99)			F.A.S. RTE.	SECTION	COUNTY	TOTAL SHEETS	SHEET NO.
er:\pwork\pwidot\LAUGHLINRL\0200040\672C37-shr-typical.dgn	PLOT SCALE = 10,000' / IN.	DRAWN -	REVISED -					2585	121(RS-5)	BROWN	49	6
	PLOT DATE = Apr-08-2010 03:17:53PM	CHECKED -	REVISED -		CONTRACT NO. 72C37							
		DATE -	REVISED -		SCALE:	SHEET NO.	OF SHEETS	STA.	TO STA.	FED. ROAD DIST. NO.	ILLINOIS FED. AID PROJECT	