

N. Appr. shown, S. Appr. similar

\*Tilt #9 b4(E) bars as required to maintain clearance.  
 \*\*Space between a7(E) bars, typ. each parapet.

Notes:  
 See sheet 21 of 36 for Sections C-C & D-D and View E-E.  
 a7(E) thru a10(E), w(E) and w1(E) bar spacings measured perpendicular to  $\text{\textcircled{C}}$  Rdwy.  
 Bars indicated thus 24 x 2-#4 indicates 24 lines of bars with 2 lengths per line.

\*\*\* Cost included with Concrete Superstructure.

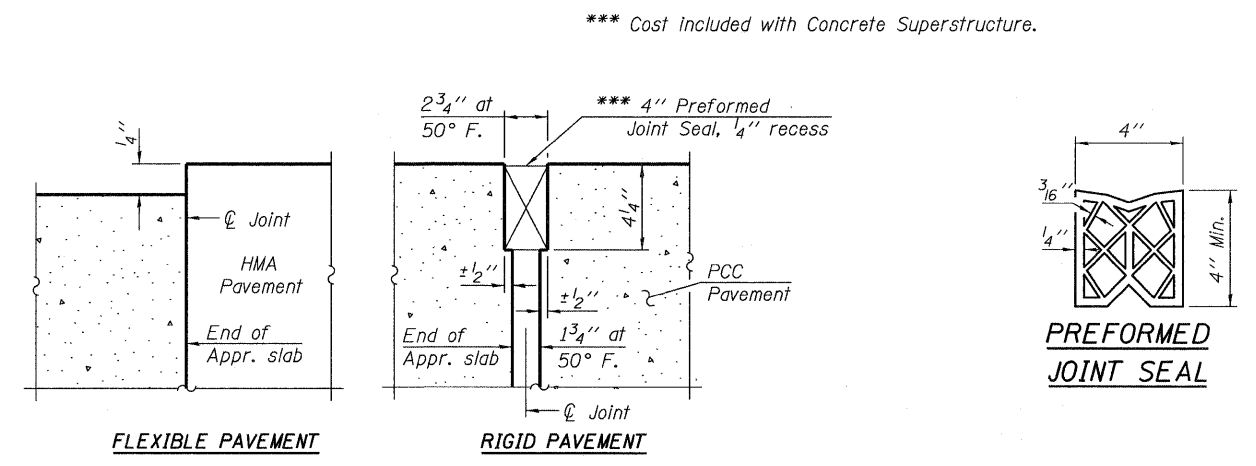

**MINIMUM BAR LAP**

#4 bar = 1'-4"  
 #5 bar = 1'-8"

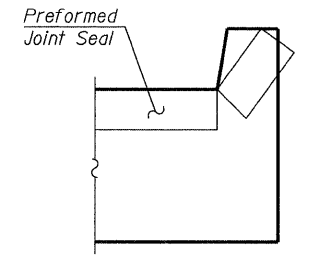

**VIEW F-F**

Angle Preformed Joint Seal at 45° at curbs when req'd for drainage.

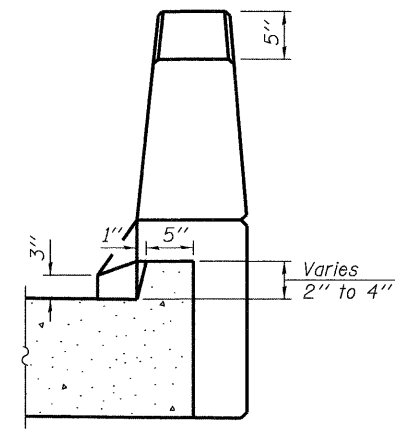

**VIEW B-B**

**BRIDGE APPROACH SLAB DETAILS**  
**STRUCTURE NO. 058-0136**

<b>Coombe-Bloxdorf P.C.</b> - CIVIL ENGINEERS - - STRUCTURAL ENGINEERS - - LAND SURVEYORS - Design Firm License No. 184-002703	PROJECT NO. 08052-6 SCALE DATE 1/17/10 DESIGN BY BD/MCB DRAWN BY TFG CHECKED BY MCB	SHEET NO. 20 36 SHEETS	F.A.P. RTE. 322 SECTION (58-64HB-1)B-1 COUNTY MACON TOTAL SHEETS 149 SHEET NO. 79	CONTRACT NO. 74387 FED. ROAD DIST. NO. 7 ILLINOIS FED. AID PROJECT
--	--	---------------------------	---	---