

**PROPOSED RAMP E**  
 STA 10+91.65 TO STA 11+34.38  
 GRADING MAY VARY, SEE INFIELD GRADING PLANS FOR DETAILS

- \* (B) LT FROM STA 10+91.65 TO STA 13+00 AND (DEPRESSED FROM STA 11+15.00 TO STA 13+00)
- (B) RT FROM STA 11+06.78 TO STA 15+33.96 (DEPRESSED)
- \*\* BEGIN (5A) (LT) AT 11+40.07, 17' LT

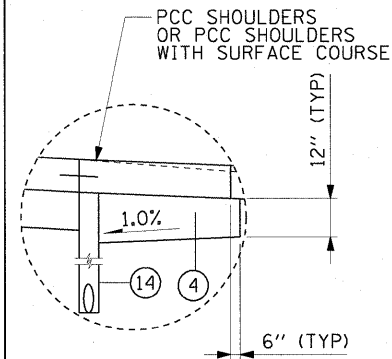

**DETAIL 1**

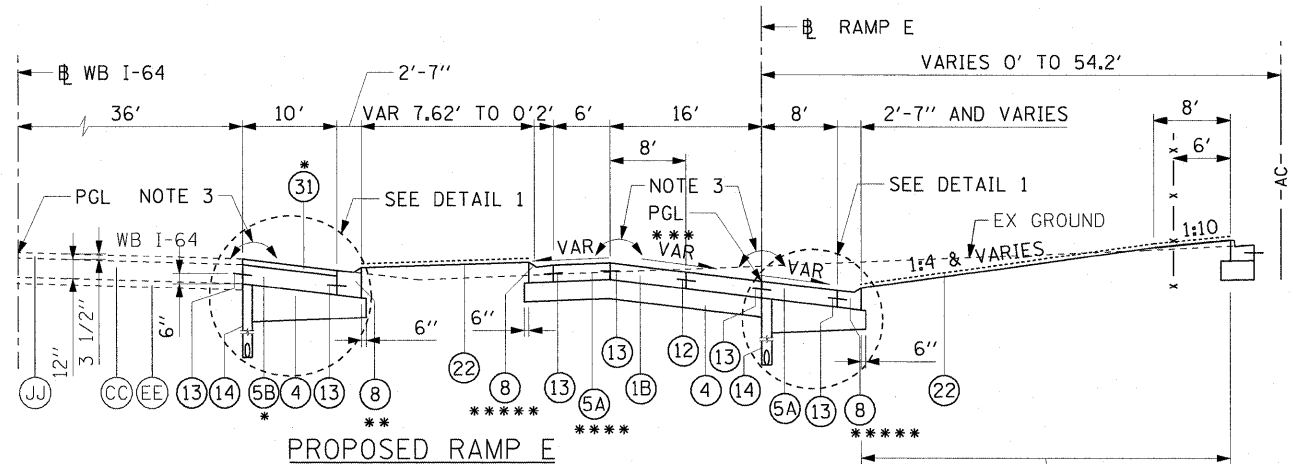

**PROPOSED RAMP E**  
 STA 11+34.38 TO STA 15+38.49  
 GRADING MAY VARY, SEE INFIELD GRADING PLANS FOR DETAILS

- \* BEGIN (31) & (5B) AT STA 87+42.34 WB I-64 = STA 11+34.74 RAMP E
- \*\* COMBINATION CONCRETE CURB AND GUTTER, TYPE B-6.24 (DEPRESSED) BEGINS FROM STA 86+42.47 TO STA 90+57.05 (WB I-64) SEE SE TRANSITION DATA TABLE FOR SUPERELEVATION TRANSITIONS
- \*\*\* (5A) BEGINS AT STA 11+40.07 AND VARIES FROM 1' TO 6' FROM STA 11+40.07 TO STA 12+04.89
- \*\*\*\*\* (B) DEPRESSED LT FROM STA 11+34.38 TO STA 13+00 AND (6B) LT FROM STA 13+00 TO STA 15+38.49
- (B) DEPRESSED RT FROM STA 11+34.38 TO STA 15+33.96 AND (6B) FROM STA 15+33.96 TO STA 15+38.49

**EXISTING LEGEND:**

- (A) PCC PAVEMENT - 10"
- (B) BITUMINOUS CONCRETE SURFACE COURSE, CLASS I - 3/4"
- (C) SUB-BASE GRANULAR MATERIAL, TYPE A - 4"
- (D) SUB-BASE GRANULAR MATERIAL, TYPE A - 6"
- (E) BITUMINOUS MATERIALS (PRIME COAT)
- (F) AGGREGATE (PRIME COAT)
- (G) LEVELING BINDER (MACHINE METHOD)
- (H) BITUMINOUS CONCRETE BINDER COURSE - 2 1/4"
- (I) BITUMINOUS CONCRETE SURFACE COURSE, CLASS I - 1 1/2"
- (J) PORTLAND CEMENT CONCRETE BASE COURSE - 8"
- (K) PORTLAND CEMENT CONCRETE SIDEWALK - 4"
- (L) PORTLAND CEMENT CONCRETE SIDEWALK - 4"
- (M) COMBINATION CURB AND GUTTER TYPE B-6.12
- (N) COMBINATION CURB AND GUTTER TYPE B-6.12 (SPECIAL)
- (O) COMBINATION CURB AND GUTTER TYPE B-6.24
- (P) PCC PAVEMENT - 10" AND VARIES
- (Q) CONCRETE CURB, TYPE B - 6" HIGH
- (R) TYPE B CURB (MODIFIED)
- (S) PCC MEDIAN SURFACE - 4"
- (T) CONCRETE MEDIAN SURFACE - 4"
- (U) PORTLAND CEMENT CONCRETE BASE COURSE - 9"
- (V) CONCRETE GUTTER
- (W) FENCE
- (X) LONGITUDINAL METAL JOINT
- (Y) EXISTING CURB
- (Z) CONCRETE RETAINING WALL
- (AA) BITUMINOUS CONCRETE BINDER COURSE - 1 1/2"
- (AB) STABILIZED SHOULDER
- (AC) AGGREGATE BASE COURSE, TYPE A - 4"
- (AD) CONTINUOUSLY REINFORCED PORTLAND CEMENT CONCRETE PAVEMENT (CRPCCP) - VARIES FROM 12" TO 13 1/4"
- (AE) PIPE UNDERDRAINS - 6"
- (AF) STABILIZED SUB-BASE - 4"
- (AG) AGGREGATE SHOULDER TYPE A
- (AH) INCIDENTAL BITUMINOUS SURFACING
- (AI) CONCRETE GUTTER (MODIFIED)
- (AJ) HMA SURFACE COURSE, MIX "C", N70 - 2"
- (AK) HMA OVERLAY

**PROPOSED LEGEND:**

- (1) PORTLAND CEMENT CONCRETE PAVEMENT
  - (1A) - 10" (JOINTED) (LOCAL ROADS)
  - (1B) - 10 1/2" (JOINTED) (RAMPS)
- (2) HOT-MIX ASPHALT OVERLAY - 2 1/4"
  - (2a) HOT-MIX ASPHALT SURFACE COURSE, MIX "D" N70 - 1 1/2"
  - (2b) LEVELING BINDER, (MACHINE METHOD), N70 - 3/4"
- (3) PORTLAND CEMENT CONCRETE BASE COURSE - 10"
- (4) AGGREGATE BASE COURSE, TYPE A, 12"
- (5) PORTLAND CEMENT CONCRETE SHOULDERS
  - (5A) - 10 1/2" (FOR 10 1/2" PCC JT)
  - (5B) - 12" (WB & EB I-64 TIE-IN)
  - (5C) - 15 1/2" (WB I-64 GOSES)
  - (5D) - 18" (EB I-64 GOSES)
- (6) AGGREGATE SHOULDERS, TYPE B
  - (6A) - 10" (FOR 10" PCC JT)
  - (6B) - 10 1/2" (FOR 10 1/2" PCC JT)
  - (6C) - 11 1/4" (FOR TEMPORARY PAVEMENT INTERSTATE)
  - (6D) - 15 1/2" (FOR HMA SC "D" N70 - 3 1/2" AND PCC SHOULDERS 12")
  - (6E) - 18" (FOR HMA SC "D" N70 - 6" AND PCC SHOULDERS 12")
- (7) PORTLAND CEMENT CONCRETE SIDEWALK - 4"
- (8) COMBINATION CONCRETE CURB AND GUTTER, TYPE B-6.24
- (9) POROUS GRANULAR EMBANKMENT, SPECIAL
- (10) COMBINATION CONCRETE CURB AND GUTTER, TYPE M-6.06
- (11) CONCRETE MEDIAN, TYPE SM-6.12
- (12) \*6 TIE BARS, 30" LONG AT 30" C-C (IF LONGITUDINAL SAWED JOINT) / \*6 TIE BARS, 24" LONG AT 24" C-C (IF LONGITUDINAL CONSTRUCTION JOINT) (INCLUDED IN PRICE FOR BID FOR VARIOUS PCC ITEMS)
- (13) \*6 TIE BARS, 24" LONG AT 24" C-C (INCLUDED IN PRICE FOR BID FOR VARIOUS PCC ITEMS)
- (14) PIPE UNDERDRAINS - 4"
- (15) CONTINUOUSLY REINFORCED PORTLAND CEMENT CONCRETE PAVEMENT - 12"
- (16) CONCRETE BARRIER SINGLE FACE, 42 INCH HEIGHT
- (17) AGGREGATE BASE COURSE, TYPE A, THICKNESS AS SPECIFIED ON SECTION
- (18) CONCRETE GUTTER TYPE A
- (19) CONCRETE MEDIAN SURFACE - 4"
- (20) STEEL PLATE BEAM GUARDRAIL, TYPE A, 6' POSTS OR TRAF BAR TERM
- (21) CHAIN LINK FENCE - 6'
- (22) SEEDING AND MULCHING (SEE SEEDING AND MULCHING SCHEDULE)
- (23) CONCRETE BARRIER SINGLE FACE, 42 INCH HEIGHT (SPECIAL)
- (24) CONCRETE CURB AND GUTTER OUTLET SPECIAL
- (25) HOT-MIX ASPHALT SURFACE REMOVAL - 2 1/4"
- (26) TEMPORARY PAVEMENT (INTERSTATE) - 11 1/4"
  - (26a) HOT-MIX ASPHALT SURFACE COURSE, MIX "D", N70 (IL 9.5 mm) - 1 3/4"
  - (26b) HOT-MIX ASPHALT BINDER COURSE, IL-19.0, N70 - 9/2"
- (27) POLYMERIZED HOT-MIX ASPHALT SURFACE COURSE, MIX "F", N90 - 3 1/2"
- (28) BITUMINOUS MATERIALS (PRIME COAT)
- (29) AGGREGATE (PRIME COAT)
- (30) HOT-MIX ASPHALT SURFACE REMOVAL - VARIABLE DEPTH
- (31) HOT-MIX ASPHALT SURFACE COURSE, MIX "D", N70 - 3 1/2"
- (32) HOT-MIX ASPHALT SURFACE COURSE, MIX "D", N70 - 6"

**NOTES:**

1. DUE TO THE SKEWED NATURE OF THE ROADWAYS IN THIS PROJECT, THE FOLLOWINGS ARE THE COMPASS DESIGNATIONS TO THE ROADWAYS:  
 15TH STREET (NORTH-SOUTH), BAUGH AVENUE (EAST-WEST), ST. CLAIR AVENUE (EAST-WEST), WB I-64 (WEST)
2. SEE HOT-MIX ASPHALT MIXTURE REQUIREMENTS ON TYPICAL SECTIONS SHEET 3 OF 14.
3. WHEN THE SUPERELEVATION RATE OF THE PAVEMENT IS BETWEEN 0% AND 4% THE SHOULDER SHALL BE SLOPED AT 4%. WHEN THE SUPERELEVATION RATE OF THE PAVEMENT EXCEEDS 4% THE SHOULDER SHALL BE SLOPED SO THAT THE ALGEBRAIC DIFFERENCE BETWEEN PAVEMENT AND SHOULDER SLOPES WILL NOT BE GREATER THAN 8%.

FILE NAME =	USER NAME = plm309no	DESIGNED OP	REVISED -
#FILES#		DRAWN OP	REVISED -
	PLOT SCALE = 10.000 ' / IN.	CHECKED DBM	REVISED -
	PLOT DATE = 3/18/2010	DATE 03/19/10	REVISED -

**STATE OF ILLINOIS  
 DEPARTMENT OF TRANSPORTATION**

**TYPICAL SECTIONS**

SCALE: NONE SHEET NO. 12 OF 14 SHEETS STA. TO STA.

F.A.I. RTE.	SECTION	COUNTY	TOTAL SHEETS	SHEET NO.
64	82-1-2HB	ST. CLAIR	345	26
FED. ROAD DIST. NO. ILLINOIS FED. AID PROJECT			CONTRACT NO. 76C49	