

PROPOSED TYPICAL SECTION
 STA. 273+31 TO STA. 282+33
 OMISSION STA. 282+33 TO 299+23

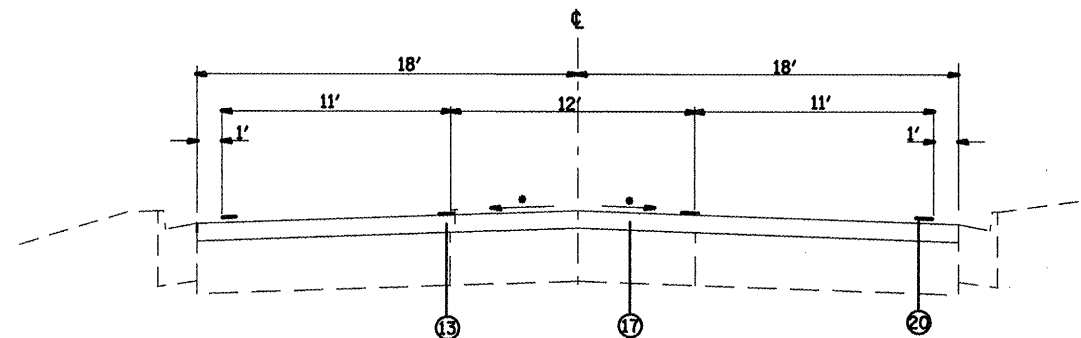

PROPOSED TYPICAL SECTION
 STA. 299+23 TO STA. 311+87

LEGEND

- ① EXISTING PCC PAVEMENT 7"6"7"
- ② EXISTING PAVEMENT, UNKNOWN
- ③ EXISTING HMA BASE COURSE, 9' 1/4"
- ④ EXISTING PCC BASE COURSE WIDENING, 7"
- ⑤ EXISTING HMA BASE COURSE WIDENING, 8"
- ⑥ EXISTING HMA BASE COURSE WIDENING, 9"
- ⑦ EXISTING HMA BASE COURSE WIDENING, 10"
- ⑧ EXISTING HMA RESURFACING
- ⑨ EXISTING HMA SHOULDER
- ⑩ EXISTING AGGREGATE SHOULDER
- ⑪ EXISTING TYPE A GUTTER
- ⑫ EXISTING CCC&G, TYPE B-6.24
- ⑬ PROPOSED HMA SURFACE REMOVAL, 1 1/2"
- ⑭ PROPOSED HMA SURFACE REMOVAL, 1 3/4"
- ⑮ PROPOSED STRIP REFLECTIVE CRACK CONTROL
- ⑯ PROPOSED LEVEL BINDER (MM) N90, 3/4"
- ⑰ PROPOSED HMA SURFACE COURSE MIX "D", N90, 1 1/2"
- ⑱ PROPOSED HMA SHOULDERS
- ⑲ PROPOSED AGGREGATE SHOULDERS, TYPE B
- ⑳ PROPOSED PAVEMENT MARKING

(*) SEE PROPOSED PAVEMENT CROSS SECTION SLOPE SCHEDULE

FILE NAME =	USER NAME = washingtonaq	DESIGNED -	REVISED -
es:\pw\work\p\dot\washingtonaq\d0175198	876d84-sh1-plan.dgn	DRAWN -	REVISED -
	PLOT SCALE = 100.0000' / IN.	CHECKED -	REVISED -
	PLOT DATE = 3/17/2010	DATE -	REVISED -

**STATE OF ILLINOIS
 DEPARTMENT OF TRANSPORTATION**

TYPICAL SECTIONS	
SCALE: _____	SHEET NO. ___ OF ___ SHEETS
STA. 273+31 TO STA. 311+87	

F.A. RTE.	SECTION	COUNTY	TOTAL SHEETS	SHEET NO.
9266	33RS-5	ST. CLAIR	42	13
CONTRACT NO. 76064				
FED. ROAD DIST. NO. ILLINOIS FED. AID PROJECT				