

EXISTING TYPICAL SECTION
(25TH STREET)

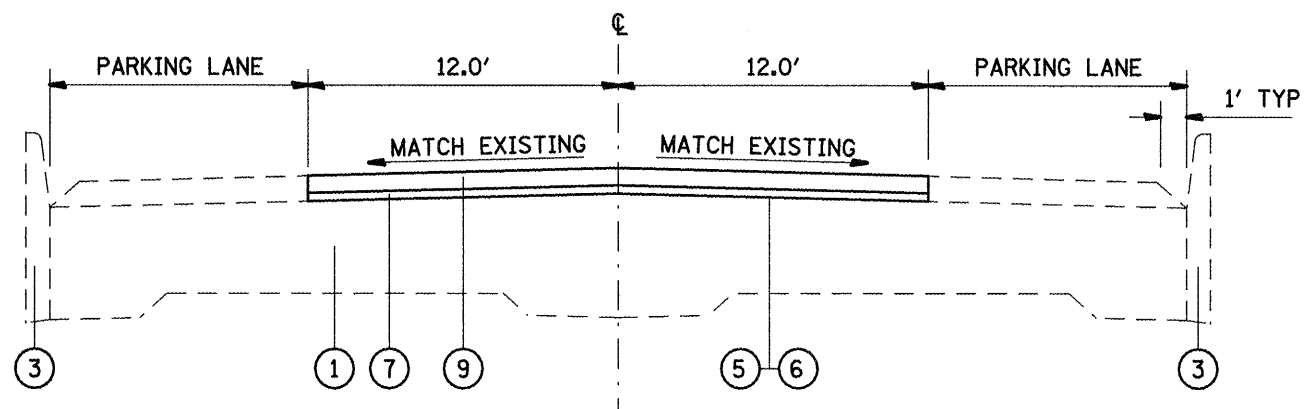

PROPOSED TYPICAL SECTION
(25TH STREET)

STA. 200+00 to STA. 226+45

LEGEND

- ① EXISTING CONCRETE PAVEMENT
- ② EXISTING HMA OVERLAY
- ③ EXISTING CONCRETE CURB AND GUTTER
- ④ PROPOSED HMA SURFACE REMOVAL - 2"
- ⑤ PROPOSED BITUMINOUS MATERIALS (PRIME COAT)
- ⑥ PROPOSED AGGREGATE (PRIME COAT)
- ⑦ PROPOSED LEVELING BINDER (MM), N70 - 3/4"
- ⑧ PROPOSED LEVELING BINDER (MM), N70 - 1"
- ⑨ PROPOSED HMA SURFACE COURSE, MIX D, N70 - 1/2"

NOT TO SCALE

FILE NAME =
c:\pwwork\VPWIDOT\WATERSLE\d0174384\d8

USER NAME = watersle
6d75-ahp-plan.dgn
PLOT SCALE = 100.0000' / IN.
PLOT DATE = 3/17/2010

DESIGNED -
DRAWN -
CHECKED -
DATE -

REVISED -
REVISED -
REVISED -
REVISED -

**STATE OF ILLINOIS
DEPARTMENT OF TRANSPORTATION**

TYPICAL SECTIONS (LOCATION #2 - 25TH STREET)
SCALE: SHEET NO. 1 OF 1 SHEETS STA. TO STA.

| | | | | |
|---|------------------------------|---------------------|--------------------|----------------|
| F.A. SITE 9228- -9189 | SECTION (Z-1)RS-2, 29RS-6 | COUNTY ST. CLAIR | TOTAL SHEETS 33 | SHEET NO. 5 |
| FED. ROAD DIST. NO. 8 ILLINOIS FED. AID PROJECT | | | CONTRACT NO. 76D75 | |